

Safety Information

>All electrical work must be undertaken by a qualified contractor to ensure compliance with latest edition BS 7671 and IEE/IET wiring regulations.

> Before installing an LED IP20 Emergency Twin Spot or doing any maintenance, ensure power supply is turned off at the circuit breaker or fuse box.

> This product is designed for permanent connection to fixed wiring; the circuit should be protected with the appropriate MCB or fuse.

Environment

> Please DO NOT dispose of electrical items or packaging as unsorted waste. Use the recycling facilities provided by your local authorities.

PRODUCT DIMENSIONS

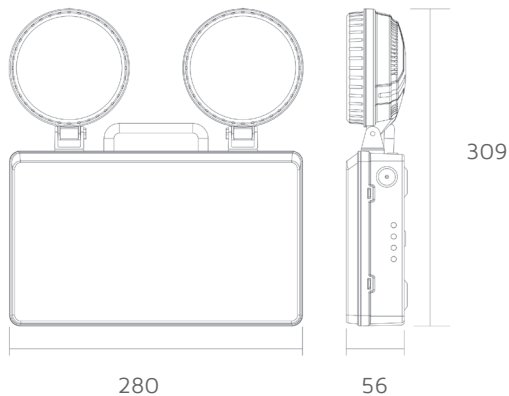

All units are in mm

Important Warranty Information

The LED IP20 Emergency Twin Spot has a 3 year warranty. To claim you must provide the product part number and date of manufacture, which can be found on the label attached to the luminaire housing along with the original purchase invoice. Battery warranty is 1 year only.



theLIA
MEMBER



NET LED Ltd.
Buckway Business Park
300 Anderson Road
Cambridge
CB24 4UQ
sales@netled.co.uk
www.netled.co.uk

Technical Helpline: 01223 851505
Email: support@netled.co.uk

Drawing No: NET-44-10-70_V1
www.netled.co.uk/downloads

Distributed by

NET LED
LIGHTING

LED IP20
EMERGENCY
TWIN SPOT

LED IP20 EM TWIN SPOT NET-44-10-68

KEY DATA

Light Source:	LED
Size (mm)	280 x 308.5 x 55.5mm
Power	5.2W
Luminous Flux	2 x 193lm
Colour Temperature	6500K
Housing Material	Polycarbonate
IP Rating	IP20
Manufacturer	DPPUL



SUPPLY/EARTH CLASS

