

Vent-Axia

The UK's Leading Ventilation Company

Product Selector

12th Edition

www.vent-axia.com

Ventilation Solutions

At Vent-Axia, we pride ourselves on being able to provide you, our customer, with the best products, services and tools. We are able to supply everything you need for any ventilation job. In this brochure, you will find the widest selection available on the market for your ventilation installation, as well as a selection of other products such as heating, cooling and hand dryers.



As market leaders we are continually updating and improving our product range to ensure we can offer you the widest range available. The next 12 months promise to be an exciting time at Vent-Axia, with a number of best in class products launched in recent months. See page 80 for details of our Lo-Carbon Sentinel Kinetic[®] Advance; the first of our new generation of MVHR systems incorporating a range of unique features. Offering units with wifi and App control options along with integrated digital controls for easy installation the range is designed with developers, specifiers and installers in mind. Another App controlled fan is our new Svava, a constant running bathroom or kitchen fan which can be set up and controlled from your phone and offers features such as Silent Mode and Purge. We have also launched the Sentinel Kinetic 200ZP, an addition to our best in class MVHR range, designed specifically for installation in restricted spaces such as apartments and boasts an impressive 86% thermal efficiency. And finally, the new Lo-Carbon Revive can be found on page 20, the fan designed especially for the Social Housing market with Multi-Vortex[™] and Smart Sense[™] technology. Designed with the landlord, contractor and resident in mind, there is nothing else like it available today.

As well as the investment in our products, we also invest in our people. Vent-Axia has the largest sales force of any ventilation manufacturer in the UK. This enables us to talk to our customers face to face, meaning we can provide a personalised specification and support service and can listen to our customers' feedback and react quickly to their changing needs.

Did you know that Vent-Axia has a range of tools available on our website that can help you select the products you need, such as our on-line product selector? You can also sit online CPDs and book training courses; all helping to ensure the right product for the right job is installed correctly and working first time. We have an online trade counter, frequently asked questions as well as up-to-date product availability and technical literature all at the click of a button. Visit the website today to find out more; www.vent-axia.com. We feel this really strengthens our position as a supplier of ventilation and heating, whatever your application or need.

I would like to take this opportunity to thank you for your valued business, should you have any specific questions please do not hesitate to contact your local Vent-Axia Sales Executive.

Kind Regards

Mark Hoskins
Managing Director

Employing over 800 people across 4 manufacturing sites, we continue to invest in UK manufacturing.

Being in control of manufacture of the component parts including motors and mouldings all within the UK, we reduce our lead times as well as our carbon footprint.

Vent-Axia Group Ltd

Crawley - Unitary plastic fan manufacture

- Our largest total manufacturing and office space with over 230,000 sq. ft. housing the Vent-Axia Head Office as well as the Group Head Office.
- Manufacturing and warehouse space totals 108,000 sq. ft.
- Manufacture of plastic ventilation ranges
- Design and test facilities for rigorous product testing including safety, airflow and climate chambers - BEAB approved
- Head Office functions including Sales Office, Customer Services, Technical Support and Marketing

Reading - Plastic Moulding and extrusion manufacture

- 50,000 sq ft injection and extrusion factory running 24 hours a day
- Over 30 injection moulding machines
- 5 extrusion lines for rigid and flexible duct

Dudley - Systems and Industrial manufacture

- Our largest site with 120,000 sq footage of manufacturing and warehousing space
- Manufacturing base for our metal products including Sentinel Demand Ventilation and Sentinel Totus
- Also the home of our heat recovery (MVHR) and Multivent (MEV) products



Technical Advice

Free technical, installation and sales advice is available from the Vent-Axia Technical Support Centre.

Distribution

Vent-Axia products are available from all leading industrial fan stockists. For further information, or in case of difficulty, please contact the Vent-Axia Sales Centre in Crawley.

Sound Levels

Vent-Axia has a state of the art sound testing facility at Crawley (UK) providing sound power levels for comparison purposes tested in accordance with ISO 13347-1:2004 and ISO 13347-2:2004. This is an international standard that describes methods for determining sound power levels of fans in one-third octave bandwidths to allow comparisons to be made between different products from different manufacturers in a fair and consistent manner.

The data is not intended to equal the sound power levels experienced in any specific installation but enable the customer to compare different products and make an informed decision on their requirements.

Each installation will use different building materials that can have an effect on how sound is absorbed and/or reflected. It is therefore very difficult to predict the exact sound power levels exhibited in any given installation.

Performance

Tested in Vent-Axia test laboratories, performance testing is carried out in a balanced chamber test duct to BS 848: Part 1. This has a booster fan to overcome the system resistance.

The volume flow is measured by a pressure drop across a calibrated orifice plate at the entry to the system.

An adjustable damper provides a variable resistance to the test fan enabling its performance characteristics to be measured. The rated figures given are at free air performance.

BSEN ISO 9001/14001

Vent-Axia limited is certified by the British Standards Institution to BS EN ISO 9001 Cert. No. FM1792 QAS No. 3284/37, and BSEN ISO 14001 Cert. No. EMS600403.

Intellectual Property

Products shown in this catalogue include aspects which are protected under patent, copyright, design copyright, registered design and trademark laws. Vent-Axia will take all necessary legal action in any part of the world against any party found to be manufacturing, distributing, selling or otherwise dealing with any article which infringes the Company's rights in its products.

Guarantee

Applicable to units installed and used in the United Kingdom.

For details of guarantee outside the United Kingdom, contact your local supplier.

Please visit our website www.vent-axia.com/help/guarantees for details of guarantee periods.

In the event of any part being found to be defective, the appliance will be repaired, or at the Company's option, replaced, without charge, provided that:

1. The product has been installed and used in accordance with the instructions given with each unit;
2. The product has not been connected to an unsuitable electrical supply (the correct electricity supply voltage is shown on the appliance rating label attached to the unit);
3. The product has not been subjected to misuse, neglect or damage;
4. The product has not been modified or repaired by any person not authorised by the Company;
5. The application is within the specification of the unit;
6. The product is connected to Vent-Axia switch gear;
7. Thermal overload protection has been correctly connected;
8. The product has been subject to regular maintenance appropriate to the installation;
9. When returning the product under guarantee, evidence of purchase is provided.

Conditions of sale

All sales by Vent-Axia are made only upon the terms of the Company's Conditions of Sale (www.vent-axia.com/help/conditions-sale), a copy of which may be obtained upon request.

Online Heating & Ventilation Tools

Each tool has been designed with you in mind, making it simple to use & effective to apply, visit www.vent-axia.com/tools-services.

Online Product Selector

Our fully comprehensive online product selector tool. Choose from our complete specification range to best suit your project.

Online CPD

Vent-Axia offers a selection of CPD material online. With the addition of a questionnaire, you can independently complete your chosen module at your own convenience.

Online Trade Counter

Distributors with accounts can log in or register to check our live stock system for prices & stock availability & also review your previous trade orders.

Online Heating Calculators

By using the Vent-Axia Online Sizing Guides, you will be able to determine which product is suitable for you, helping you to achieve thermal comfort all year round.

Online Axial Fan Calculator

An interactive tool to help you calculate the installed performance of an axial fan when its being tested with a vane anemometer.

Energy Related Products Directive (ErP)

As part of the ongoing drive for energy efficiency within Europe, as of January 2016 ventilation devices over 30 Watts now come under the scope of the Energy Related Products Directive. The legislation sets minimum performance criteria across a range of fans and ventilation devices under two sets of legislation; 'residential' ventilation and 'non-residential' ventilation.

As a result of the legislation we have reviewed our products and where required made updates to ensure they comply. The primary changes have meant that a number of products have had alternative motors specified or have been updated to enable speed control. However, we have ensured that the installation methods remain unaffected. Through the review we have also taken the opportunity to rationalise our range where needed. All relevant products in this literature have been updated as required by the ErP legislation. Please note that where a product changes due to ErP, there will be a transitional period as we move from the old to the new model, and any stock you currently hold will not be affected by this regulation and can be sold as normal.

Residential Products

Residential Products has a secondary directive which requires some products to carry an energy label as described below:

Residential Ranges - Small fans

The majority of small residential fans are unaffected by the legislation as any device below 30 Watts is currently out of scope. The information on them is recorded however and can be found at www.vent-axia.com/erp

The Duet and Gemini fans have been delisted, but are still available as spares so please contact sales@vent-axia for more information.

MVHR and MEV products

These products do come into the scope of the legislation and will carry an energy label. There are some minimum energy efficiency requirements as well as the requirement for a summer bypass on heat recovery models. A small number of our products have been updated to ensure they meet these requirements. The following product has been discontinued:

- Kinetic E

Energy Efficiency Class

Products within the scope of ErP now need to carry a rating that shows their Energy Efficiency Class. This information is called a 'SEC Class' and is provided in all product literature and on the energy label.

A product's SEC class is affected by how the product is controlled. This is referred to as Local Demand Control (LDC) and indicates how many 'sensors' a fan should have. The regulations require that single room fans, such as a bathroom fan, should have at least 1 sensor. Units that are ducted, such as an MEV unit, need to have more than one sensor. Examples of these are a pull cord/light switch or humidistat.

In our literature, where appropriate we have shown the rating if an additional LDC was added to a product. In those cases, you will see a table similar to the one below which has a heading (incl LDC). This is so you can choose the most efficient option for your needs.

SEC Rating Example

Model	SEC Class*	SEC Class (incl. LDC)
HR200	C	B

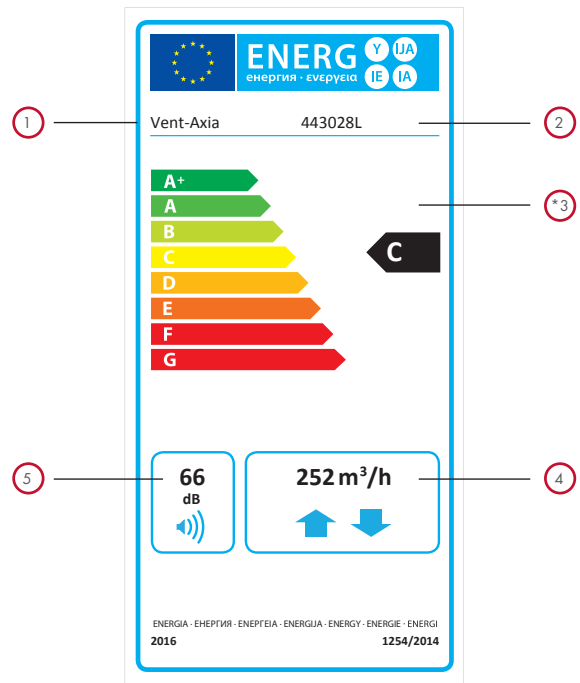

- ① Manufacturers name
- ② Model name
- ③ Energy Efficiency Class
- ④ Max flow rate
- ⑤ Sound Level

Non-Residential Ranges

Non-Residential products have had minimum performance and efficiency levels established, but there is no requirement to introduce energy labels. Some products have been updated with new motors and enabled for speed control.

Non-Residential ranges are split into a number of different categories dependent on their application and function. These can be described as follows:

1. Fans
2. Uni-directional Ventilation Units
3. Bi-directional Ventilation Units

1. Fans

These are products where there is a simple single case that directs air on and off the impellor. Examples include axial plate and case fans. These examples are out of scope of this legislation.

Changes to the way we sell products

The ErP regulations gave us the opportunity to review our product ranges and in some cases has enabled us to improve the way we stock and sell them. Examples of this include T-Series and Standard Range fans. You can now buy these as either the entire product or in modular format. The entire product can be purchased using the existing part number that you have always used. Alternatively, you can purchase just the motor core or just the fitting kit as required.

2. Unidirectional ventilation units

This includes products that are one direction only, and where there is a secondary housing around a fan.

This is the product category which has required the most changes. The impact of the efficiency legislation has meant that it has become virtually impossible to comply using a forward curved AC centrifugal fan. We are therefore moving to backward curved centrifugal fans in all of our AC box fan ranges. This will mean changes to the box sizes and adjustment to performances, the following ranges are particularly affected.



ACQ/ATQ



QP/QPTW

We have a number of product ranges that have been reaching the end of their life cycle and we have taken the opportunity to rationalise these. See our latest Specification Brochure for specific details on our current ranges.

3. Bi-directional ventilation units

These are product ranges that both supply and extract such as heat recovery units.

There are now minimum energy requirements set for heat recovery efficiency. Any product with an efficiency of 67% or lower does not comply. Both the Totus² and ERV-HIBOX ranges are unaffected by these changes, however the low efficiency heat recovery ERV-BOX products will be discontinued. See our Specification Brochure for more details.

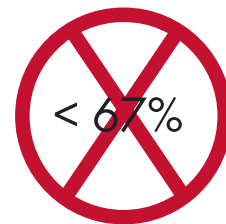

Heat recovery minimum efficiency

Contents

LO-CARBON RESIDENTIAL FAN	8-31	dMEV, MEV & PIV SYSTEMS	66-85
NEW Lo-Carbon Svava Axial Bathroom/Toilet Fan	10-11	Lo-Carbon Centra®/SELV dMEV Unit	68-69
Lo-Carbon iQ Intelligent Axial Bathroom Fan	12-13	Lo-Carbon Response/SELV dMEV Unit	70-71
Lo-Carbon VA100®/SELV Axial Bathroom/Toilet Fan	14-15	Lo-Carbon Multivent MEV Unit	72-73
Lo-Carbon Silhouette® 100/SELV Bathroom/Toilet Fan	16-17	Multivent MEV Unit	74-75
Lo-Carbon Centra®/SELV dMEV Unit	18-19	Lo-Carbon Sentinel® Multivent/Plus	76-79
NEW Lo-Carbon Revive /SELV Bathroom/Kitchen Filterless	20-21	Lo-Carbon Multivent MVDC-MS/MSH MEV Unit	80-81
Lo-Carbon Solo Plus/SELV Centrifugal Bathroom/Toilet Fan	22-23	Lo-Carbon PoziDry Positive Pressure Unit	82-83
Lo-Carbon Minivent Ducted Bath/Shower Fan Kit	24	Lo-Carbon PoziDry Compact Positive Pressure Unit	84-85
Lo-Carbon LED Vent-A-light Ducted Bath/Shower Fan Kit	25		
Lo-Carbon Quadra®/SELV Centrifugal Fan	26-27	SINGLE ROOM dMVHR	86-95
Lo-Carbon Silhouette® 125 Bathroom/Toilet Fan	28	Lo-Carbon Temptra/SELV Single Rm Heat Recovery	88-89
Lo-Carbon VA150 Axial Kitchen & Utility Room Fan	29	Lo-Carbon HR25 Single Rm Heat Recovery	90-91
Lo-Carbon Silhouette® 150 Axial Kitchen Fan	30-31	HR200WK Single Rm Heat Recovery	92-93
		HR300 Single Rm Heat Recovery	94-95
RESIDENTIAL FAN	32-65	MVHR FOR COMMERCIAL & RESIDENTIAL	96-147
VA100/SELV 12 Axial Bathroom/Toilet Fan	34-35	NEW Lo-Carbon Sentinel Kinetic® Advance MVHR Unit	98-99
Silhouette 100/SELV Axial Bathroom/Toilet Fan	36-37	Lo-Carbon Sentinel Kinetic® Range Overview	100-103
Silent Fan Axial Bathroom/Toilet Fan	38	Lo-Carbon Sentinel Kinetic® MVHR Unit	104-107
Silhouette 125 Axial Bathroom/Toilet Fan	39	Lo-Carbon Sentinel Kinetic® FH MVHR Unit	108-111
LuminAir Fan & Light Combination Unit/Ventilation Kit	40-43	Lo-Carbon Sentinel Kinetic® Plus MVHR Unit	112-115
LuminAir Turbo Fan & Light Ventilation Kit	44-45	Lo-Carbon Sentinel Kinetic® High Flow MVHR Unit	116-117
Solo Plus Centrifugal Bathroom/Toilet Fan	46-47	Lo-Carbon Sentinel Kinetic® Cooker Hood MVHR Unit	118-121
Solo Pro/SELV Centrifugal Bathroom/Toilet Fan	48-49	Lo-Carbon Sentinel Kinetic® Horizontal MVHR Unit	122-127
VA140/150 Axial Kitchen Fan	50	Lo-Carbon Kinetic® Plus E MVHR Unit	128-131
VA150 Window Mount Axial Kitchen Fan	51	Integra Ducted MVHR Unit	132-133
Silhouette 150 Axial Kitchen Fan	52-53	NEW Integra Plus EC Ducted MVHR Unit	134-135
Centrif Duo Centrifugal Kitchen & Utility Room Fan	54-55	HR100R/RS Ducted MVHR Unit	136-137
Centrif Duo Plus Centrifugal Kitchen & Utility Room Fan	56-57	HR200V Ducted MVHR Unit	138-139
Freshvent Natural Vent	58-59	HR500 Single Room Heat Recovery Unit	140-141
Cooker Hoods	60	HR500D Ducted MVHR Unit	142-143
Pull-out System Hood	61	HR500EP/IP Passive HR Unit	144-145
Basics Range	62-63	HR500DP Passive HR Unit	146-147
Eclipse Bathroom & Kitchen Axial Fan	64-65		

DUCTING & FITTINGS	148-171	ACCESSORIES & CONTROLLERS	248-267
COMMERCIAL RANGE	172-215	ROOF UNITS INDUSTRIAL	268-325
ACM 100-315 In-Line Mixed Flow Fan	174-177	Energy Recovery Range (ERV)	270-273
Powerflow In-Line Duct Fan	178-179	EuroSeries (ESP) Plate Mounted Axial Fan	274-281
Lo-Carbon T-series Window/Wall/Roof/Panel	180-189	EuroSeries (ESC) Short Case Axial Fan	282-289
Traditional T-series Window/Wall/Roof/Panel/Darkroom/In-line	190-203	EuroSeries (ESR) Fan Assisted Roof Cowl	290-297
Super T-series Powerful Heavy Duty Wall Fan	204-205	New & Improved Quiet Pack (QP) In-Line Centrifugal Duct Fan	298-301
Traditional Standard Window/Roof/Wall/Panel	206-215	New & Improved Quiet Pack (QPTW) In-Line Twin Fan	302-305
HYGIENE	216-221	Slimpack Fan (SLP) In-Line Centrifugal Duct Fan	306-309
Hand Dryers	218-220	Slimpack Fan (SLPT) In-Line Twin Duct Fan	310-313
Insect Killers	221	EuroSeries (SDX) In-Line Centrifugal Duct Fan	314-317
COOLING	222-227	Speed Controllers Single & Three Phase	318-319
Jupiter De-Stratification Unit	224	Starter & Overloads	320
Hi-Line Plus Ceiling Sweep Fan	225	Sonex Circular Sound Attenuators	321
Portable Air Conditioner	226	Pyrocheck (CVT) Intumescent Fire Dampers	322
12" Wall Fan Portable Cooling	227	Unitex Roof Cowl System	323
Box Fan Portable Cooling	227	Unitex Wall Terminal (SA & QSA)	324
ELECTRIC HEATING	228-247	STOCK REFERENCE & PRICE LIST INDEX	326-347
Bluethermal Underfloor Heating	230-235		
Heated Towel Rails	236-237		
Radiant Heaters	238-239		
Opal Aluminium Radiators	240		
Optimax Plus Panel Heater	241		
Optimax Plus Combination Heater	242		
Optimax Plus Storage Heater	243		
Plinth Heaters	244		
Warm Air Curtains	245		
Convactor Heater	246		
Portable Fan Heater	247		



Lo-Carbon Residential Fans



Continuing our commitment to energy efficiency in this section you will find Lo-Carbon solutions for intermittent and continuous fan applications.

In axial or centrifugal, wall, ceiling or window applications in bathrooms or kitchens we have a Lo-Carbon fan offering up to 90% energy saving over the equivalent traditional fan.

We are proud to be market leaders and continually strive to bring you the best products available. Our newest addition to the range is no different - the NEW Lo-Carbon Revive features a raft of innovations developed specifically for the needs of the Social Housing Market. The unique Multi-Vortex™ airflow technology ensures excellent pressure development yet efficient and quiet operation. Revive's Sense Smart™ intelligent technology makes the fan easy to install and provides a range of data via its easy to use interface. See page 20 for more details.

Vent-Axia®

	NEW Lo-Carbon Svava Axial Bathroom/Toilet Fan	10-11
	Lo-Carbon iQ Intelligent Axial Bathroom Fan	12-13
	Lo-Carbon VA100®/SELV Axial Bathroom/Toilet Fan	14-15
	Lo-Carbon Silhouette® 100/SELV Bathroom/Toilet Fan	16-17
	Lo-Carbon Centra®/SELV dMEV Unit	18-19
	NEW Lo-Carbon Revive /SELV Bathroom/Kitchen Filterless Fan	20-21
	Lo-Carbon Solo Plus/SELV Centrifugal Bathroom/Toilet Fan	22-23
	Lo-Carbon Minivent Ducted Bath/Shower Fan Kit	24
	Lo-Carbon LED Vent-A-light Ducted Bath/Shower Fan Kit	25
	Lo-Carbon Quadra®/SELV Centrifugal Fan	26-27
	Lo-Carbon Silhouette® 125 Bathroom/Toilet Fan	28
	Lo-Carbon VA150 Axial Kitchen & Utility Room Fan	29
	Lo-Carbon Silhouette® 150 Axial Kitchen Fan	30-31

NEW Lo-Carbon Svara

Features & Benefits

- The UK's first App controlled unitary fan!
- Set up and control through the App via Bluetooth
- Continuous or intermittent
- 1 model for all applications
- Silent hours scheduling and purge mode functions
- Intelligent light sensor with overrun timer - allows replacement of a basic model fan
- 3 Speed, IP44 Rated, DC motor with 5 year guarantee
- Suitable for ceiling, panel or wall mounting
- Only 17 dBA



The UK's first App controlled unitary fan

The launch of Svara marks the next generation of unitary fans.

For electricians, installation is made simple through Svara's Bluetooth-enabled App allowing you to choose whether to opt for intermittent or continuous ventilation; whether you would like the humidistat to trigger operation or not; and whether the overrun timer is required. No more fiddly switches and jumpers!



For consumers Svara offers improved comfort in their homes since it has been developed to allow households to take control of their indoor air quality via the App.

Aesthetics and silence

The name Svara takes its influence from the fan's Swedish heritage - a country well known for iconic and well thought out designs. Consumers will be attracted to Svara's good looks with its sleek modern design, plus with noise a key issue for consumers, households will also be impressed by Svara's quiet running, operating at just 17 dBA on low trickle. It is also easy to clean as the central module disconnects the motor from the rest of the fan allowing it to be simply wiped with a soft cloth, and at only 4W the energy efficient Svara also boasts low power consumption.

One model fits all

Vent-Axia Svara is programmed to cope with the vast majority of installations.

The fan is set as default to work continuously at a trickle flow of 10l/s.

When the fan senses a somebody in the room it increases the flow to 19l/s. If the humidity rises rapidly, for example when the shower is on, the fan goes up to maximum flow at 30l/s.

When the fan senses the humidity level has returned to normal it reverts to the trickle flow of 10l/s.

If other settings or functions are desired, they can be selected through the Vent-Axia Connect App which can be downloaded from the App Store and Google Play.

Functions

Light sensor

When the light sensor is enabled Svara senses when someone is in the room and then activates. Its sophisticated light sensor is triggered by light movement and shadows. It is possible to set a delay-on so the fan is not triggered by the light during quick night time bathroom visits. The light sensor can also distinguish between headlight flashes from cars and room occupancy, so it is not triggered by passing cars, avoiding nuisance running. The sensitivity of the light sensor can be adjusted via the App.

Overrun Timer

The light sensor provides an overrun timer but only requires a live and neutral. In houses where there is only a basic fan installed, the home owner can upgrade to a timer fan without having to rewire.

Humidistat

Svara features a humidistat which reacts to sharp changes in humidity, for instance when someone is taking a shower. When set to continuous running, once the humidity sensor is activated the fan runs at 30l/s until humidity returns to normal levels then the fan powers down to 10l/s. Ambient humidity changes will not trigger the humidistat. It is possible to change the sensitivity of the humidity sensor via the App.

Silent scheduling and Automatic cycles

The silent hours scheduling function allows you to deactivate the boost function on the Svara via the App, for example, this would prevent nuisance noise over night. Additionally during a vacation you can set Svara to an airing mode which operates a purge function every 12 hours for either 30, 60 or 90 minutes depending on selection. However, Svara's sophisticated controls, will not purge if the light sensor detects that there is someone in the house.

Models

Svara kitchen and bathroom fan

100 mm Axial fan. Factory set at continuous running with Humidistat and Light Sensor/overrun timer On.

Model	Stock Ref
Lo-Carbon Svara	409802

Accessories

Model	Stock Ref
Wall Kit	254102



Model	Stock Ref
Back draught shutter	406605



Cover plate

For duct dimensions between $\varnothing 140-160\text{mm}$

Model	Stock Ref
Cover plate	409820

Dimensions (mm)

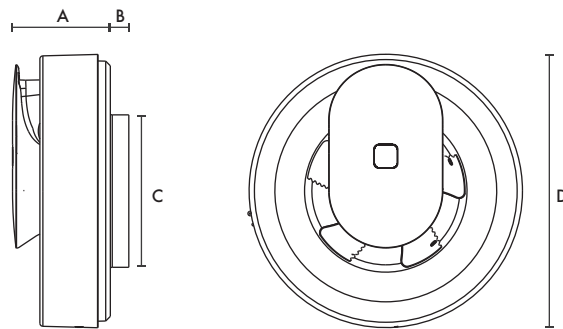

A	B	C \varnothing	D \varnothing
60	21	99	177

Performance Guide

Extract Performance - FID (l/s)				Sound dB(A) @ 3m	SFP (W/l/s) @ 0Pa
Low Trickle	High Trickle	Boost	Max Watts		
10	19	30	4	17-20	0.13

Lo-Carbon iQ

Features & Benefits

- Minimal retro design to match bathroom décor
- Extremely quiet- only 21 dB(A)
- Truly surface mountable with removable spigots
- Intelligent controls and control panel for easy and flexible set up and commissioning
- Low power consumption - only 5 W
- Easy cleaning and maintenance
- 5 year Lo-carbon motor guarantee
- Intelligent humidistat control as standard
- Innovative airing function to ensure good air quality
- IP44 rated



Market Leading Design

With the launch of the Lo-Carbon iQ fan, we not only spent time perfecting the operation and user's experience of the fan but also worked hard on the design. The result is a stylish fan with a surface depth that appeals to the eye and that matches modern fittings found in today's bathrooms. The visible blades give a retro-feel and helps to give the fan a very quiet noise level.

Silent Operation

The open impellor and the unique method of operating the motor enables a greater array of operating options including silent continuous ventilation along with adaptable speed control and flexible timer functions.

Humidity Control

The iQ features an intelligent, fully automatic humidity sensor for moisture control. This means the fan learns to run only when it can make a difference to the indoor air quality. The fan continually monitors and records the moisture content to allow it to map the humidity profile throughout the year. This process enables the fan to ensure that it runs only when the fan can lower the moisture content in the air. This reduces nuisance running. The fan also has two modes for moisture control, silent or boost mode which can be selected via the touch pad control.

Control Panel

Our aim has been for the end user to be able to control and understand the basic fan functions, without the need of reading the manual. When the fan is connected to the power supply, it also performs a self-test where all the status lamps on the control panel are tested, as well as the function of the motor. Ideal for those installing to ensure that everything works. The simple controls, along with the LED feedback make the commissioning and any readjustment, quick and easy to complete.



LED Feedback

With many fans it is difficult to understand the exact mode that they are running in. We have now simplified this to provide a visual indicator to see what the fan is doing and which mode is currently active. The fan uses three different colours on the visible status lamp to communicate exactly what it is doing. A blue light signifies that the fan is working to evacuate moisture via the humidity sensor. A yellow light signifies that the timer is running. And a purple light signifies that the fully automatic airing function is active.

You Choose How The Fan Works

The intelligent overrun timer can be operated in several different ways, either via the light switch, integral pull-cord or a separate switch either as a standard On/Off or as a momentary switch stopping automatically after the overrun on time. You use the control panel to easily set the required post-running time at 15 or 30 minutes, depending on your choice.

Full Surface Mounted Installation

With the impellor and motor assembly designed to be low profile and accessible for maintenance, spigots on the fan are completely removable. This design enables the fan to be mounted onto a wall without any spigot so that it can be truly surface mounted. This is an ideal function if you have a duct with a smaller dimension than 100 mm or a duct that bends directly off of the back of the fan not providing any depth in the wall for the spigot.

Cleaning and Maintenance

For a fan to ventilate effectively, it is vital that it is kept clean and that the ductwork and grilles are free from dust that can reduce the air flowing through them. This is the first fan to be introduced with the ability to simply remove the impellor and open the centre of the fan to gain free access to the duct. Using the 'swing-out' function you can easily clean and clear the fan e.g. a clogged grille on the outside of the façade. Click the button to remove the impellor, then press the snap in catch and swing out the motor - that's it!



Automatic Airing Function

The airing function means when the fan has been inactive for 26 hours, it runs an airing programme for 60 minutes to exchange the air in the bathroom. No more worries about stuffy, musty odours in the bathroom when returning from holiday.

Lo-Carbon 5 Year Guarantee

As there is an integrated power adapter in the fan we have been able to use a low voltage motor that has a life span of approximately 60,000 hours. This is about 3-5 times longer than a standard fan. The motor features extremely quiet bearings. By using a low voltage motor we can significantly limit power consumption. The fan only consumes 5 Watts, about a third of a conventional AC bathroom fan.

Models

Lo-Carbon iQ

Multi control fan with option to run on intermittent or continuous setting. Adjustable timer and humidity options with integral pullcord included.

Model **Lo-Carbon iQ** Stock Ref **405155**

Accessories



Backdraught Shutters

Designed to reduce any incoming draughts when the fan is off.

Model **Backdraught Shutters** Stock Ref **406605**



Wall Mounting Back Plate

Designed to cover up marks where a previous fan has a different foot print. 242mm x 190mm.

Model **Wall Mounting Back Plate** Stock Ref **406762**

Dimensions (mm)

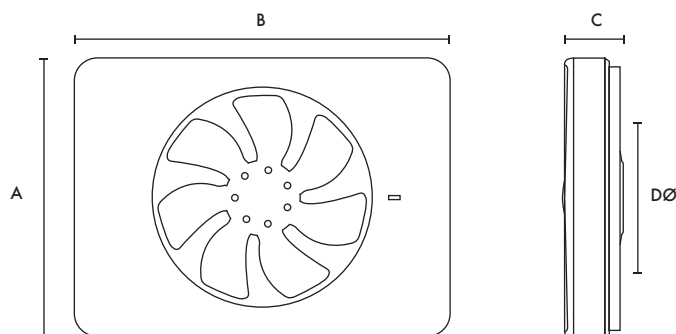

A	B	C	DØ
152	202	31	99/125

Product is supplied with a removable spigot 30mm deep in 99mmØ and 125mm Ø

Performance

Duct Ø	Trickle/Boost	Extract Performance - FID		Sound dB(A)
		m³/h	l/s	@ 3m
100mm	Max	108	30	28
100mm	Silent	72	20	21
100mm	Trickle	43.2	12	12
125mm	Max	133.2	37	29
125mm	Silent	86.4	24	21
125mm	Trickle	54	15	13

Lo-Carbon VA100/SELV

Features & Benefits

- Meets current Building Regulations Approved Document F & L
- Suitable for wall, ceiling, panel and window mounting
- Fitted with a motorised shutter
- Protected against low energy lighting circuits
- IPX4 rated - IPX7 rated (SELV)
- Efficient long life DC motor with 5 year guarantee
- Uses up to 87% less energy
- Low sound levels
- 1 of 2 speeds selectable at installation
- Low specific fan power
- Day logger as standard on all models



Long Life Ventilation VA100

The Vent-Axia Lo-Carbon VA100 range features Lo-Carbon long life DC motors that are more efficient than conventional motors delivering up to 87% energy savings.

Shutters

The Vent-Axia Lo-Carbon VA100 range is fitted with a motorised shutter mechanism that uses no extra power in operation or off.

Installation

Fitted with integral protection against low energy lighting circuits, the Lo-Carbon VA100 is a 100mm axial fan suitable for use in the bathroom or toilet. VA100 is quick and simple to fit with easy-wire in one line terminals. Suitable for installation in windows, walls or panels/ceilings using kits available. The 100mm telescopic wall kit fits walls 225 to 360mm thick. The range meets the requirements of the current Building Regulations for the ventilation of toilets 6l/s and bathrooms 15l/s with a 15 minute overrun timer for internal rooms on the LT, XT and HTP models.

Safety Extra Low Voltage (SELV) Fan

Safety Extra Low Voltage (SELV) is designed for areas where a fan has to be fitted within zone 1 in a room containing a fixed bath or shower according to IEE wiring regulations. The VA100 SELV can be safely installed within the spray area. The fan is rated IPX7, control is by the supplied mains safety isolating transformer with 12V DC SELV output, which is sited away from any source of spray and out of reach of a person using a fixed bath or shower.

Models

Lo-Carbon VA100 LP/SELV LP (Pullcord)

Ultra long life DC motor. Pullcord On/Off override switch with indication light. 2 speed options.

Model	Stock Ref
LP	443159
SELV LP	441614

Lo-Carbon VA100 XP/SELV XP (Shutter/Pullcord)

Ultra long life DC motor. Pullcord and On/Off override switch with indication light. 2 speed options.

Model	Stock Ref
XP	443160
SELV XP	459049

Lo-Carbon VA100 LT/SELV LT (Timer)

Electronic adjustable overrun timer (5-30 minutes). Indication light. 2 speed options.

Model	Stock Ref
LT	443161
SELV LT	441615

Lo-Carbon VA100 XT/SELV XT (Shutter/Timer)

Integral electronic adjustable overrun timer (5-30 minutes). Indication light. 2 speed options.

Model	Stock Ref
XT	443162
SELV XT	459050

Lo-Carbon VA100 LHTP/SELV LHTP (Integral Humidity Sensor/Pullcord/Timer)

Complete with integral humidity control with pullcord override. Indication light which operates on the manual override only. 2 speed options.

Model	Stock Ref
LHTP	443163
SELV LHTP	441616

Lo-Carbon VA100 XHTP/SELV XHTP (Shutter/Integral Humidity Sensor/Pullcord/Timer)

Complete with integral humidity control with pullcord override. Indication light which operates on the manual override only. IPX4 rated. 2 speed options.

Model	Stock Ref
XHTP	443164
SELV XHTP	436064

Accessories

Wall Kit

Fixing hole diameter 117mmØ

Model	Stock Ref
Wall Kit White	254102
Wall Kit Brown	254100

Window Kit

Fixing hole diameter 105mmØ

Model	Stock Ref
Window Kit	254101
Anti-tamper Window Kit	443234

Dimensions (mm)

Panel

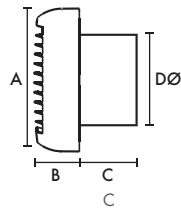
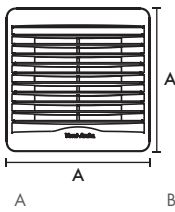

Wall

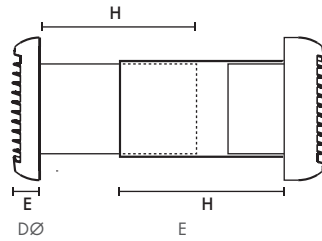

Window

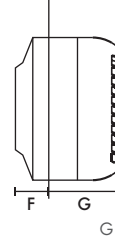

Bathroom/Toilet	A	B	C	DØ	E	F	G	H
	146	47	53	98	31	31	74	200
SELV Transformer (W x H x D) 87 x 87 x 33								
Weight 1 kg								

Performance

Area	Models	Extract Performance - FID			Sound dB(A)	SFP (W/l/s)
		m ³ /h	l/s	Watts	@ 3m	@ 0Pa
Toilet	Lo-Carbon VA100/SELV LP/XP/LHTP/XHTP/LT/XT	60	17	3.4	32	0.20
Bathrooms	Lo-Carbon VA100/SELV LP/XP/LHTP/XHTP/LT/XT	74	21	7.0	36	0.33

Lo-Carbon Silhouette 100/SELV

Features & Benefits

- Models Basic/Timer/Humidity & Timer
- Low power consumption - Lower running costs
- Fully opening and closing non-transparent shutters - Improved insulation and privacy
- Meets current Building Regulations Approved Document F & L
- 1 of 2 speeds selectable at installation
- Blue power indication light (except B model) - Modern aesthetics
- Ball bearing motors for vertical or horizontal application
- Unique humidity sensor track - Improved response
- 5 Year Motor Guarantee
- IPX4 rated - IPX7 rated (SELV)
- Suitable for wall, ceiling, panel and window mounting



Slimline Bathroom Ventilation

With a slim profile of only 17mm, Lo-Carbon Silhouette blends in with the wall surface to provide an unobtrusive installation. Lo-Carbon Silhouette has an FID performance of up to 30l/s. It can be ceiling/panel mounted and connected to an appropriate duct run to the outside.

Safety Extra Low Voltage (SELV) Fan

Safety Extra Low Voltage (SELV) is designed for areas where a fan has to be fitted within zone 1 in a room containing a fixed bath or shower according to IEE wiring regulations. The Silhouette SELV can be safely installed within the spray area. The fan is rated IPX7, control is by the supplied mains safety isolating transformer with 12V DC SELV output, which is sited away from any source of spray and out of reach of a person using a fixed bath or shower. SELV transformer to BS EN 60742.

Models

Lo-Carbon Silhouette 100B/SELV 100SVB

100mm bathroom/toilet fan with back draught shutter.

Model	Stock Ref
100B	441624
SELV 100SVB	441511

Lo-Carbon Silhouette 100T/ SELV 100SVT (Timer)

100mm bathroom/toilet fan with integral adjustable electronic overrun timer (5-30 minutes), indicator light which operates on manual override only, and back draught shutter.

Model	Stock Ref
100T	441625
SELV 100SVT	441512

Lo-Carbon Silhouette 100HT (Humidistat/Timer)

100mm bathroom/toilet fan with adjustable auto humidity sensor from 60-90% RH and overrun timer, indicator light which operates on manual override only, and back draught shutter. Datalogger as standard on all Lo-Carbon humidity controlled Silhouette fans.

Model	Stock Ref
100HT	441626

Lo-Carbon Silhouette 100H SELV (Humidistat)

100mm bathroom/toilet fan with ambient response humidity sensor from 60-90% RH, indicator light which operates on manual override only, and back draught shutter.

Safety Extra Low Voltage version.

Model	Stock Ref
SELV 100SVH	441513

Accessories

Wall Kit

Fixing hole diameter 117mmØ

Model	Stock Ref
Wall Kit White	254102
Wall Kit Brown	254100

Window Kit

Fixing hole diameter 117mmØ

Model	Stock Ref
Window Kit	442947



17mm actual profile

Dimensions (mm)

Panel

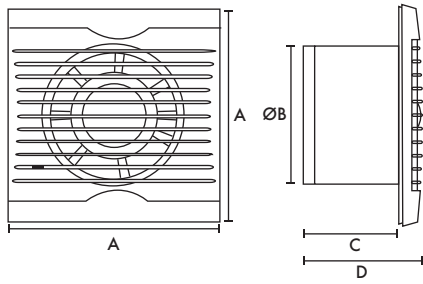

Wall Kit

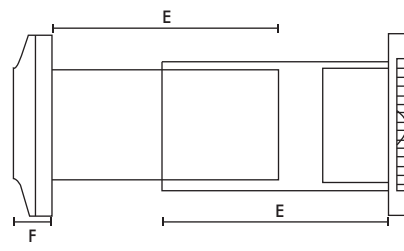

A	BØ	C	D	E	F
160	99	115	132	200	32

SELV Transformer (W X H X D) 87 X 87 X 33

Weight 0.6kg

Performance Guide

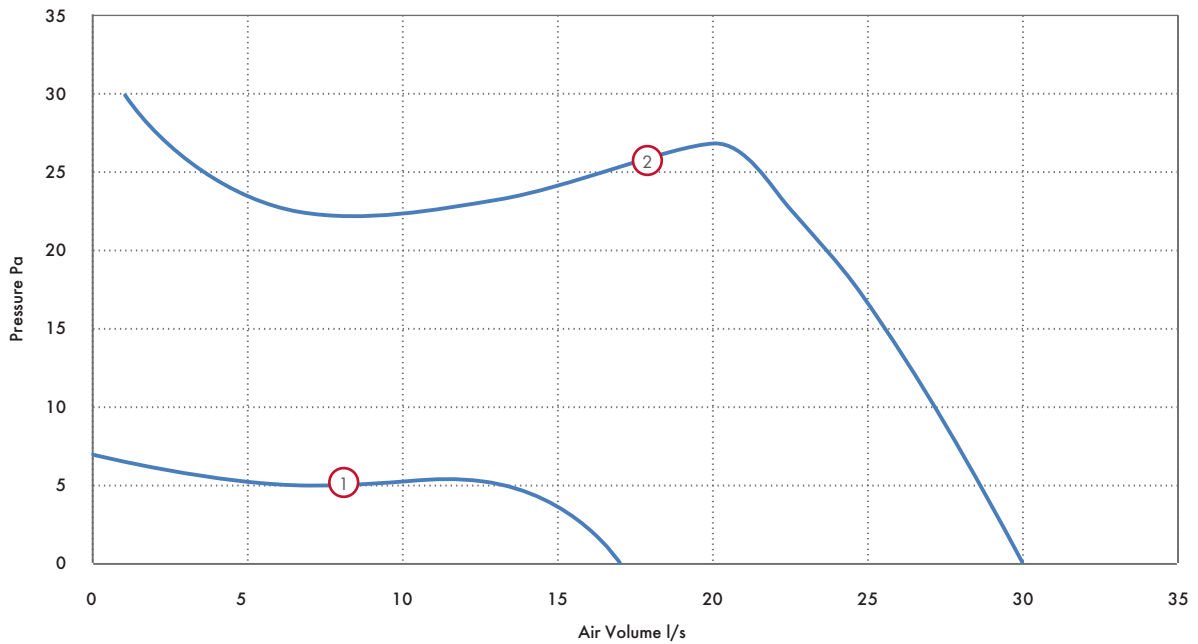

Area	Model	Curve Ref	Extract Performance - FID			Sound dB(A)	SFP (W/l/s)
			m ³ /h	l/s	Watts	@ 3m	@ 0Pa
Toilet	Lo-Carbon Silhouette 100 B/T/HT/SVB/SVT/SVH	1	60	17	3.4	34	0.20
Bathrooms		2	108	30	8.7	38	0.30

For window mounting: shutter cannot be used and must be removed

Lo-Carbon Centra/SELV

Features & Benefits

- Building Regulations Approved Documents F and L compliant, System 3 Continuous mechanical extract
- Recognised in SAP PCDB - Low SFP
- Discreet, tasteful styling
- IPX4 rated - IPX7 rated (SELV)
- dMEV Pressure detection device
- 5 Year Motor Guarantee
- Suitable for wall, ceiling, panel and window mounting
- SELV models supplied with remote transformer and suitable for 'Zone 1'



Winners of the Energy Efficiency Initiative 2011 Award with our Lo-Carbon Continuous Ventilation Product Range

What is de-centralised MEV (dMEV)?

Building Regulations Approved Document F gives examples of four main methods of ventilation. System 3, Continuous mechanical extract ventilation, can be achieved using a single centralised extract unit such as the Sentinel Multivent ducted to 'wet' rooms (kitchen, bathroom, ensuite and WC) or by decentralised individual fans, such as the Lo-Carbon Centra in the 'wet' rooms. The fans run continuously at near silent levels providing a simple and effective form of ventilation.

SELV (Safety Extra Low Voltage) is designed for areas where a fan can be installed within Zone 1 in a room where there is a fixed bath or shower. Ingress Protected (IP) to IPX7 Lo-Carbon Centra SELV can be fitted safely within the spray area. The separate transformer can be mounted away from the spray zone and out of reach from the bath or shower.

The Lo-Carbon Centra meets the latest requirements of the Building Regulations Approved Document F for wholehouse system ventilation and all models come with a 5 year motor guarantee.

Selection of the two trickle flow rates (6l/s or 9l/s) is via a simple 'jumper' on the control board. Different methods are available for operating the 15 l/s boost speed from a simple switched live to integral humidistat. See individual models for further details.

The attractive and discreet styling of the Vent-Axia Lo-Carbon Centra will complement the décor of any new home while virtually silent operation ensures optimum ventilation is achieved without intrusive noise.

Specific Fan Power

dMEV version recognised in SAP PCDB. Lo-Carbon Centra has a specific fan power of only 0.18 W/l/s in through-the-wall kitchen applications.

Models

Lo-Carbon Centra dMEV

Auto speed selection at installation and suitable for bathrooms or kitchens. The integral air pressure sensor checks the airflow when first installed and also helps the fan to compensate for external wind pressure.

Stock Ref

441782

Lo-Carbon Centra T/SELV T (Timer)

Ideal for bathroom and toilet applications, this unit runs continuously on trickle setting and may be boosted by the switched live input which activates the timer (fixed 15 min on T models, adjustable 5-30 minutes on SELV models).

Model	Stock Ref
T	442954
SELV T	443175

Lo-Carbon Centra TP/SELV TP (Timer/Pullcord)

For bathroom/toilet applications, the continuous running TP model is boosted by the pullcord which activates the timer (fixed 15 min on TP models, adjustable 5-30 minutes on SELV models).

Model	Stock Ref
TP	447127
SELV TP	447128

Lo-Carbon Centra HT/SELV HT (Humidistat/Timer)

For bathroom/toilet applications, the continuous running HT model is automatically boosted by the built-in humidistat or by a switched live input which activates the timer (fixed 15 min on HP models, adjustable 5-30 minutes on SELV models).

Model	Stock Ref
HT	442955
SELV HT	443176

Lo-Carbon Centra HTP/SELV HTP (Humidistat/Timer/Pullcord)

For bathroom/toilet applications, the continuous running HTP model is automatically boosted by the built-in humidistat or by the pullcord which activates the timer (fixed 15 min on HTP models, adjustable 5-30 minutes on SELV models).

Model	Stock Ref
HTP	443045
SELV HTP	443177

Accessories

Model	Stock Ref
150mm Conversion Kit	443334
Wall Kit White	254102
Wall Kit Brown	254100
Window Kit	442947
Ceiling Kit	443800

Dimensions (mm)

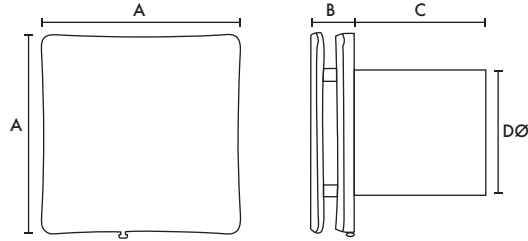

Model	A	B	C	DØ
Lo-Carbon Centra dMEV/All SELV	160	35	115	99
Lo-Carbon Centra T/TP/HT/HTP	160	35	80	99

Transformer 87 x 87 x 33mm (W x H x D) (SELV models only)

Performance Guide

Model	Extract Performance (l/s)			Power Consumption (Watts)			Sound dB(A)@ 3m		
	Trickle	Trickle	Boost	Trickle	Trickle	Boost	Trickle	Trickle	Boost
	Low	High		Low	High		Low	High	
Lo-Carbon Centra dMEV/All SELV	6	9	15	1.4	1.6	2.4	10.8	15.5	25.2
Lo-Carbon Centra T/TP/HT/HTP	6	9	15	3.2	3.5	4.2	10.8	15.5	25.2

SAP PCDB Performance (dMEV model)

Systems With Rigid Ductwork Installation Only

Unit Configuration	Location	Fan Speed Setting	Flow Rate (l/s)	SFP (W/l/s)
In Room (Ducted)	Kitchen	High	13.2	0.32
In Room (Ducted)	Wet Room	9 l/s	8.4	0.28
Through Wall	Kitchen	High	13.5	0.18
Through Wall	Wet Room	9 l/s	8.6	0.20

Systems With Flexible Or Mixed Ductwork Installation Only

Unit Configuration	Location	Fan Speed Setting	Flow Rate (l/s)	SFP (W/l/s)
In Room (Ducted)	Kitchen	High	13.2	0.37
In Room (Ducted)	Wet Room	9 l/s	8.6	0.31
Through Wall	Kitchen	High	13.5	0.18
Through Wall	Wet Room	9 l/s	8.6	0.20

NEW Lo-Carbon Revive/SELV

Features & Benefits

- Designed specifically with Social Housing in mind
- Continuous running bathroom and kitchen fan
- Extracts up to 60l/s
- Easy to read LED display for commissioning and data gathering
- Intelligent Smart Sense™ technology tells you days run, boost hours run, energy used
- Innovative Multi-Vortex technology ensure high performance but low sound and energy levels
- 5 or 7 year warranty options
- Small footprint with optional decoration frame



Designed for Social Housing

The intelligent Lo-Carbon Revive is a new filter-less unitary fan designed to meet the specific needs of social housing. Boasting powerful, quiet, efficient ventilation, Revive provides good indoor air quality and comfort for residents while being quick and easy to install, low maintenance and reliable.

Smart Sense™ technology

Featuring Smart Sense™ intelligent technology Revive is quick and easy to install due to its simple alpha numeric LED display which is clear, easy to read and has a three-button menu for commissioning and data gathering. Smart Sense™ technology even tells the LED display which orientation to use depending on whether it is wall or ceiling mounted. All of which saves time on site and reduces installation complications.

The display also shows real-time data so landlords can reassure residents of the low-running costs. This includes data such as days run, hours on trickle or boost, and even more specifically, hours run on boost triggered by the humidity sensor. Revive can also tell you how much energy the fan has used.

Multi-Vortex™ technology

Revive is low maintenance since its market-leading Multi-Vortex™ technology does not require a filter, while the highly sculpted interior actively repels dust, avoiding clogging, thus helping to avoid call backs. In addition the Multi-Vortex™ technology has a high-pressure hybrid impeller that is powerful and efficient, yet quiet – everything you need for the Social Housing resident.

Multiple configuration options

Revive can extract up to 60l/s from a kitchen, but upon installation you have the choice to change the setting to allow for installation in a bathroom. The installer can also select a ducted mode or a through the wall mode. All selected via the intuitive LED display.

Models



Lo-Carbon Revive 7/SELV 7

HTP continuous running fan with kitchen or bathroom setting, with a combination of trickle and boost speeds selectable from 9, 15, 30 and 60l/s. Day logger and power run meter as standard. 7 year warranty. Adjustable dynamic ambient response humidity sensor. Timer adjustable between 1 and 30 minutes. In built boost activated by pullcord, humidity sensor, switched live or remote button. Tile front for discreet installation.

Model	Stock Ref
Lo-Carbon Revive 7	473848
Lo-Carbon Revive SELV 7	473849



Lo-Carbon Revive 5/SELV 5 - Available Winter 2016

HTP continuous running fan with kitchen or bathroom setting, with a combination of trickle and boost speeds selectable from 9, 15, 30 and 60l/s. Day logger and power run meter as standard. 5 year warranty. Adjustable dynamic ambient response humidity sensor. Timer adjustable between 1 and 30 minutes. In built boost activated by pullcord, humidity sensor, switched live or remote button. Open front grille.

Model	Stock Ref
Lo-Carbon Revive 5	473850
Lo-Carbon Revive SELV 5	473851



Lo-Carbon Revive/SELV - Available Winter 2016

HTP continuous running fan with kitchen or bathroom setting, with a combination of trickle and boost speeds selectable from 9, 15, 30 and 60l/s. 5 year warranty. Adjustable dynamic ambient response humidity sensor. Timer adjustable between 1 and 30 minutes. In built boost activated

by pullcord, humidity sensor, switched live or remote button. Open front grille.

Model	Stock Ref
Lo-Carbon Revive	473852
Lo-Carbon Revive SELV	473853

Accessories

Model	Stock Ref
Wall Kit White	254102
Wall Kit Brown	254100
Conversion kit	408680
Ceiling kit	407928
Window kit	407927
Decoration Frame	474041

Dimensions (mm)

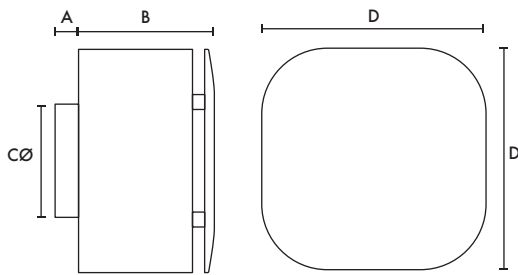

A	B*	CØ	D
30	132/102	99	193

*Closed/Open Grille

Decoration Frame Dimensions (mm)

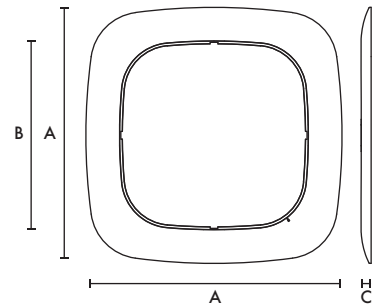

A	B	C
259	191	10

Performance Guide

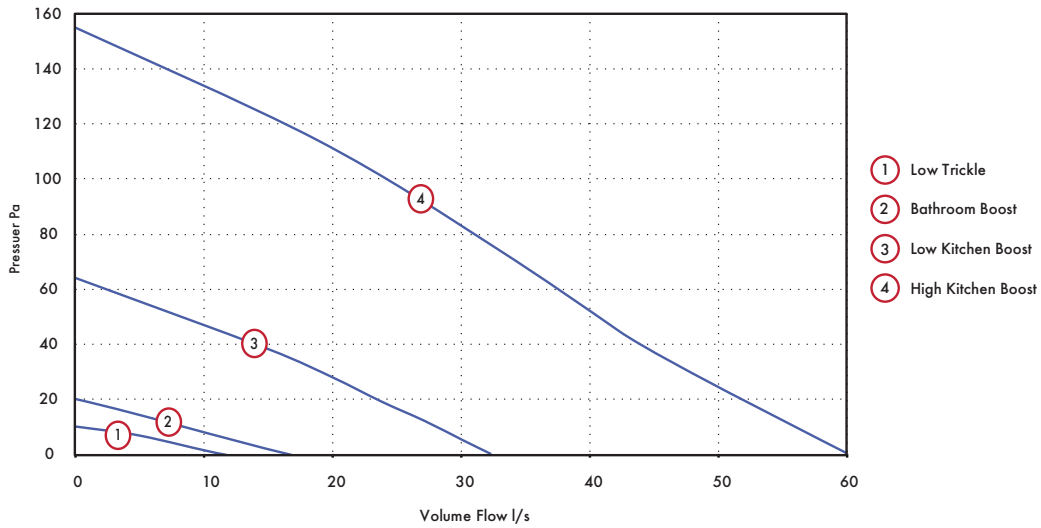

Model	Extract Performance (l/s)				Power Consumption (Watts)			
	Trickle Low	Bathroom Boost	Low Kitchen Boost	High Kitchen Boost	Trickle Low	Bathroom Boost	Low Kitchen Boost	High Kitchen Boost
Revive	9	15	30	60	1.4	2	6	26

Lo-Carbon Solo Plus/SELV

Features & Benefits

- Up to 70% energy saving
- Filterless as standard - innovative impeller design means no need for a filter
- 5 Year Lo-Carbon motor guarantee
- Meets current Building Regulations Approved Documents F & L
- IPX4 rated - IPX7 rated (SELV)
- Flush or surface mountable with adjustable rear or side exit spigot
- SELV models suitable for installation over or within reach of a shower or bath
- Extremely low sound levels
- Suitable for wall, ceiling and panel mounting
- SELV Models - Supplied with a remote transformer



Long Life Ventilation

The Lo-Carbon Solo Plus range from Vent-Axia has been specially designed for through the wall and ducted applications, suitable for internal bathrooms, toilets and other small rooms. Finished in white, the Lo-Carbon Solo Plus can be flush or surface mounted, with a 2 position 100mm circular spigot for rear entry or connecting to a vertical ducting system. The powerful centrifugal impeller allows installations using 100mm ducting in straight runs, whilst still achieving 15l/s as required by Building Regulations Approved Document F.

Continuous running products, such as the Lo-Carbon Solo Plus, installed in all wet areas of a dwelling are classed as a wholehouse ventilation system and therefore only need to move the amount of air as outlined in table 5.1a and 5.1b of Building Regulations Approved Document F.

The Lo-Carbon Solo Plus has an adjustable boost speed which is set at installation variable between a wall or duct setting for boost/override operation to meet Building Regulations thus ensuring minimum energy usage and low sound levels. All models have an optional speed for constant trickle ventilation (12l/s), selectable at installation. Depending on the model, the fan will switch from trickle (if selected) to boost via the pullcord/light switch/humidity sensor/PIR.

All models can be wall, panel or ceiling mounted and can be connected to either circular, rectangular or Vent-Axia's flat ducting. Enclosure of the electrical components is manufactured from flame retardant grade material.

Safety Extra Low Voltage Fan (SELV)

Designed for areas where a fan has to be fitted over or within Zone 1 in a room containing a fixed bath or shower according to IEE wiring regulations (BS 7671), the Lo-Carbon Solo Plus SELV fan can be safely installed within the spray area. The fan is rated IPX7. Control is by the supplied mains safety isolating transformer unit with 12V DC SELV output, which is sited away from any source of spray and out of reach of a person using a fixed bath or shower. Controller Supply voltage 220-240V/1/50Hz. Output to fan SELV 12V DC.

Models

Lo-Carbon Solo Plus P/SELV P (Pullcord)

Flush or surface mountable. Control by Pullcord. 2 Speed. Constant trickle option. Adjustable boost. In-built Lo-Carbon controller.

Model	Stock Ref
P	427481
SELV P	427485

Lo-Carbon Solo Plus T/SELV T (Timer)

Flush or surface mountable. Control by room light or switch. 2 Speed. Constant trickle option. Adjustable boost. Adjustable timer overrun. Delay on timer. In-built Lo-Carbon controller.

Model	Stock Ref
T	427482
SELV T	427486

Lo-Carbon Solo Plus HT/SELV HT (Humidistat/Timer)

Flush or surface mountable. Humidity controlled fan with override pullcord. Constant trickle option. Adjustable boost. Adjustable timer overrun. Delay on timer. Adjustable humidity sensor. In-built Lo-Carbon controller. Datalogger as standard on all Lo-Carbon humidity controlled Solo Plus fans.

Model	Stock Ref
HT	427483
SELV HT	427487

Lo-Carbon Solo Plus TM/SELV TM (Timer/PIR)

Flush or surface mountable. Control by integral PIR detector. 2 Speed. Constant trickle option. Adjustable boost. In-built Lo-Carbon controller.

Model	Stock Ref
TM	427484
SELV TM	427488

Accessories

Lo-Carbon Solo Plus Bezel

Used when flush mounting - reduces the need to make good.

Model Stock Ref
 Bezel 404106

Model Stock Ref
 Wall Kit White 254102
 Wall Kit Brown 254100

Filter pack (1 per pack)

The design of the Lo-Carbon Solo Plus means that it does not need a filter. However, if you are going to install the product in a heavily greasy environment, you may want to protect the product by fitting a filter.

Model Stock Ref
 Filter pack 449265

Dimensions (mm)

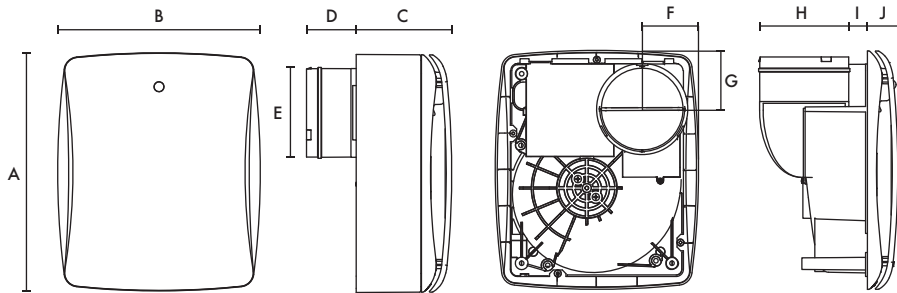

A	B	C	D	EØ	F	G	H	I	J
263	224	106	55	98	62	65	98	21	34

Weight 2.2kg, SELV Weight 2.7kg. Dimensions: (W x H x D) 87x87x33mm.

Performance Guide (Duct Mode)

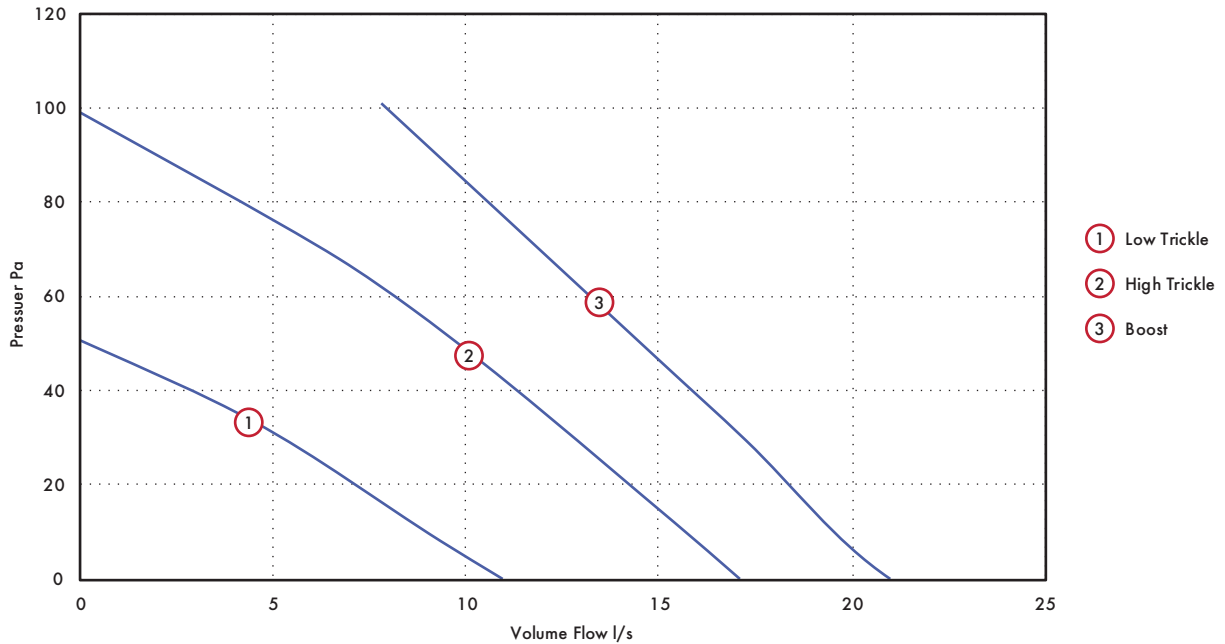

Model		Extract Performance l/s (m³/h)			Power consumption - Watts			dB(A) @ 3m			SFP (W/l/s)
		Boost	High trickle	Low Trickle	Boost	High trickle	Low Trickle	Boost	High trickle	Low Trickle	@ OPa
Lo-Carbon Solo Plus/SELV P/T/HT/TM	Wall mode	18 (64.8)	12 (43.2)	8 (28.8)	6	2.9	2.3	33.5	27	23.5	0.28
	Duct mode	21 (75.6)	17 (61.2)	11 (39.6)	8.4	5.3	3.2	35.5	33	26	0.29

Tested at 240VAC @ 50Hz

Lo-Carbon Minivent

Features & Benefits

- Complete kit supplied
- Meets Building Regulations Approved Document F & L requirements for toilets and bathrooms at max 1.5m of ducting and 1x 90° bend
- Adjustable timer version available
- 5 Year Motor Guarantee
- 1 of 2 speeds selectable at installation



Powerful Lo-Carbon In-Line Fan Kit

The Vent-Axia Lo-Carbon Minivent ducted bath/shower kit includes all the components necessary to install a ducted 100mm system. This simplifies fitting of an efficient ventilation system to small rooms including bathrooms, shower rooms and toilets. It is especially suitable for en-suite bathrooms.

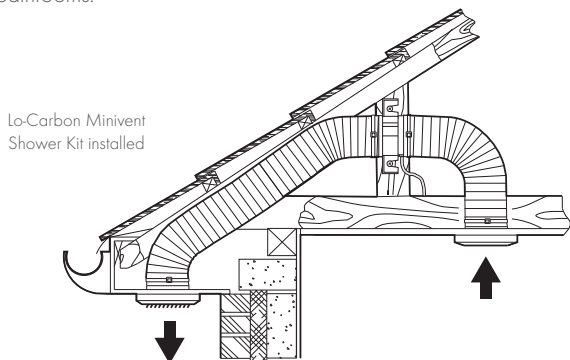

Lo-Carbon Minivent Shower Fan (Timer)

Comprises - high output tube fan, 3 metres of flexible duct, ceiling inlet grille and spigot, soffit/wall outlet grille.

Model Stock Ref
 Timer 441422

Dimensions (mm)

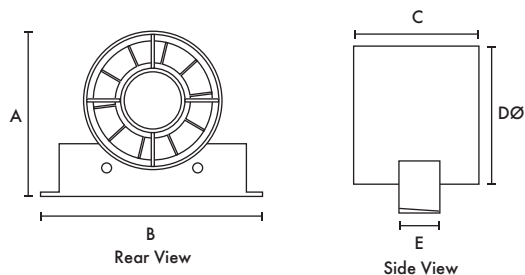

A	B	C	DØ	E
130	155	90	98	27

Internal/External Grille Dimensions 140x140mm
 Transformer (W x H x D) 87 x 87 x 33

When installed, the fan kit has ample performance to meet the Building Regulations requirements for toilets and bathrooms. The timer version should be used for internal rooms.

The kit consists of a Lo-Carbon Minivent In-Line fan, a white ceiling grille and spigot, 3 metres of flexible duct and an external louvre for soffit or wall mounting. The duct should be cut to the required length and the bend radius kept to a maximum to provide optimum fan performance.

Enclosed terminal compartment, Class 2 appliance. Supply voltage 220-240/1/50Hz.

Performance Guide

Model	Extract performance - FID			Sound dB(A) @ 3m	SFP (W/l/s) @ OP _a
	m ³ /h	l/s	Watts		
Lo-Carbon Minivent B/T	110	31	6.5	23	0.21

Models

Lo-Carbon Minivent Shower Fan (Basic)

Comprises - high output tube fan, 3 metres of flexible duct, ceiling inlet grille and spigot, soffit/wall outlet grille.

Model Stock Ref
 Basic 441421

Lo-Carbon LED Vent-A-Light

Features & Benefits

- Suitable for shower enclosure and wet areas
- Now with a 3W LED Lamp
- Provides simultaneous fan and light operation
- Meets current Building Regulations Approved Documents F & L
- 1 of 2 speeds selectable at installation
- Double insulated fan
- Light assembly Class III
- 5 Year Motor Guarantee
- Supplied with white and chrome bezels



100mm Lo-Carbon axial in-line shower fan and light kit. Provides simultaneous fan and light operation. Suitable for shower enclosures and wet areas. Available with both a white and chrome bezel on light assembly. The light assembly can be held in place using fixing clips or screws.

Typical Specification

CE marked in accordance with all the relevant EEC Harmonised Directives.

Fan double insulated and the motor is fitted with Thermal Protection. Light assembly class III.

Electrical

12 volt DC 3W GU5.3 sealed lamp. Powered by an LED Driver.

LED lamp lumens output 180lm - 200lm

Input, AC. Output - 12 volt DC. 1A.

Models

Lo-Carbon Vent-A-Light Fan and LED Light Kit (Basic)

100mm axial in-line shower fan and light kit. Includes fan, 3m flexible ducting, white grille, LED lamp light transformer and light assembly with white and chrome bezels.

Model Stock Ref
Basic **441423**

Lo-Carbon Vent-A-Light Fan and LED Light Kit (Timer)

100mm axial in-line shower fan and light kit. Fan has electronic overrun timer adjustable from 5 to 30 minutes. The factory setting is 15 minutes. Includes fan, 3m flexible ducting, white grille, LED lamp light transformer and light assembly with white and chrome bezels.

Model Stock Ref
Timer **441424**

Dimensions (mm)

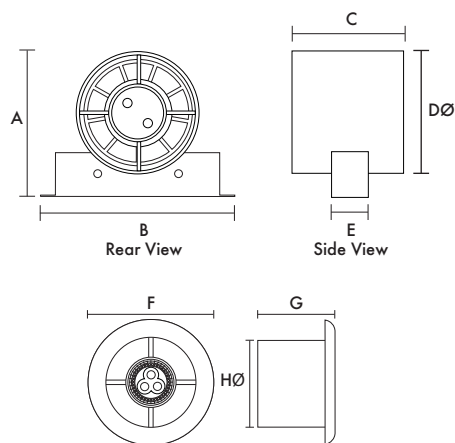

A	B	C	DØ	E	FØ	G	HØ
130	155	90	98	27	140	74	98

Internal/External Grille Dimensions 140x140mm

Fan Transformer (W x H x D) 87 x 87 x 33

Performance Guide

Model	Extract performance - FID		Fan Watts	Light Watts	Sound dB(A) @ 3m	SFP (W/l/s) @ 0Pa
	m ³ /h	l/s				
Lo-Carbon Vent-A-Light B/T	110	31	6.5	3	23	0.21

Tested at 240V 50Hz

Lo-Carbon Quadra/SELV

Features & Benefits

- Meets current Building Regulations Approved Document F & L for intermittent or continuous use
- Recognised in SAP PCDB - Low SFP on PCDB 0.38 W/l/s
- 100mm circular spigot for easy installation and replacement of any existing fan - flush or surface mount
- Filterless technology and maintenance free
- Lo-Carbon motors offering 90% energy savings and long life
- Motor cassette cartridge for simple replacement
- Integral daylogger (option on SELV models)
- 5 Year Motor Guarantee
- IPX4 rated - IPX7 rated (SELV)
- Suitable for wall, ceiling and panel mounting



the ELECTRICAL
industry awards
WINNER 2011

Winners of the Energy Efficiency Initiative 2011 Award
with our Lo-Carbon Continuous Ventilation Product Range.

Ventilation for any room

The Lo-Carbon Quadra offers a single fan suitable for surface or flush mounting. Low speed selectable between 6, 9 and 12l/s and high between 15, 30 and 60l/s all with through the wall or two ducted selections to ensure installed performance is met.

Lo-Carbon Quadra SELV

The Lo-Carbon Quadra SELV has been designed to meet building requirements where there is a need to fit in Zone 1 containing a fixed bath or shower according to IEE wiring regulations. The Lo-Carbon Quadra SELV can be safely installed within the spray area with the 24VDC Safety Isolating Power Supply situated away from the spray zone and out of reach of the person using the facility.

Discrete

With discrete aesthetics and low noise levels due to an accurately balanced impeller, it is also one of the most unobtrusive centrifugal kitchen fans available. The front cover design also provides no area for dirt to build up so it stays looking better for longer.

Models

Lo-Carbon Quadra TP/SVTP (Timer/Pullcord)

Dual speed: continuous running or intermittent to high speed. High speed via pullcord (On/Off) or switch live (with overrun timer).

Model	Stock Ref
TP	439251
SVTP	442865
SVTP Datalogger	446269

Lo-Carbon Quadra HTP/SVHTP (Humidistat/Timer/Pullcord)

Dual speed: continuous running or intermittent to high speed. High speed via integral pullcord (On/Off), integral adjustable humidity sensor or switch live (with overrun timer). When humidity sensor is triggered the flow rate increases proportionally with %RH to 50% of the set Boost speed.

Model	Stock Ref
HTP	439181
SVHTP	442866
SVHTP Datalogger	446270

Lo-Carbon Quadra TM/SVTM (Timer/PIR)

Dual speed: continuous running or intermittent to high speed. High speed via integral PIR sensor or switch live (both with overrun timer).

Model	Stock Ref
TM	439253
SVTM	442867

Accessories

Model	Stock Ref
Flush Mounting Kit	439256
Filter (optional)	439927
Decoration Frame	442551
Wall Kit White	254102
Wall Kit Brown	254100

Dimensions (mm)

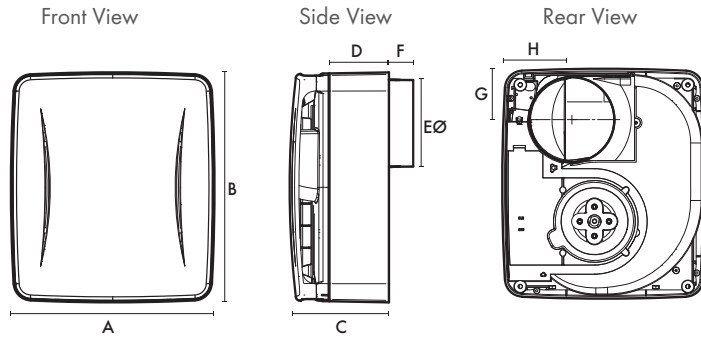

A	B	C	D	EØ	F	G	H
230	260	112	67	98	27	58	79

Performance Guide*

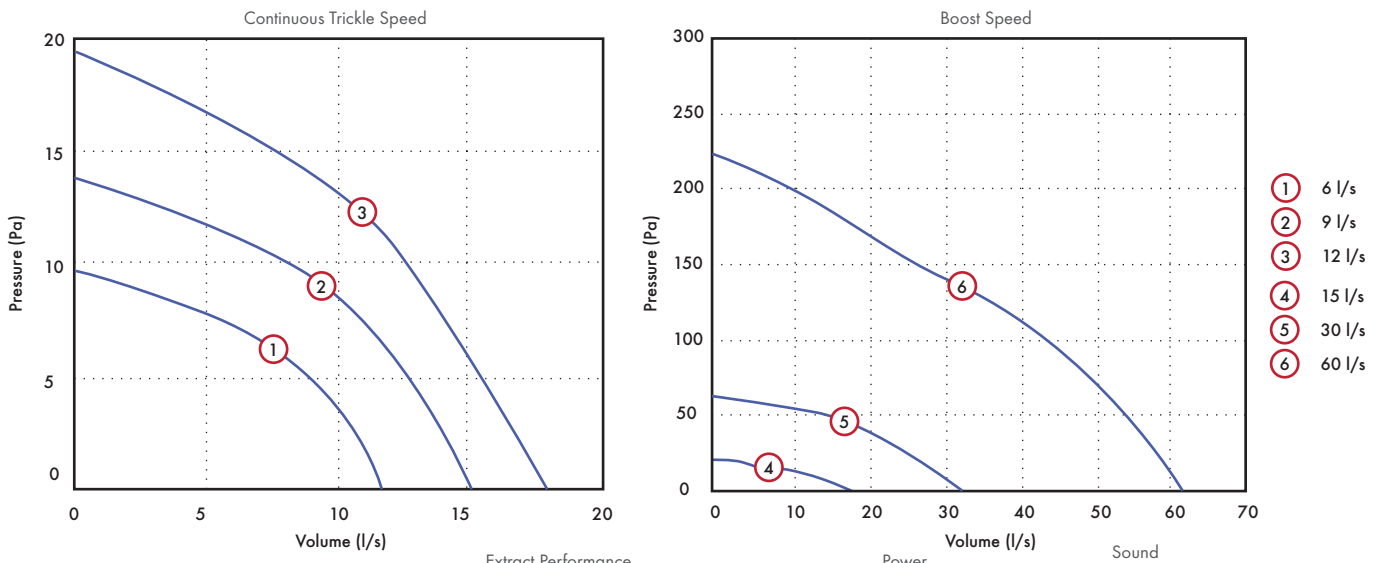

Model	Extract Performance		Power		Sound		SEC Class		
	m ³ /h	l/s	High	Low	High	Low			
Lo-Carbon Quadra/SELV TP/ HTP/ TM	223	63	22	6	38	3.8	50	20	D

*FID Performance. Tested in through the wall installation

SAP PCDB Performance

Systems With Rigid Ductwork Installation Only

Unit Configuration	Location	Fan Speed Setting	Flow Rate (l/s)	SFP (W/l/s)
In Room	Kitchen	15 l/s	15.8	0.41
In Room	Wet Room	9 l/s	14.6	0.61
Through Wall	Kitchen	15 l/s	21.4	0.38
Through Wall	Wet Room	9 l/s	19.5	0.50

Systems With Flexible Or Mixed Ductwork Installation Only

Unit Configuration	Location	Fan Speed Setting	Flow Rate (l/s)	SFP (W/l/s)
In Room	Kitchen	15 l/s	13.7	0.41
In Room	Wet Room	9 l/s	12.9	0.63
Through Wall	Kitchen	15 l/s	21.4	0.38
Through Wall	Wet Room	9 l/s	19.5	0.50

Lo-Carbon Silhouette 125

Features & Benefits

- Models Basic/Timer/Humidity & Timer
- Low power consumption - Lower running costs
- Quiet running
- Fully opening and closing non transparent shutters - Improved insulation and privacy
- 1 of 2 speeds selectable at installation
- IPX4 rated
- Ball bearing motors for vertical or horizontal application
- Unique humidity sensor track - Improved response
- 5 Year Motor Guarantee
- Suitable for wall, ceiling and panel mounting



Slimline Bathroom Ventilation

With a slim profile of only 18mm, Lo-Carbon Silhouette blends in with the wall surface to provide an unobtrusive installation. Lo-Carbon Silhouette has a FID performance up to 160m³/h. It can be ceiling/panel mounted and connected to an appropriate duct run to the outside.

Models

Lo-Carbon Silhouette 125B

125mm bathroom/toilet fan with indicator light and back draught shutter.

Model 125B Stock Ref 446483

Lo-Carbon Silhouette 125T (Timer)

125mm bathroom/toilet fan with integral adjustable electronic overrun timer (5-30 minutes), indicator light which operates on manual override only, and back draught shutter.

Model 125T Stock Ref 446484

Lo-Carbon Silhouette 125HT (Humidistat/Timer)

125mm bathroom/toilet fan with integral adjustable auto humidity sensor from 60-90% RH and overrun timer, indicator light which operates on manual override only, and back draught shutter. Datalogger as standard on all Lo-Carbon humidity controlled Silhouette fans.

Model 125HT Stock Ref 446485

Accessories

Model Wall Kit Stock Ref 455226

Dimensions (mm)

Panel

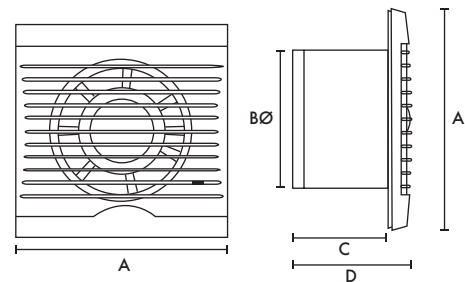

A	BØ	C	D
187	125	131	149

Performance Guide

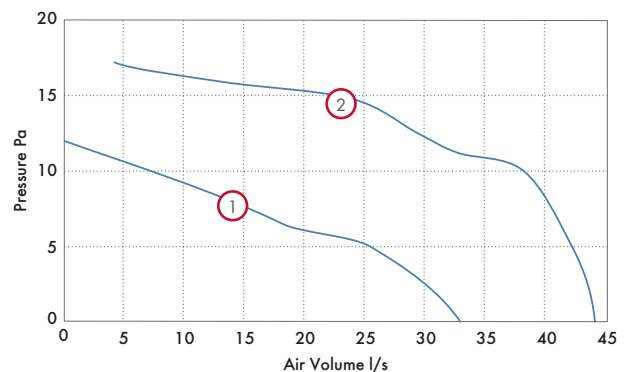

Model	Curve Ref	Extract Performance			Sound dB(A) @ 3m	SFP (W/l/s) @ 0Pa
		m ³ /h	l/s	Watts		
Lo-Carbon Silhouette	Low ①	120	33	4.5	33	0.14
125B/T/HT	High ②	160	44	8	37	0.18

Lo-Carbon VA150

Features & Benefits

- Reduces the home's carbon footprint
- Long life Lo-Carbon motor lasts up to 5 times longer than conventional motors
- Up to 60% energy saving
- Meets current Building Regulations Approved Document F & L when installed
- IP44 rated
- Low sound levels
- 5 Year Motor Guarantee
- Suitable for wall, ceiling, window and panel mounting
- Fitted with a motorised shutter
- 1 of 2 speeds selectable at installation



Long Life Ventilation

Vent-Axia Lo-Carbon VA150 fans feature Lo-Carbon long life DC energy saving motors that last up to 5 times longer than conventional motors, whilst delivering up to 60% energy savings. The extended life of Lo-Carbon fans is due to the use of a new generation of high quality electronically controlled ball-bearing motors especially developed for this range. The motors are perfectly designed for the wet conditions of utility rooms and kitchens, extracting stale, moisture-laden air quietly and efficiently.

Shutters

The Vent-Axia Lo-Carbon VA150 range is fitted with a motorised shutter mechanism that uses no extra power in operation or off.

Installation

The Lo-Carbon VA150 range is suitable for installation in panels, walls or windows using the kits available. Lo-Carbon fans are quick and simple to fit using reversible grommets and easy-wire terminals, and are suitable for wall or ceiling mounting at any angle.

150mm telescopic wall kits are available with a white or brown outside grille. The kit is supplied with a telescopic wall sleeve to fit walls 225-360mm thick. Hole diameter 152mm.

Window fitting kits are available for use with all Lo-Carbon 150mm models through single or double glazed windows up to 40mm thick. Hole diameter 152mm.

Models

Lo-Carbon VA150P (Shutter/Pullcord)

Ultra long life DC energy saving motor. Fitted with a motorised shutter. Controlled via pullcord On/Off switch.

Model VA150P Stock Ref 459123

Lo-Carbon VA150T (Shutter/Timer)

Ultra long life DC energy saving motor. Fitted with a motorised shutter.

Controlled via integral power supply with electronic adjustable overrun timer (5-30 minutes).

Model VA150T Stock Ref 459124

Lo-Carbon VA150HP (Shutter/Humidistat)

Ultra long life DC energy saving motor. Fitted with a motorised shutter. Controlled via integral power supply with pullcord override switch and adjustable humidity sensor (60-95% RH).

Model VA150HP Stock Ref 459125

Accessories

Model Wall Kit White Stock Ref 140902
 Model Wall Kit Brown Stock Ref 140903
 Model Window Kit Stock Ref 140901

Dimensions (mm)

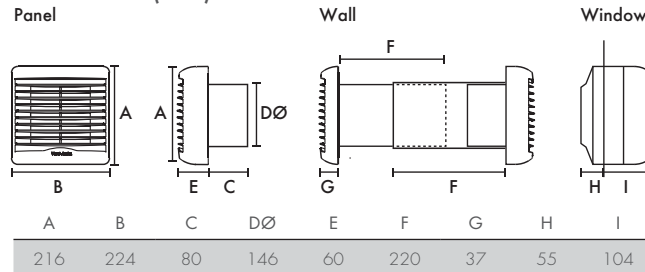

Weight 1.2kg

Performance Guide

Model	Setting	Extract Performance		Sound	Watts	SFP
		m³/h	l/s	dB(A)		(W/l/s)
Lo-Carbon VA150P/T/HP	Utility	160	46	33	7.5	0.16
	Kitchen	230	64	36	11.5	0.18

Lo-Carbon Silhouette 150

Features & Benefits

- Stylish ultra low profile grille
- Downstream airflow guide vanes for improved pressure development
- Ball bearing motors for vertical or horizontal application
- Wall kit design meets Building Regulations Approved Document F requirements
- 5 Year Motor Guarantee
- 1 of 2 speeds selectable at installation
- IPX4 rated
- Low Specific Fan Power
- Suitable for wall, ceiling and panel mounting



Slimline Lo-Carbon Kitchen Ventilation

The Lo-Carbon Silhouette 150 range is designed for modern living. With a profile of only 19mm on the kitchen models, Lo-Carbon Silhouette blends in with the wall surface to provide an unobtrusive installation.

Mounted in the centre of the fan, beneath the ultra slim profile grille, are the electronics, incorporating a humidistat (HT model) for detecting a change in internal humidity or an overrun timer option that is adjustable between 5 and 30 minutes.

FID performance of 65l/s, double insulated. Power consumption only 9 Watts.

Models

Lo-Carbon Silhouette 150B

150mm kitchen fan with indicator light and back draught shutter.

Model	Stock Ref
150B	441628

Lo-Carbon Silhouette 150T (Timer)

150mm kitchen fan with integral adjustable electronic overrun timer (5-30 minutes), indicator light which operates on manual override only and spring back draught shutter.

Model	Stock Ref
150T	441629

Lo-Carbon Silhouette 150HT (Humidistat/Timer)

150mm with integral adjustable auto humidity sensor from 60-90% RH and overrun timer, indicator light which operates on manual override only and back draught shutter. Datalogger as standard on all Lo-Carbon humidity controlled Silhouette fans.

Model	Stock Ref
150HT	441630

Accessories

Model	Stock Ref
Wall Kit White	140902
Wall Kit Brown	140903

Dimensions (mm)

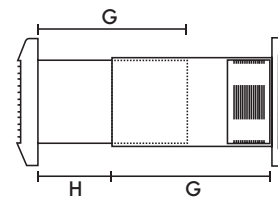
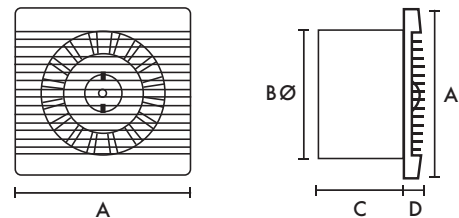

A	BØ	C	D	G	H
223	147	130	19	220	37

Weight 1.75kg

Performance Guide

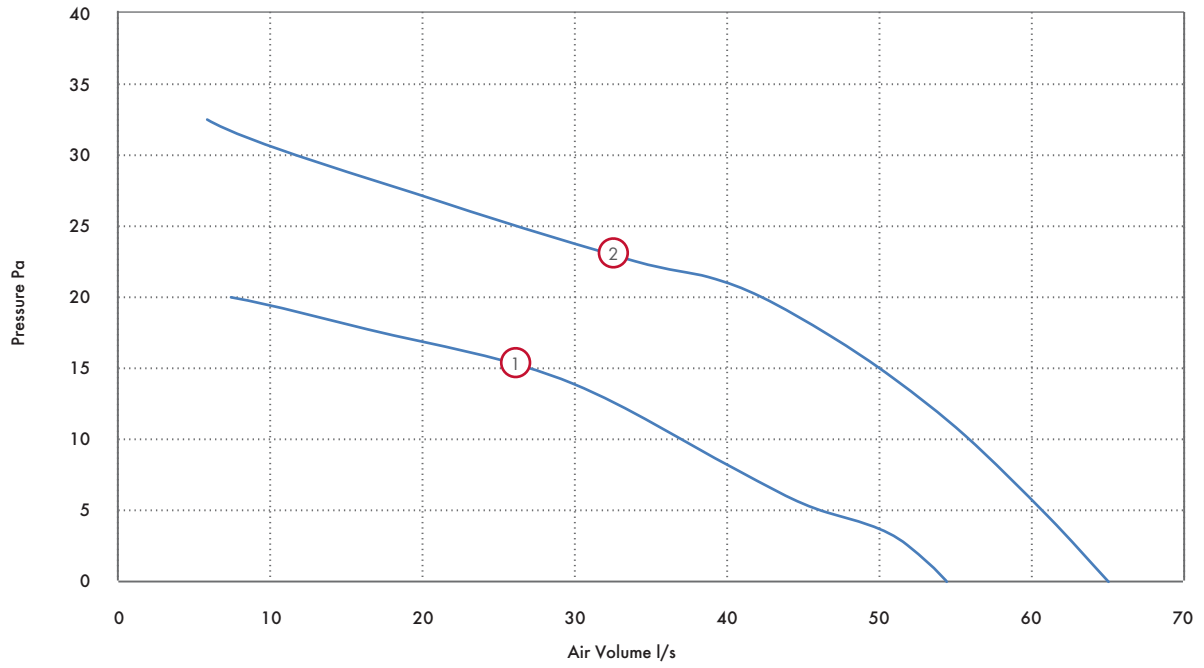

Model	Setting	Curve	Extract Performance			Sound dB(A)	SFP (W/l/s)
		Ref	m ³ /h	l/s	Watts	@ 3m	@ OPa
Lo-Carbon Silhouette 150B/T/HT	Utility Setting	1	200	55	6	35	0.11
	Kitchen Setting	2	234	65	9	43	0.14

Fixing hole diameter 152mmØ (when wall kit used)

Residential Fans



The UK's most comprehensive range of traditional fans for toilets, bathrooms, utility rooms and kitchens.

The NEW quieter Silent Fan



Now even more discrete than before at only 14dBA! The Vent-Axia Silent Fan, the quietest bathroom extract fan on the market.

The stylish design and silent performance means it is the ultimate in discrete bathroom ventilation. This means your bathroom can now be the relaxing environment you always wanted. At only 14 dB(A) our Silent Fan provides stylish and silent ventilation without compromising on performance. Need to hear it to believe it? Email demo@vent-axia.com to arrange a demonstration and hear for yourself just how quiet it is!

Meets current Building Regulations Approved Documents F & L.

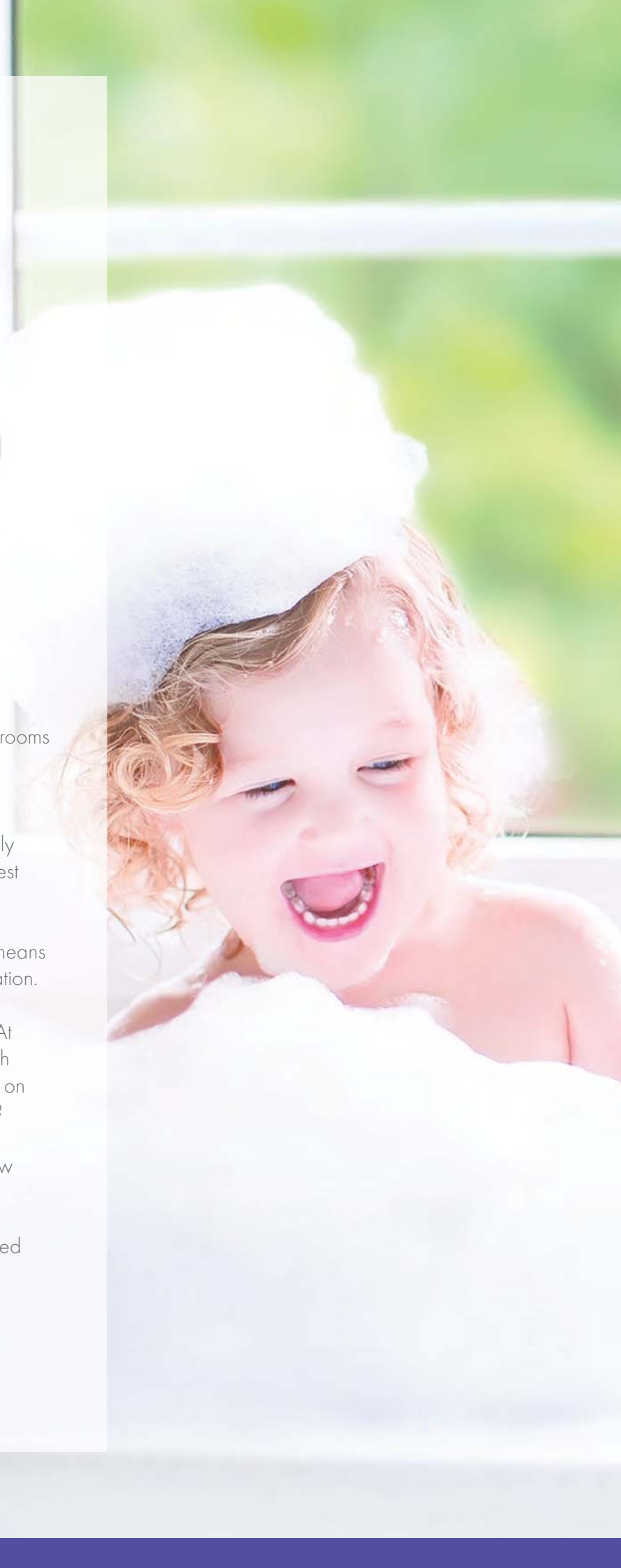
Vent-Axia



	VA100/SELV 12 Axial Bathroom/Toilet Fan	34-35
	Silhouette 100/SELV Axial Bathroom/Toilet Fan	36-37
	Silent Fan Axial Bathroom/Toilet Fan	38
	Silhouette 125 Axial Bathroom/Toilet Fan	39
	LuminAir Fan & Light Combination Unit	40-41
	LuminAir Fan & Light Ventilation Kit	42-43
	LuminAir Turbo Fan & Light Ventilation Kit	44-45
	Solo Plus Centrifugal Bathroom/Toilet Fan	46-47
	Solo Pro/SELV Centrifugal Bathroom/Toilet Fan	48-49
	VA140/150 Axial Kitchen Fan	50
	VA150 Window Mount Axial Kitchen Fan	51
	Silhouette 150 Axial Kitchen Fan	52-53
	Centrif Duo Centrifugal Kitchen & Utility Room Fan	54-55
	Centrif Duo Plus Centrifugal Kitchen & Utility Room Fan	56-57
	Freshvent Natural Vent	58-59
	Cookeer Hoods	60
	Pull-out System Hood	61
	Basics Range Basic, Simple, Solutions	62-63
	Eclipse Bathroom & Kitchen Axial Fan	64-65

VA 100/SELV

Features & Benefits

- Indication light
- Panel, ceiling, window or wall mounting
- Available with electric shutter
- Sensors and auto mode controllers save energy by switching the ventilation units on only when needed and when the room is occupied
- Adjustable overrun time option available (5-30 minutes)
- Meets current Building Regulations Approved Document F
- IPX4 rated - IPX7 rated (SELV)
- SELV Transformer to BS EN 60 742



Bathroom and Toilet Ventilation

The VA100 range from Vent-Axia is designed for domestic bathrooms and toilets. Available as window, wall or panel mounted and with options of shutter, timer or humidity controlled versions.

Designed in a clean white finish and suitable for ambient temperatures up to +40°C the unit is fitted with Standard Thermal Overload Protection (S.T.O.P.).

Safety Extra Low Voltage Fans (SELV)

Designed for areas where a fan has to be fitted over or within Zone 1 in a room containing a fixed bath or shower according to IEE wiring regulations (BS 7671), SELV models can be safely installed within the spray area. SELV models are rated IPX7. Control is by mains safety isolating transformer unit with SELV output, which is sited away from any source of spray and out of reach of a person using a fixed bath or shower.

Models

VA100LP (Pullcord)

Bathroom extract fan pullcord and indication light.

Model	Stock Ref
LP	251110

VA100 SELV

IPX7 rated fan with indication light, complete with remote wall mounted transformer.

Model	Stock Ref
SVL 12 (SELV)	258110

VA100LT (Timer)

Bathroom and toilet fan with adjustable electronic overrun timer and indication light which operates on the override only.

Model	Stock Ref
LT	251210

VA100 SELV (Shutter)

IPX7 rated fan with thermo-electric shutter and indication light, complete with remote wall mounted transformer.

Model	Stock Ref
SVX 12 (SELV)	258310

VA100XP/SELV XP (Shutter/Pullcord)

Bathroom fan with thermo-electric shutter, pullcord and indication light. SELV model IPX7 rated and complete with wall mounted transformer.

Model	Stock Ref
XP	251310
SVXP 12 (SELV)	258310BD025

VA100XT/SELV XT (Timer/Shutter)

Bathroom fan with integral adjustable overrun timer, thermo-electric shutter and indication light which operates on override only. SELV model IPX7 rated and complete with wall mounted transformer.

Model	Stock Ref
XT	251410
SVXT 12 (SELV)	258410

VA100LHP/SELV LHP (Humidity)

Bathroom fan with integral humidity sensor, pullcord override, and indication light which operates on manual override only. SELV model IPX7 rated and complete with wall mounted transformer.

Model	Stock Ref
LHP	251610
SVLHP 12 (SELV)	258112

VA100XHP/SELV XHP (Shutter/Humidity)

Bathroom fan with integral humidity sensor, thermo-electric shutter, pullcord override, and indication light which operates on manual override only. SELV model IPX7 rated and complete with wall mounted transformer.

Model	Stock Ref
XHP	251710
SVXHP 12 (SELV)	258312

VA100XHT/SELV XHT (Shutter/Humidity/Timer)

Bathroom fan with integral humidity sensor and adjustable overrun timer, thermo-electric shutter and indication light which operates on manual override only. SELV model IPX7 rated and complete with wall mounted transformer.

Model	Stock Ref
XHT	251510
SVXHT	258512

Accessories

Model	Stock Ref
Window Kit	254101
Wall Kit White	254102
Wall Kit Brown	254100
Anti-Tamper Window Kit	443234

Dimensions (mm)

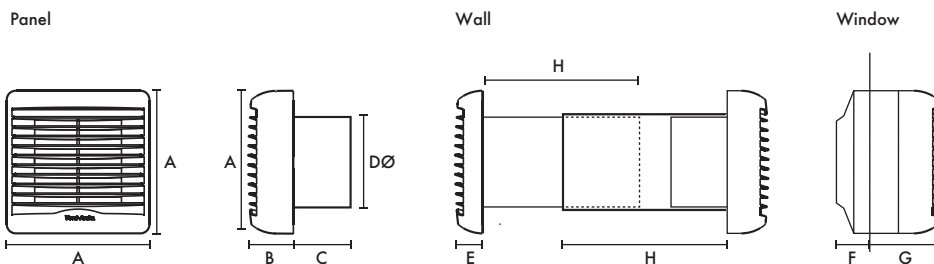

A	B	C	DØ	E	F	G	H
146	47	53	98	31	31	74	200

Weight 0.55kg

Fixing hole diameter 105mmØ (Panel & Window), 117mmØ (Wall). Transformer (WxHxD) 147x86x65.

Performance Guide - Panel Models

Extract performance

Model	m³/h	l/s	Watts	Sound dB(A) @ 3m
VA100LP	107	30	13	36
VA100LT	107	30	15	36
VA100XP	107	30	15	36
VA100XT	107	30	18	36
VA100LHP	107	30	16	36
VA100XHP	107	30	18	36
VA100XHT	107	30	18	36
VA100SVL	83	23	16	36
VA100SVX	83	23	18	36
VA100SVXT/XHP/XHT/XP	83	23	20	36
VA100SVLHP	83	23	18	36

Silhouette 100/SELV

Features & Benefits

- 17mm stylish ultra low profile grille
- Downstream airflow guide vanes for improved pressure development
- Designed for vertical or horizontal application
- Indication light (except B model)
- Fan IPX4 rated - IPX7 rated (SELV)
- Suitable for wall, ceiling, panel and window mounting
- Meets current Building Regulations Approved Document F
- SELV transformer to BSEN 60742



Slimline Bathroom Ventilation

With a slim profile of only 17mm, Silhouette blends in with the wall surface to provide an unobtrusive installation. Silhouette has a FID performance of 21 l/s. Silhouette can be ceiling/panel mounted and connected to an appropriate duct run to the outside.



Safety Extra Low Voltage (SELV) Fans

Safety Extra Low Voltage (SELV) is designed for areas where a fan has to be fitted within zone 1 in a room containing a fixed bath or shower according to IEE wiring regulations. The Silhouette SELV model can be safely installed within the spray area. SELV models are rated IPX7, control is by a mains safety isolating transformer with 12V DC SELV output, which is sited away from any source of spray and out of reach of a person using a fixed bath or shower.

Models

Silhouette 100B/SELV B

Single speed 100mm bathroom/toilet fan with back draught shutter. Indication light on SELV model only.

Model	Stock Ref
B	454055
SVB (SELV)	439974

Silhouette 100T/SELV T (Timer)

Single speed 100mm bathroom/toilet fan with integral adjustable electronic overrun timer (5-30 minutes), indication light and back draught shutter.

Model	Stock Ref
T	454056
ST (SELV)	439975

Silhouette 100HT (Humidity/Timer)

Single speed 100mm bathroom/toilet fan with integral adjustable auto humidity sensor from 60-90% RH, fixed 15 minute overrun timer option via jump switch, indication light and back draught shutter.

Model	Stock Ref
HT	454057

Silhouette 100 SELV SVH (Humidity)

Single speed 100mm bathroom/toilet fan with integral adjustable auto humidity sensor from 60-90% RH, indication light and back draught shutter.

Model	Stock Ref
SVH (SELV)	439976

Silhouette 100TM (PIR/Timer)

Single speed 100mm bathroom/toilet fan. Integral PIR operated model, (presence detector) with adjustable electronic overrun timer (5-30 minutes) indication light and back draught shutter.

Model	Stock Ref
TM	454058

Accessories

Model	Stock Ref
Wall Kit White	254102
Wall Kit Brown	254100
Window kit	442947

Dimensions (mm)

Panel

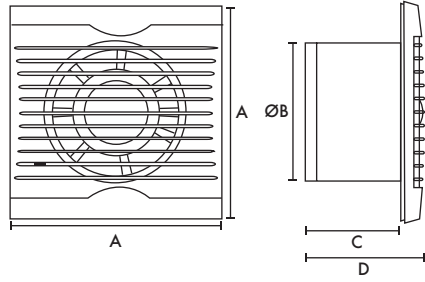

Wall Kit

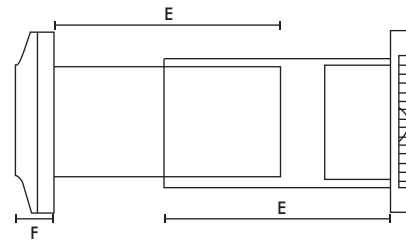

A	BØ	C	D	E	F
160	99	80	97	200	32

Transformer (W X H X D) 147 X 86 X 65

Weight 0.6kg

Fixing hole diameter 105mmØ (Panel & Window), 117mmØ (Wall)

Performance Guide

Model	Extract Performance - FID			Sound dB(A)
	m ³ /h	l/s	Watts	@ 3m
Silhouette 100B/T/H/TM	75	21	14	30
Silhouette 100SVB/SVT/SVH	75	21	15	30

Silent Fan

Features & Benefits

- Only 14dB(A)
- Silent intermittent bathroom fan with two speeds selectable at installation
- Stylish discrete design
- Back draught shutters included (remove when ceiling mounting)
- High efficiency motor
- 2 year guarantee
- IP24 rated
- Standard thermal overload protection on motor
- Suitable for wall, ceiling, window and panel mounting
- Meets current Building Regulations Approved Document F and L



the **ELECTRICAL**
industry awards
WINNER 2012



Silent Fan Axial Bathroom/Toilet Fan

The quietest bathroom fan on the market. The VASF100 provides stylish and silent ventilation without compromising on performance.

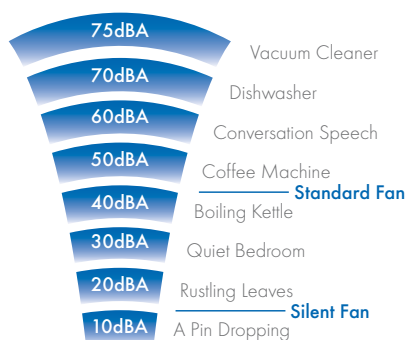

Dimensions (mm)

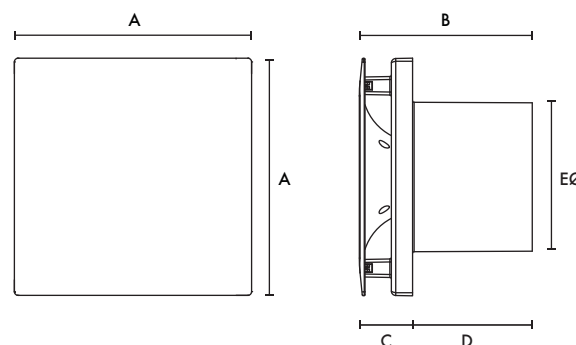

A	B	C	D	EØ
159	117	37	80	99

Weight 0.7kg

Models

VASF100B

1 of 2 speeds selectable at installation. 100mm bathroom / toilet fan with back draught shutter.

Model	Stock Ref
VASF100 B	446658

VASF100T (Timer)

1 of 2 speeds selectable at installation. 100mm bathroom / toilet fan with back draught shutter. Overrun timer adjustable between 5 and 30 minutes.

Model	Stock Ref
VASF100 T	446659

Accessories

Model	Stock Ref
Window Kit	442947
Wall Kit White	254102
Wall Kit Brown	254100

Performance Guide

Model	l/s	Watts	Sound dB(A) @ 3m
VASF100 - low speed	15	3.2	14
VASF100 - high speed	21	5.0	28

Silhouette 125

Features & Benefits

- 18mm stylish ultra low profile grille
- Downstream airflow guide vanes for improved pressure development
- Designed for vertical or horizontal application
- Modern aesthetic with indication light
- Fan IPX4 rated
- Suitable for wall, ceiling and panel mounting



Slimline Bathroom Ventilation

With a slim profile of only 18mm, Silhouette blends in with the wall surface to provide an unobtrusive installation. Silhouette has a FID performance of 160m³/h. Silhouette can be wall, ceiling or panel mounted and connected to an appropriate duct run to the outside.



Models

Silhouette 125B

Single speed 125mm, bathroom/toilet fan with indication light and back draught shutter.

Model **B** Stock Ref **445161**

Silhouette 125T (Timer)

Single speed 125mm bathroom/toilet fan with integral adjustable electronic overrun timer (5-30 minutes), indication light and back draught shutter.

Model **T** Stock Ref **445162**

Silhouette 125H (Humidistat)

Single speed 125mm bathroom/toilet fan with integral adjustable auto humidity sensor from 60-90% RH, indication light and back draught shutter.

Model **H** Stock Ref **445163**

Accessories



Model **Wall Kit** Stock Ref **445226**

Dimensions (mm)

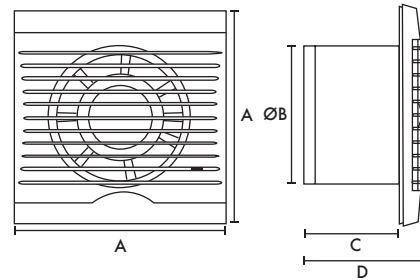

A	B Ø	C	D
187	125	131	149

Performance Guide

Model	Extract Performance - FID			Sound dB(A)
	m ³ /h	l/s	Watts	@ 3m
Silhouette 125B/T/H	160	45	20	40

LuminAir Fan & Light Combination Unit

Features & Benefits

- The original fan and light combination
- IPX7 rated
- Suitable for shower enclosures and wet areas - can be used within reach of a person using a bath or shower
- Safety extra low voltage (SELV)
- Easy installation
- White, Gold and Chrome bezels available



Safety Extra Low Voltage

The revolutionary Vent-Axia LuminAir Safety Extra Low Voltage fan and light in a single ceiling mounted fitting.

The IPX7 unit is installed directly over a shower in complete safety. Vent-Axia LuminAir extracts moisture and humidity at source, preventing damaging condensation from spreading. At the same time it bathes the shower enclosure in a rich soft light - bringing any dark shower to life. Ideal for all types of bathroom and shower applications, and is particularly suitable for bedsit and en-suite shower installations.

Designed for mounting in a wide variety of ceiling thicknesses. The safety isolating transformer to BS EN 60742 is mounted in a purpose made enclosure that can be wall mounted or sited in the loft, and is designed to accept mini trunking (LuminAir L transformer - IP20 - loft mounted).

LuminAir has a 20 Watt 40° spread, preformed Dichroic Multi-Mirror™ lamp, to give a pool of soft warm light. The lamp has a long life and is simple to change.

Separate lighting transformer also supplied.

Models

LuminAir L (Switch Live)

Provides simultaneous fan and light operation from the bathroom light switch.

Model	Stock Ref
L	188110

LuminAir T (Timer)

Switches the fan On with the light. When the light is switched Off, the fan continues to run for an adjustable set period to meet the Building Regulations for internal bathrooms.

Model	Stock Ref
T	188210

LuminAir H (Humidistat)

Combines a light activated by the bathroom light switch and an Ecotronic Humidity Sensor which will switch the fan On whenever the humidity level warrants.

Model	Stock Ref
H	188610

Supply to the LuminAir transformer 220-240V/ 1/50Hz.

Output to LuminAir 12V SELV/1/50Hz. Safety isolating transformers conform to BS EN 60742.

Accessories

Model	Stock Ref
Optional Bezel Chrome	452044
Optional Bezel Gold	452045

LuminAir Vent Light Safety Extra Low Voltage Duct Air Inlet

LuminAir Vent Light is for upgrading existing extract systems or to provide multiple extract points to a central fan. The Vent Light consists of a LuminAir Safety Extra Low Voltage (SELV) light with white ceiling bezel and 90° bend suitable for use with remote extract fan using 100mm duct. On/Off operation is via the bathroom light switch. Gold and chrome bezels are available as accessories.

Model	Stock Ref
White	453395

Installation Example

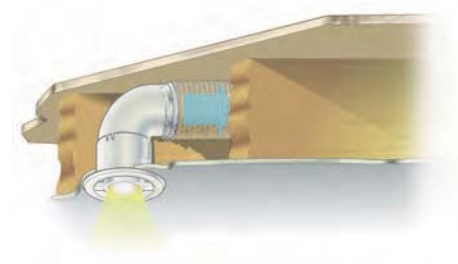

Dimensions (mm)

Vent Light

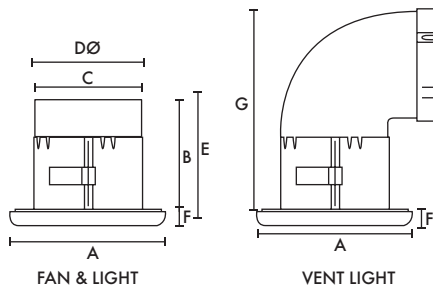

Humidity Sensor

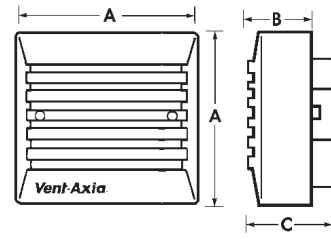

Model	A	B	C	DØ	E	F	G
LuminAir	150	140	98	103	150	10	180
Transformer (Fan)	147	86	65				
Transformer (Light)	110	35	25				
Humidity Sensor	87	33	47				

Fixing hole diameter 110mm

Performance

Model	Extract performance - FID		Max Watts		Sound dB(A)	Amps
	m ³ /h	l/s	Fan	Lamp	@ 3m	@ 240V
LuminAir L	110	31	20	20	35	0.2
LuminAir T	110	31	22	20	35	0.2
LuminAir H	110	31	24	20	35	0.2

LuminAir Fan & Light Ventilation Kit

Features & Benefits

- Unique fan and light combination
- IPX7 rated inlet assembly
- Suitable for shower enclosures and wet areas - can be used within reach of a person using a bath or shower
- Safety extra low voltage (SELV) fan and lamp
- Easy installation
- White, Gold and Chrome bezels available



SELV Fan & Light Combination

LuminAir is also available in the form of a ventilation kit which, in addition to the fan and light combination, comes with a 90° bend, 3M of flexible ducting, wall grille and cable ties. The IPX7 unit is installed directly over a shower in complete safety.

Vent-Axia LuminAir extracts moisture and humidity at source, preventing damaging condensation from spreading. At the same time it bathes the shower enclosure in a rich soft light - bringing any dark shower to life. Ideal for all types of bathroom and shower applications, and is particularly suitable for bedsit and en-suite shower installations. LuminAir has a 20 Watt 40° spread, preformed Dichroic Multi-Mirror™ lamp, to give a pool of soft warm light. The lamp has a long life and is simple to change.

Separate lighting transformer also supplied.

Models

LuminAir L, T or H SELV fan and light, choice of bezel, 90° bend, 3m of flex-duct, wall grille and cable ties.

LuminAir Shower Ventilation Kit L

(Switch Live)

Provides simultaneous fan and light operation from the bathroom light switch.

Stock Ref

453410 (White)

LuminAir Shower Ventilation Kit T

(Timer)

Switches the fan On with the light. When the light is switched Off, the fan continues to run for an adjustable set period.

Stock Ref

453413 (White)

LuminAir Shower Ventilation Kit H (Humidistat)

Combines a light activated by the bathroom light switch and an Ecotronic Humidistat Sensor which will switch the fan On whenever the humidity level warrants.

Stock Ref

453416 (White)

Accessories

Optional Bezels

Stock Ref

452044 (Chrome)

452045 (Gold)

Installation Example



Dimensions (mm)

Vent Light

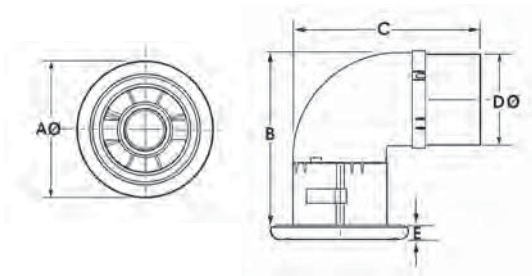

Humidity Sensor

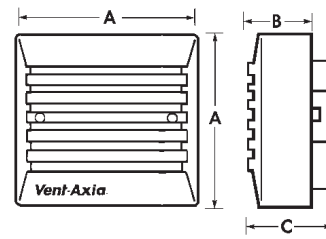

Model	AØ	B	C	DØ	E
Vent Light	150	180	139	98	10
Humidity Sensor	87	33	47		

Fixing hole diameter 110mm

Transformer Dimensions (mm)

Model	Length	Height	Depth
Transformer (Fan)	147	86	65
Transformer (Light)	110	35	25

Performance

Model	Extract Performance - FID		Watts		Sound dB(A)	Amps
	m ³ /h	l/s	Fan	Lamp	@ 3m	@ 240V
LuminAir Ventilation Kit L/T/H	110	31	20	20	35	0.2

LuminAir Turbo Fan & Light Ventilation Kit

Features & Benefits

- Unique fan and light combination
- IPX7 rated inlet assembly
- Suitable for shower enclosures and wet areas - can be used within reach of a person using a bath or shower
- Safety extra low voltage (SELV) lamp
- Easy installation
- White, Gold and Chrome bezels available



High Performance Fan & Light Combination

LuminAir is also available in the form of a ventilation kit. The IPX7 unit is installed directly over a shower in complete safety.

Vent-Axia LuminAir extracts moisture and humidity at source, preventing damaging condensation from spreading. At the same time it bathes the shower enclosure in a rich soft light - bringing any dark shower to life. Ideal for all types of bathroom and shower applications, and is particularly suitable for bedsit and en-suite shower installations. LuminAir has a 20 Watt 40° spread, preformed Dichroic Multi-Mirror™ lamp, to give a pool of soft warm light. The lamp has a long life and is simple to change.

Models

For applications where a more powerful system is required, the kit comprises a luminair turbo L or T mains fan and SELV light, choice of bezel, 90° bend, 6 metres of flexible duct, quick fix wall grille and four cable ties. Meets Building Regulations approved Document F performance assuming ductwork provided is fully extended and one 90° bend.

LuminAir Turbo SKL (Switch Live)

Provides simultaneous On and Off operation of the fan and light switch from the bathroom light switch.

Model	Stock Ref
SKL White	453419

LuminAir Turbo SKT (Timer)

Switches the fan On with the light switch. When the light is switched Off, the fan continues to run for an adjustable fixed period to meet the Building Regulations for internal bathrooms.

Model	Stock Ref
SKT White	453422

Accessories

Model	Stock Ref
Optional Bezel Chrome	452044
Optional Bezel Gold	452045

Installation Example



Dimensions (mm) Vent Light and Bend

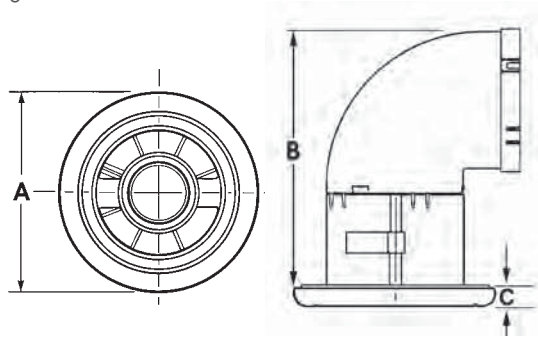

Turbo Fan

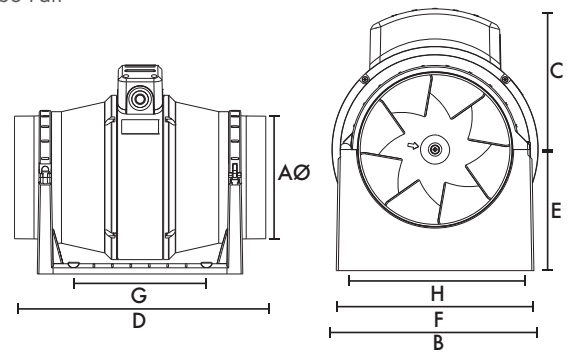

Model	AØ	B	C	D	E	F	G	H
Vent Light	150	180	10					
Turbo Fan	97	178	124	298	96	168	120	153.5

Ceiling Fixing hole diameter 110mm

Transformer Dimensions (mm)

Model	Length	Width	Lid	Base
Transformer T&H	175	90	55	30
Transformer L	83	76	70	61
Humidity Sensor	87	87	33	

Fixing Hole diameter 110mm

Performance

Model	Extract Performance - FID		Watts		Sound dB(A)	Amps
	m ³ /h	l/s	Fan	Lamp	@ 3m	@ 240V
SKL/SKT	160	52	8	20	23	0.3

Solo Plus

Features & Benefits

- Filterless as standard - innovative impeller design means no need for a filter
- Meets current Building Regulations Approved Documents F & L requirements for domestic bathrooms and toilets
- IPX4 rated
- Flush or surface mountable
- Adjustable rear or side exit spigot
- Extremely low sound levels
- Suitable for wall, ceiling and panel mounting



Bathroom and Toilet Ventilation

The Solo Plus range from Vent-Axia has been specially designed for through the wall and ducted applications, suitable for internal bathrooms, toilets and other small rooms. Finished in white, the Solo Plus can be flush or surface mounted, with a 100mm circular spigot for rear entry or connecting to a vertical ducting system. The spigot can also be adjusted for side ways exhaust enabling recessed ceiling installations within limited ceiling voids. The powerful centrifugal impeller allows for installations with longer duct runs using 100mm ducting, whilst still achieving 15 l/s as required by Document F of the current Building Regulations.

Continuous running products, such as the Solo Plus installed in all wet areas of a dwelling are classed as a wholehouse ventilation system and therefore, only needs to move the amount of air as laid down in table 1.1b of Document F.

The Solo Plus has a choice of two boost/override motor speeds set at installation, medium (17l/s) or high (22l/s), with an optional constant trickle speed (9l/s), also selectable at installation except in the P model. Depending on the model, the fan will switch from trickle (if selected) to boost (medium or high) via the pullcord/light switch/humidity sensor/PIR.

All models can be wall, panel or ceiling mounted and can be connected to either circular, rectangular or Vent-Axia's flat ducting. Enclosure of the electrical components is manufactured from flame retardant grade material.

Supply voltage 220-240V/1/50Hz.

Models

Solo Plus P (Pullcord)

Flush or surface mountable. Control by pullcord single speed; 1 of the 3 speeds selectable at installation.

Model	Stock Ref
P	427477

Solo Plus T (Timer)

Flush or surface mountable. Constant trickle option. 2 Speed. Adjustable timer overrun. Delay on timer option.

Model	Stock Ref
T	427478

Solo Plus HT (Humidistat/Timer)

Flush or surface mountable. Humidity controlled fan with override pullcord. Constant trickle option. Adjustable timer overrun. Delay on timer option. Adjustable humidity sensor.

Model	Stock Ref
HT	427479

Solo Plus TM (Timer/PIR)

Flush or surface mountable. Control by integral PIR detector. Constant trickle option. 2 Speed.

Model	Stock Ref
TM	427480

Accessories

Solo Plus Bezel

Used when flush mounting, reduces the need to make good.

Model	Stock Ref
Bezel	404106

Model	Stock Ref
Wall Kit White	254102
Wall Kit Brown	254100

Filter pack (1 per pack)

The design of the Solo Plus means that it does not need a filter. However, if you are going to install the product in a heavily greasy environment, you may want to protect the product by fitting a filter.

Model	Stock Ref
Filter pack	449265

Dimensions (mm)

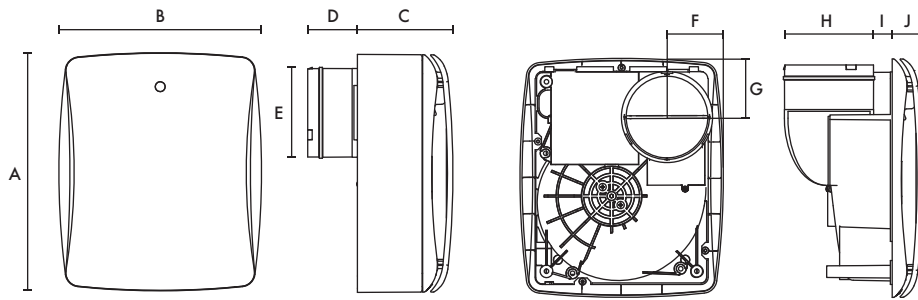

A	B	C	D	EØ	F	G	H	I	J
263	224	106	55	98	62	65	98	21	34

Performance Guide

Model	Extract Performance l/s (m ³ /h) - FID			Watts			dB(A) @ 3m		
	Max Boost	Min Boost	Trickle	Max Boost	Min Boost	Trickle	Max Boost	Min Boost	Trickle
Solo Plus P/T/HT/TM	22 (80)	17 (61)	9 (32)	17.1	10.9	6.3	34.5	24	11.5

Tested at 240VAC @ 50Hz

Solo Pro/SELV

Features & Benefits

- 100mm high performance centrifugal extract fan for internal bathrooms, toilets and other small rooms
- Updated design
- Now even quieter at just 30dB(A)
- Extract performance 24l/s
- Single speed and overrun timer models
- Suitable for wall, ceiling, panel and window mounting
- SELV models suitable for installation over or within reach of a shower or bath
- Suitable for use with flat ducting
- IPX4 rated - IPX7 rated (SELV)
- Transformer complies with BS EN 60742



High Performance Ventilation

The new Solo Pro is a new and improved version of our trusted Solo model. With improved aesthetics, sound and installation it has been specifically designed for effective ducted ventilation of internal bathrooms, toilets and other small rooms. Finished in White, the new Solo Pro range can be used with 100mm diameter smooth bore duct in straight runs equal to 50m, yet still meets the minimum 15l/s required by the current Building Regulations Document F for ventilation of bathrooms. Solo Pro can also be used with flat ducting for shorter concealed runs.

Models are available for surface or recessed mounting directly into standard 100mm diameter ducting. Suitable for panel, wall and ceiling installations and windows up to 25mm thick. For high rise or coastal applications, install through the wall with a Vent Cowl (Stock Ref 561403).

Safety Extra Low Voltage

SELV models are designed for areas where a fan has to be fitted within zone 1 in a room containing a fixed bath or shower according to IEE wiring regulations. The Solo SELV models can be safely installed within the spray area. The SELV models are rated IPX7, control is by a mains safety isolating transformer with 12V DC SELV output, which is sited away from any source of spray and out of reach of a person using a fixed bath or shower.

The safety isolating transformer, to BS EN 60742, is mounted in a purpose made enclosure. The enclosure can be wall mounted or sited in the loft. The enclosure will accept mini trunking.

Electrical

Rear 20mm conduit entry for recessed wiring and side entry grommet for surface wiring.

Supply voltage to transformer/controller 220-240V/1/50Hz. Output to fan 12V SELV/ 1/50Hz.

To meet IEE Regulations, timer models should be isolated using a 3 pole isolator.

Model	Stock Ref
3 pole isolator	563518

Models

Solo Pro P/SELV SVP (Pullcord)

Control by pullcord or from light/remote switch or sensor. Back draught shutter. SELV model comes with mains transformer with 12V SELV output.

Model	Stock Ref
P	409159
SVP (SELV)	409163

Solo Pro T/SELV T (Timer)

Control by light/remote switch. Overrun timer variable from 5 to 30 minutes. Back draught shutter. SELV model comes with mains transformer with 12V SELV output.

Model	Stock Ref
T	409160
SVT (SELV)	409164

Solo Pro HTP/SELV SVHTP (Humidity and Timer)

Humidity controlled with pullcord override. 17 min overrun timer. Back draught shutter. SELV model comes with mains transformer with 12V SELV output.

Model	Stock Ref
HTP	409161
SVHTP (SELV)	409165

Solo Pro TM (Timer/PIR)

Controlled by separate PIR sensor supplied with fan. Built in overrun timer, variable from 5 to 30 minutes, switches fan Off.

Model Stock Ref
 TM 409162

Accessories

Model Stock Ref
 Wall Kit White 254102
 Wall Kit Brown 254100
 Window Kit 11461685

Dimensions (mm)

Wall

Front view

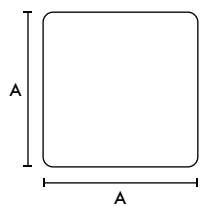

Rear view

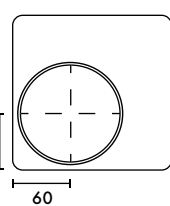

Side view

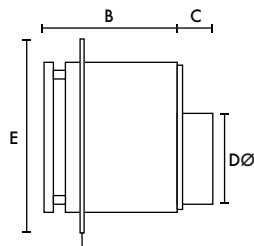

Position of flange for recessed mounting

Duct hole diameter 115mmØ

Window

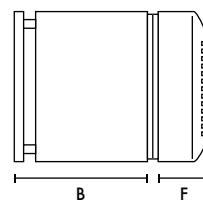

Window fixing hole Ø113mm

Model	A	B	C	DØ	E	F
Solo Pro/SELV12 P/T/HTP/TM	154	119	25	100	195	57.5

Transformer (W x H x D) 175 x 90 x 85

Performance Guide

Model	Extract Performance		Max Watts	dB(A) @ 3m	Amps @ 240V
	m ³ /h	l/s			
Solo Pro SELV12/T/HP	80	22	19	30	0.26
Solo Pro P/T/HTP/TM	80	22	17	30	0.15

VA140/150

Features & Benefits

- VA140/150 Panel models
- 2 Year Guarantee
- Thermo electric shutters to prevent back draughts
- Meets current Building Regulations Approved Document F
- IP44 rated
- Suitable for wall, ceiling, panel and window mounting



Kitchen ventilation

VA140/150 Panel models are designed to alleviate the everyday problems that condensation and household odours may cause. Effectively extracts odours and moisture laden air from kitchens giving a healthy and fresh environment.

Building Regulations

Specifically sized to meet the current Building Regulation requirements for powered extract ventilation in domestic kitchens. Control facility fitted as standard. The VA140/150 range is fitted with internal louvres conforming to the latest international safety standards.

Please contact our Customer Service Department for exposed site application.

Models

VA140/150KP (Pullcord)

Single speed kitchen extract fan with On/Off pullcord.

Model **Stock Ref**
 KP **140120**

VA140/150KT (Timer)

Single speed kitchen extract fan with adjustable overrun timer (3-30 minutes).

Model **Stock Ref**
 KT **140220**

VA140/150KHP (Humidistat)

Single speed humidity-controlled kitchen extract fan with full speed pullcord override. Humidity adjustment 62-82%RH.

Model **Stock Ref**
 KHP **140320**

VA140/150KHT (Timer/Humidistat)

Humidity controlled kitchen extract fan with adjustable overrun timer (3-30 minutes). Humidity adjustment 62-82% RH.

Model **Stock Ref**
 KHT **140420**

VA140/150VS (Variable Speed)

Variable speed kitchen extract with a built in adjustable speed controller, which can reduce the speed to 40% of its maximum performance.

Model **Stock Ref**
 VS **458915**

Accessories

Model **Stock Ref**
 Wall Kit White **140902**
 Wall Kit Brown **140903**
 Window Kit **140901**

Dimensions (mm)

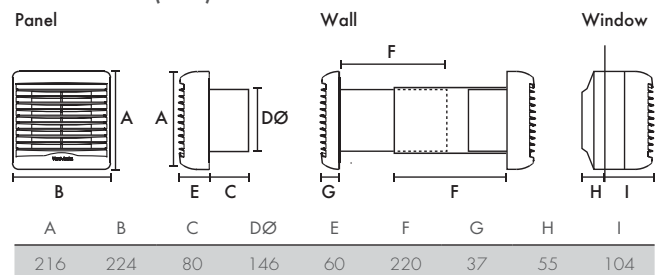

Weight 1.75kg

Fixing hole Ø 152mm (Panel), Ø 160mm (Window), Ø 152mm (Wall)

Performance Guide

Model	Shutter Actuator	Extract Performance FID		Sound	
		m³/h	l/s	Watts	dB(A) @ 3m
VA140/150KP	Pullcord	245	68	18.8	36
VA140/150KT/KHP/KHT	Instant	245	68	18.8	36
VA140/150VS	Pullcord	100 - 245	28 - 68	18.8	36

VA150

Features & Benefits

- Complete with window kit
- 2 Year Guarantee
- Meets current Building Regulations Approved Document F
- Integrated, concealed shutter
- Natural trickle vent facility when unpowered



Kitchen ventilation

VA150 Window models are designed to alleviate the everyday problems that condensation and household odours may cause. Effectively extracts odours and moisture laden air from kitchens giving a healthy and fresh environment.

Shutter

The louvre shutter on the VA150 is concealed behind the interior grille. Operates automatically when the fan is switched On. Natural trickle vent facility (unpowered) available on all models.

Building Regulations

The VA150 Range is specifically sized to meet the current Building Regulation requirements for powered extract ventilation in domestic kitchens. The VA150 range is fitted with internal and external louvres conforming to the latest international safety standards.

Motor

Maintenance free, sealed for life ball bearings in the purpose made electric motor, economical and quiet running. Double insulated appliance. Supply voltage 220-240V/1/50Hz.

Models

VA150P (Pullcord)

Specifically designed for domestic use in kitchens and utility rooms, the VA150P is a single speed 150mm (6") extract ventilation unit for windows. Fan and shutter operated by integral pullcord. (window kit supplied). IP24 Rated. Colour: white.

Model P **Stock Ref** 152110

VA150A

A single speed 150mm (6") extract fan with instant opening/closing shutter operated by remote switch. Suitable for installation in bathroom or kitchen. (Window kit supplied). IP44 Rated. Colour: white.

Model A **Stock Ref** 153110

Dimensions (mm)

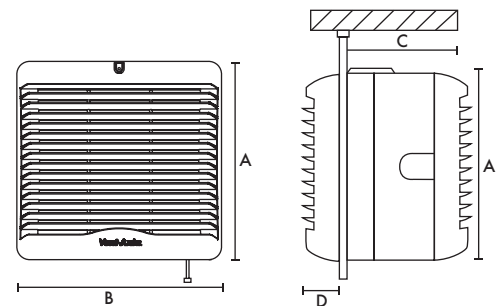

A	B	C	D
216	224	130	55

Weight 2.5kg

Window fixing hole \varnothing 184mm

Performance Guide

Model	Shutter Attenuator	Extract Performance - FID		Watts	Sound dB(A) @ 3m
		m ³ /h	l/s		
VA150P/A	Pullcord/Instant	220	60	19	37

Silhouette 150

Features & Benefits

- Stylish ultra low profile grille
- Downstream airflow guide vanes for improved pressure development
- Modern aesthetics
- Electric back draught shutters
- IPX4 rated
- Suitable for wall, ceiling and panel mounting
- Meets current Building Regulations Approved Document F



Slimline Kitchen Ventilation

The Vent-Axia Silhouette range is designed for modern living. With a profile of only 19mm on the kitchen models, Silhouette blends in with the wall surface to provide an unobtrusive installation.

Mounted in the centre of the fan, beneath the ultra slim profile grille, are the electronics, incorporating a humidistat for detecting a change in internal humidity or an overrun timer option that is adjustable between 5 and 30 minutes.

Models

Slim profile only 19mm. FID performance of 241 m³/h, double insulated.

Silhouette 150X

Single speed 150mm kitchen fan with electric back draught shutter.

Model	Stock Ref
X	454059

Silhouette 150XT

Single speed 150mm kitchen fan with integral adjustable electronic overrun timer (5-30 minutes), indication light and electric back draught shutter.

Model	Stock Ref
XT	454060

Silhouette 150XH

Single speed 150mm with integral adjustable auto humidity sensor from 60-90% RH, indication light and electric back draught shutter. Switch live for override by remote switch/light switch.

Model	Stock Ref
XH	454061

Accessories

Model	Stock Ref
Wall Kit White	140902
Wall Kit Brown	140903

Dimensions (mm)

Panel

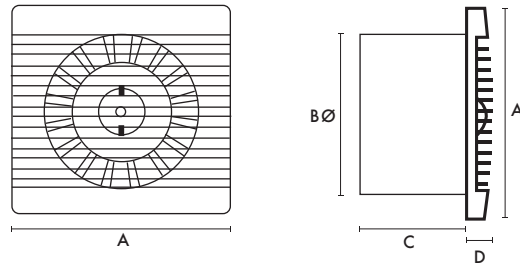

Wall

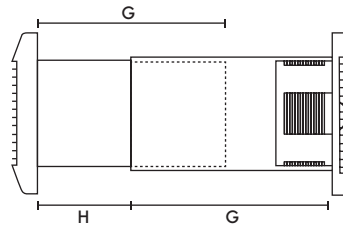

fixing hole diameter 152mmø (when wall kit used)

A	B	C	D	G	H
223	147	111	19	220	37

Weight 1.75kg

Performance

Model	Extract Performance - FID			Sound dB(A)
	m ³ /h	l/s	Watts	@ 3m
Silhouette 150X/XT/XH	241	67	20	43

Centrif Duo

Features & Benefits

- 100mm circular spigot for speedy installation
- Humidity sensing model for automatic operation
- Suitable for both kitchen and utility rooms
- Includes washable grease filter and removable grille assembly for easy cleaning
- Speed set at installation
- Meets current Building Regulations Approved Document F
- Timer model for internal rooms
- Surface mounted



Kitchen and Utility Ventilation

The Centrif Duo range is a series of 100mm centrifugal extract fans for the domestic environment. The range is designed to provide extraction levels that comply with Building Regulation requirements, with special humidity sensing variants for local authority use.

Motor

The motor features greased-for-life ball bearings which allow the fan to be installed at any angle. Insulation is Class E. Double insulated appliance. Supply voltage 220-240V/1/50Hz.

Fast installation

The Centrif Duo has a 100mm circular spigot. The Flush mounting kit enables the spigot to be converted to a side outlet. The spigot also encloses a built-in, spring operated back draught shutter. The Centrif Duo Range can be wall mounted using a telescopic wall fitting kit available as an accessory (requires a 115mm diameter hole).

Humidistat control

Humidistat is selectable for either kitchen or utility speed separate to any other control to reduce nuisance noise. Boost operation by pullcord or switch live.

Models

Centrif Duo P (Pullcord)

Two speed kitchen extract fan with pullcord. Choice of two speeds for boost, set at installation.

Model	Stock Ref
P	256120

Centrif Duo T (Timer)

Two speed with adjustable timer between 5-30 minutes. Choice of two speeds for boost, set at installation.

Model	Stock Ref
T	256220

Centrif Duo DP (Two Speed)

Two speed and Off with pullcord or remote switch. Switches between Off, Low and one of the 2 Boost speeds.

Model	Stock Ref
DP	256320

Centrif Duo HTP (Humidity)

Intermittent on 1 of 2 speeds (Utility or Kitchen selectable at installation). Operation by integral humidity sensor or pullcord. Separate speeds selectable for humidistat and pullcord. Optional continuous trickle speed available at installation.

Model	Stock Ref
HTP	256420

Accessories

Flush Mounting Kit

Bezel, clips and 90° duct elbow reduces the need to make good.

Model	Stock Ref
Flush Mounting Kit	439256

Model	Stock Ref
Wall Kit White	254102
Wall Kit Brown	254100
Decoration Frame	442551

Dimensions (mm)

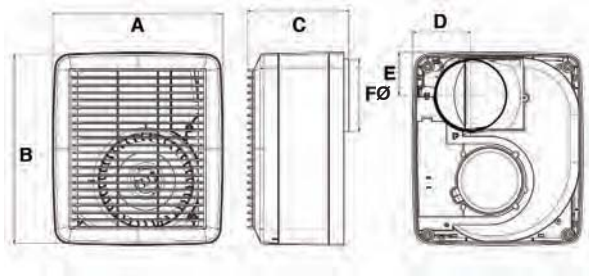

A	B	C	D	E	FØ
231	261	137	79	58	98

Weight 1.75kg

Performance

Model	Performance @ 0 pa						Power (W)			Sound dB(A) @ 3m			SEC Class
	High speed		Med speed		Low speed		Kitchen	Utility	Trickle	Kitchen	Utility	Trickle	
	m ³ /h	l/s	m ³ /h	l/s	m ³ /h	l/s							
Centrif Duo P/T	220	61	130	36	-	-	60	41	N/A	51.8	38	N/A	D
Centrif Duo DP/HTP	220	61	130	36	90	25	60	41	9	51.8	38	21.5	D

Centrif Duo Plus

Features & Benefits

- Meets current Building Regulations Approved Document F
- Optional filter available
- Easy installation
- Fan can be wall or ceiling mounted
- Suitable for both kitchen and utility rooms
- Constant trickle boost speed available on DP & HTP models
- IPX4 Rated



Ultra Quick Ventilation

Centrif Duo Plus is designed to provide extraction levels that comply with Building Regulations Approved Document requirements, with special humidity sensing variants for local authority use.

The Centrif Duo Plus is for kitchens and utility rooms and large bathrooms. Surface mounting directly into standard 100mm diameter ducting, through the wall or ceiling installation.

Fast Installation

The Centrif Duo Plus has a 100mm circular spigot. The Flush mounting kit enables the spigot to be converted to a side outlet.

The spigot also encloses a built-in, spring operated back draught shutter. The Centrif Duo Plus Range can be wall mounted using a telescopic wall fitting kit available as an accessory (requires a 115mm diameter hole). For ceiling applications the range is ducted either through a soffit outlet or roof cowl assembly. There is convenient access for wiring which accommodates surface or recessed installation.

Improved Humidistat Control

Humidistat is selectable for either kitchen or utility speed separate to any other control to reduce nuisance noise. Boost operation by pullcord or switch live.

Models

Centrif Duo Plus P (Pullcord)

Two speed kitchen extract fan with pullcord. Choice of two speeds for boost, set at installation.

Model	Stock Ref
P	431613

Centrif Duo Plus T (Timer)

Two speed with adjustable timer between 2-30 minutes. Choice of two speeds for boost, set at installation.

Model	Stock Ref
T	431614

Centrif Duo Plus DP (Two speed)

Two speed and Off with pullcord or remote switch. Switches between Off, low and one of the 2 boost speeds.

Model	Stock Ref
DP	431615

Centrif Duo Plus HTP (Humidity/ Timer/ Pullcord)

Intermittent on 1 of 2 speeds (Utility or Kitchen selectable at installation). Operation by integral humidity sensor or pullcord. Separate speeds selectable for humidistat and pullcord. Optional continuous trickle speed available at installation.

Model	Stock Ref
HTP	431616

Accessories

Flush Mounting Kit

Bezel, clips and 90° duct elbow reduces the need to make good.

Model	Stock Ref
Flush Mounting Kit	439256

Model	Stock Ref
Centrif Duo Plus Filter	439927
Wall Kit White	254102
Wall Kit Brown	254100
Decoration Frame	442551

Dimensions (mm)

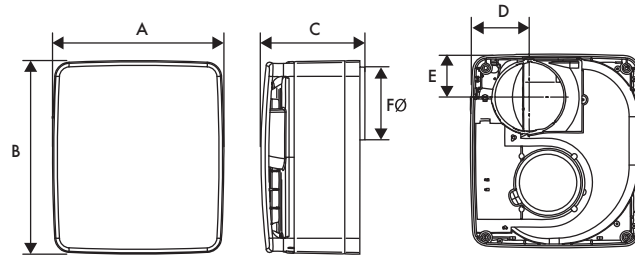

A	B	C	D	E	FØ
231	261	140	79	58	98

Weight 1.75kg

Performance Guide

Model	Performance @ 0 Pa						Power (W)			Sound dB(A) @3m			SEC Class
	High speed		Med speed		Low speed		Kitchen	Utility	Trickle	Kitchen	Utility	Trickle	
	m ³ /h	l/s	m ³ /h	l/s	m ³ /h	l/s							
Centrif Duo Plus P/T	220	61	130	36	-	-	60	41	N/A	51.8	38	N/A	D
Centrif Duo Plus DP/HTP	220	61	130	36	90	25	60	41	9	51.8	38	21.5	D

Freshvent

Features & Benefits

- Completely silent, all year round ventilation
- Complements existing ventilating fans
- Filtered, natural air without draughts
- Control of the indoor environment
- Helps prevent damaging condensation
- No energy consumption, no running costs



Natural Ventilation

Freshvent 100 is a range of passive ventilators that simply and naturally provide the effective ventilation needed by everyone working and living in an indoor environment. When used with positive pressure ventilation, Freshvent 100 provides an important outlet for air circulating around the house. Stale air is expelled through the unit to the outside without letting in noise and draughts.

This makes Freshvent 100 particularly suited to the 'tight' construction of new homes - and provides a stylish alternative to traditional slot/airbrick ventilators. In addition, Freshvent 100 is ideal for older properties that have been refurbished with double glazing and loft insulation. They require ventilation to combat the problems associated with condensation.

Kitchens, utility rooms, bathrooms and toilets are rooms where conventional domestic extract fans are normally found. The natural ventilation principle of Freshvent 100 is particularly suitable for 'clean' living spaces such as bedrooms, lounges and work rooms.

There are four Vent-Axia Freshvent 100 models and an extensive range of accessories available to customise the units to your exact requirements. All units are easily dismantled allowing quick access to the filter for cleaning or replacement. The high capacity of the filter results in fewer filter changes. The damper plate is insulated against condensation and noise penetration.

Acoustic Duct Versions

Acoustically damped pipe fitted around unit to reduce external sources of noise such as traffic. Suitable for bedrooms and other rooms where low noise levels are a priority. Comes complete with Freshvent 100 db and Freshvent 100 Thermo db versions.

Free Area

Product	Equivalent free area
Fresh 100	3200
Fresh 100dB	3200
Fresh 100 Thermo	2640
Fresh 100 Thermo-dB	2640

Models

Freshvent 100

Pullcord operated. Designed to provide filtered air from outdoors while mixing it efficiently with the air in the room. Adjustable to increase or reduce the free area and airflow to suit a particular environment.

Model	Stock Ref
100	453200

Freshvent 100 dB

Pullcord operated. Adjustable to increase or reduce the free area and airflow to suit a particular environment. Supplied with acoustically damped pipe for applications requiring low noise levels.

Model	Stock Ref
100 dB	453208

Freshvent 100 Thermo

Thermostatically regulated, with the vent size automatically adjusting according to the temperature outside. As the temperature decreases the damper closes, opening again as the temperature rises. The built-in thermostat regulates the size of the damper opening so that it starts to close at 10°C and is completely closed at -5°C.

Model	Stock Ref
100 Thermo	453182

Freshvent 100 Thermo dB

Thermostatically regulated, with the vent size automatically adjusting according to the temperature outside. As the temperature decreases the damper closes, opening again as the temperature rises. The built-in thermostat regulates the size of the damper opening so that it starts to close at 10°C and is completely closed at -5°C. Supplied with acoustically damped pipe for applications requiring low noise levels.

Model	Stock Ref
100 Thermo dB	453253

All versions come with a standard general duty filter. Replacement filters are available.

Accessories

Model	Stock Ref
Filter for Freshvent 100	453188
Filter for Freshvent 100 Thermo	453197
Extension Bushing	453275

Storm Shield

May be fitted to the Freshvent range to prevent ingress of water and eliminate the risk of draughts and cold air surges. Closes entirely during storms. Particularly suitable for high-rise/coastal applications or anywhere exposed to high winds.

Not suitable for dB models.

Model	Stock Ref
Storm Shield	453206

Dimensions (mm)

Model	Wall fixing hole dia Ømm	Max wall thickness mm
Freshvent 100	100	360
Freshvent dB 100	150	400
Freshvent 100 Thermo	100	320
Freshvent 100 Thermo dB	150	400

Cooker Hoods

Features & Benefits

- A choice of three styles for domestic applications
- Wall, ceiling or cabinet fixed
- Compatible with flat ducting or aluminium flexible ducting
- All models are provided with a charcoal filter and washable grease filter as standard
- All models are fitted with mains lead, built-in lighting and choice of 3 speeds



Kitchen Ventilation

Vent-Axia offers a range of cooker hoods for the removal of cooking odours and steam at source in the domestic kitchen. Each model is designed to provide the extraction levels necessary to comply with Building Regulation requirements for kitchens with ducted outlets plus models that provide higher outputs for busier kitchens.

A choice of styles is available to include wall, or cabinet fixed models to provide integrated ventilation in any modular fitted kitchen from a terraced galley kitchen to the most extensive layouts. Models are available that can re-circulate or extract with the use of ducting.

The Building Regulations for the mechanical ventilation of kitchens with open-able windows in dwellings require that extractor hoods should be capable of extracting at a rate of 30 l/s (108m³/h).

When used with ducting, the resistance of the entire system should be considered so that the required performance is achieved. Extractor hoods should not be sited where ambient temperatures are likely to exceed +50°C.

Models

Genova



A white cooker hood with 'flip front' glass visor and rear spigot design to be wall-mounted or mounted beneath a top cabinet. Offering three speeds with extract rates of 100/160/220m³/h.

Model **Stock Ref**
Genova **120801**

Rimini/Milano/Roma



The Rimini (500mm width), Milano (600mm width) and Roma (900mm width) are stainless steel chimney cooker hoods with an extending chimney to fit varying ceiling heights. Offering three speeds with extract rates of 340/420/460m³/h.

Model **Stock Ref**
Rimini **427166**
Milano **120841**
Roma **120851**

Dimensions (mm)

Model	W	D	H
Genova	600	470	150
Napoli	600	275	400
Rimini	500	500	1115
Milano	600	500	1115
Roma	900	500	1115

Extractor hoods are not suitable for use above an eye level grill. Must be mounted between 760mm and 900mm above the hob.

Pull-out System Hood

Features & Benefits

- Models available with either a White or Brushed Aluminium trim
- Fits within a 600mm wide aperture (300mm deep)
- Complete with two low energy 9W lamps
- All models are fitted with a metal washable grease filter as standard
- 125mm galvanised duct connection piece
- Integral fire damper in accordance with BRE 398
- Weight: 3.7kg



Product

The Pull-out System Hood is designed to fit in a 600mm aperture above a hob. The telescopic hood incorporates two flat removable metal grease filters, two low energy light bulbs and is available with a White or Brushed Aluminium front trim.

The hood contains an integral fire damper in accordance with BRE Digest 398 and is connected to the mechanical ventilation unit by a galvanised steel duct connection piece. When the hood is opened the mechanical ventilation unit goes to boost speed.

Why install a cooker hood?

Steam created during the cooking process can cause moisture to form on walls and furniture. In extreme cases this can lead to mould growth. Strong smells can also be created during cooking and these can spread throughout the dwelling. Cooking oils may be vaporised when frying and this oil can be deposited in areas around the cooker.

The solution

When connected to an MEV or MVHR system, the Pull-out System Hood can be wired in such a way that when the hood part of the unit is pulled out the MEV or MVHR system will automatically switch to boost.

The Pull-out Hood System Hood comes with an integrated 125mm galvanised spigot to allow for connection to the MEV or MVHR system.

Models

Model	Stock ref
White System Hood	407509
Aluminium System Hood	407206

Dimensions (mm)

TOP

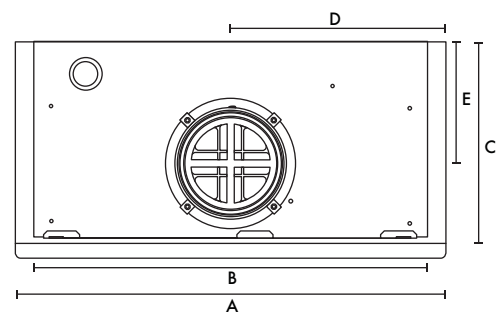

SIDE

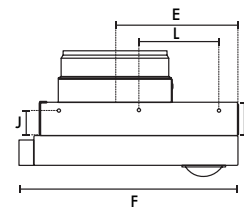

FRONT

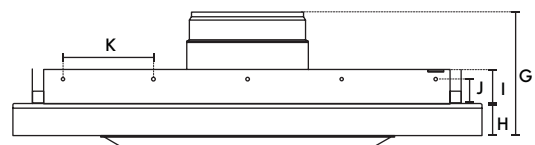

A	B	C	D	E	F	G	H	I	J	K	L
598	570	280	299	126	300	158	41	50	40	120	110

Basics Range



Bathroom/Toilet

BAS100B

Unshuttered axial fan for remote or light switch operation.

Stock Ref

436519

BAS100P

Unshuttered axial fan with integral pullcord.

Stock Ref

436520

BAS100T

Unshuttered axial fan with adjustable overrun timer.

Stock Ref

436521



Kitchen

BAS150B

Unshuttered axial fan designed for remote or light switch operation.

Stock Ref

436525

BAS150P

Unshuttered axial fan with integral pullcord.

Stock Ref

436526

BAS150T

Unshuttered axial fan with adjustable overrun timer.

Stock Ref

436527



Shower Fan & Kit

The kit consists of a IP44 In-Line fan, a white ceiling grille and spigot, 3 meters of flexible duct and an external louvre for soffit or wall mounting.

Minivent SK

Single speed 100mm in-line axial fan.

Stock Ref

248710

Minivent SKT

Single speed 100mm in-line axial fan with integral adjustable overrun timer - 5-30 minutes.

Stock Ref

248810



BAS100SLB

Single speed axial fan with integral back draught shutter for remote or light switch operation.

Stock Ref

436530

BAS100SLT

Single speed axial fan with electronic overrun timer (5-30 minutes) and integral back draught shutter.

Stock Ref

436532



BAS150SLB

Single speed axial fan with integral back draught shutter for remote or light switch operation.

Stock Ref

436533

BAS150SLT

Single speed axial fan with electronic overrun timer (5-30 minutes) and integral back draught shutter.

Stock Ref

436535



Shower Fan & Light Kit

The kit consists of a 100mm axial in-line fan 3 meters of flexible ducting, an exterior grille, light transformer and 12V 35W dichroic halogen light assembly. IP44 rated.

Basic

Stock Ref

432504

Timer

Stock Ref

432505

Eclipse 100 & 150

Features & Benefits

- Wall or Ceiling mountable
- Integral back draft shutter mechanism
- Meets current Building Regulations Approved Document F
- 100mm and 150mm size options
- Fixing kits available
- Fan IP44 rated -100mm
- Fan IPX4 rated -150mm



Bathroom Ventilation

The Eclipse range of circular axial fans is designed to be installed in kitchens and bathrooms. Its simple design provides an unobtrusive fitting that is sympathetic with most interiors.

Models

ECLIPSE 100X

Single speed 100mm bathroom/toilet fan with back draught shutter.

Model	Stock Ref
100X	427310

ECLIPSE 100XP

Single speed 100mm bathroom/toilet fan with pullcord and back draught shutter.

Model	Stock Ref
100XP	427281

ECLIPSE 100XT

Single speed 100mm bathroom toilet fan with integral adjustable overrun timer (5-30 minutes) and back draught shutter.

Model	Stock Ref
100XT	427282

ECLIPSE 150X

Single speed 150mm kitchen fan with back draught shutter.

Model	Stock Ref
150X	427283

ECLIPSE 150XP

Single speed 150mm Kitchen fan with pullcord and shutter.

Model	Stock Ref
150XP	427313

Accessories

Model	Stock Ref
Bezel Chrome 100mm	436480
Bezel Silver 150mm	436483

Wall Kit

Wall fixing hole for 150mm Ø165mm.

Model	Stock Ref
Wall Kit White	140902
Wall Kit Brown	140903

Wall fixing hole for 100mm Ø117mm.

Model	Stock Ref
Wall Kit White	254102
Wall Kit Brown	254100

Dimensions (mm)

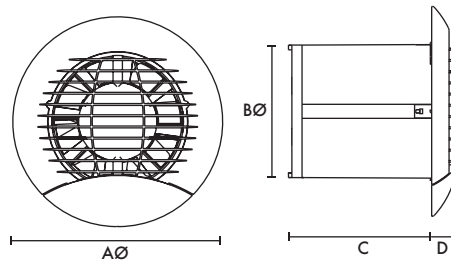

Model	A	B	C	D
Eclipse 100	157	99	107	19
Eclipse 150	201	144	123	19

Performance Guide

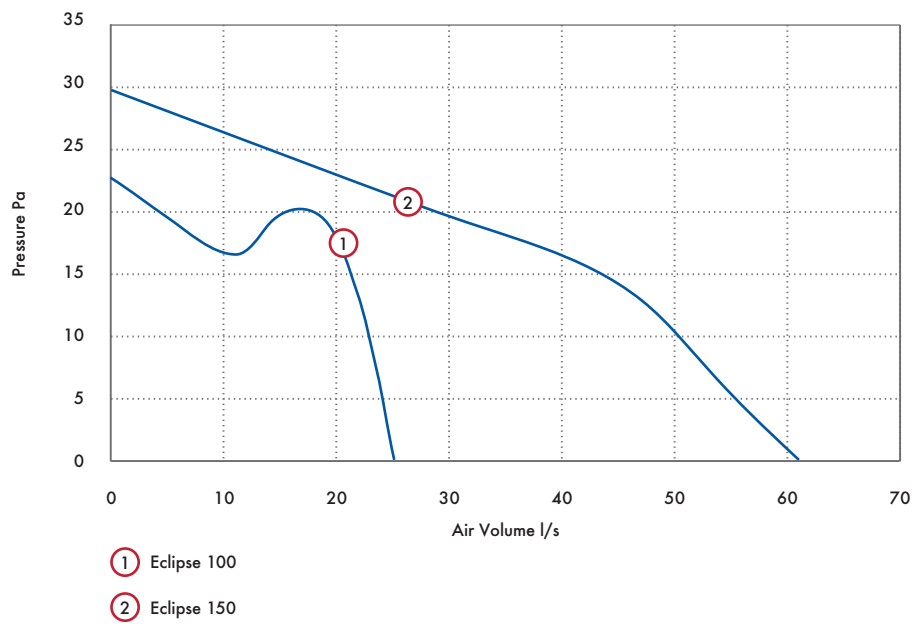

Model	Curve Ref	Extract Performance			dB(A)
		m ³ /h	l/s	Watts	@ 3m
Eclipse 100	1	90	25	14	38
Eclipse 150	2	220	61	16	45

Tested at 240V 50Hz

dMEV, MEV & PIV Systems



What is dMEV & MEV?

The current Building Regulations Approved Document F gives examples of four main methods of ventilation. System 3, continuous mechanical extract ventilation, can be achieved using a single centralised extract unit such as the Sentinel Multivent ducted from 'wet' rooms (kitchen, bathroom, en-suite and WC) or by decentralised individual fans (dMEV) in the 'wet' rooms. The fans run continuously at near silent levels providing a simple and effective form of ventilation.

Lo-Carbon Response

The continuous running, constant volume Lo-Carbon Response dMEV unit features an innovative digital display. The unique display (patent pending) provides the calibrated installed airflow and pressure of the installation meaning that there is no need to test the installation with an airflow measuring device.

Quiet running and with high pressure development, the Response is best in class - an achievement that was recognised when it won Product of the Year at the prestigious Housebuilder Awards 2014.

Vent-Axia[®]





Lo-Carbon Centra®/SELV
dMEV Unit

68-69



Lo-Carbon Response/SELV
dMEV Unit

70-71



Lo-Carbon Multivent
MEV Unit

72-73



Multivent
MEV Unit

74-75



Lo-Carbon Sentinel® Multivent/Plus
MEV Unit

76-79



Lo-Carbon Multivent MVDC-MS/MSH
MEV Unit

80-81



Lo-Carbon PoziDry
Positive Pressure Unit

82-83



Lo-Carbon PoziDry Compact
Positive Pressure Unit

84-85

Lo-Carbon Centra/SELV

Features & Benefits

- Building Regulations Approved Documents F and L compliant, System 3 Continuous mechanical extract
- Recognised in SAP PCDB - Low SFP
- Discreet, tasteful styling
- IPX4 rated - IPX7 rated (SELV)
- dMEV Pressure detection device
- 5 Year Motor Guarantee
- Suitable for wall, ceiling, panel and window mounting
- SELV models supplied with remote transformer and suitable for 'Zone 1'



the **ELECTRICAL**
industry awards
WINNER 2011

Winners of the Energy Efficiency Initiative 2011 Award
with our Lo-Carbon Continuous Ventilation Product Range

What is de-centralised MEV (dMEV)?

Building Regulations Approved Document F gives examples of four main methods of ventilation. System 3, Continuous mechanical extract ventilation, can be achieved using a single centralised extract unit such as the Sentinel Multivent ducted to 'wet' rooms (kitchen, bathroom, ensuite and WC) or by decentralised individual fans, such as the Lo-Carbon Centra in the 'wet' rooms. The fans run continuously at near silent levels providing a simple and effective form of ventilation.

SELV (Safety Extra Low Voltage) is designed for areas where a fan can be installed within Zone 1 in a room where there is a fixed bath or shower. Ingress Protected (IP) to IPX7 Lo-Carbon Centra SELV can be fitted safely within the spray area. The separate transformer can be mounted away from the spray zone and out of reach from the bath or shower.

The Lo-Carbon Centra meets the latest requirements of the Building Regulations Approved Document F for wholehouse system ventilation and all models come with a 5 year motor guarantee.

Selection of the two trickle flow rates (6l/s or 9l/s) is via a simple 'jumper' on the control board. Different methods are available for operating the 15 l/s boost speed from a simple switched live to integral humidistat. See individual models for further details.

The attractive and discreet styling of the Vent-Axia Lo-Carbon Centra will complement the décor of any new home while virtually silent operation ensures optimum ventilation is achieved without intrusive noise.

Specific Fan Power

dMEV version recognised in SAP PCDB. Lo-Carbon Centra has a specific fan power of only 0.18 W/l/s in through-the-wall kitchen applications.

Models

Lo-Carbon Centra dMEV

Auto speed selection at installation and suitable for bathrooms or kitchens. The integral air pressure sensor checks the airflow when first installed and also helps the fan to compensate for external wind pressure.

Stock Ref
441782

Lo-Carbon Centra T/SELV T (Timer)

Ideal for bathroom and toilet applications, this unit runs continuously on trickle setting and may be boosted by the switched live input which activates the timer (fixed 15 min on T models, adjustable 5-30 minutes on SELV models).

Model	Stock Ref
T	442954
SELV T	443175

Lo-Carbon Centra TP/SELV TP (Timer/Pullcord)

For bathroom/toilet applications, the continuous running TP model is boosted by the pullcord which activates the timer (fixed 15 min on TP models, adjustable 5-30 minutes on SELV models).

Model	Stock Ref
TP	447127
SELV TP	447128

Lo-Carbon Centra HT/SELV HT (Humidistat/Timer)

For bathroom/toilet applications, the continuous running HT model is automatically boosted by the built-in humidistat or by a switched live input which activates the timer (fixed 15 min on HP models, adjustable 5-30 minutes on SELV models).

Model	Stock Ref
HT	442955
SELV HT	443176

Lo-Carbon Centra HTP/SELV HTP (Humidistat/Timer/Pullcord)

For bathroom/toilet applications, the continuous running HTP model is automatically boosted by the built-in humidistat or by the pullcord which activates the timer (fixed 15 min on HTP models, adjustable 5-30 minutes on SELV models).

Model	Stock Ref
HTP	443045
SELV HTP	443177

Accessories

Model	Stock Ref
150mm Conversion Kit	443334
Wall Kit White	254102
Wall Kit Brown	254100
Window Kit	442947
Ceiling Kit	443800

Dimensions (mm)

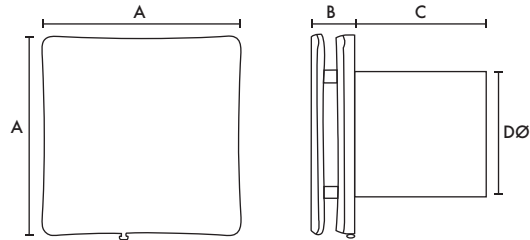

Model	A	B	C	DØ
Lo-Carbon Centra dMEV/All SELV	160	35	115	99
Lo-Carbon Centra T/TP/HT/HTP	160	35	80	99

Transformer 87 x 87 x 33mm (W x H x D) (SELV models only)

Performance Guide

Model	Extract Performance (l/s)			Power Consumption (Watts)			Sound dB(A)@ 3m		
	Trickle	Trickle	Boost	Trickle	Trickle	Boost	Trickle	Trickle	Boost
	Low	High		Low	High		Low	High	
Lo-Carbon Centra dMEV/All SELV	6	9	15	1.4	1.6	2.4	10.8	15.5	25.2
Lo-Carbon Centra T/TP/HT/HTP	6	9	15	3.2	3.5	4.2	10.8	15.5	25.2

SAP PCDB Performance (dMEV model)

Systems With Rigid Ductwork Installation Only

Unit Configuration	Location	Fan Speed Setting	Flow Rate (l/s)	SFP (W/l/s)
In Room (Ducted)	Kitchen	High	13.2	0.32
In Room (Ducted)	Wet Room	9 l/s	8.4	0.28
Through Wall	Kitchen	High	13.5	0.18
Through Wall	Wet Room	9 l/s	8.6	0.20

Systems With Flexible Or Mixed Ductwork Installation Only

Unit Configuration	Location	Fan Speed Setting	Flow Rate (l/s)	SFP (W/l/s)
In Room (Ducted)	Kitchen	High	13.2	0.37
In Room (Ducted)	Wet Room	9 l/s	8.6	0.31
Through Wall	Kitchen	High	13.5	0.18
Through Wall	Wet Room	9 l/s	8.6	0.20

Lo-Carbon Response/SELV

Features & Benefits

- Recognised in SAP PCDB
- Constant volume
- Display showing airflow and system pressure (Patent pending)
- Switched live connection for external switches/sensors
- 220-240V input
- Day logger feature on Humidistat models
- 6l/s or 8l/s trickle speed selection 13l/s boost speed
- IPX4 rated - IPX7 rated (SELV)
- Multi-orientation grille
- New comfort control option (Patent pending)



Lo-Carbon Response

Continuous running, constant volume dMEV unit with switched live (LS) and innovative digital display. Quiet running and with high pressure development, the Response is best in class.

The Response Fan from Vent-Axia

Following the introduction of the Domestic Ventilation Compliance Guide within Part F 2010, and the requirement to test the installed airflow of extract fans, the Response fan from Vent-Axia provides the easiest install available.

The unique display (patent pending) provides the calibrated installed airflow and pressure of the installation meaning that there is no need to test the installation with an airflow measuring device.

The constant volume technology automatically adjusts the speed of the fan to ensure the desired airflow is delivered. With a new silent higher pressure axial impeller Lo-Carbon Response can meet the requirements of many domestic installations without the need to use a traditional centrifugal fan.

Axial, rather than centrifugal?

Some centrifugal fans can develop pressure but the actual installed airflows can mean that the pressure is of no use as the airflow falls below the requirement. Using the new high pressure silent axial impeller has enabled the fan to not only develop great installed performance over duct runs, but to do it in the most energy efficient way. Response can provide excellent pressure whilst still maintaining energy efficiency and not wasting energy on high pressure at low air volumes. This enables the fan to save up to 64% of the specific fanpower (SFP) of the SAP PCDB data for existing centrifugal alternatives.

Configuration	Location	Alternative Centrifugal Fan SFP	Vent-Axia Response SFP
In room	Kitchen	0.38	0.17
	Wet Room	0.29	0.18
Through Wall	Kitchen	0.36	0.13
	Wet Room	0.28	0.15

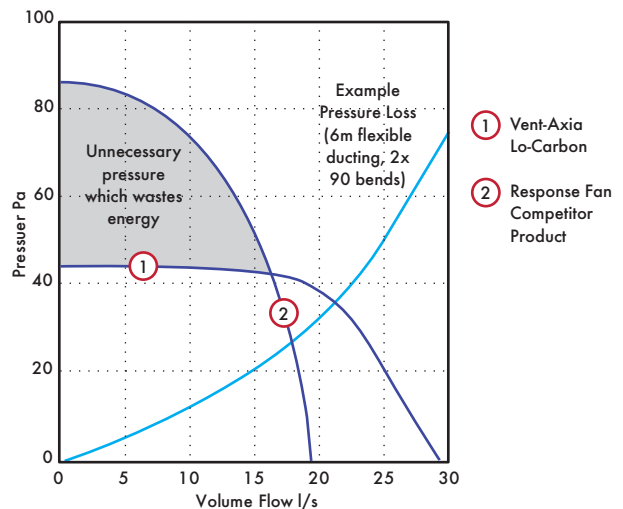

Side View of Airflow Display

Be confident that the Response is delivering the right performance with our innovative digital display showing the airflow and system pressure of the installed product.



Comfort Control Option

Designed to offer a more relaxing environment to the homeowner, the Lo-Carbon Response features a delayed start option. This new, patent pending, comfort control option is selectable at installation and allows the homeowner to enjoy a quiet, peaceful bathroom for up to 20 minutes before the Boost activates. Furthermore, if the light switch turns On and Off within 3 minutes, the Boost will not activate. No more disturbing the family if the bathroom light is turned on during the night.

Model

Lo-Carbon Response dMEV

Auto speed selection at installation. The integral air pressure sensor checks the airflow when first installed and also helps the fan to compensate for external wind pressure.

Stock Ref

404535

Lo-Carbon Response/SELV TP

(Timer/Pullcord)

For kitchen, utility and bathroom/toilet applications, the continuous running TP model incorporates an adjustable overrun timer. This adjusts the time the fan will continue to run on boost after the LS connection has been deactivated. This is also the run time period for the pullcord.

Model Stock Ref

TP **404876**

SELV TP **404878**

Lo-Carbon Response/SELV HTP

(Humidistat/Timer/Pullcord)

For kitchen, utility and bathroom/toilet applications, the continuous running HTP model incorporates an adjustable (40% - 90%) ambient response humidistat. The fan will increase the extract rate if the humidity rises above the point set at installation. Day logger as standard.

Model Stock Ref

HTP **404877**

SELV HTP **404879**

Accessories

Model Stock Ref

Wall Kit White **254102**

Wall Kit Brown **254100**

150mm Conversion kit **408680**

Ceiling kit **407928**

Window kit **407927**

Decoration Frame **474041**

Dimensions (mm)

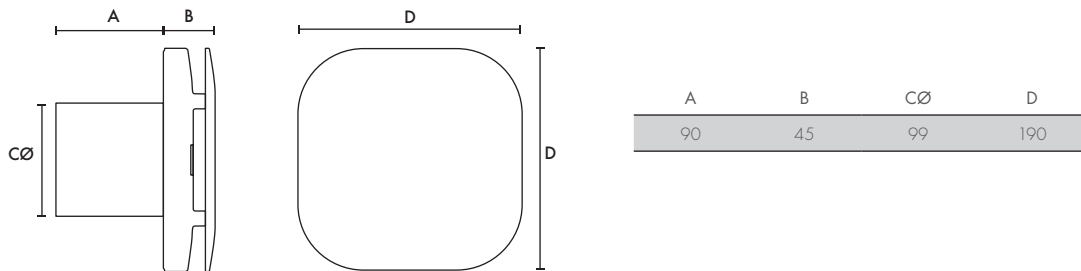

Performance Guide

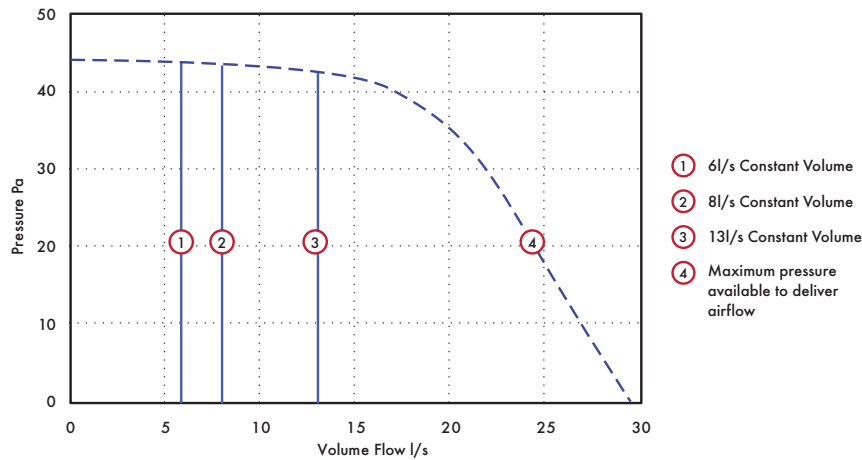

Model	Extract Performance l/s (m ³ /h) - FID			Watts			dB(A) @ 3m		
	Trickle Low	Trickle High	Boost	Trickle Low	Trickle High	Boost	Trickle Low	Trickle High	Boost
Lo-Carbon Response	6 (21)	8 (29)	13 (43)	1.0	1.2	1.7	12	17	32.5

SAP PCDB Performance

Unit Configuration	Location	SFP (W/l/s)
In room (rigid duct)	Kitchen	0.17
In room (rigid duct)	Wet Room	0.18
In room (flex duct)	Kitchen	0.17
In room (flex duct)	Wet Room	0.16
Through wall	Kitchen	0.13
Through wall	Wet Room	0.15

Lo-Carbon Multivent

Features & Benefits

- Reduces your carbon footprint
- Fitted with four extract 100 or 125mm diameter spigots allowing quick connection to ducts
- Option of wall, ceiling and loft mounting
- Quiet running suitable for continuous operation
- Can extract from a number of rooms, depending on the dwelling
- Wireless Controller available



The Lo-Carbon Multivent continuous mechanical extract ventilation range is designed for the simultaneous ventilation of separate areas in the home or as a multipoint extractor system for a wide range of commercial applications.

In the home the system is usually located in the loft or airing cupboard with ducts taken to the bathroom, utility room and toilets to remove air pollutants such as water vapour and odours.

Lo-Carbon Multivent is ideal for a range of commercial applications such as toilets, fitting rooms, and kiosks. The units can be installed at any angle and where the ambient air has a high humidity content condensate drains are provided.

The Lo-Carbon Multivent H version incorporates a built-in humidity sensor to switch between two of the three speeds. A Wireless Controller is available for use with the Lo-Carbon Multivent H with three speed options offering total control of the system.

Lo-Carbon MVDC

The Lo-Carbon MVDC Multivent minimises running costs by incorporating the latest DC technology. DC efficiency means less wear and tear on the motor which guarantees longer life.

Extended motor guarantee to 5 years offered.

Models

Model	Stock Ref
MVDC	181520
MVDCH	183020

Accessories

Acoustic Lining Kit

For reducing noise in sensitive installations

Stock Ref
438195

Multivent Wireless Controller

(for use with MVDCH only)

Stock Ref
426035

Dimensions (mm)
Weight: 5.50kg

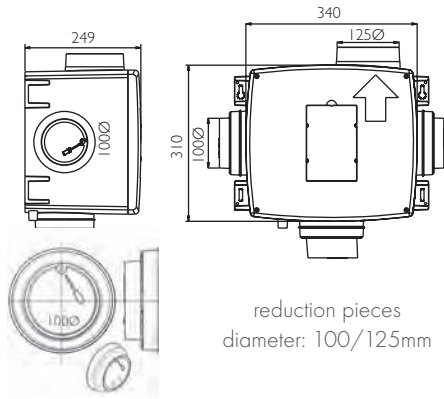

Performance Curve

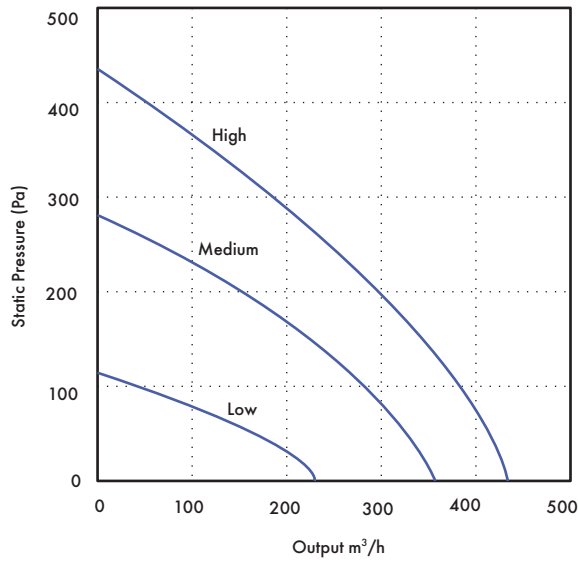

Technical Data

Model	Low		Medium		High		SEC Class	SEC Class (inc. LDC)
	Current Amps	Power Watts	Current Amps	Power Watts	Current Amps	Power Watts		
MVDC	0.1	9	0.23	20	0.39	44	E	B
MVDCH	0.1	9	0.23	20	0.39	44	D	B

Sound Level

Model	FID Perf. m³/h (l/s)	Sound dB(A) @ 3m		
		Casing Breakout	Duct Inlet 100mmØ	Duct Inlet 125mmØ
MVDC				
low	232 (64)	33.3	36.5	36.5
medium	365 (100)	33.7	47.9	47
high	434 (120)	38.8	51.7	51.5
MVDCH				
low	232 (64)	33.3	36.3	36.5
medium	365 (100)	33.7	47.9	47
high	434 (120)	38.8	51.7	51.5

Multivent

Features & Benefits

- Fitted with four extract 100 or 125mm diameter spigots allowing quick connection to ducts
- Option of wall, ceiling and loft mounting
- Quiet running suitable for continuous operation
- Can extract from a number of rooms, depending on the dwelling
- Wireless Controller available



The Multivent continuous mechanical extract ventilation range is designed for the simultaneous ventilation of separate areas in the home or as a multipoint extractor system for a wide range of commercial applications.

In the home the system is usually located in the loft or airing cupboard with ducts taken to the bathroom, utility room and toilets to remove air pollutants such as water vapour and odours.

Multivent is ideal for a range of commercial applications such as toilets, fitting rooms and kiosks. The units can be installed at any angle and where the ambient air has a high humidity content condensate drains are provided.

The Multivent H version incorporates a built-in humidity sensor to switch between two of the three speeds. A Wireless Controller is available for use with the Multivent H with three speed options offering total control of the systems.

Models

Model	Stock Ref
MV250	181510
MV250H	183010

Accessories

Acoustic Lining Kit

For reducing noise in sensitive installations

Stock Ref

438195

Multivent Wireless Controller

(for use with MV250H only)

Stock Ref

426035

Dimensions (mm)
Weight: 5.50kg

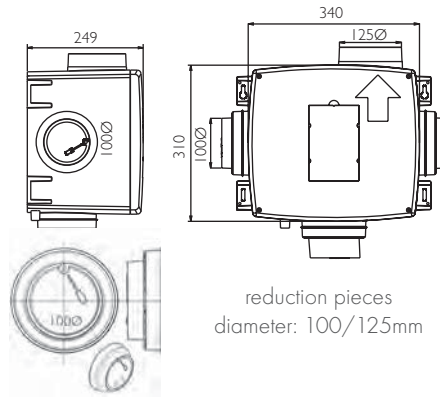

Performance Curve

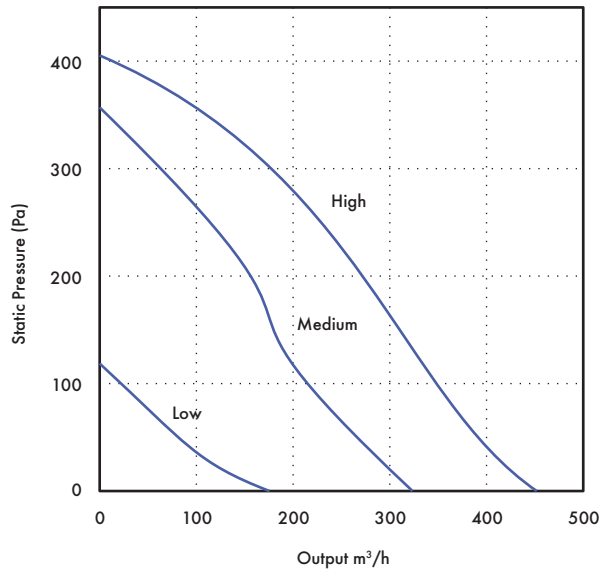

Technical Data

Model	Low		Medium		High		SEC Class	SEC Class (inc. LDC)
	Current Amps	Power Watts	Current Amps	Power Watts	Current Amps	Power Watts		
MV250	0.2	25	0.30	54	0.34	81	E	C
MV250H	0.2	25	0.30	54	0.34	81	E	C

Sound Level

Model	FID Perf. m³/h (l/s)	Sound dB(A) @ 3m		
		Casing Breakout	Duct Inlet 100mmØ	Duct Inlet 125mmØ
MV 250				
low	161 (45)	22.4	27.9	27.8
medium	305 (85)	31.0	42.9	43.2
high	443 (123)	35.4	48.6	48.0
MV 250H				
low	175 (48)	22.4	27.9	27.6
medium	344 (95)	31.0	42.9	43.2
high	443 (123)	35.4	48.6	48.0

Lo-Carbon Sentinel Multivent/Plus

Features & Benefits

- Reduces your carbon footprint
- Recognised in SAP PCDB
- Specific fan power 0.16 W/l/s (K+1)
- Suitable for use with external sensors and controllers
- Wireless control option
- Complies with Building Regulations ADF and ADL
- Manufactured in the UK from recyclable materials



Sentinel Multivent continuous mechanical extract ventilation, MEV is designed for the simultaneous ventilation of separate areas in the home or as a multipoint extraction system for a wide range of commercial applications. The units can be installed at any angle. Where the ambient air has a high humidity content condensate drains are provided.

In support of Sentinel Multivent, Vent-Axia offers:

- Practical advice on product selection and installation
- Guidance on solutions to meet legislation requirements
- Project management and site deliveries
- After sales support and maintenance information

The need to improve efficiency

Sentinel Multivent has been designed to meet the exacting demands of developers, installers and users offering advanced control options and easier installation and commissioning.

- Demand Control - enables precise ventilation rate, is set in 1% increments based on property size
- Integral LCD display allows the installer to select appropriate low, normal and boost speeds to meet demand
- Manual and automatic control options
- Integral adjustable overrun timer and delay on timer
- Plug-n-Play automatic sensor detection
- Switched live and SELV connections
- Dry Out setting - Option set at installation, Sentinel Multivent will run on boost for 1 week to assist in removing moisture
- Optional Wireless Control - up to 4 controllers on any one system
- Energy efficient EC/DC motors - 1/3 less energy lost to heat than a conventional AC motor
- Low Specific Fan Power (SFP) making it one of the most efficient products on the market

Legislation

- Meets Building Regulations Approved Document F (System 3)
- Recognised in SAP PCDB up to kitchen + 6 wet rooms

- Meets carbon footprint reduction targets
- Lowest SFP figures of any demand control MEV system

The need for better health

Removal of pollutants such as moisture, carbon dioxide and external fumes are all important factors in maintaining indoor air quality, helping to create a healthier living environment.

- The integral humidity sensor (Sentinel Multivent H) increases fan speed in proportion to relative humidity levels, saving energy and reducing noise
- The sensor also reacts to small but rapid increases in humidity, even if the normal trigger threshold is not reached. This unique feature ensures adequate ventilation, even for the smallest wet room
- Night time relative humidity increment setback feature suppresses nuisance tripping as humidity gradually increases with falling temperature
- Acoustically lined - low noise levels only 18.1 dB(A) @ 3m

SAP PCDB

In order to make the right choice, developers and contractors should refer to Building Regulations ADL1a, SAP 2012 and SAP PCDB.

SAP PCDB was launched in June 2006 to reward innovative ventilation manufacturers by testing and listing energy efficient products that assist in helping developers meet their Target Emission Rates (TER).

SAP is the underpinning methodology behind the Energy Performance Certificates and is used to demonstrate compliance with Building Regulations for Dwellings - Approved Document L (England and Wales), Section 6 (Scotland) and Approved Document F (Northern Ireland). SAP PCDB specifically relates to wholehouse ventilation systems and lists a number of Vent-Axia Mechanical Ventilation solutions which offer an improved SAP rating over and above the default for these product types.

SAP PCDB Test Results (Sentinel Multivent Plus)

Exhaust Terminal Configuration	Fan Speed Setting	Total Flow Rate	SFP (W/l/s)
K+1	20%	21	0.25
K+2	25%	29	0.22
K+3	30%	37	0.22
K+4	34%	45	0.22
K+5	40%	53	0.25
K+6	45%	61	0.27

SAP PCDB Test Results (Sentinel Multivent)

Exhaust Terminal Configuration	Fan Speed Setting	Total Flow Rate	SFP (W/l/s)
K+1	32%	21	0.16
K+2	39%	29	0.16
K+3	49%	37	0.17
K+4	59%	45	0.21
K+5	68%	53	0.24
K+6	77%	61	0.29

To assist developers and contractors Vent-Axia can provide detailed scheme designs together with installation guidance and training.

Your Carbon Footprint

The Carbon Footprint is a measure of the amount of carbon dioxide (CO₂) emitted through the burning of fossil fuels. From a residential and commercial building perspective, it is the amount of carbon generated when you consume a kilowatt of electricity. Reducing a building's carbon footprint will ultimately reduce electricity bills and save money for every individual household or business. It will also help meet the UK target for the reduction of emissions, as well as allowing you to help the environment.

Model

Model	Stock Ref
Sentinel Multivent	437601
Sentinel Multivent H	445655
Sentinel Multivent Plus	407001
Sentinel Multivent Plus H	407849

Dimensions (mm)

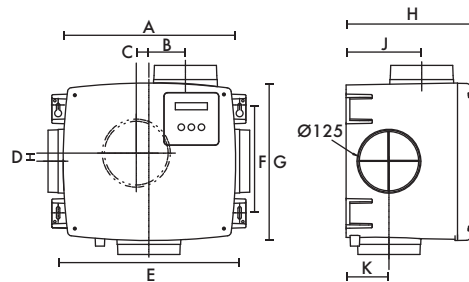

Reduction Pieces
Diameter: 100/125mm

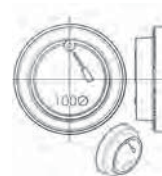

A	B	C	D	E	F	G	H	I	J
340	72.5	25	15	360	214	310	260	150	85

Performance Guide

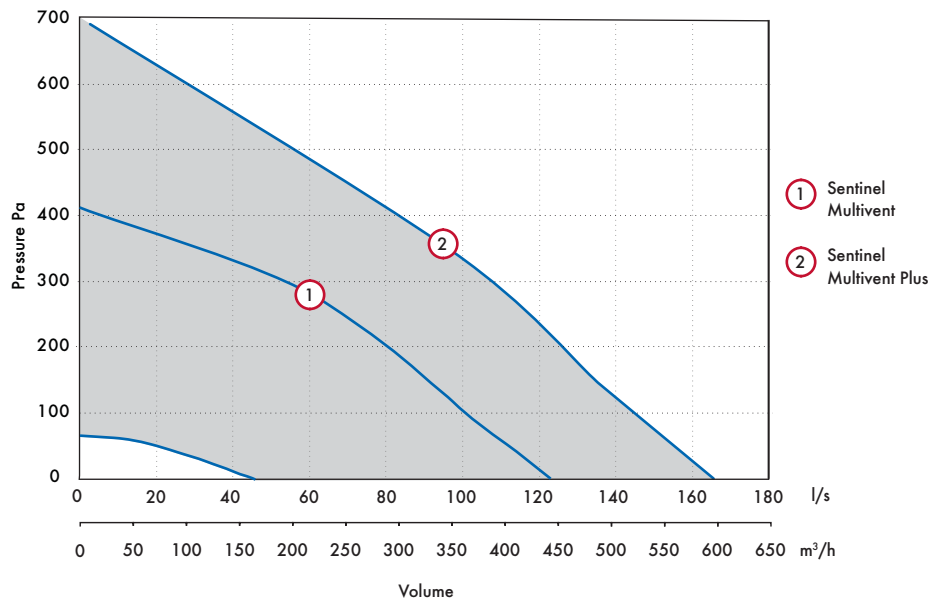

Stock Ref	Model	Curve Ref	Inlet Duct dB(A)	FID l/s	Power Watts	SEC Class	SEC Class (inc. LDC)
437601 / 445655	Multivent	1 (max)	38	121	45	E	B
407001 / 407849	Multivent Plus	2 (max)	-	165	83	E	B

Sound Data (Sentinel Multivent Plus)

Speed %	Test mode	Octave band, Hz, dB SWL								SPL dB(A) at 3m
		63	125	250	500	1k	2k	4k	8k	
20	Inlet	45.0	46.0	43.9	34.1	27.4	22.8	23.1	29.7	20.5
	Outlet	45.0	40.9	45.2	39.5	33.0	26.7	23.0	29.1	29.5
	Breakout	43.9	37.4	36.5	35.5	26.7	22.6	23.7	30.2	19.0
40	Inlet	48.6	48.7	54.4	52.3	55.4	47.5	38.0	33.1	37.0
	Outlet	49.1	54.6	54.4	55.0	55.7	51.7	39.7	39.5	42.9
	Breakout	45.2	44.2	47.5	46.1	40.0	34.0	26.3	30.3	26.8
60	Inlet	48.6	48.7	54.4	52.3	55.4	47.5	38.0	33.1	37.0
	Outlet	57.1	55.9	65.2	63.3	64.8	64.5	53.7	55.5	52.2
	Breakout	49.0	49.7	58.0	53.7	48.4	46.4	36.4	33.3	34.9
80	Inlet	56.3	56.6	60.4	59.0	61.4	56.0	46.6	43.5	43.5
	Outlet	62.3	60.8	70.9	69.3	69.5	70.3	61.9	62.8	57.9
	Breakout	53.1	53.7	61.8	61.4	53.4	54.5	44.9	41.9	41.3
100	Inlet	54.1	55.5	59.4	61.8	62.7	58.9	49.7	45.8	45.3
	Outlet	63.1	61.8	67.8	72.7	70.5	71.5	62.9	64.4	59.0
	Breakout	56.5	54.3	60.8	65.6	54.0	54.6	46.3	42.3	43.7

Sound Data (Sentinel Multivent)

Speed		Induct sound power levels dB								dB(A) @ 3m
		63	125	250	500	1K	2K	4K	8K	
10%	Breakout	43.6	37	36.9	30.6	26.2	22.8	23.6	30.4	18.1
	Extract	43.8	39.9	36.1	30.4	24.6	21.8	22.	30.3	17.8
28%	Breakout	44	44.4	43.3	39	31.1	26.1	24.3	30.1	22
	Extract	42.2	40.1	42.2	40.5	32	23.3	23.4	30.5	22
46%	Breakout	45	42.8	46.7	44.1	38.8	35.6	26.7	30.6	25.8
	Extract	40.8	42.5	46.4	44.4	41	31.1	25.3	30.3	26
82%	Breakout	46.3	48.3	50	52.1	48.4	47.7	37.8	32.4	33.7
	Extract	46.7	49.6	48.9	54.3	51.8	42.7	38.1	34.2	36.1

Controllers and Sensors

Sentinel Multivent can be used with a wide range of Vent-Axia controllers and sensors. Ranging from integral humidistats, through to wireless controllers to wired remote sensors.

Integral Humidistat

- Simple Plug-n-Play installation
- Eliminates the need for additional controllers or sensors
- Reacts to any rapid increases in relative humidity or when humidity rises above adjustable threshold
- Future proof - can be fitted after installation
- Self programming



Stock Ref

437598

Ambient Response Humidity Sensor

- Pullcord override and indication light
- Changeover relay switch
- Operating range: 30% - 90%RH
- Ambient operating temp. 5°C to 40°C
- 220-240V AC
- Will fit single gang box for surface mounting



Stock Ref

563550

Visonex PIR Sensor

- Fits any UK single gang mounting box
- Adjustable timer overrun (5-25 mins)
- Range of detection up to 10 metres
- Designed to meet IP43
- Ambient operating temp. range 0°C to 50°C



Stock Ref

459623

Wireless Transmitter Controller Receiver Kit

- Manual boost
- Adjustable overrun timer
- Easy wireless installation
- Reduces installation time
- Future proof - add more controllers any time



Stock Ref

439352

Ecotronic Humidity Sensor

- Set point adjustable
- Maximum switching load 1 Amp inductive
- Pullcord override indicator
- Ambient operating temp. 0°C to 40°C
- Supply voltage 220-240V



Stock Ref

563532

CO₂ + Temp Room Sensor

- 240V DC
- 0 - 2000ppm CO₂ working range
- 0 - 50°C working range
- Auto-calibrating NDIR CO₂ absorption sensor
- Thin film platinum temperature sensor for high accuracy



Stock Ref

433257

Wireless Transmitter Controller

- Additional controller for 439352
- A maximum of 4 controllers can be used per system
- Can be connected to other accessories (e.g. Humidistat) to send a boost signal wirelessly



Stock Ref

437827

Air Quality Sensor

- Ambient operating temp. 0°C to 50°C
- DEMKO approved
- Surface mounted
- 1 - 25 min O/R timer
- Supply voltage 220-240V



Stock Ref

563506

Ventwise

- Automatically boosts fan when temperature of the supply pipe to a shower or bath increases
- Automatically boosts fan when electric hob is switched on
- Can be used in conjunction with manual override input
- Adjustable overrun timer
- Two sensor options available



Stock Ref

435960

Lo-Carbon Multivent MVDC-MS/MSH

Features & Benefits

- Best in class Specific Fan Power
- Reduces your carbon footprint
- Recognised in SAP PCDB
- Fitted with four extract 125 or 100mm diameter spigots allowing quick connection to ducts
- Complies with Building ADF (System 3)
- Option of wall, ceiling and loft mounting
- Improved controllability
- Switched Live Boost connection
- Fully variable normal and boost speeds
- Ultra quiet - acoustically lined for low noise levels
- Integral humidistat (H version)



With growing concerns about accurate ventilation of properties, the Lo-Carbon Multivent MVDC range offers the option of 'Close Control' both in the residential and the commercial sectors. With a DC motor the multi speed Lo-Carbon Multivent is one of the most efficient central extract units available.

The units have two fully variable speeds for trickle and boost, with a switched live (LS) activation for the boost speed. An additional third speed (purge) is available using a second switched live connection.

An acoustic lining is included as standard, ensuring minimum noise levels.

The potentiometer controlled speed selector allows accurate setting of airflow, ensuring exactly the right ventilation rate. This feature also reduces noise, and energy consumption.

Models

	Stock Ref
MVDC-MS	437634
MVDC-MSH	443298

SAP PCDB Test Results

Exhaust Terminal Configuration	Total Flow Rate	SFP (W/l/s)
K + 1	21	0.16
K + 2	29	0.15
K + 3	37	0.17
K + 4	45	0.20
K + 5	53	0.24
K + 6	61	0.28

Dimensions (mm)

Weight: 5.50kg

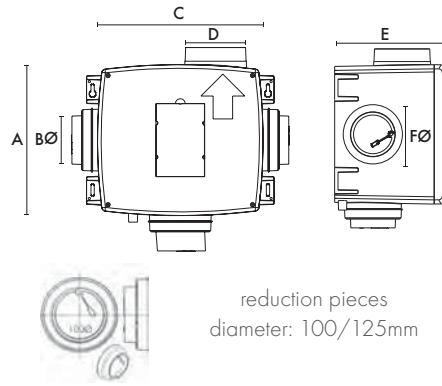

reduction pieces
diameter: 100/125mm

A	BØ	C	DØ	E	FØ
310	100	340	125	249	100

Performance Guide

MVDC-MSH features an integral humidistat which triggers the unit to boost when humidity levels in the duct system exceed 70%.

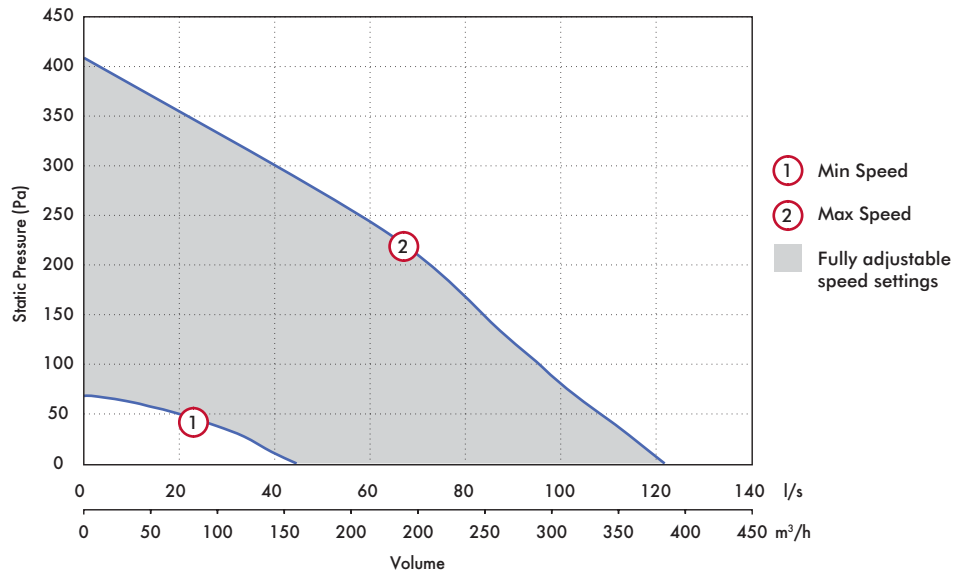

Model	Min				Max				
	Casing Breakout dB(A) @ 3m	Inlet Duct dB(A)	FID l/s	Power Watts	Casing Breakout dB(A) @ 3m	Inlet Duct dB(A)	FID l/s	Power Watts	SEC Class (inc. LDC)
MVDC-MS	19	18	43	6	37	38	121	45	E B
MCDC-MSH	19	18	43	6	37	38	121	45	E B

Lo-Carbon PoziDry

Features & Benefits

- BBA approved
- Reduces your carbon footprint
- Selectable air capacities to suit floor area up to 150m²
- Day logger feature as standard
- Uses latest Lo-Carbon motor technology for low running costs
- Ultra low sound level
- Complete with ceiling diffuser, flexible duct and worm drive clips
- Standard 5 year guarantee
- Up to 5 year maintenance free G4 filter
- IPX2 rated
- SFP of 0.22W/l/s



Positive Pressure Ventilation

For controlling condensation particularly in the refurbishment sector, the BBA approved Lo-Carbon PoziDry offers a quick and simple solution. A loft mounted positive input fan draws fresh air from the insulated loft, filters it and gently feeds it into the dwelling via a ceiling mounted diffuser. Stale air in the property is forced out through the natural forms of ventilation, such as window mounted trickle vents.

Installation

The Lo-Carbon PoziDry can be installed in a loft space and can be suspended from a roof beam or be floor mounted, with a purpose-designed diffuser normally located over the stairwell of a conventional two storey dwelling or in the main hall of a bungalow. The Lo-Carbon PoziDry is set to the appropriate speed at installation based on the size of the dwelling, providing positive pressure input ventilation. Background ventilation openings provide the exhaust points.

Performance

The robust construction of the Lo-Carbon PoziDry features a specially developed Lo-Carbon DC fan/motor arrangement which runs quietly and delivers incredibly low running costs. The Lo-Carbon PoziDry uses a sensor to monitor the temperature in the loft, automatically adjusting the air volume when necessary. 'Trickle' speed is automatically selected when the ambient loft temperature is up to 18°C. 'Normal' is automatically selected when the ambient loft temperature is between 18 and 27°C providing partial heat recovery.

If the ambient loft temperature exceeds 27°C, the Lo-Carbon PoziDry will automatically switch to standby (no airflow). The standby power consumption is 2W.

In the case of the integral 500W heater version, the heater element is automatically activated when necessary and tempers the supply air to 10°C. Can be used for air replacement in conjunction with an extract fan.

Filter

The unit includes a G4 filter with up to 5 years maintenance intervals to reduce the number of call outs needed throughout its life span.

Day logger

As standard. Measures the number of days the product has been switched on to provide precise running information.

Speed Control

With selection of 2 of 6 speeds available up to 50l/s, the unit is suitable for houses up to 360m³.

Heater

An optional comfort heater is available for operation when the incoming air temperature becomes low.

Air Replacement Grille Set

For air replacement through doors. Consists of a two-piece telescopic set, which fits unobtrusively on either side of the door panel. Minimum fixing thickness 30mm. Plastic. Dimensions: 454 x 90mm.

Typical Specification

The unit should be mounted in the loft space with a diffuser in self-extinguishing ABS positioned at the top of the stairwell. The unit meets the EMC and low voltage directives.

Motor

The electronically controlled DC motor is manufactured with long life ball bearings and is fitted with Standard Thermal Overload Protection (S.T.O.P.). Suitable for ambient operating temperatures of -25°C to +40°C.

For complete peace of mind, the Vent-Axia Lo-Carbon PoziDry is backed by a 5 year guarantee.

Models

Without heater

Stock Ref

444075

With integral heater

Stock Ref

444766

Accessories

Twin Spigot Kit

An additional kit to allow an extra circular diffuser to be installed near the PoziDry unit.

Stock Ref

449071

Includes:

1 x **436592** (200mm Duct)

2 x **561707** (Worm Clips)

1 x **452085** (200mm equal Y Piece)

1 x **10544200** (Diffuser)

Dimensions (mm)

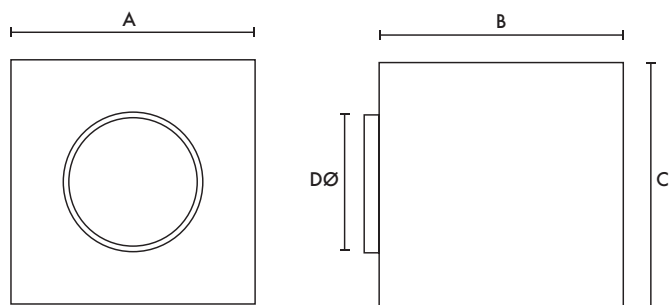

A	B (depth)	C	DØ	Weight
438	411	379	200	11.5kg

Performance Guide

Speed	FID (l/s)	Power (W)*	Floor Area up to (m ²)
1	10	2.5	30
2	18	3	54
3	26	4	78
4	34	5	102
5	42	7	126
6	50	13	150

*add 500W for heater version

Sound Data

Setting	Test mode	Octave band, Hz, dB SWL								SPL dB(A) at 3m
		63	125	250	500	1k	2k	4k	8k	
Speed 1	Supply	33.2	28.3	25.4	15.3	17.2	12.6	16.4	22.7	8.5
	Breakout/Intake	36.7	25.3	26.9	16.1	28.6	30.4	18.4	23.8	13.5
Speed 6	Supply	40.7	41.8	39.7	32.7	33.3	18.9	16.7	22.8	19
	Breakout/Intake	39.7	37.0	43.9	41.1	37.6	32.5	27.1	26.1	22.0

Lo-Carbon PoziDry Compact

Features & Benefits

- BBA Approved
- Ultra low sound level
- Selectable air capacities to suit volumes of up to 34 l/s or floor area up to 100m²
- Extremely low running costs - from less than one pence per day
- Washable, high capacity G4 filter
- Datalogger feature as standard
- Round to rectangular duct adaptor included
- 5 Year Guarantee
- Ideal for flats



Positive Pressure Ventilation

For those properties that do not have a loft, the BBA approved Lo-Carbon PoziDry Compact provides an easy to install solution. The unit is duct mounted and can be fitted in a number of locations within a single floor flat or apartment.

Air is drawn into the Lo-Carbon PoziDry Compact unit via an external inlet and through a short length of duct. The specially developed fan/motor assembly (using the Lo-Carbon DC motor technology) draws the air through an integral, high capacity, washable filter. The backward curved impeller guarantees increased efficiency, lower sound levels and better performance.

The fresh, filtered airflow passes along the ducting and terminates on an internal wall with a discreet grille. This directs the airflow upwards where the incoming air mixes with the warm air that gathers at ceiling height.

The system provides fresh, tempered air into the home and creates an indoor environment where the damaging effects of condensation find it hard to exist, benefiting both the occupants and the structure of the building.

The Lo-Carbon PoziDry Compact can be used for air replacement in conjunction with an extractor fan. A G4 filter is included as standard.

Performance

The Lo-Carbon PoziDry Compact uses a sensor to monitor the ambient temperature, automatically adjusting the air volume when necessary and providing partial heat recovery.

'Trickle' speed is automatically selected when the ambient temperature is up to 18°C.

'Normal' is automatically selected when the ambient temperature is between 18 and 27°C.

If the ambient temperature exceeds 27°C, the Lo-Carbon PoziDry Compact will automatically switch to standby (no airflow). The standby power consumption is 2W.

In the case of the integral 300W heater version, the heater element is automatically activated when necessary and tempers the supply air to 10°C.

Air Replacement Grille Set

For air replacement through doors. Consists of a two-piece telescopic set, which fits unobtrusively on either side of the door panel. Minimum fixing thickness 30mm. Plastic. Dimensions: 454 x 90mm. See Ducting section.

Day logger

As standard. Measures the number of days the product has been switched on to provide precise running information.

Model

Without heater
Stock Ref
444076

With integral heater
Stock Ref
444767

Installation Packs

Stock Ref 453546 453547 453548

Quick Fit Grille (White)	1	1	1
Wall fitting kit (Brown)	1	1	1
Round to Rectangle Adaptor	1	3	3
Vertical 90° bend	2	2	2
Elbow/Spigot	1	1	1
1m Flat Channel	1	2	2
1.5m Flat Channel	1	2	2
Connector	1	4	4
Horizontal 90° Bend	-	-	2
Channel Clip	4	6	2

Dimensions (mm)

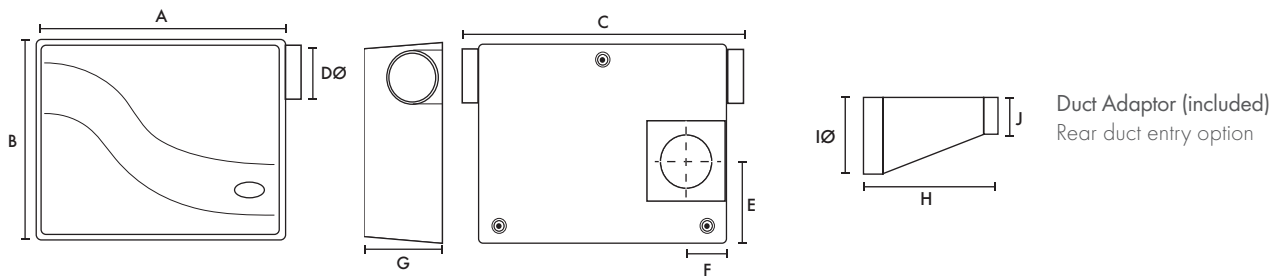

Duct Adaptor (included)
Rear duct entry option

A	B	C	DØ	E	F	G	H	IØ	J	Unit Weight
435	365	490	100	160	58	160	180	105	55 x 110	7kg

Performance Guide

Speed	FID (l/s)	Power (W)*	Floor Area (m ²)	SEC Class
1	10	5.7	30	E
2	18	12.2	54	
3	26	24.6	78	
4	34	49.8	100	

*add 300W for heater version

Sound Data

Setting	Test mode	Octave band, Hz, dB SWL								SPL dB(A) @ 3m
		63	125	250	500	1k	2k	4k	8k	
Speed 1	Supply	37.6	32.7	33.4	35.0	29.8	27.5	18.2	22.6	18.0
	Extract	37.0	32.3	32.5	32.4	21.9	25.3	16.8	22.6	15.5
	Breakout	35.3	46.9	38.8	33.1	22.9	22.2	17.8	23.3	15.0
Speed 4	Supply	65.2	57.2	60.8	67.6	62.2	59.7	50.8	41.2	50.0
	Extract	60.8	51.7	58.5	62.1	56.1	56.4	45.2	37.9	45.5
	Breakout	57.2	55.2	55.5	63.3	55.1	52.2	44.1	32.9	41.5

Residential & Commercial Single Room dMVHR



Improving air quality on a room-by-room basis, the Vent-Axia through-the-wall mounted range of heat recovery ventilation units simultaneously extract stale air and introduce fresh air - warming the incoming airflow with heat recovered from the exhaust stream.

Lo-Carbon Tempra

The Vent-Axia Lo-Carbon Tempra through-the-wall heat recovery unit provides a flexible solution, which meets the requirements for high efficiency ventilation. Tempra is ideal for refurbishment projects and is designed for use in bathrooms, toilets, utility rooms and kitchens. Tempra also meets the current Building Regulations Approved Document F and L.

Vent-Axia[®]

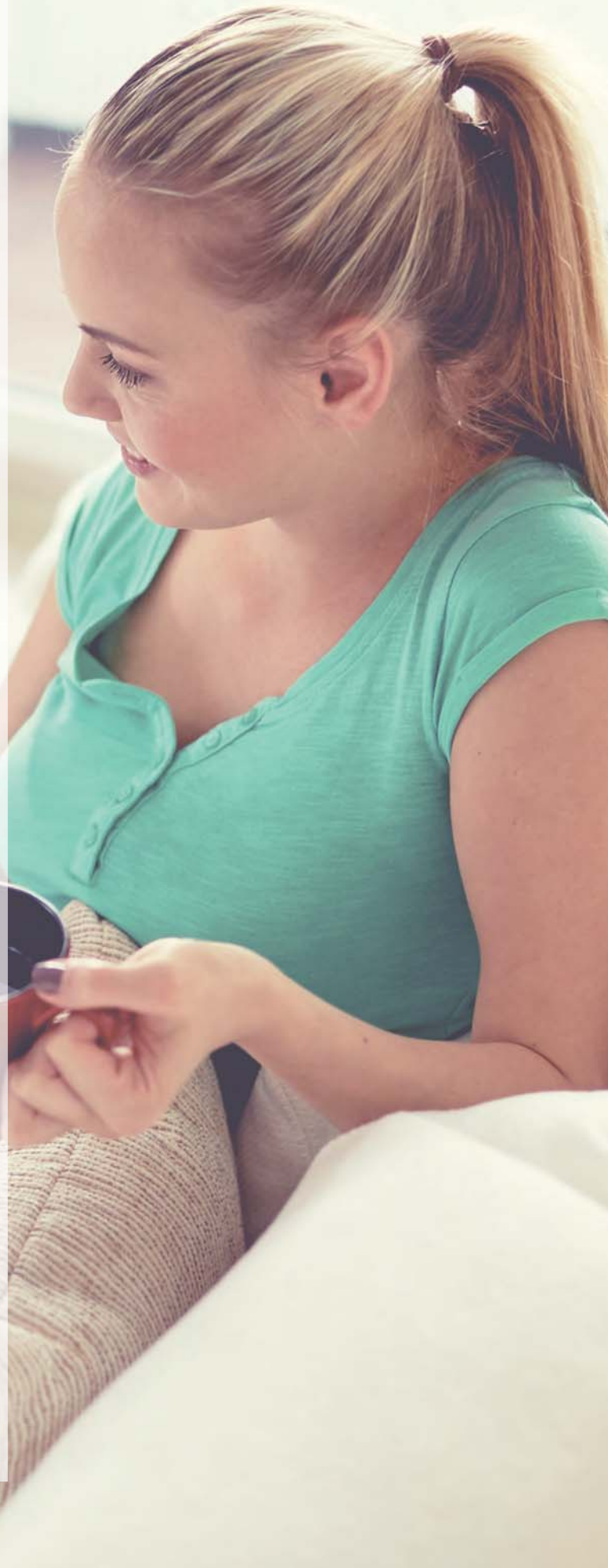



Lo-Carbon Tempra/SELV

88-89



Lo-Carbon HR25

90-91



HR200WK

92-93



HR300

94-95

Lo-Carbon Tempra/SELV

Features & Benefits

- Fits in 100mm diameter hole - ideal for refurbishments
- Up to 78% heat recovery
- Available in 2 wall depths: 320mm and 460mm
- Reduces the home's carbon footprint
- IPX4 rated
- Summer setting (extract only)
- Helps prevent noise ingress
- Continuous running or intermittent extract
- Meets current Building Regulations Approved Documents F and L
- Low power consumption - only 3.2 W



Through-The-Wall Heat Recovery Unit

The Vent-Axia Lo-Carbon Tempra is designed to fit in 100mm diameter hole and is suitable for refurbished properties in kitchen, bathroom, toilet or utility rooms. The unit meets the performance requirements for continuous extract fans under the current Building Regulations Approved Document F.

The Tempra is available in three models, a P version with pullcord control, a T version with overrun timer and an HTP version with built-in pullcord, overrun timer and humidistat. Two spigot lengths are available; 320mm and 460mm.

The manual summer setting allows the unit to be set to extract only, helping to prevent a dwelling becoming too warm in hot summer conditions.

Performance

Tempra can be set to run continuously at 6 l/s or 9 l/s, boosting up to 15 l/s, recovering heat from extracted air and returning it to the dwelling. The unique, compact heat exchanger has a temperature efficiency up to 78%, saving energy and reducing your carbon footprint. For intermittent extract the Tempra is set to 15 l/s.

The Tempra is also designed so that the replacement air being introduced is at a reduced rate ensuring that the room being ventilated is still under a slight negative pressure. This ensures that fresh air is brought into the room from the rest of the house preventing humid air migrating.

The Lo-Carbon EC/DC motor with twin impellers consumes as little as 3.2 Watts on trickle rate and runs almost silently at only 20dB(A).

Typical Installation

The unique heat exchanger design allows the Tempra to be fitted in a 100mm diameter hole, allowing it to replace standard 100mm extract fans while giving all the benefits of heat recovery. Maximum wall thickness is 460mm.

A longer version of the Tempra is available, designed for installations where the wall thickness is between 321mm and 460mm. 460mm models are identified by an 'L'.

Models

Lo-Carbon Tempra P (Pullcord)

Constant trickle speed with pullcord to boost or intermittent operation by pullcord.

Model	Stock Ref
320mm P	443312
320mm SELV P	444368
460mm LP	403832
460mm SELV LP	403833

Lo-Carbon Tempra T (Timer)

Constant trickle speed with switch live to boost or intermittent operation by switch live.

Model	Stock Ref
320mm T	443310
320mm SELV T	444369
460mm LT	403834
460mm SELV LT	403835

Lo-Carbon Tempra HTP (Humidistat/Timer/Pullcord)

Constant trickle speed with humidistat and linked overrun timer to boost or intermittent operation by switch live.

Model	Stock Ref
320mm HTP	443311
320mm SELV HTP	444370
460mm LHTP	403836
460mm SELV LHTP	403837

Accessories

100mm High Rise Kit

320mm white duct with black seal.

Model	Stock Ref
100mm High Rise Kit	449011

Wall kit

Extendable Wall Tube suitable for both spigot lengths.

Model	Stock Ref
Wall kit	445529

150mm Conversion kit
 For replacement of 150 diameter fan.
 Stock Ref
403847

Dimensions (mm)

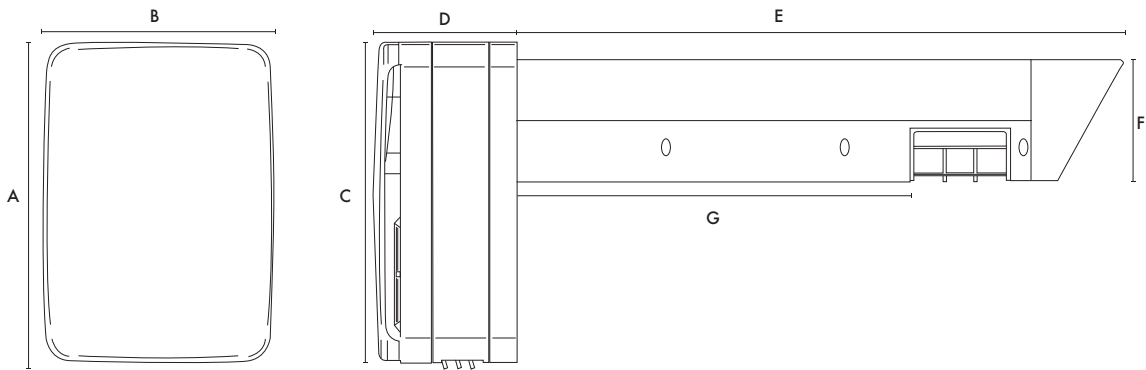

	A	B	C	D	E	F	G
Standard	266	190	262	117	496	99	321
Long	266	190	262	117	636	99	461

Performance

Model	Extract Performance l/s			Power Consumption Watts			Sound @dB(A)*		
	Trickle Low	Trickle High	Boost	Trickle Low	Trickle High	Boost	Trickle Low	Trickle High	Boost
Lo-Carbon Tempra (All Models)	6	9	15	3.2	5.7	26.6	20	22	36

*Octave band frequency range of 250Hz to 4KHz at 3m. Unit mounted on a reflective surface.

Heat Exchange - what is heat recovery?

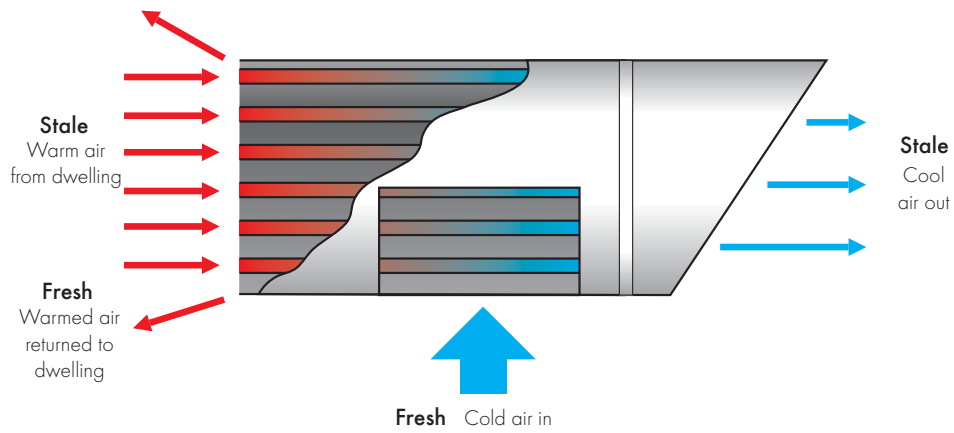

Lo-Carbon HR25

Features & Benefits

- Reduces the home's carbon footprint
- Designed for installations in bathrooms, toilets and utility areas
- 84% temperature based heat recovery
- Up to 90% energy saving
- Controls condensation and eliminates mould
- Choice of control options
- Long life, low energy DC motor
- IP24 rated



Long Life Ventilation

The Vent-Axia Lo-Carbon HR25 range of through-the-wall heat recovery units are suitable for fitting through a 152mm (6") circular hole and are designed for use in bathrooms, toilets and utility areas. The Lo-Carbon HR25 is available in two lengths, a standard version suitable for wall thicknesses of up to 310mm and an extended version suitable for wall thicknesses of up to 425mm. From a controllability perspective, the HR25 is available either with a standard pullcord switch or with an integral adjustable humidity sensor ('H' version), which will work automatically depending on the relative humidity in the room.

Performance

The units are fitted with a 24V DC motor and are supplied with a transformer which has the ability to operate at only 2 Watts power consumption on normal setting.

Maintenance

Apart from removing odours, providing fresh air and recovering heat, this appliance extracts airborne impurities such as dust, dirt and grease. Filters should be replaced every six months or as conditions necessitate.

Models

Lo-Carbon HR25

The HR25 is fitted with a pullcord switch which operates the twin speed control function.

Model	Stock Ref
Lo-Carbon HR25	372261

Lo-Carbon HR25H

The HR25H is fitted with an adjustable humidity sensor which automatically switches between its high and low settings depending on the relative humidity in the room.

Model	Stock Ref
Lo-Carbon HR25H	372262

Lo-Carbon HR25L

An extended version of the HR25 is available, designed for installations where the wall thickness is between 311 mm and 425mm.

Model	Stock Ref
Lo-Carbon HR25L	372264

Lo-Carbon HR25LH

An extended version of the HR25H is available, designed for installations where the wall thickness is between 311 mm and 425mm.

Model	Stock Ref
Lo-Carbon HR25LH	372265

Dimensions (mm)

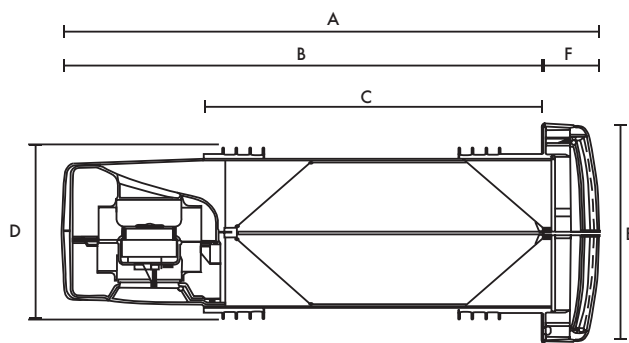

Top Profile

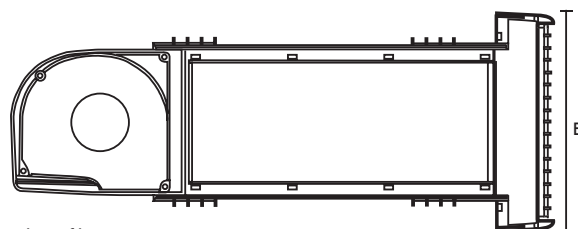

Side Profile

	A	B	C	D	E	F
Standard	508	451	318	147	204	54
Long	666	548	433	147	204	54

Standard - Weight 3.4kg, Long - Weight 3.5kg

Fixing hole \varnothing 152mm

Performance

Model	Extract Performance l/s (m ³ /h)		Intake Performance l/s (m ³ /h)		Watts		Sound dB(A) @ 3m*	
	Boost	Trickle	Boost	Trickle	Boost	Trickle	Boost	Trickle
HR25	15 (55)	5 (20)	10 (36)	2 (8)	23	2	49.2	16.8
HR25H	15 (55)	5 (20)	10 (36)	2 (8)	23	2	49.2	16.8
HR25L	15 (55)	5 (20)	10 (36)	2 (8)	23	2	49.2	16.8
HR25LH	15 (55)	5 (20)	10 (36)	2 (8)	23	2	49.2	16.8

*Octave band frequency range of 250Hz to 4KHz at 3m. Unit mounted on a reflective surface.

HR200WK

Features & Benefits

- Single room domestic heat recovery ventilation unit
- 3 speed motor
- Integral washable filter
- Up to 75% heat recovery
- Saves energy - controls condensation
- Low noise



Heat Recovery Ventilation

The Vent-Axia HR200WK is a heat recovery ventilation unit specifically designed for use in domestic kitchens and utility rooms to meet the Building Regulations. The unit is also suitable for light commercial applications up to 220m³/h (50l/s). The compact, self contained unit is designed for through-the-wall mounting.

The three speed, external rotor motor has two matched impellers to ensure a controlled airflow through the unit, with exceptionally economical 25 Watt low speed power consumption.

Easy Installation

The HR200WK fits through walls up to 335mm thick requiring a fixing hole 250mm square. The internal grille has washable, polymeric foam supply and extract filters. Only the neat internal twin grille is visible from the room. A wall extension sleeve is available for walls up to 550mm thick.

Heat Exchanger

The highly efficient, polymeric heat exchanger cube is washable. The compact cube interleaves outgoing moist warm air with incoming fresh air and allows the heat from one to warm the other without the two air streams mixing. Up to 75% of the heat, which would otherwise be lost, is transferred to the intake air, ensuring energy saving ventilation.

Electrical

HR200WK 220-240V/1/50Hz Class 1 earthed appliance. The 3 speed motor, can be wired to operate On/Off for any one of the three speeds. Alternatively, an Ambient Response Humidity Sensor or simple changeover switch can be used to provide switching between any two speeds, giving permanent trickle ventilation and automatic changeover to a higher speed during periods of high moisture generation. Also the 3 speed controller enables the unit to be switched from permanent trickle to either medium or boost speed.

Models

HR200WK

A heat recovery unit specifically designed for use in domestic kitchens and utility rooms to meet the latest building regulations. 3 speed motor, trickle ventilation mode, optional range of switches available.

Model	Stock Ref
HR200WK	14120020

Accessories

Model	Stock Ref
Extension Wall Sleeve	370421
Electronic Controller	W300310

Controllers

HR200WK Controller

A three position rotary control which enables the unit to be switched from permanent trickle ventilation to either medium or boost speed.

Model	Stock Ref
HR200WK Controller	563533

Dimensions (mm)

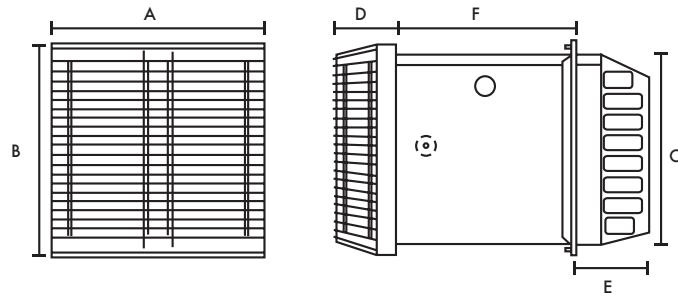

Wall fixing hole 250mm x 250mm sq.

A	B	C	D	E	F
270	270	245	85	68min	335max

Weight 9.7kg

Performance

	Performance l/s (m ³ /h)		Watts	% Heat Recovery	Sound dB(A) @ 3m	SEC Class	SEC Class (inc. LDC)
	Extract	Intake					
Speed 1	16 (60)	13 (50)	25	75	19	D	B
Speed 2	30 (110)	27 (100)	60	70	33		
Speed 3	61 (220)	55 (200)	140	65	46		

HR300

Features & Benefits

- Designed for continuous operation, providing up to 70% heat recovery
- Controls condensation and eliminates mould
- Speed controllable
- Quiet operation
- Washable filters



Heat Recovery Ventilation

The HR300 provides ventilation with heat recovery. It is ideal for light commercial applications including function rooms, offices, classrooms etc. The HR300 unit comes complete with an integral shutter.

Performance

The HR300 unit is designed for continuous operation providing up to 70% heat recovery. Effectively lowering internal relative humidity the HR300 unit controls condensation and eliminates mould.

Fresh, pre-warmed air from the outside is continually supplied to the room with simultaneous extraction of stale moist air and smells. Heat is transferred via a unique plastic heat exchanger from outgoing air to the fresh air supply with no cross contamination, maintaining internal temperatures and providing a fresh indoor environment.

The unit is fully controllable for speed using a small dedicated speed controller. Automatic ON/OFF control or switching to boost is easily achieved using sensors/timers e.g. humidistat. For summer operation the heat exchanger can be removed and replaced with a plastic divider board to provide positive cooling to rooms.

Installation

The HR300 unit requires a 380mm x 280mm hole. Units should be level and square in the wall. The unit should be fitted so that it overhangs by a minimum of 50mm on the inside, and a minimum of 70mm on the outside. An extension sleeve is available for walls up to 650mm thick.

Maintenance

The heat exchanger should be washed in warm soapy water every twelve months, or as conditions necessitate. Access to the filter and heat exchanger is via two screws on the internal grille.

Filters should be cleaned by washing every six months or as conditions necessitate. Replacement filters can be purchased in packs of two.

Models

Model	Stock Ref
HR300	370394

Accessories

Model	Stock Ref
Filters	370402
Extension Sleeve	370422
Electronic Controller	W300310
VCON6 Controller	370356

Dimensions (mm)

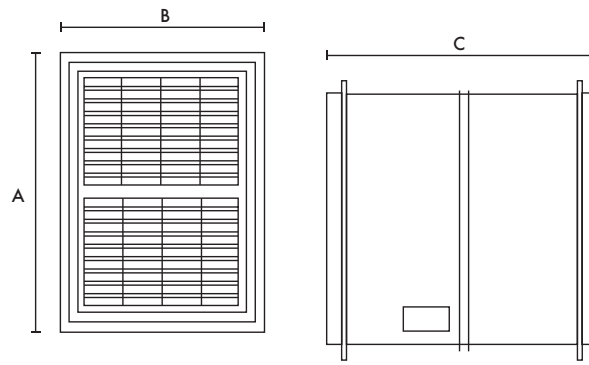

A	B	C
370	270	400

Weight 11kg

Performance

Model	Extract Performance l/s (m ³ /h)			Intake Performance l/s (m ³ /h)			Max Watts	Sound dB(A) @ 3m			SEC Class	SEC Class (inc. LDC)
	Low	Normal	Boost	Low	Normal	Boost		Low	Normal	Boost		
HR300	20 (75)	58 (210)	83 (300)	19 (70)	52 (190)	75 (270)	108	37	40	44	D	A

MVHR units for residential & commercial







A complete range of Mechanical Ventilation with Heat Recovery (MVHR) units for residential and commercial applications, including many that are recognised in the SAP Product Characteristics Database.

Lo-Carbon Sentinel Kinetic® Advance

The first of our new generation of MVHR systems incorporating a range of unique features. Offering units with wifi and App control options along with integrated digital controls for easy installation the range is designed with developers, specifiers and installers in mind. With over 93% efficiency and low specific fan powers down to 0.38 W/l/s; designers will see a reduction in their dwelling emission rate.

Vent-Axia®



	NEW Lo-Carbon Sentinel Kinetic [®] Advance MVHR Unit	98-99
	Lo-Carbon Sentinel Kinetic [®] Range Overview	100-103
	Lo-Carbon Sentinel Kinetic [®] MVHR Unit	104-107
	Lo-Carbon Sentinel Kinetic [®] FH MVHR Unit	108-111
	Lo-Carbon Sentinel Kinetic [®] Plus MVHR Unit	112-115
	Lo-Carbon Sentinel Kinetic [®] High Flow MVHR Unit	116-117
	Lo-Carbon Sentinel Kinetic [®] Cooker Hood MVHR Unit	118-121
	Lo-Carbon Sentinel Kinetic [®] Horizontal MVHR Unit	122-127
	Lo-Carbon Kinetic [®] Plus E MVHR Unit	128-131
	Integra Ducted MVHR Unit	132-133
	NEW Integra Plus EC Ducted MVHR Unit	134-135
	HR100R/RS Ducted MVHR Unit	136-137
	HR200V Ducted MVHR Unit	138-139
	HR500 Single Room Heat Recovery Unit	140-141
	HR500D Ducted MVHR Unit	142-143
	HR500EP/IP Passive HR Unit	144-145
	HR500DP Passive HR Unit	146-147

NEW Lo-Carbon Sentinel Kinetic Advance

Features & Benefits

- Ultra quiet
- Touch screen controller
- Lightweight for easier installation
- 100% Summer bypass
- WiFi connectivity option
- Wireless commissioning
- Pre-commissioning via USB
- App control option
- Left/Right handing through the controller
- Pre-heater option for cold climates
- Post-heater control option



The Sentinel Kinetic Advance from Vent-Axia is the next generation of heat recovery ventilation systems. It is designed to offer the highest level of comfort and control available ensuring the best possible customer experience.

A whole new experience

The highly sculpted interior surfaces, designed using the latest CFD techniques, ensures airflows are maximised through the unit minimising noise and energy use. This feature alone provides an experience which we are confident will delight home owners and fulfil our ambition of providing the most discrete and efficient ventilation available.

With the widest range of options available, installers can now order a system that is tailored to their client's needs.

Air Quality and Health

We have strived to make the Advance system the most flexible solution available on the market. Optimisation has been targeted in every aspect of the design to ensure that it really does improve quality of life. Whatever the outside environment, we have a method to help reduce air pollution from entering the living space. Our range of filter options, up to and including F7, ensure that even homes in heavily urbanised areas have the opportunity to filter out the impurities and help protect their family from respiratory issues.

Nuisance noise – There isn't any...

The most common concern with home owners is that ventilation devices create noise. With Advance, absolute optimisation of every element does everything possible to minimise generation and transmission of both motor and airflow noise. We believe that we have one of the quietest units available.

Ventilation how you want it

We have spent our time considering every element of the ventilation control. Should you want to run the system at certain times and at certain speeds, all of the options are available for you. With a programmable controller, it is possible to boost the unit if required, for example during hot periods in the summer, or even reduce the speed if needed, perhaps when a baby is due to go to bed. Whatever the situation, Advance can be made to operate as needed.

At the same time, automatic functions such as frost protection and summer bypass even have a choice of algorithms designed to suit different climates and lifestyles.

Controllability

With building services often hidden away in cupboards or in lofts we have developed a number of options for system control. From an App which provides instant access wherever you are, to full on-board touch screen controls, an option will be available to support your needs.

SEC Rating

Model	SEC Class
Advance S/SX	A+

Model

Model	Stock Ref
Advance S	405215
Advance SX	405216

Accessories

Model	Stock Ref
Wifi Controller	409195

Spigot Configuration

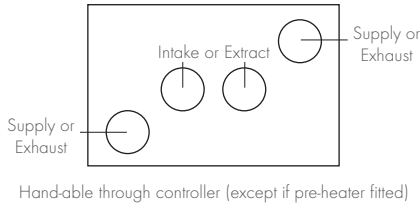

Spigot Configuration

Models	Advance S	Advance SX
Sentinel Touch Screen Controller	✓	✓
App Control	○	✓
App Commissioning	○	✓
Auto 100% Summer Bypass	✓	✓
Easy Access Filters	✓	✓
G3 Filter	✓	✓
M5, F7 Filter Options	✓	✓
Very Low Noise Levels	✓	✓
Built-In Humidistat	✓	✓
Active Frost Protection to -20C	✓	✓
Delay-On	✓	✓
Clean Filter Indicator (Time)	✓	✓
Clean Filter Indicator (Pressure)	X	✓
Fault Code Indicator	✓	✓
Switched Live	✓	✓
Volt Free	✓	✓
OV - 10V Proportional Control	✓	✓
BMS Input/Output	X	✓
Lightweight	✓	✓
22mm or 32mm Condensate Connection	✓	✓
Left/Right Orientation Through Control	✓	✓
Ventwise Control	○	○
PIN Number Lock	✓	✓
Running Time Indicator	✓	✓
Pre-Heater Controller	○	○
Post-Heater Controller	○	○
Enthalpy Heater Exchanger	○	○
Fan Curve Flow	✓	✓
Constant Volume	X	✓
Constant Pressure	X	✓
Email/Text Status Notifications	X	✓
Soft-Start Boost	✓	✓

Mounting Options

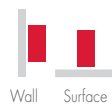

○ - Optional extra contact us for more information

SAP PCDB Test Results

	Thermal Efficiency %	SFP (W/l/s)
K+1	93	0.38
K+2	93	0.38
K+3	92	0.42
K+4	92	0.50
K+5	91	0.58
K+6	91	0.68
K+7	90	0.82

Dimensions (mm)

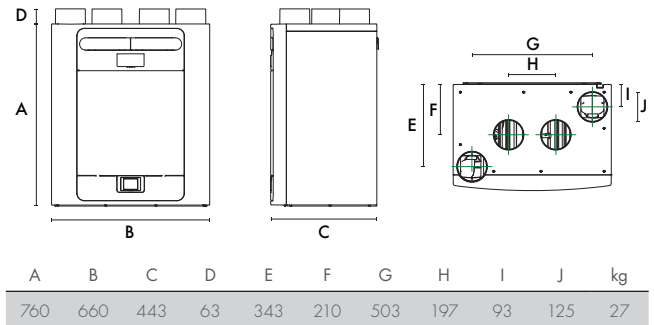

Maximum Airflow

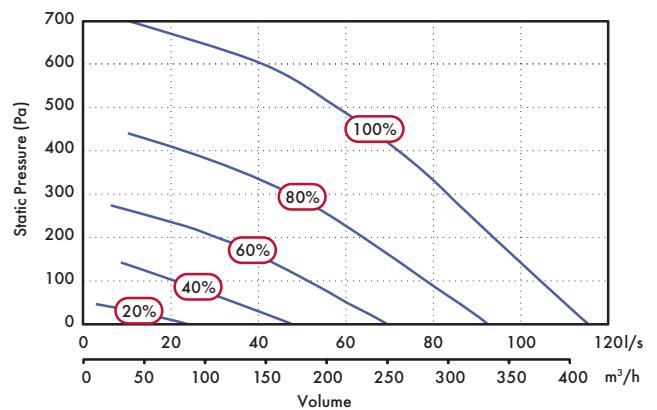

Sound Spectrum

Speed	Test mode	63	125	250	500	1k	2k	4k	8k	SPL dB(A) @ 3m
100%	Extract	72.4	70.5	60.5	56.4	49.8	46.3	39	33.4	42.0
	Supply	79.4	69.6	66.6	75.1	64.9	63.6	53.4	45.7	56.2
	Breakout	64.9	54.4	51.4	57.8	46.2	43.8	39.7	36.9	35.6
80%	Extract	75.5	68.6	59.3	56	48.3	44.2	36.9	31.3	41.1
	Supply	82.4	67.6	65.2	67.6	64.2	60.8	50.8	43.2	51.7
	Breakout	58	56.3	50.4	62	44.8	42.1	38.1	35.3	38.7
60%	Extract	60.6	60.3	54.2	49.5	44.4	36.2	27.9	26.3	34.2
	Supply	66.9	62.4	63.3	62	57.9	53.5	43.4	34.2	45.7
	Breakout	60.2	49.5	48.2	47.4	40.2	35.7	33.3	28.7	27.1
40%	Extract	51.9	51.3	50.4	41.2	35	25.3	19.8	25.4	27.3
	Supply	59.5	56.5	59.4	55	48.2	42.6	31.8	26.1	38.4
	Breakout	42.6	39.2	43.9	39.2	31.5	26.3	24.1	22	19.5
20%	Extract	50.3	49	36	31.5	23.6	16.1	18.9	25.3	18.9
	Supply	52.9	50.9	46.8	43	34.6	27.1	19.2	25.4	26.4
	Breakout	30.7	28.3	32.2	26.9	18.6	15.3	17.9	21.5	8.4

Tested according to BS848. Breakout quoted spherical. Supply and Extract quoted hemispherical.

Lo-Carbon Sentinel Kinetic Range Overview

Features & Benefits

- Manufactured in the UK
- Building Regulations ADF and ADL compliant
- Recognised in SAP PCDB
- Specific Fan Power down to 0.4 W/l/s
- Up to 94% heat recovery
- Fully automatic Summer bypass
- Horizontal and/or vertical duct outlets
- Integrated digital controller for simple and accurate commissioning
- Lightweight for easy installation
- External condensate connection
- Plug and play controls; Humidistat, Ventwise, Wireless Remote

The Sentinel Kinetic Range Incorporates:

- A wholehouse heat recovery system with up to 94% energy efficiency
- An easily accessible heat recovery cube protected by two removable G3 filters
- Two Lo-Carbon energy saving EC/DC fans which ensure long life (typically over double the life of AC motors) and lowest possible energy use
- Fully insulated construction with built-in condensation drain
- Specifically designed for new build constructions with a high level of insulation

The Lo-Carbon Sentinel Kinetic meets the latest requirements of the Building Regulations ADF and ADL for wholehouse system ventilation: System 4 - Continuous mechanical supply and extract with heat recovery. The Lo-Carbon Sentinel Kinetic models have 3 fully adjustable speeds and a purge setting (maximum flow). Provided with the unit is a digital controller that can be used to preset the speeds to any required airflow within the performance range.

Integral Humidity Sensor

The integral humidity sensor (models with H suffix) increases speed in proportion to relative humidity levels, saving energy and reducing noise. The sensor also reacts to small but rapid increases in humidity, even if the normal trigger threshold is not reached. This unique feature ensures adequate ventilation, even for the smallest wet room. The night time relative humidity setback feature suppresses nuisance tripping as humidity gradually increases with falling temperature.

Optional M5 Supply Filters

Kinetic B, BH & Cooker Hoods Filter

Stock Ref

444199

Kinetic Plus Range Filter

Stock Ref

444201

For sensors see Accessories & Controllers section.

Sentinel Control

The Sentinel controller is the most advanced system available, providing Demand Control Ventilation (DCV), minimising energy consumption and noise levels, and optimising ventilation performance. Sentinel controlled units may be set to operate fully automatically or with varying levels of manual intervention.

Building Management System (BMS) Options

There are two levels of BMS available: Basic Output and full Electronic BMS.

Basic Output provides a 5 volt output from the LED terminals on the controller. This output occurs whenever a message appears in the digital display, for example; 'Check Filters' or a fault code. The output can also be converted to volt-free with the addition of an optional Opto-Coupler.

Electronic BMS: A full range of two-way digital signals are available through the RJ11 connector on the control board. The BMS system provider will translate this signal to extract the desired data. Contact Vent-Axia to discuss your specific requirements.

LED Alarm

MVHR units are often installed in lofts or other locations where they are difficult to monitor. The optional remote LED alarm illuminates when any message is visible in the MVHR unit display panel. The LED alarm can be installed in a convenient location within the dwelling allowing end users to see that the unit requires attention.

Control Inputs

Five volt-free pairs of switch terminals for sensor inputs allow boosting from a full range of Vent-Axia controllers - humidistats, PIR, timers.

Two terminals with 0-24V outputs allow 0V to 10V proportional control by sophisticated controllers such as CO₂ sensors and proportional humidistats.

The optional Ventwise controller senses temperature rise in a bath/shower hot water supply and/or current in a cooker/hob electrical circuit to activate boost, ensuring additional ventilation when needed.

Switched-live for boosting via light switches (220-240 V AC) or manual Normal/Boost switches. This connection has the advantage of Delay-On and Delay-Off facility. Delay-On enables you to prevent the Boost airflow between 0 and 10 minutes, after a light switch has been activated. Delay-Off allows the Boost airflow to continue after a light switch is turned off to ensure effective clearance of humidity. This timer is adjustable between 0 and 25 minutes.

The units can be boosted incrementally via the on-board controller or the Wired Remote Controller: One press = 30 minutes, two presses = 60 minutes, three presses = continuous.

Optional Controls

LED Alarm with 15 metre cable

Stock Ref

448356

Wired Remote Controller with 15 metre cable

Stock Ref

443283

Wireless Enable Kit (includes one switch)

Stock Ref

441865

Additional Wireless Boost Switch

(max 3 switches)

Stock Ref

437827

Ventwise Controller (also requires sensors, see Accessories & Controllers section)

Stock Ref

441780

Purge Setting

The unit can be set to maximum flow (100%) by pressing and holding the Boost button on the unit itself or optional wired controller for 5 seconds. Purge will continue for two hours unless cancelled by pressing the Boost button again.

Summer Bypass

An internal damper operates when the external temperature is below the internal temperature, and the internal temperature is too high.

The bypass opens and allows the cooler outside air to help cool the dwelling.

Normal mode: Fans run on Normal speed with bypass open until the internal dwelling temperature falls below the set 'Indoor' (maximum desired) temperature.

Evening Purge mode: The fans run on Boost speed until the internal temperature falls below the set 'Indoor' temperature. If, after five hours the internal temperature is still above the set 'Indoor' temperature, the unit will switch down to normal speed for the remainder of the 'bypass open' period.

Night-time Purge mode: As Evening Purge, except that the unit will continue on Boost speed until the internal air temperature reaches the 'Outdoor' temperature set point (Default 14°C). This mode gives pre-cooling of the dwelling for the following day.

In Evening and Night Time Purge modes, the user can turn off the boost function by pressing the Boost button.

Frost Protection

In order to prevent frost forming inside the unit in winter conditions, the Kinetic range employs a sophisticated frost protection strategy that modifies the airflows ensuring heat recovery continues down to -20°C. Below this temperature, the units will operate as 'extract only' fans. If balanced ventilation is required at low temperatures, a duct pre-heater should be used.

System Cooker Hood Range

System canopy hoods are a motorless hood with extract being provided by the MVHR unit. When the Boost button on the canopy is activated, the MVHR unit goes to boost setting and the summer bypass opens preventing cooking by-products entering the heat exchanger cell.

White Pull-out System Hood

Stock ref

407509

Aluminium Pull-out System Hood

Stock ref

407206

Wired Remote Controller

Standard with horizontal units, optional extra with vertical units. Supplied with 15 metres of cable (max length), the Wired Remote Controller duplicates all the features of the on-board control panel, allowing commissioning, diagnosis and user control. Flush mounting, suitable for a single gang pattress box 16mm deep.



Model Range Overview

Sentinel Kinetic Range

Kinetic E Range



Model Ranges	Lo-Carbon Sentinel Kinetic			Lo-Carbon Sentinel Kinetic F	Lo-Carbon Sentinel Kinetic Plus	Lo-Carbon Sentinel Kinetic High Flow	Lo-Carbon Sentinel Kinetic Cooker Hood	Lo-Carbon Sentinel Kinetic Horizontal			Lo-Carbon Kinetic Plus E			
	V	B	BH	F	Plus	High Flow	CH	200ZP/ZPH	300ZH	200Z/ZH/ZMH*	Plus E			
Auto Summer Bypass		✓	✓	✓	✓	✓	✓	✓	✓	✓	✓			
Easy Access Filters	✓	✓	✓	✓	✓	✓	✓	✓	✓	✓	✓	✓		
Very Low Noise Levels	✓	✓	✓	✓	✓	✓	✓	✓	✓	✓	✓	✓		
Integral Cooker Hood							✓							
Built-In Humidistat			✓	✓	✓	✓	✓	✓						
Kitchen Cupboard Installation	✓	✓	✓											
Max Airflow @ 100Pa	68	68	68	79	117	117	68	34	81	50	117			
Frost Protection	✓	✓	✓	✓	✓	✓	✓	✓	✓	✓	✓	✓		
Delay-On	✓	✓	✓	✓	✓	✓	✓	✓	✓	✓	✓	✓		
Wired Remote Control	○	○	○	○	○	○	○	✓	✓	✓				
Wireless Boost	○	○	○	○	○	○	○	○	○	○				
Clean Filter Indicator (Time)	✓	✓	✓	✓	✓	✓	✓	✓	✓	✓	✓	✓		
Fault Code Indicator	✓	✓	✓	✓	✓	✓	✓	✓	✓	✓	✓	✓		
Potentiometer Control												✓		
Sentinel Control	✓	✓	✓	✓	✓	✓	✓	✓	✓	✓	✓	✓		
Switched Live	✓	✓	✓	✓	✓	✓	✓	✓	✓	✓	✓	✓		
Volt Free Contact	✓	✓	✓	✓	✓	✓	✓	✓	✓	✓	✓	✓		
OV - 10V Proportional Control	✓	✓	✓	✓	✓	✓	✓	✓	✓	✓	✓	✓		
BMS Input/Output	✓1	✓1	✓1	✓1	✓1	✓1	✓1	✓1	✓1	✓1	✓1	✓1		
Lightweight	✓	✓	✓	✓	✓	✓	✓					✓		
External Condensate	✓	✓	✓	✓	✓	✓	✓	✓	✓	✓	✓	✓		
Horizontal Duct Option	✓	✓	✓	✓	✓	✓	✓	✓	✓	✓	✓	✓		
Horizontal (Slab) Installation								✓	✓	✓				
Left/Right Orientation	✓	✓	✓	✓	✓	✓	✓					✓		
Ventwise Control	✓	✓	✓	✓	✓	✓	✓	✓	✓	✓	✓	✓		
PIN Number Lock	✓	✓	✓	✓	✓	✓	✓	✓	✓	✓	✓	✓		
Running Time Indicator	✓	✓	✓	✓	✓	✓	✓	✓	✓	✓	✓	✓		
Enthalpy Heater Exchanger		○	○	○	○	○	○							
Mounting Options	 Wall Surface		 Wall Surface		 Wall Surface		 Wall Surface		 Wall		 Slab		 Wall Surface	

○ - Denote Optional, 1- Seek technical advice from Vent-Axia. *ZMH rectangular spigot model.

Sentinel Demand Control

The Lo-Carbon Sentinel Kinetic Range can be used with a wide range of optional Vent-Axia controllers and sensors. Ranging from integral humidistats, through wireless controllers to wired remote sensors.

Wired Remote Controller

- Standard with horizontal units, optional extra with vertical units
- Supplied with 15 metres of cable (max length), the Wired Remote Controller duplicates all the features of the on-board control panel, allowing commissioning, diagnosis and user control
- Flush mounting, suitable for a single gang pattress box 16mm deep

Stock Ref

443283



Wireless Transmitter Controller Receiver Kit

- Manual boost
- Adjustable overrun timer
- Easy wireless installation
- Reduces installation time
- Future proof - add more controllers at any time

Stock Ref

441865



Wireless Transmitter Controller

- Additional controller for 441865
- A maximum of 4 controllers can be used per system
- Can be connected to other accessories (eg Humidistat) to send a boost signal wirelessly

Stock Ref

437827



Ambient Response Humidity Sensor

- Pullcord override and neon indicator
- Changeover relay switch
- Operating range: 30% - 90%RH
- Ambient operating temp. 5°C to 40°C
- 220-240V AC
- Will fit single gang box for surface mounting

Stock Ref

563550



Ecotronic Humidity Sensor

- Set Point adjustable
- Maximum switching load 1 amp inductive
- Pullcord override indicator
- Ambient operating temp. 0°C to 40°C
- Supply voltage 220-240V

Stock Ref

563532



Air Quality Sensor

- Ambient operating temp. 0°C to 50°C
- Min - Max mode or direct damper control
- Surface mounted
- 1 - 25 min O/R timer
- Supply voltage 220-240V

Stock Ref

563506



Normal Boost Switch

- A single gang switch to boost from low to high speeds on heat recovery systems
- 85 x 85 x 10mm (H x W x D)

Stock Ref

455213



Visonex PIR Sensor

- Fits any UK single gang mounting box
- Adjustable timer overrun (5-25 mins)
- Range of detection up to 10 metres
- Designed to meet IP43
- Ambient operating temp. range 0°C to 50°C

Stock Ref

459623



CO₂ + Temp Room Sensor

- 240V DC
- 0 - 2000ppm CO2 working range
- 0 - 50°C working range
- Auto-calibrating NDIR CO22
- Thin film platinum temperature sensor for high accuracy

Stock Ref

433257



Ventwise

- Automatically boosts fan when temperature of the supply pipe to a shower or bath increases
- Automatically boosts fan when electric hob is switched on
- Can be used in conjunction with manual override input
- Adjustable overrun timer
- 3 sensor inputs

Stock Ref

441780



Momentary Push Switch

- Compatible with Sentinel Kinetic range, the momentary switch boosts the unit for 30 minutes
- 85 x 85 x 10mm (H x W x D)

Stock Ref

448929



Normal Boost Switch with Light Indicator

- Single gang switch with LED illumination when in the Boost condition
- 85 x 85 x 10mm (H x W x D)

Stock Ref

449060



Normal Boost Switch - Stainless Steel

A single gang switch to operate normal/boost functions on MVHR systems

- Brushed stainless steel finish
- 90 x 90 x 18 (H x W x D)

Stock Ref

437320



Isolator Relay Controller

- Allows fan unit to be isolated from other mains circuit when used with TIM2 trickle/boost switch or light switch control

Stock Ref

442030



Lo-Carbon Sentinel Kinetic

Features & Benefits

- Recognised in SAP PCDB
- Ultra quiet
- Lightweight for easier installation
- Horizontal duct option for space-saving installations
- Fits within a 290mm deep kitchen cupboard (B & BH)
- Integrated digital controller for simple and accurate commissioning
- Plug and play controls; Humidistat, Ventwise, Wireless Remote
- BMS connectivity
- LS inputs (Light Switch)
- Horizontal duct options



Easy Installation

The Sentinel Kinetic models can be mounted vertically in a roof space, hallway cupboard or kitchen or within a kitchen cupboard. When mounted in an unheated area ducting should be insulated. Ducting can be attached to the unit horizontally, vertically or both. Minimum internal depth of kitchen cupboard: V, B & BH models 290mm.

Left (L) or right (R) hand installation. The unit is supplied with duct spigots to outside on the right hand side. These can be reversed on site by simply removing the control panel, rotating the unit 180 degrees and re-attaching the control panel.

Spigot Options

The combination of spigot options allows installation in confined locations. If vertical and horizontal connection is required on the same outlet/inlet, additional spigots can be supplied.

The condensate drain can be taken out through the back, side or bottom of the unit. Using the fittings supplied, the final condensate connection is made outside the unit and can be completed after installation.

Integral Humidity Sensor (BH Models)

The integral humidity sensor increases speed in proportion to relative humidity levels, saving energy and reducing noise. The sensor also reacts to small but rapid increases in humidity, even if the normal trigger threshold is not reached. This unique feature ensures adequate ventilation, even for the smallest wet room. The night time relative humidity setback feature suppresses nuisance tripping as humidity gradually increases with falling temperature.

Models

Model	Stock Ref
Kinetic V	438342
Kinetic B Right	438222
Kinetic B Left	438222L

(with summer bypass)

Kinetic BH Right	443319
Kinetic BH Left	443319L

(with summer bypass & humidity sensor)

B & BH models available in left hand or right hand configurations (L).

Accessories

Model	Stock Ref
Wired Remote Controller	443283
Wireless Enable Kit	441865
Wireless Transmitter	437827
Controller	
Ventwise Controller	441780
LED alarm with 15m cable	448356

Kinetic V, B & BH	Stock Ref
Kinetic Spare Filter 2 pk	442356
M5 Pollen Filter	444199

SAP PCDB Test Results (Kinetic V)

	Thermal Efficiency %	SFP (W/l/s)
K+1	90	0.60
K+2	90	0.59
K+3	90	0.68
K+4	89	0.79
K+5	90	0.97

SEC Rating

Model	SEC Class
Kinetic V/B/BH	A

Dimensions (mm)

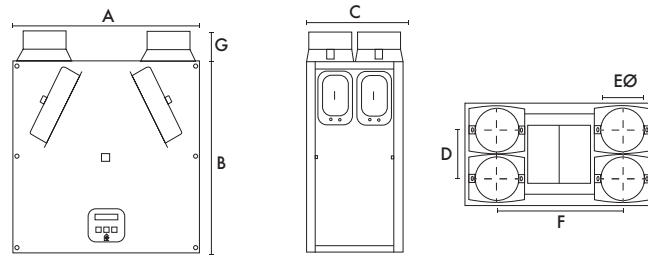

A	B	C	D	EØ	F	G
550	550	285	140	125	360	90

Weight: 15kg

Performance

Fan speeds are fully adjustable within the performance range.

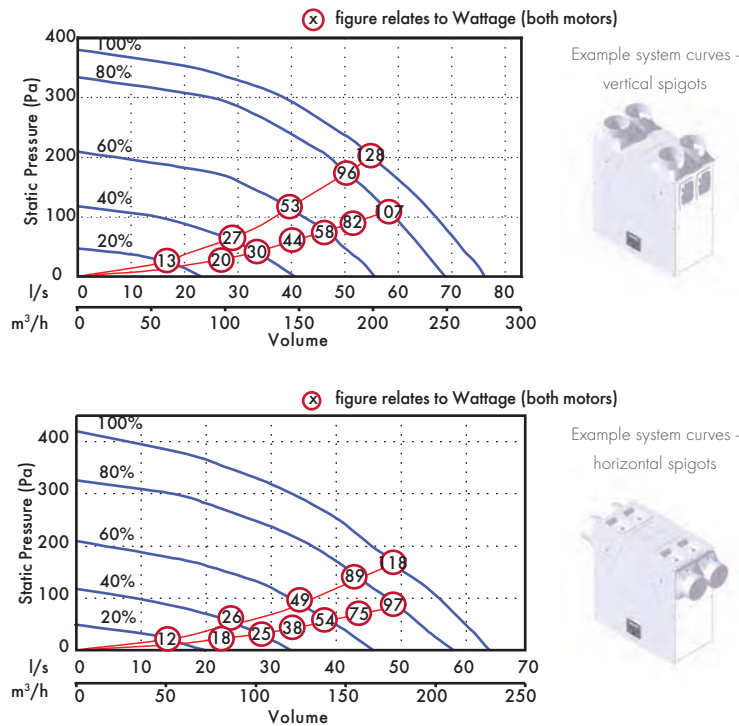

Sound Data (Kinetic B & V)

Flow l/s	Test mode	Octave band, Hz, dB SWL								SPL dB(A) @ 3m
		63	125	250	500	1K	2k	4K	8K	
10	Supply	47.8	40.2	38	31.1	28.2	22.1	23.6	30.9	21.4
	Extract	47	38.7	36	29.9	25	22.4	23.3	30.8	20.6
	Breakout	43.6	36.2	37.4	30.9	27.4	23.3	24.2	31.4	18.6
20	Supply	54	46.6	50.2	44.5	44.4	38.3	28.8	31.9	31.2
	Extract	46.8	40.5	34.6	34.2	34.6	25.9	23.7	30.3	22.9
	Breakout	45.9	39.9	40.6	35.7	33.5	28.4	25.3	31.2	21.3
30	Supply	58.1	54.5	57.6	52.2	51.7	47.6	38.6	35.8	38.5
	Extract	47.6	46.2	38.7	41.3	42.8	33.9	26.4	30.5	28.4
	Breakout	45.2	42.4	48.2	40.8	37.7	35.2	30	31.1	25.2
40	Supply	65.2	58.4	62.3	58	56.5	52.5	44.1	41.4	43.6
	Extract	53.5	53	44	47.7	48.1	39.7	31.5	31.5	33.5
	Breakout	50.9	47.6	47.4	48.1	42.5	40.8	36.3	34.4	29.3
50	Supply	66.4	63.2	66.3	62.5	61.7	57.4	50	47.8	48.3
	Extract	64.2	55.2	48	50.9	52.1	44.5	35.9	35	37.2
	Breakout	55	51	51.3	51.6	46.9	46.0	42	38.3	33.2

Tested according to BS848. Breakout quoted spherical. Supply and Extract quoted hemispherical.

Consultant's Specification (B and BH Models)

Operation

The supply and extract ventilation unit shall be a Sentinel Kinetic as manufactured by Vent-Axia and shall be sized as indicated on the drawings and shall be in accordance with the particular specification.

Supply air to the room shall be pre-heated by the extract air via the integrated composite plastic counterflow heat recovery cell. The Sentinel Kinetic shall automatically vary the ventilation rate via EC/DC motors, as it receives signals from one of the optional interconnected sensors. When a signal is received, the fans shall either vary their speed proportionally or on a trickle and boost principle.

The unit shall have the facility to commission the supply and extract fans individually via in-built minimum and maximum speed adjustment, or alternative wired remote control unit. The fans themselves shall have independent, infinitely variable speed control.

Unit Specification

The unit shall be manufactured with an ABS outer case construction, and incorporate a reversible core to allow for left or right hand mounting.

The unit shall have a high efficiency composite plastic counterflow heat exchanger, supply and extract filters, automatic summer bypass, (B/BH) integral minimum and maximum infinitely variable speed controls with facia mounted failure indication. The unit shall have low energy, high efficiency EC/DC fan/motor assemblies with sealed for life bearings. The impellers shall be high efficiency forward curved centrifugal type.

The unit shall have a heat exchanger cell with a thermal efficiency of up to 92% when tested to EN 308. This shall be protected by G3 grade synthetic filters on supply and extract. Complete with a condensate drip tray and drain connection.

The unit shall be constructed with a removable Core allowing full maintenance access. The removable Core shall provide access to the following:

- ✓ Supply and extract filter
- ✓ Heat exchanger
- ✓ Access to the electrical connections

Access shall be provided for wiring termination and setup/commissioning. The backlit LCD user interface therein shall be removable for remote mounting if required.

Units shall be as manufactured by Vent-Axia Ltd.

Standard Controls

All Sentinel Kinetic units shall incorporate the following functions integrally mounted, pre-wired and factory fitted by the manufacturer:

- ✓ Integral infinitely variable fan speed control on supply and extract
- ✓ Integral min/max ventilation control/set point
- ✓ Integral BMS interfaces - control and status indication
- ✓ Heating interlocks
- ✓ 0-10V proportional speed adjustment
- ✓ Volt free contacts
- ✓ 24V sensor supply
- ✓ Integral on/off or trickle boost function from remote switch e.g. PIR occupancy detector
- ✓ The unit shall be controlled by the 'Sentinel' control devices (enablers and sensors) as detailed in the schedule or on the drawings
- ✓ Fully automatic summer bypass
- ✓ Switched Live input with adjustable 'delay-on' feature

- ✓ Fan failure or component failure indicated via individual fault code display
- ✓ Running time counter
- ✓ Control panel PIN number lock
- ✓ Automatic frost protection effective to -20°C
- ✓ Tool free filter access
- ✓ The unit shall incorporate ('H' models) an integral humidity sensor with the following features:
 - Ambient Response; Raises the humidity trigger point as dwelling temperature reduces
 - Rapid Response; Monitors the rate of change in humidity and triggers increased airflow even if the humidity trigger threshold is not reached
 - Proportional Response; Incrementally increases the fan speed to reduce noise and reduce energy consumption

Mounting Option

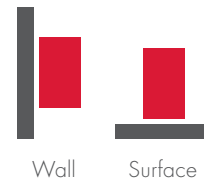

Airflow Direction

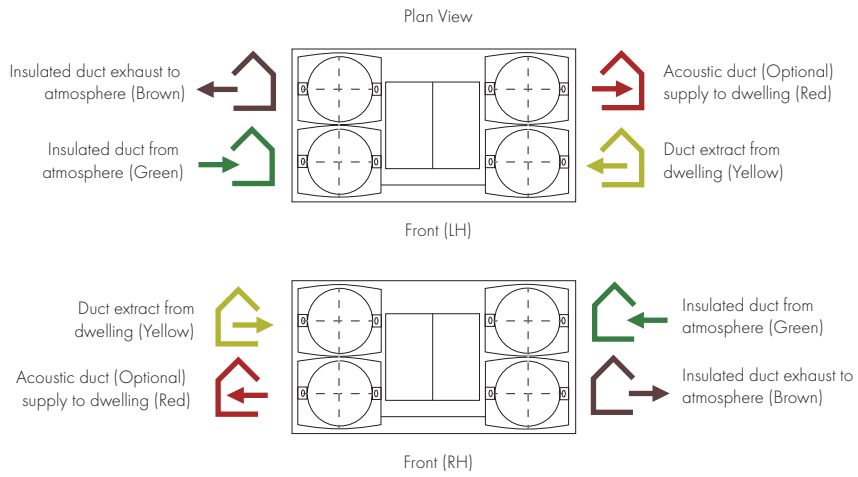

Electrical Connection (B and BH Models)

Please note: Electrical connection should be carried out by an appropriately qualified person and in accordance with current wiring regulations.

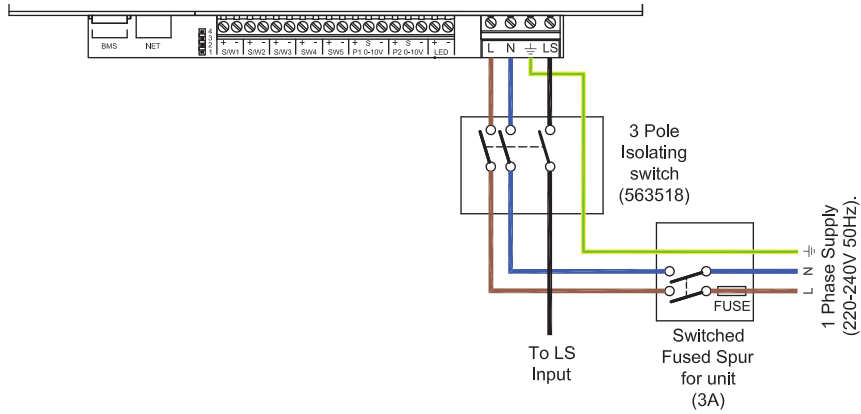

Trickle to Boost by Trickle/Boost switch

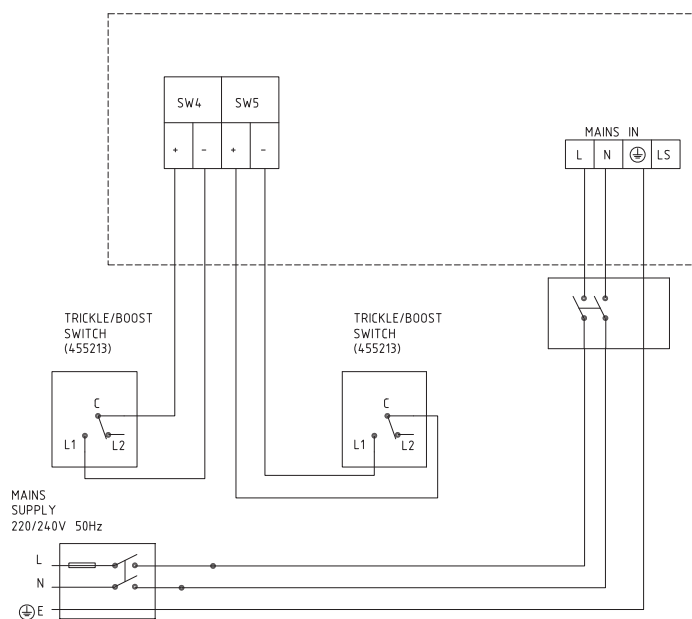

Lo-Carbon Sentinel Kinetic FH

Features & Benefits

- Ultra quiet
- Lightweight for easier installation
- Horizontal duct option for space-saving installations
- Integrated digital controller for simple and accurate commissioning
- Plug and play controls; Humidistat, Ventwise, Wireless Remote
- BMS connectivity
- LS inputs (Light Switch)
- Volt-free inputs
- Self diagnosis for simplified fault finding
- Adjustable delay On/delay Off timer



Easy Installation

The Sentinel Kinetic models can be mounted vertically in a roof space or in an appropriate cupboard within the dwelling. When mounted in an unheated area the ducting and unit must be insulated in accordance with the Domestic Ventilation Compliance Guide. Ducting can be attached to the unit horizontally, vertically or both.

Left (L) or right (R) hand installation. Left hand and right hand units are available.

Spigot Options

The combination of spigot options allows installation in confined locations. If vertical and horizontal connection is required on the same outlet/inlet, additional spigots can be supplied.

The condensate drain can be taken out through the back, side or bottom of the unit. Using the fittings supplied, the final condensate connection is made outside the unit and can be completed after installation.

Integral Humidity Sensor

The integral humidity sensor increases speed in proportion to relative humidity levels, saving energy and reducing noise. The sensor also reacts to small but rapid increases in humidity, even if the normal trigger threshold is not reached. This unique feature ensures adequate ventilation, even for the smallest wet room. The night time relative humidity setback feature suppresses nuisance tripping as humidity gradually increases with falling temperature.

Model

Model	Stock Ref
Kinetic FH Right (right handed with summer bypass & humidity sensor)	408167
Kinetic FHL Left (left handed with summer bypass & humidity sensor)	408169

Accessories

Model	Stock Ref
Wired Remote Controller	443283
Wireless Enable Kit	441865
Wireless Transmitter Controller	437827
Ventwise Controller	441780
LED alarm with 15m cable	448356
Kinetic Spare Filter 2pk	409158

SAP PCDB performance

	Thermal	
	Efficiency %	SFP (W/l/s)
K+1	90	0.53
K+2	89	0.51
K+3	88	0.56
K+4	87	0.65
K+5	85	0.75

SEC Rating

Model	SEC Class
Kinetic FH/FHL	A+

Dimensions (mm)

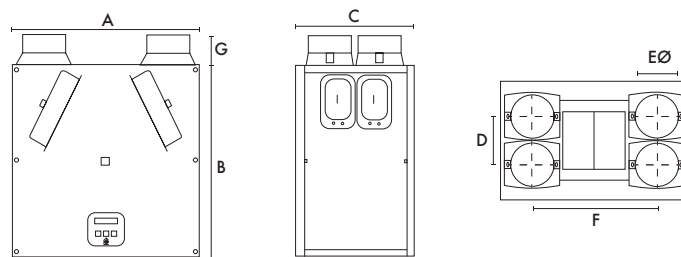

A	B	C	D	EØ	F	G
555	550	350	140	125	360	90

Weight: 18kg

Performance

Fan speeds are fully adjustable within the performance range.

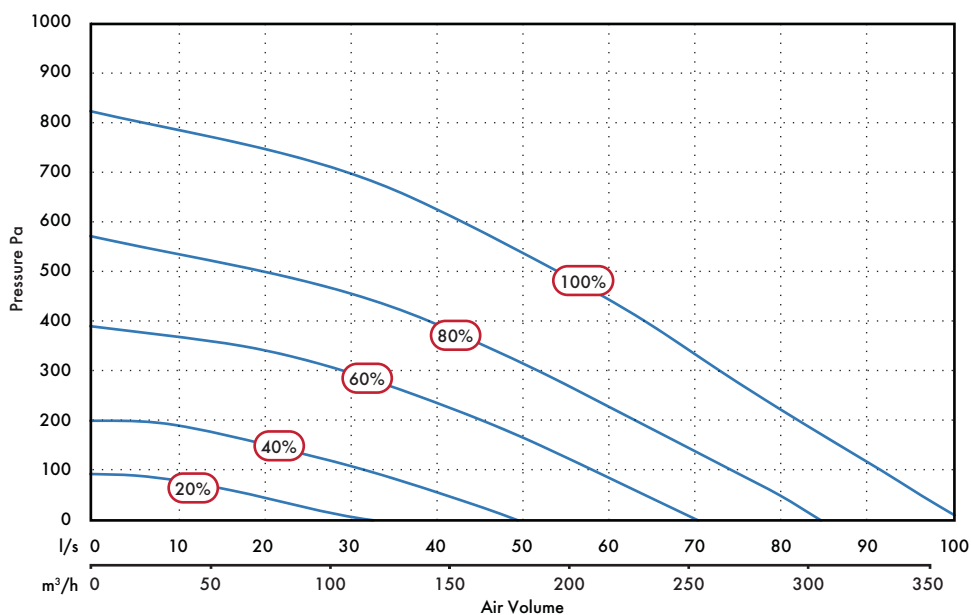

Sound Data

Speed	Port	Octave band, Hz, dB SWL								SPL dB(A) @ 3m	
		Test mode	63	125	250	500	1k	2k	4k		8k
100%	Extract		83.3	68.3	66.9	71.2	60.7	51.4	42.4	36.1	52.2
	Supply		95.5	77.7	74	80.4	68.7	62.9	56.9	52.4	61.6
	Breakout		62.1	59.7	62.9	70	61	57.3	52.3	46.9	47.5
80%	Extract		83.5	65.2	65	65.5	57	47.7	37.9	31.3	48
	Supply		85	75.3	72.5	77.9	65.3	58.8	52.1	47.4	58.5
	Breakout		56.4	56.4	60.4	69.8	56.7	53.2	47.8	42	46
60%	Extract		67.3	61.9	66.5	58.9	52.2	42.7	32.6	27.6	43.6
	Supply		72.8	72.5	82.2	64.4	59.9	53.8	46.2	40.3	56.9
	Breakout		53.9	53.2	65.9	55.8	52.2	48.2	42.5	39.3	40.5
40%	Extract		66.8	56.1	56.9	52.1	44.7	34.6	23.8	25.8	35.7
	Supply		68.9	66.4	68.8	57.8	52.1	44.9	35.3	28.8	44.9
	Breakout		47.3	47.5	56.4	48	44	39.6	32.8	29.1	30.5
20%	Extract		57.7	56.6	47.2	43.5	35.3	24.1	19.6	25.7	28.2
	Supply		66.2	67.2	54.3	48	42.1	33.3	22.5	25.6	36.4
	Breakout		41.2	47	41.7	39.5	34.6	30.4	22.5	25.7	20.5

Tested according to BS848. Breakout quoted spherical. Supply and Extract quoted hemispherical.

Consultant's Specification

Operation

The supply and extract ventilation unit shall be a Sentinel Kinetic as manufactured by Vent-Axia and shall be sized as indicated on the drawings and shall be in accordance with the particular specification.

Supply air to the room shall be pre-heated by the extract air via the integrated composite plastic counterflow heat recovery cell. The Sentinel Kinetic shall automatically vary the ventilation rate via EC/DC motors, as it receives signals from one of the optional interconnected sensors. When a signal is received, the fans shall either vary their speed proportionally or on a trickle and boost principle.

The unit shall have the facility to commission the supply and extract fans individually via in-built minimum and maximum speed adjustment, or alternative wired remote control unit. The fans themselves shall have independent, infinitely variable speed control.

Unit Specification

The unit shall be manufactured with an ABS outer case construction, and incorporate a reversible core to allow for left or right hand mounting.

The unit shall have a high efficiency composite plastic counterflow heat exchanger, supply and extract filters, automatic summer bypass, integral minimum and maximum infinitely variable speed controls with fascia mounted failure indication. The unit shall have low energy, high efficiency EC/DC fan/motor assemblies with sealed for life bearings. The impellers shall be high efficiency backward curved centrifugal type.

The unit shall have a heat exchanger cell with a thermal efficiency of up to 90% when tested to EN 308. This shall be protected by G3 grade synthetic filters on supply and extract. Complete with a condensate drip tray and drain connection.

The unit shall be constructed with a removable Core allowing full maintenance access. The removable Core shall provide access to the following:

- ✓ Supply and extract filter
- ✓ Heat exchanger
- ✓ Access to the electrical connections

Access shall be provided for wiring termination and setup/commissioning. The backlit LCD user interface therein shall be removable for remote mounting if required.

Units shall be as manufactured by Vent-Axia Ltd.

Standard Controls

All Sentinel Kinetic units shall incorporate the following functions integrally mounted, pre-wired and factory fitted by the manufacturer:

- ✓ Integral infinitely variable fan speed control on supply and extract
- ✓ Integral min/max ventilation control/set point
- ✓ Integral BMS interfaces - control and status indication
- ✓ Heating interlocks
- ✓ 0-10V proportional speed adjustment
- ✓ Volt free contacts
- ✓ 24V sensor supply
- ✓ Integral on/off or trickle boost function from remote switch e.g. PIR occupancy detector
- ✓ The unit shall be controlled by the 'Sentinel' control devices (enablers and sensors) as detailed in the schedule or on the drawings
- ✓ Fully automatic summer bypass
- ✓ Switched Live input with adjustable 'delay-on' feature

- ✓ Fan failure or component failure indicated via individual fault code display
- ✓ Running time counter
- ✓ Control panel PIN number lock
- ✓ Automatic frost protection effective to -20°C
- ✓ Tool free filter access
- ✓ The unit shall incorporate ('H' models) an integral humidity sensor with the following features:
 - Ambient Response; Raises the humidity trigger point as dwelling temperature reduces
 - Rapid Response; Monitors the rate of change in humidity and triggers increased airflow even if the humidity trigger threshold is not reached
 - Proportional Response; Incrementally increases the fan speed to reduce noise and reduce energy consumption

Mounting Option

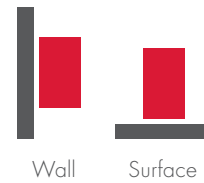

Airflow Direction

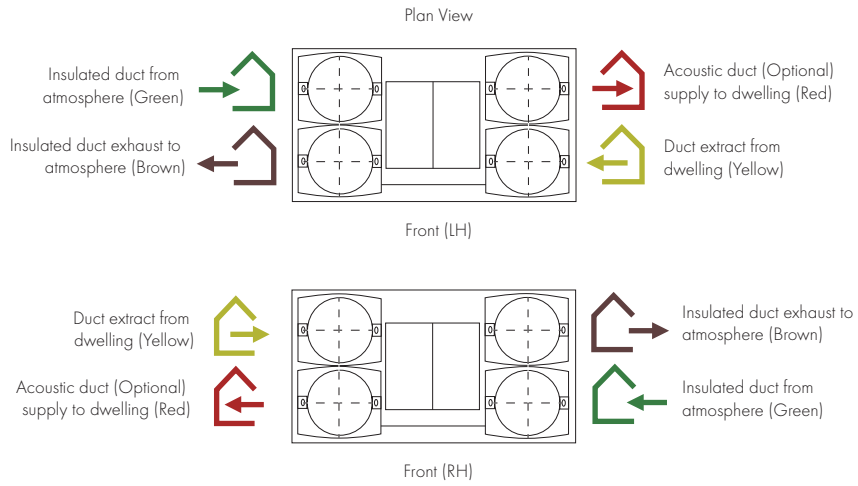

Electrical Connection

Please note: Electrical connection should be carried out by an appropriately qualified person and in accordance with current wiring regulations.

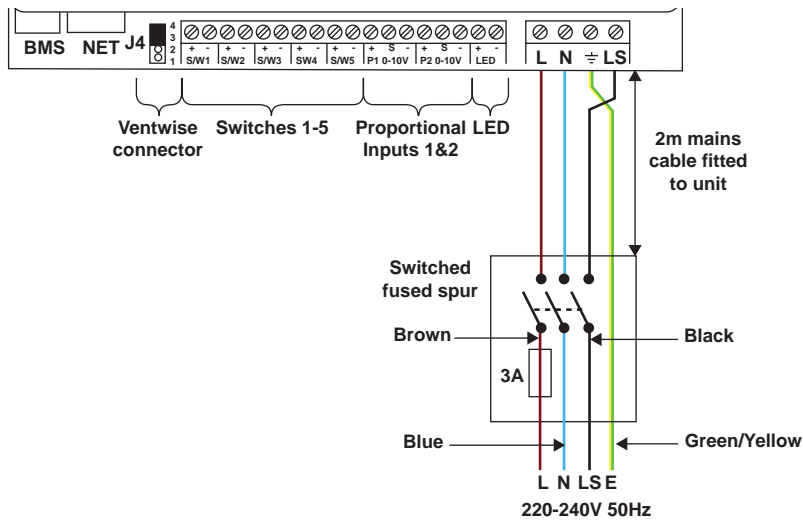

Trickle to Boost by Trickle/Boost switch

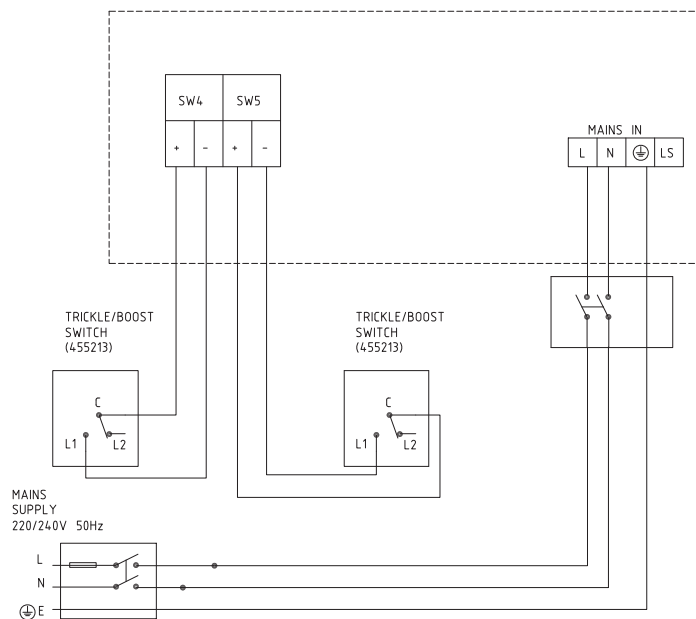

Lo-Carbon Sentinel Kinetic Plus

Features & Benefits

- Recognised in SAP PCDB
- Ultra quiet
- Horizontal duct option for space-saving installations
- High airflow, ideal for student accommodation clusters
- Unique folding filter for removal when access is restricted
- Integrated digital controller for simple and accurate commissioning
- Lightweight for easy installation
- Plug and play controls; Humidistat, Ventwise, Wireless Remote
- BMS connectivity
- LS inputs (Light Switch)
- Volt-free inputs



Increased Performance

The Sentinel Kinetic Plus benefits from the latest high efficiency, backward curved impeller design, ensuring the lowest possible energy consumption, ultra quiet operation and an exceptional performance range covering small one bed apartments to the largest of houses.

Care Homes & Student Accommodation

The Sentinel Kinetic Plus is ideal for larger homes and multiple occupancy units such as care homes and student accommodation. Capable of 400m³/hr at 150Pa, the unit can extract from up to ten bathrooms and a communal kitchen while still achieving almost 90% heat recovery. The fully automatic capability of the Kinetic range means that adequate ventilation is always achieved.

The Kinetic's BMS capability is also ideal for those commercial applications where landlords or property managers want to monitor and optimise building performance and maintenance. The Kinetic BMS can provide status information and its self diagnostics can report if any fault is found.

Spigot Options

Spigots may be re-positioned to give horizontal connection or a combination of vertical and horizontal connection.

Optional 180mm/200mm spigots can simplify connection in commercial installations where larger diameter duct work has been used.

Quick Change Filter

As many systems are placed within cupboards the unique filter design folds as you remove it to ensure easy access in restricted spaces.

Integral Humidity Sensor

The integral humidity sensor increases speed in proportion to relative humidity levels, saving energy and reducing noise. The sensor also reacts to small but rapid increases in humidity, even if the normal trigger threshold

is not reached. This unique feature ensures adequate ventilation, even for the smallest wet room. The night time relative humidity setback feature suppresses nuisance tripping as humidity gradually increases with falling temperature.

Models

Model	Stock Ref
Kinetic Plus B Right	443028
Kinetic Plus B Left	443028L

Accessories

Model	Stock Ref
Wired Remote Controller	443283
Wireless Enable Kit	441865
Wireless Transmitter Controller	437827
Ventwise Controller	441780
LED Alarm with 15m cable	448356
Opto-coupler for volt-free bms connection	447340
Kinetic Spare Filters 2 pk.	443351
M5 Pollen Filter	444201
180mm/200mm Spigot Kit (One per pack)	446523

SAP PCDB Test Results

	Thermal Efficiency %	SFP (W/l/s)
K+1	91	0.51
K+2	91	0.40
K+3	90	0.41
K+4	90	0.45
K+5	90	0.53
K+6	90	0.60
K+7	90	0.70

SEC Class Rating

Model	SEC Class
Kinetic Plus B	A+

Dimensions (mm)

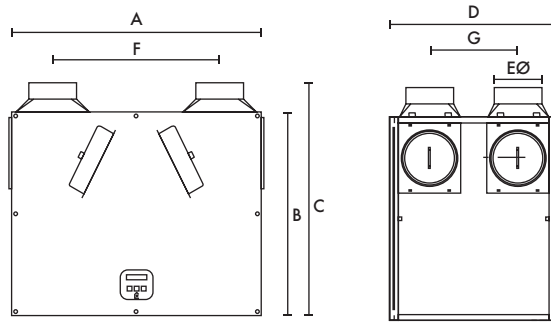

A	B	C	D	EØ	F	G
785	635	722	550	150	520	275

Weight: 24kg

Performance

Fan speeds are fully adjustable within the performance range.

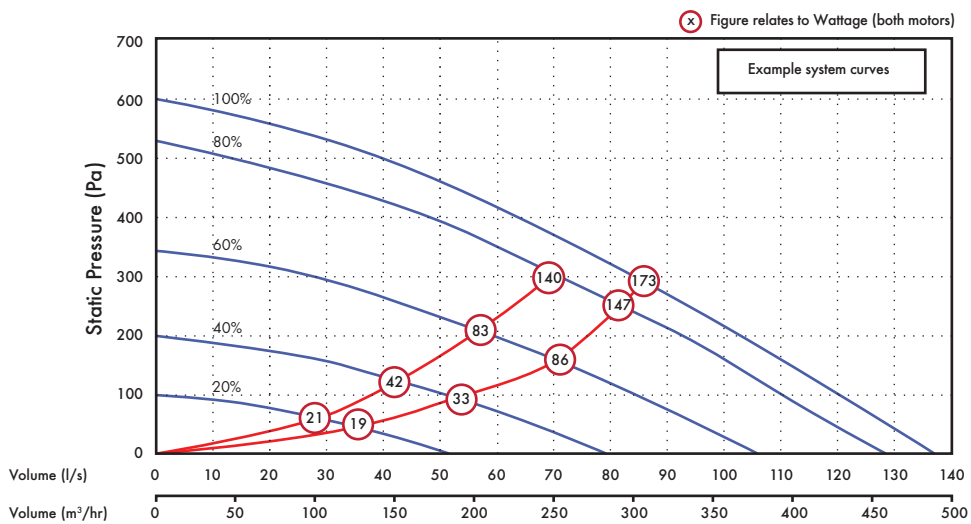

Sound Data

Flow l/s	Unit setting	Test mode	Octave band, Hz, dB SWL								SPL dB(A) at 3m
			63	125	250	500	1k	2k	4k	8k	
50	20%	Supply	46.5	54.3	46.4	44.8	36.2	28.5	24.5	31.2	28.5
		Extract	46	52.2	42.3	38.7	27.6	24.2	24	31.7	25
		Breakout	48.5	42.6	43.3	38.9	35.8	29.3	23.8	30.7	22.8
78	40%	Supply	50.3	59.1	54.5	56.5	47	39.9	26.3	31.7	38
		Extract	46.8	51.6	47.8	44.4	32.7	27.4	24.4	31.7	28
		Breakout	48.4	51.2	53.4	46	41	34.6	25	30.3	28.5
104	60%	Supply	52.4	57.2	60.4	60.9	55.8	50.3	33.1	33.9	43.6
		Extract	50	49.8	56.8	52.4	40.2	35.9	33.4	39.8	35.2
		Breakout	55	49.6	59.7	54.5	46.9	39.9	33.6	39.2	34.9
127	80%	Supply	54.9	60.7	67.4	66.6	61.8	56	39.6	37.7	49.5
		Extract	50.4	52	61.2	56.6	45.1	39.6	34.2	40.2	39.1
		Breakout	53.5	53.4	60.8	59.1	53	45.3	36	40.1	38.7
137	100%	Supply	54.7	61.7	70.5	69.9	62.7	57.5	42.1	38.3	52
		Extract	54.4	55.1	65.8	57.5	46.9	40.6	33.7	40	41.8
		Breakout	56.6	54.6	60.5	60.7	54.7	45.9	36.5	39.6	40

Tested according to BS848. Breakout quoted spherical. Supply and Extract quoted hemispherical.

Consultants Specification

Operation

The supply and extract ventilation unit shall be as Sentinel Kinetic Plus as manufactured by Vent-Axia and shall be sized as indicated on the drawings and shall be in accordance with the particular specification.

Supply air to the room shall be pre-heated by the extract air via the integrated composite plastic counterflow heat recovery cell. The Sentinel Kinetic Plus shall automatically vary the ventilation rate via EC/DC motors, as it receives signals from one of the optional interconnected sensors.

When a signal is received, the fans shall either vary their speed proportionally or on a trickle and boost principle.

The unit shall have the facility to commission the supply and extract fans individually via in-built minimum and maximum speed adjustment, or alternative wired remote control unit. The fans themselves shall have independent, infinitely variable speed control.

Unit Specification

The unit shall be manufactured with an ABS outer case construction, and incorporate a reversible core to allow for left or right hand mounting.

The unit shall have a high efficiency composite plastic counterflow heat exchanger, supply and extract filters, automatic summer bypass, integral minimum and maximum infinitely variable speed controls with facia mounted failure indication.

The unit shall have low energy, high efficiency EC/DC fan/motor assemblies with sealed for life bearings. The impellers shall be high efficiency backward curved centrifugal type.

The unit shall have a heat exchanger cell with a thermal efficiency of up to 92% when tested to EN 308. This shall be protected by G3 grade synthetic filters on supply and extract. Complete with a condensate drip tray and drain connection.

The unit shall be constructed with a removable Core allowing full maintenance access. The removable Core shall provide access to the following:

- ✓ Supply and extract filter
- ✓ Heat exchanger
- ✓ Access to the electrical connections

Access shall be provided for wiring termination and setup/commissioning. The backlit LCD user interface therein may be duplicated for remote mounting if required. Units shall be as manufactured by Vent-Axia Ltd.

Standard Controls

All Sentinel Kinetic units shall incorporate the following functions integrally mounted, pre-wired and factory fitted by the manufacturer:

- ✓ Integral infinitely variable fan speed control on supply and extract
- ✓ Integral min/max ventilation control/set point
- ✓ Integral BMS input/output interfaces – control and status indication
- ✓ Heating interlocks
- ✓ 0-10V proportional speed adjustment
- ✓ Volt free contacts
- ✓ 24V sensor supply
- ✓ Integral on/off or trickle boost function from remote switch, e.g. PIR occupancy detector

- ✓ Fully automatic summer bypass
- ✓ Switched Live input with adjustable 'delay-on' feature
- ✓ Fan failure or component failure indicated via individual fault code display
- ✓ Running time counter
- ✓ Control panel PIN number lock
- ✓ Automatic frost protection effective to -20°C
- ✓ The unit shall incorporate an integral humidity sensor with the following features:
 - Ambient Response; Raises the humidity trigger point as dwelling temperature reduces
 - Rapid Response: Monitors the rate of change in humidity and triggers increased airflow even if the humidity trigger threshold is not reached
 - Proportional Response; Incrementally increases the fan speed to reduce noise and reduce energy consumption
- ✓ The unit shall be controlled by the 'Sentinel' control devices (enablers and sensors) as detailed in the schedule or on the drawings.
- ✓ Tool free filter access

Mounting Option

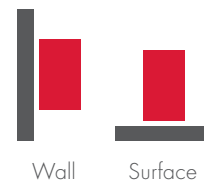

Airflow Direction

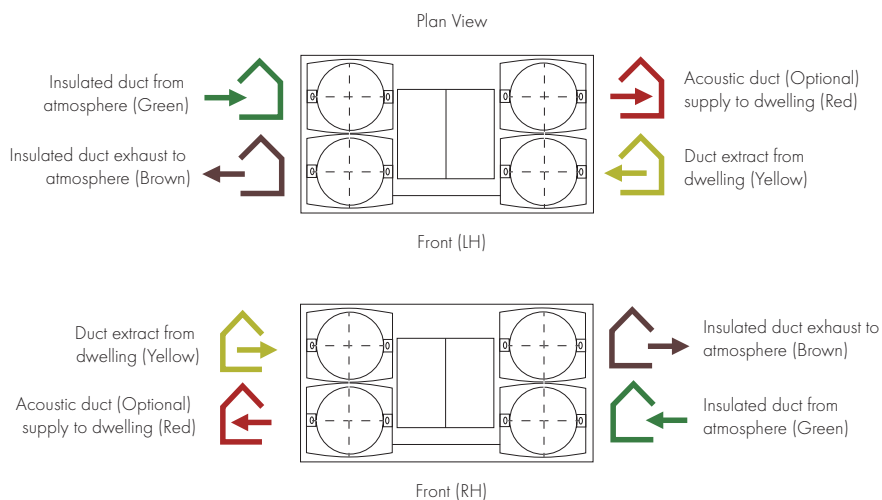

Electrical Connection

Please note: Electrical connection should be carried out by an appropriately qualified person and in accordance with current wiring regulations.

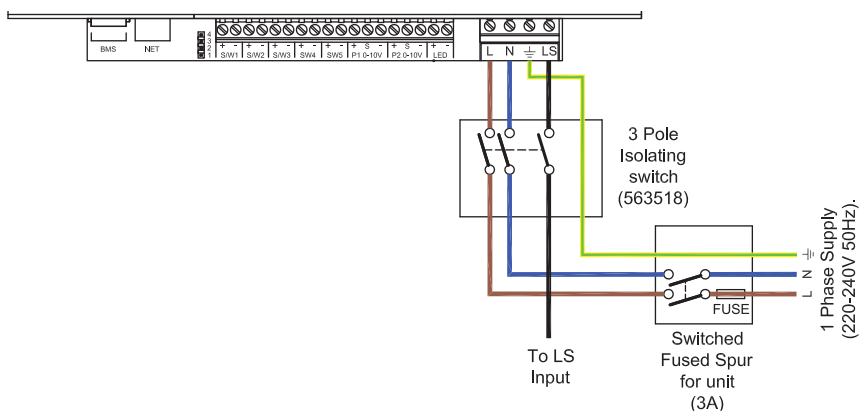

Trickle to Boost by two lighting circuits or Trickle/Boost switch

Lo-Carbon Sentinel Kinetic High Flow

Features & Benefits

- Recognised in SAP PCDB
- 180mm/200mm spigots
- Horizontal duct option for space-saving installations
- High airflow, ideal for student accommodation clusters
- Unique folding filter for removal when access is restricted
- Integrated digital controller for simple and accurate commissioning
- Plug and play controls; Humidistat, Ventwise, Wireless Remote
- BMS connectivity
- LS inputs (Light Switch)
- Volt-free inputs



Increased Performance

The Sentinel Kinetic High Flow benefits from the latest high efficiency, backward curved impeller design, ensuring the lowest possible energy consumption, and an exceptional performance range covering small one bed apartments to the largest of houses.

Care Homes & Student Accommodation

The Sentinel Kinetic High Flow is ideal for larger homes and multiple occupancy units such as care homes and student accommodation. Capable of 175l/s at 150Pa, the unit can extract from up to fourteen bathrooms and a communal kitchen while still achieving almost 90% heat recovery. The fully automatic capability of the Kinetic range means that adequate ventilation is always achieved.

The Kinetic's BMS capability is also ideal for those commercial applications where landlords or property managers want to monitor and optimise building performance and maintenance. The Kinetic BMS can provide status information and its self diagnostics can report if any fault is found.

Spigot Options

180mm/200mm Spigots may be re-positioned to give horizontal connection or a combination of vertical and horizontal connection.

Models

Model	Stock Ref
Kinetic High Flow Right	408449
Kinetic High Flow Left	408451

For further details, see Sentinel Kinetic Plus.

SAP PCDB Test Results

Exhaust Terminal Configuration	Thermal Efficiency %	SFP (W/l/s)
K + 1	88%	0.65
K + 2	88%	0.54
K + 3	90%	0.52
K + 4	90%	0.55
K + 5	91%	0.6
K + 6	91%	0.66
K + 7	90%	0.74

SEC Rating

Model	SEC Class
Kinetic High Flow	A

Dimensions (mm)

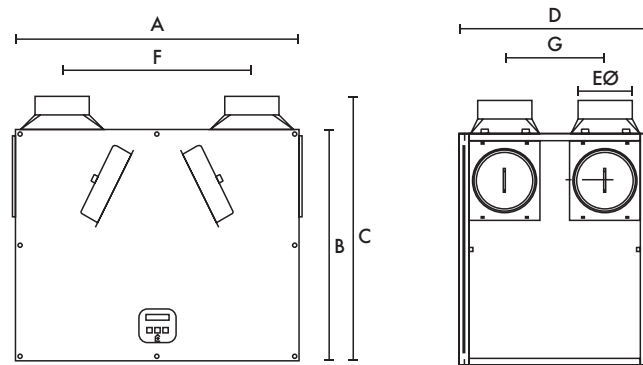

A	B	C	D	EØ	F	G
785	635	722	550	180/200	520	275

Weight: 34kg

Performance

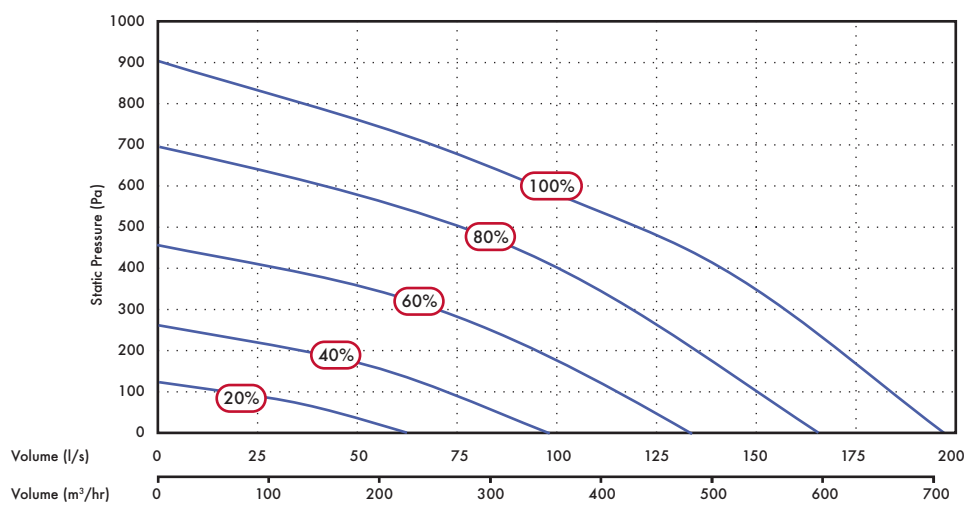

Sound Data

Test Mode	Flow %	Octave band, Hz, dB SWL								SPL dB(A) @ 3m
		63	125	250	500	1.0K	2.0K	4.0K	8.0K	
Supply	20	55.1	65.9	55.2	53.8	44.4	37.4	25.3	24.9	37.4
Extract		58.2	57.4	48	45.6	43.8	34.5	20	24.5	31.1
Breakout		43.3	46.6	44.9	44.7	41.8	30.4	21.6	22.5	25
Supply	40	63.1	69	67.1	64	55	51.6	39.7	32.4	46.8
Extract		58.6	58.4	60.1	53.7	41.9	41.5	31.7	25.1	37.5
Breakout		55.4	49.6	60.6	53.8	46.5	41.5	33.2	27.4	34
Supply	60	70.3	74.3	81.4	71.5	63.6	59.9	49.6	43.1	57.4
Extract		64.4	64.2	72.6	59.1	48.7	45.7	37.8	29.3	47.6
Breakout		62.8	54.6	65.7	57.2	55.5	49.2	41.4	36.4	40.5
Supply	80	75.3	77.9	88.1	78.7	68.4	65.1	56	50.1	64
Extract		71.1	68.2	73.6	61.8	51.9	49.5	42.7	37.6	49.1
Breakout		66.2	59	73.4	61.8	57	54.6	47.3	43.1	47.5
Supply	100	90.9	80.9	84.4	80.1	71.5	68	59.3	54.5	63.3
Extract		92.4	71.8	78.1	67.4	54.9	51.5	44.6	41.4	55.1
Breakout		69.3	62.9	74.9	67.5	59.2	56.6	49.1	44.7	49.5

Tested according to BS848. Breakout quoted spherical. Supply and Extract quoted hemispherical.

Lo-Carbon Sentinel Kinetic Cooker Hood

Features & Benefits

- Recognised in SAP PCDB
- Includes Cooker Hood Canopy
- Horizontal duct option for space-saving installations
- Fits within a 600mm wide aperture (300mm deep)
- Integrated digital controller for simple and accurate commissioning
- Plug and play controls; Humidistat, Ventwise, Wireless Remote
- BMS connectivity
- LS inputs (Light Switch)
- Volt-free inputs
- Self diagnosis for simplified fault finding
- Adjustable delay On/delay Off timer



Easy Installation

Ducting can be attached to the unit horizontally, vertically or both. Minimum internal depth of kitchen cupboard: 300mm.

Horizontal and Vertical Spigots: The combination of spigot options allows installation in confined locations. If vertical and horizontal connection are required on the same outlet/inlet, additional spigots can be supplied.

The condensate connection can be taken through the rear of the unit or through the side of the unit into an adjacent cupboard prior to connection into pre-installed domestic waste water system.

Cooker Hood Unit

The Sentinel Kinetic Cooker Hood is designed to fit in a 600mm wide aperture above a hob. The telescopic hood incorporates two flat removable metal grease filters, low energy light bulbs and is available with a White or Brushed Aluminium front trim.

The hood contains an integral fire damper in accordance with BRE Digest 398 and is connected to the heat recovery unit by a galvanised steel duct with access for cleaning. When the hood is opened, the heat recovery unit goes to boost speed and the summer bypass automatically opens to prevent cooking by-products entering the heat recovery cell. As an additional safety feature, the duct also contains a thermal cut-out fuse which turns off the MVHR unit in the event of excessive temperature in the airway. Cooker Hood units cannot be handed on-site and must be purchased as left hand (L) or right hand (R) models.

Models

Lo-Carbon Sentinel Kinetic with summer bypass and humidity sensor.

Model	Stock Ref
Kinetic CWH L (White Cooker Hood)	446756
Kinetic CSH L (Brushed Aluminium Cooker Hood)	446757
Kinetic CWH R (White Cooker Hood)	446758
Kinetic CSH R (Brushed Aluminium Cooker Hood)	446759

Integral Humidity Sensor

The integral humidity (models with H suffix) sensor increases speed in proportion to relative humidity levels, saving energy and reducing noise. The sensor also reacts to small but rapid increases in humidity, even if the normal trigger threshold is not reached. This unique feature ensures adequate ventilation, even for the smallest wet room. The night time relative humidity setback feature suppresses nuisance tripping as humidity gradually increases with falling temperature.

Accessories

Model	Stock Ref
Wired Remote Controller	443283
Wireless Enable Kit	441865
Wireless Transmitter Controller	437827
Ventwise Controller	441780
LED Alarm with 15m cable	448356
Opto-coupler for volt-free bms connection	447340
Kinetic Spare Filters 2 pk.	441774
M5 Pollen Filter	444200

SAP PCDB Test Results

	Thermal Efficiency %	SFP (W/l/s)
K+1	85	0.72
K+2	85	0.74
K+3	84	0.83
K+4	83	0.92

SEC Class Rating

Model	SEC Class
Kinetic CWH/CSH	A+

Dimensions (mm)

Minimum clearance from the bottom of this unit to the top of the hob must be:
Gas: 750mm
Electric: 650mm

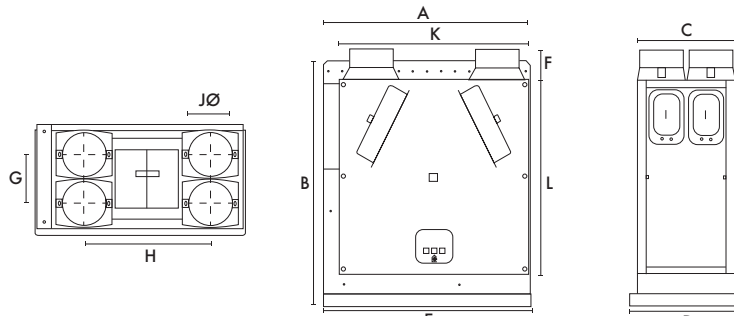

A	B	C	D	E	F	G	H	JØ	K	L	kg
590	710	295	316	598	90	140	360	125	550	550	27

Performance

Fan speeds are fully adjustable within the performance range.

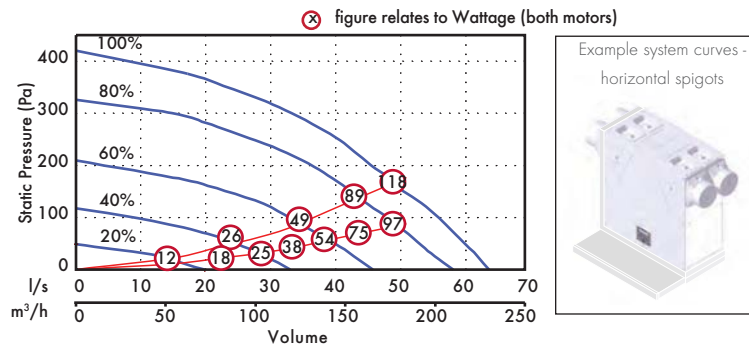
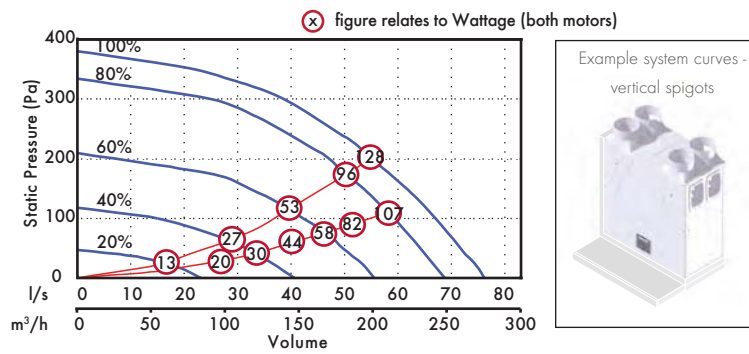

Sound Data

Flow l/s	Test mode	Octave band, Hz, dB SWL							SPL dB(A) @ 3m	
		63	125	250	500	1K	2k	4K		8K
10	Supply	47.8	40.2	38	31.1	28.2	22.1	23.6	30.9	21.4
	Extract	47	38.7	36	29.9	25	22.4	23.3	30.8	20.6
	Breakout	43.6	36.2	37.4	30.9	27.4	23.3	24.2	31.4	18.6
20	Supply	54	46.6	50.2	44.5	44.4	38.3	28.8	31.9	31.2
	Extract	46.8	40.5	34.6	34.2	34.6	25.9	23.7	30.3	22.9
	Breakout	45.9	39.9	40.6	35.7	33.5	28.4	25.3	31.2	21.3
30	Supply	58.1	54.5	57.6	52.2	51.7	47.6	38.6	35.8	38.5
	Extract	47.6	46.2	38.7	41.3	42.8	33.9	26.4	30.5	28.4
	Breakout	45.2	42.4	48.2	40.8	37.7	35.2	30	31.1	25.2
40	Supply	65.2	58.4	62.3	58	56.5	52.5	44.1	41.4	43.6
	Extract	53.5	53	44	47.7	48.1	39.7	31.5	31.5	33.5
	Breakout	50.9	47.6	47.4	48.1	42.5	40.8	36.3	34.4	29.3
50	Supply	66.4	63.2	66.3	62.5	61.7	57.4	50	47.8	48.3
	Extract	64.2	55.2	48	50.9	52.1	44.5	35.9	35	37.2
	Breakout	55	51	51.3	51.6	46.9	46.0	42	38.3	33.2

Tested according to BS848. Breakout quoted spherical. Supply and Extract quoted hemispherical.

Consultants Specification

Operation

The supply and extract ventilation unit shall be a Sentinel Kinetic as manufactured by Vent-Axia and shall be sized as indicated on the drawings and shall be in accordance with the particular specification.

Supply air to the room shall be pre-heated by the extract air via the integrated composite plastic counterflow heat recovery cell. The Sentinel Kinetic shall automatically vary the ventilation rate via EC/DC motors, as it receives signals from one of the optional interconnected sensors. When a signal is received, the fans shall either vary their speed proportionally or on a trickle and boost principle.

The unit shall have the facility to commission the supply and extract fans individually via in-built minimum and maximum speed adjustment, or alternative wired remote control unit. The fans themselves shall have independent, infinitely variable speed control.

Unit Specification

The unit shall be manufactured with an ABS outer case construction, and incorporate a metal duct to the cooker hood, intumescent fire damper and thermal switch, in accordance with BRE Digest 398.

The unit shall have a high efficiency composite plastic counterflow heat exchanger, supply and extract filters, automatic summer bypass, integral minimum and maximum infinitely variable speed controls with fascia mounted failure indication. The unit shall have low energy, high efficiency EC/DC fan/motor assemblies with sealed for life bearings. The impellers shall be high efficiency forward curved centrifugal type.

The unit shall have a heat exchanger cell with a thermal efficiency of up to 92% when tested to EN 308. This shall be protected by G3 grade synthetic filters on supply and extract. Complete with a condensate drip tray and drain connection.

The unit shall be constructed with a removable Core allowing full maintenance access. The removable Core shall provide access to the following:

- ✓ Supply and extract filter
- ✓ Heat exchanger
- ✓ Access to the electrical connections

Access shall be provided for wiring termination and setup/commissioning. The backlit LCD user interface therein shall be removable for remote mounting if required.

Units shall be as manufactured by Vent-Axia Ltd.

Standard Controls

All Sentinel Kinetic units shall incorporate the following functions integrally mounted, pre-wired and factory fitted by the manufacturer:

- ✓ Integral infinitely variable fan speed control on supply and extract
- ✓ Integral min/max ventilation control/set point
- ✓ Integral BMS interfaces - control and status indication
- ✓ Heating interlocks
- ✓ 0-10V proportional speed adjustment
- ✓ Volt free contacts
- ✓ 24V sensor supply
- ✓ Integral on/off or trickle boost function from remote switch e.g. PIR occupancy detector
- ✓ The unit shall be controlled by the 'Sentinel' control devices (enablers and sensors) as detailed in the schedule or on the drawings
- ✓ Fully automatic summer bypass
- ✓ Switched Live input with adjustable 'Delay-On' feature

- ✓ Fan failure or component failure indicated via individual fault code display
- ✓ Running time counter
- ✓ Control panel PIN number lock
- ✓ Automatic frost protection effective to -20°C
- ✓ Tool free filter access
- ✓ The unit shall incorporate ('H' models) an integral humidity sensor with the following features:
 - Ambient Response; Raises the humidity trigger point as dwelling temperature reduces
 - Rapid Response; Monitors the rate of change in humidity and triggers increased airflow even if the humidity trigger threshold is not reached
 - Proportional Response; Incrementally increases the fan speed to reduce noise and reduce energy consumption

Integral Cooker Hood Specification

The Sentinel Kinetic Cooker Hood shall consist of a telescopic Hood and galvanised steel duct connection to the MVHR Unit.

The Hood construction shall be of grey powder coated steel with Brushed Aluminium or White painted fascia.

The Hood shall trigger the MVHR unit to a pre-defined boost speed and open the summer bypass when opened, and shall have two low-energy lamps illuminating the hob top.

Filter shall be a flat metal grease filter, removable for cleaning.

The galvanised steel ductwork shall provide a continuous fire barrier between the Hood and the MVHR unit. It shall contain an Intumescent fire damper, thermal cut-out and volume balancing damper. The thermal cut-out shall switch off the MVHR unit at a pre-defined safety temperature.

The duct shall have an access panel for cleaning by the end-user.

Mounting Option



Wall

Airflow Direction

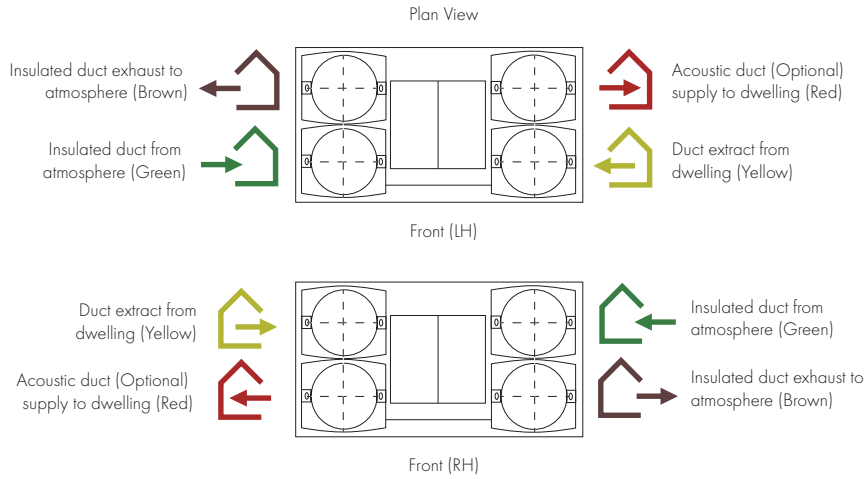

Electrical Connection

Please note: Electrical connection should be carried out by an appropriately qualified person and in accordance with current wiring regulations.

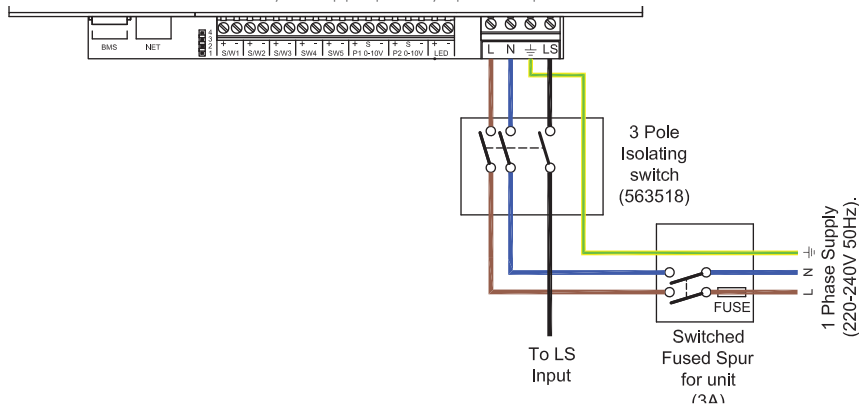

Trickle to Boost by a Light Circuit

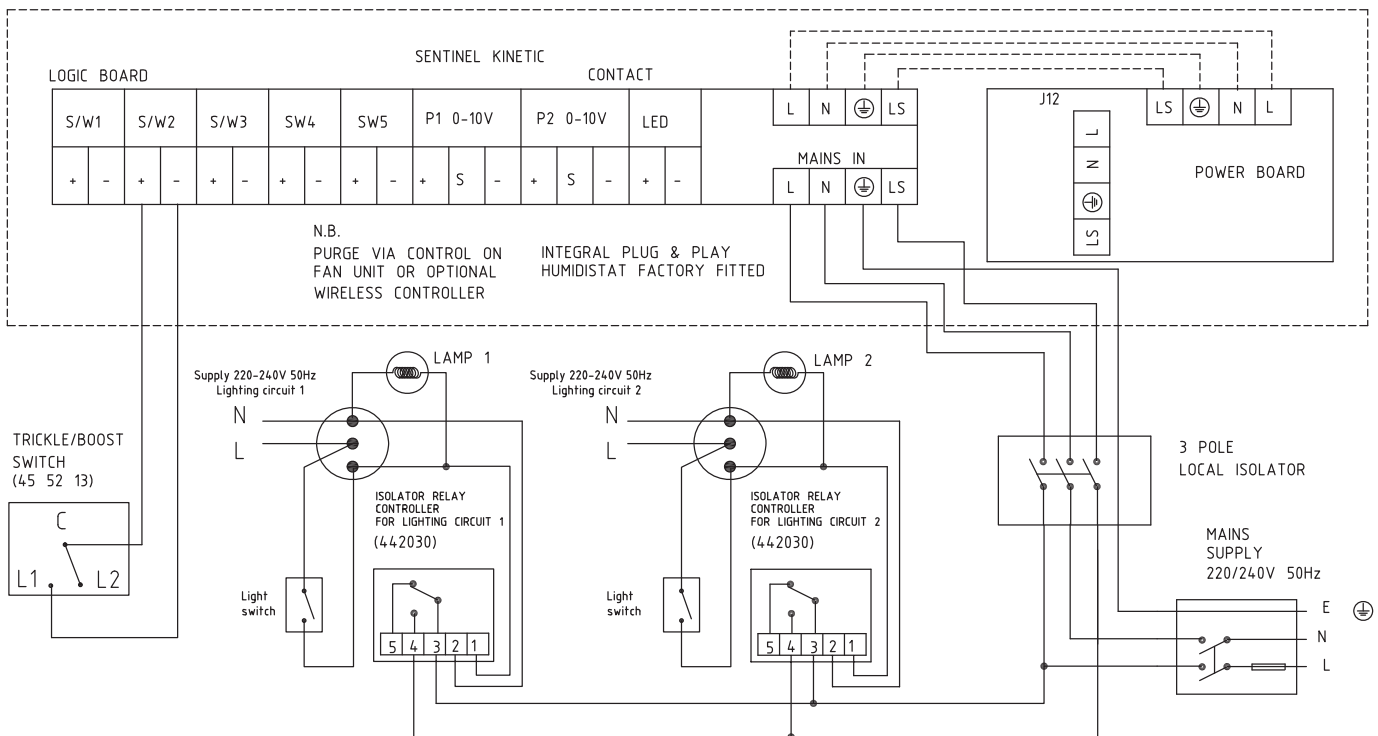

Lo-Carbon Sentinel Kinetic Horizontal

Features & Benefits

- Manufactured in the UK
- Building Regulations ADF compliant
- Recognised in SAP PCDB
- Energy Savings Trust best practice compliant
- Up to 81% heat recovery whilst controlling condensation
- Programmable Summer bypass
- Digital controller for simple and accurate commissioning
- External condensate connection
- Plug and play controls; Humidistat, Ventwise, Wireless remote
- LS inputs (Light Switch)
- Volt-free inputs



The Sentinel Kinetic Horizontal Range

A wholehouse heat recovery system with up to 81% heat exchange efficiency. An easily accessible heat recovery cube protected by two removable G3 filters. Two Lo-Carbon Energy Saving EC/DC fans ensure long life (typically over double the life of AC motors) and lowest possible energy use. Fully insulated construction with built-in condensation drain. Specifically designed for new build constructions with a high level of insulation.

Lo-Carbon Sentinel Kinetic Horizontal meets the latest requirements of the Building Regulations ADF for wholehouse system ventilation: System 4. Continuous mechanical supply and extract with heat recovery. Each model has three fully adjustable speeds and a purge setting (maximum flow). Supplied with the unit is a digital controller that can be used to pre-set the speeds to any required airflow within the performance range.

Integral Humidity Sensor

The integral humidity sensor ('H' models) increases speed in proportion to relative humidity levels, saving energy and reducing noise. The sensor also reacts to small but rapid increases in humidity, even if the normal trigger threshold is not reached. This unique feature ensures adequate ventilation, even for the smallest wet room. The night time relative humidity setback feature suppresses nuisance tripping as humidity gradually increases with falling temperature. Acoustically lined - low noise levels from only 20dB(A) @ 3m.

Models

Model	Stock Ref
Kinetic 200ZPH	407162
Kinetic 200ZH	449540
Kinetic 300ZH	449536
Kinetic 200ZMH	448778

Optional Controls

Model	Stock Ref
Wireless Enable Kit (includes one switch)	441865

Wireless Boost Switch (max 3 switches)	437827
Ventwise Controller (also requires sensors: see Accessories & Controllers section)	441780

Accessories

Model	Stock Ref
Spare Filters Kinetic 200Z/ZH (2 pack)	449524
Spare Filters Kinetic 300ZH (2 pack)	449575
Spare Filters Kinetic 200ZMH (2 pack)	449524

Multiple Control Options:

Five Volt-free pairs of switch terminals for sensor inputs allow boosting from a full range of Vent-Axia controllers - humidistats, PIR, timers.

Two terminals with 0-24V outputs allow 0V to 10V proportional control by sophisticated controllers such as CO₂ sensors and proportional humidistats.

The optional Ventwise controller senses temperature rise in a bath/shower hot water supply and/or current in a cooker/hob electrical circuit to activate boost, ensuring additional ventilation when needed. Switch-live for boosting via light switches (220-240V AC) or manual Normal/Boost switches. This connection has the advantage of Delay-On and Delay-Off facility. Delay-On enables you to prevent the Boost airflow between 0 and 10 minutes after a light switch has been activated. Delay-Off allows the Boost airflow to continue after a light switch is turned off to ensure effective clearance of humidity. This timer is adjustable between 0 and 25 minutes.

Summer Bypass

An internal damper operates when the external temperature is below the internal temperature, and the internal temperature is too high.

The bypass opens and allows the cooler outside air to help cool the dwelling.

Normal mode: Fans run on Normal speed with bypass open until the internal dwelling temperature falls below the set 'Indoor' (maximum desired) temperature.

Evening Purge mode: The fans run on Boost speed until the internal temperature falls below the set 'Indoor' temperature. If, after five hours the internal temperature is still above the set 'Indoor' temperature, the unit will switch down to normal speed for the remainder of the 'bypass open' period.

NightTime Purge mode: As Evening Purge, except that the unit will continue on Boost speed until the internal air temperature reaches the 'Outdoor' temperature set point (Default 14°C). This mode gives pre-cooling of the dwelling for the following day.

In Evening and Night Time Purge modes, the user can turn off the boost function by pressing the Boost button.

Frost Protection

In cold climates there is a possibility of frost building up on the intake side of the heat exchanger. In order to prevent damage, the Kinetic reduces supply flow while maintaining extract flow at temperatures down to -20°C.

SEC Class Rating

Model	SEC Class
Kinetic 200ZH/ZPH/ZMH	A
Kinetic 300ZH	A

SAP PCDB Test Results

200ZPH		
	Thermal Efficiency %	SFP (W/l/s)
K+1	86	0.62
K+2	84	0.65
K+3	83	0.76

200ZH/ZMH		
	Thermal Efficiency %	SFP (W/l/s)
K+1	80	0.69
K+2	81	0.70
K+3	80	0.80
K+4	80	0.97
K+5	79	1.14

300ZH		
	Thermal Efficiency %	SFP (W/l/s)
K+1	77	0.59
K+2	78	0.51
K+3	78	0.57
K+4	78	0.66
K+5	78	0.76
K+6	78	0.88
K+7	77	1.05

Dimensions (mm)

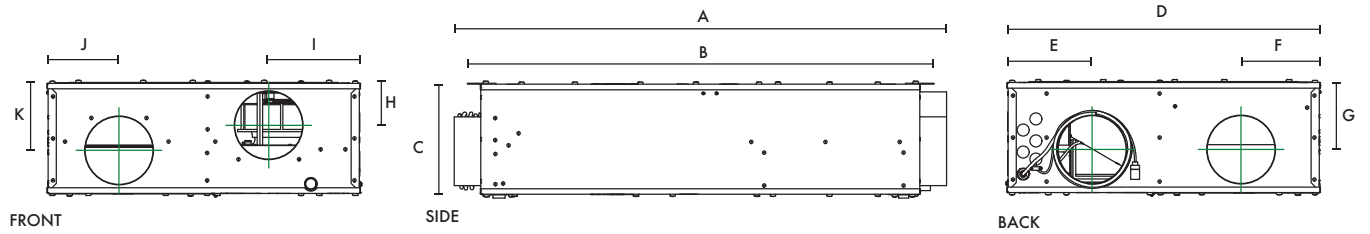

Model	A	B	C	D	E	F	G	H	I	J	K	Spigots Ø
200ZH	895	849	200	570	155	144	122	76	167	131	122	125
300ZH	985	940	301	720	184	179	187	102	279	174	187	150

Weight: 200ZH - 26kg, 300ZH - 38kg

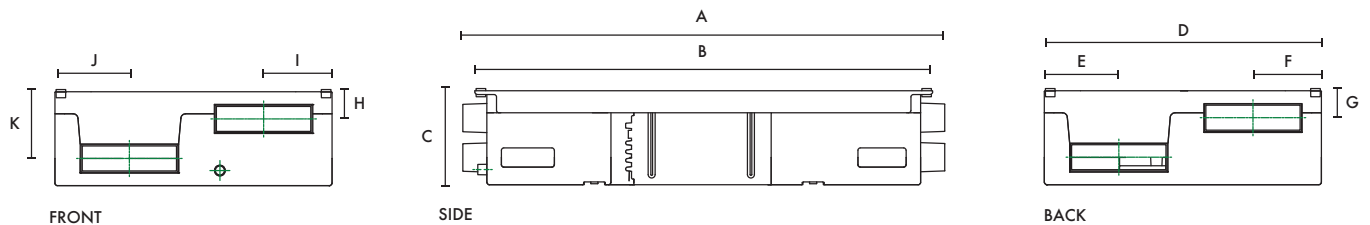

Model	A	B	C	D	E	F	G	H	I	J	K	Spigots
200ZPH	1000	950	200	575	155	142	60	61	142	154	143	204x60
200ZMH*	895	849	200	570	195	140	54	66	168	138	143	204x60

Weight: 200ZPH - 14kg, 200ZMH - 26kg

*Galvanized steel outer case construction

Performance - 200ZH/ZMH/ZPH Model

Fan speeds are fully adjustable within the performance range.

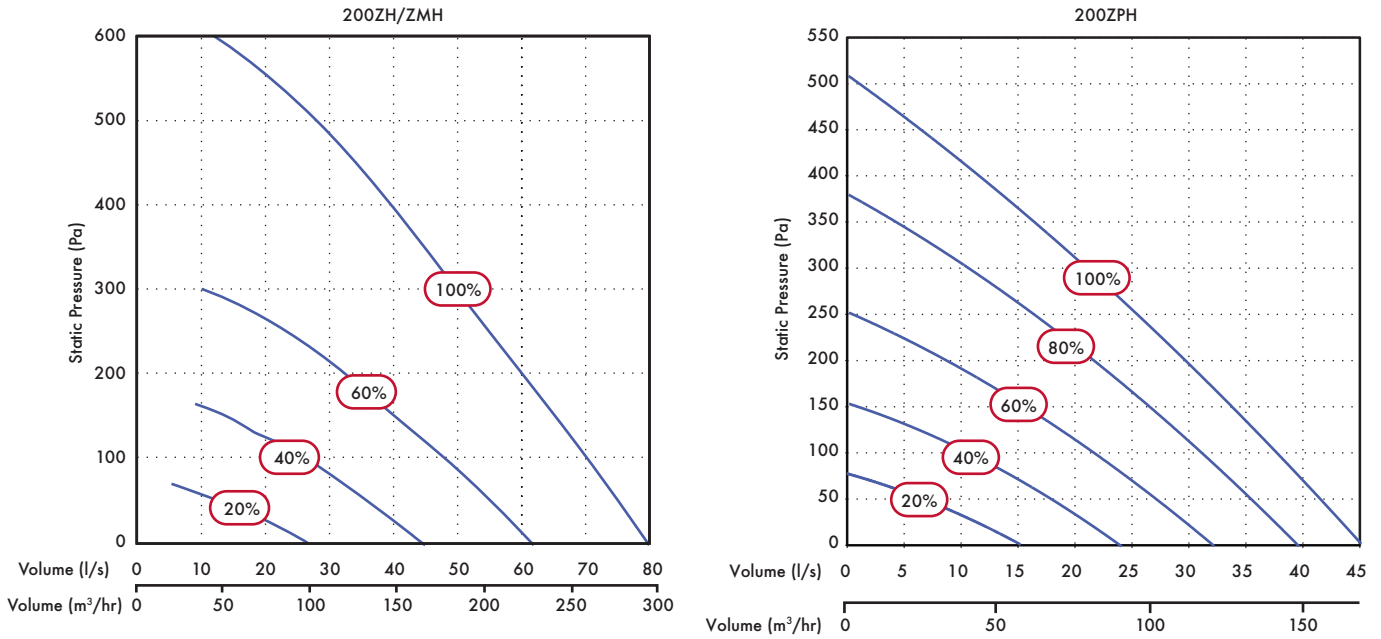

Sound Data - 200ZH/ZMH Model

Flow %	Test mode	63	125	250	500	1k	2k	4k	8k	dB(A) at 3m
20	Supply	50.3	54	50.1	45.5	37	36	27.5	31.1	30.0
	Extract	47.2	47.7	46.6	41.8	30.7	27.9	24.6	30.5	26.3
	Breakout	48.8	55.8	51.2	43.8	32.4	29.0	25.4	30.8	26.8
40	Supply	52.7	61.7	60.1	61.8	47.4	45.1	38.1	40.1	42.7
	Extract	50.7	55.4	55.0	51.5	37.5	34.6	25.9	30.7	33.9
	Breakout	53.7	60.1	61.1	50.7	40.2	35.8	27.1	30.3	34.0
60	Supply	52.8	64.5	66.7	59.4	51.1	51.1	42.9	39.3	44.0
	Extract	50.6	59.0	62.1	57.1	43.7	40.0	29.0	31.6	39.7
	Breakout	55.1	64.4	66.8	57.5	47.0	41.4	32.0	32.0	39.7
100	Supply	58.3	69.2	68.6	64.6	56.9	56.1	47.9	45.6	48.1
	Extract	51.8	63.1	64.9	63.9	52.4	45.9	34.8	34.8	45.2
	Breakout	59.4	68.1	69.7	68.3	53.1	47.1	36.5	34.3	46.5

Sound Data - 200ZPH Model

Speed	Test mode	63	125	250	500	1k	2k	4k	8k	dB(A) at 3m
20%	Breakout	48.3	41.3	37.7	35.8	34.5	28.2	26	31.2	21.5
	Supply	39.6	37.1	36	32.9	30.6	22.9	24.9	29.4	23.1
	Extract	49.4	40.7	35	30.4	26.3	22.5	23.6	30.1	20.8
40%	Breakout	47.8	42.2	46.7	40.6	40.2	34.2	28.1	31.2	25.3
	Supply	45.7	38.3	40.7	39	38.1	28.7	24.9	28.5	28.1
	Extract	50	45.5	39.9	37	34.3	28.6	25.1	30.6	24.3
60%	Breakout	54.4	51.2	53.8	46.2	43	38.9	33.8	32	29.7
	Supply	46.1	49.2	45.3	44.4	42.4	35.2	27	29.3	32.7
	Extract	49.5	41.9	45.4	41.7	39.4	35.2	27.6	30.3	27.7
80%	Breakout	50.4	51.2	56.7	53.9	48.5	43.2	39.9	34.9	34.5
	Supply	52.9	48.9	47.5	51.3	47.2	40.8	31.2	30	36.8
	Extract	48.9	43.3	46.8	50	42.4	38.6	31.3	30.1	32.2
100%	Breakout	49.3	49.8	52.9	54	51	46.3	41.2	35.7	35.1
	Supply	43.8	45.8	50.7	56.3	50	44.3	35.7	29.7	38.2
Extract	53.2	46.9	48	52.8	45.4	42.1	35.1	30.5	34.9	

Performance - 300ZH Model

Fan speeds are fully adjustable within the performance range.

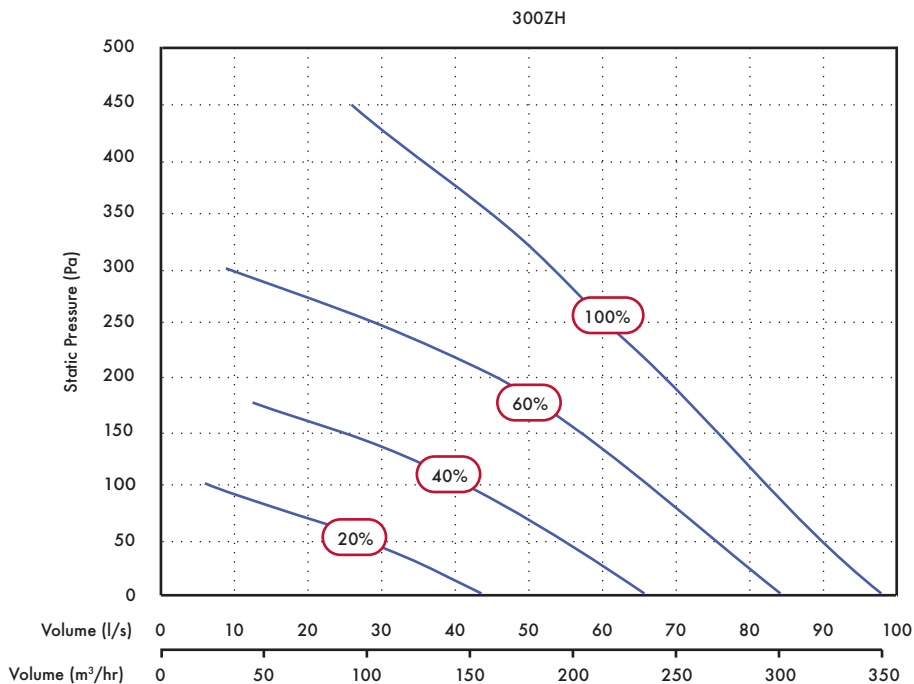

Sound Data - 300ZH Model

Flow l/s	Flow %	Test mode	63	125	250	500	1k	2k	4k	8k	dB(A) at 3m
26	10	Supply	42.5	42.8	38.3	32.9	28	24.6	25.5	30.3	26.3
		Extract	46.9	45	40.3	34.4	27.4	23	24.3	30.1	22.5
		Breakout	48.7	52.1	47.7	40.5	32.9	27.3	25.1	31.6	24.4
44	20	Supply	45.6	47	41.7	35.7	31.7	26.7	24.8	30	29.9
		Extract	46.9	48.6	47	38.2	29.5	25.3	23.8	29.9	25.3
		Breakout	50.2	56.4	53.9	46.3	37.5	32.5	25.2	31.4	28.8
55	30	Supply	44.4	46	52.9	39.4	35.1	31.9	25.5	30.5	33.9
		Extract	47	48	55.5	42.5	32.2	29.9	25.7	30.6	30.6
		Breakout	52.2	59.6	62	51.4	41.9	37.4	28.1	31.4	34.7
66	40	Supply	43.1	44.4	54.3	43.5	39.2	35.7	27.7	29.9	35.0
		Extract	48.9	49	58.4	45.9	35.7	33.4	25.3	29.9	33.4
		Breakout	54.6	58.3	66.1	52.6	39.3	36.5	31.1	35.3	37.7
85	60	Supply	44.7	49.8	58	50.4	45	41.9	30.6	30.3	39.1
		Extract	51	53.6	61.2	50.1	41.6	40.1	30.7	31.1	36.7
		Breakout	57.5	62.6	68.7	57.5	45.9	41	36.3	34	40.7
96	80	Supply	46	52.2	57.1	56.5	47.2	44.2	32.3	30.5	40.5
		Extract	55.5	55	63.1	53.4	44.3	41	33.5	31.4	38.8
		Breakout	62.2	65.7	68.8	63	50.8	43.8	38.8	35.4	42.9
98	100	Supply	46.6	52.3	57	55.4	47.1	43.7	32.1	30.3	40.1
		Extract	53.7	55.2	63.3	53.3	44.1	41.2	33.2	31.5	38.9
		Breakout	62.2	73.8	77.4	74.1	67.4	61	53.6	45.4	53.9

Tested according to BS848. Breakout quoted spherical. Supply and Extract quoted hemispherical.

Consultants Specification

Operation

The supply and extract ventilation unit shall be as Sentinel Kinetic Z as manufactured by Vent-Axia and shall be sized as indicated on the drawings and shall be in accordance with the particular specification; 200Z - 200mm deep, 300Z - 300mm deep.

The Sentinel Kinetic Z shall automatically vary the ventilation rate via EC/DC motors, as it receives signals from one of the optional interconnected sensors. When a signal is received, the fans shall either vary their speed proportionally or on a trickle and boost principle.

The unit shall have the facility to commission the supply and extract fans individually via the wired remote control unit. The fans themselves shall have independent, infinitely variable speed control.

Unit Specification (200Z/ZM, 300ZH)

The unit shall be manufactured with a galvanized steel outer case construction and shall have a high efficiency aluminium heat exchanger.

Unit Specification (200ZP)

The unit shall be manufactured with high density EPP case and shall have a high efficiency polymer heat exchanger.

The unit shall have supply and extract filters, automatic summer bypass, integral minimum and maximum infinitely variable speed controls with failure indication via the wired remote controller.

The unit shall have low energy, high efficiency EC/DC fan/motor assemblies with sealed for life bearings. The impellers shall be high efficiency backward curved centrifugal type.

The unit shall have a heat exchanger cell with a thermal efficiency of up to 81% when tested to EN 308. This shall be protected by G3 grade synthetic filters on supply and extract. Complete with a condensate drip tray and drain connection.

The unit shall be constructed with a removable access panel allowing full maintenance access from below. The removable panel shall provide access to the following:

- ✓ Supply or extract fan
- ✓ Supply and extract filter
- ✓ Heat exchanger
- ✓ Access to the electrical connections

Access shall be provided for wiring termination and setup/commissioning.

Standard Controls

All Sentinel Kinetic Z units shall incorporate the following functions integrally mounted, pre-wired and factory fitted by the manufacturer:

- ✓ Infinitely variable fan speed control on supply and extract
- ✓ Min/max ventilation control/set point
- ✓ Heating interlocks
- ✓ 0-10V proportional speed adjustment
- ✓ Volt free contacts
- ✓ 24V sensor supply
- ✓ On/off or trickle boost function from remote switch, e.g. PIR occupancy detector
- ✓ The unit shall be controlled by the 'Sentinel' control devices (enablers and sensors) as detailed in the schedule or on the drawings
- ✓ Fully automatic summer bypass
- ✓ Switched Live input with adjustable 'delay-on' feature

- ✓ Fan failure or component failure indicated via individual fault code display
- ✓ Running time counter
- ✓ Control panel PIN number lock
- ✓ Automatic frost protection effective to -20°C
- ✓ The unit shall incorporate ('H' models) an integral humidity sensor with the following features:
 - Ambient Response: Raises the humidity trigger point as dwelling temperature reduces
 - Rapid Response: Monitors the rate of change in humidity and triggers increased airflow even if the humidity trigger threshold is not reached
 - Proportional Response: Incrementally increases the fan speed to reduce noise and reduce energy consumption

The unit shall be controlled by the 'Sentinel' control devices (enablers and sensors) as detailed in the schedule or on the drawings.

Mounting Option



Slab

Airflow Direction

View from beneath (drawing for airflow demonstration only - not intended to be an accurate representation of the product)

View from beneath

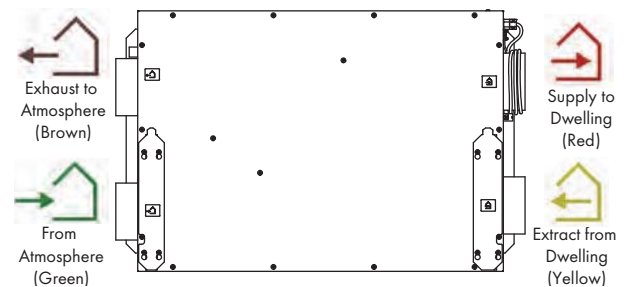

Electrical Connection

Please note: Electrical connection should be carried out by an appropriately qualified person and in accordance with current wiring regulations.

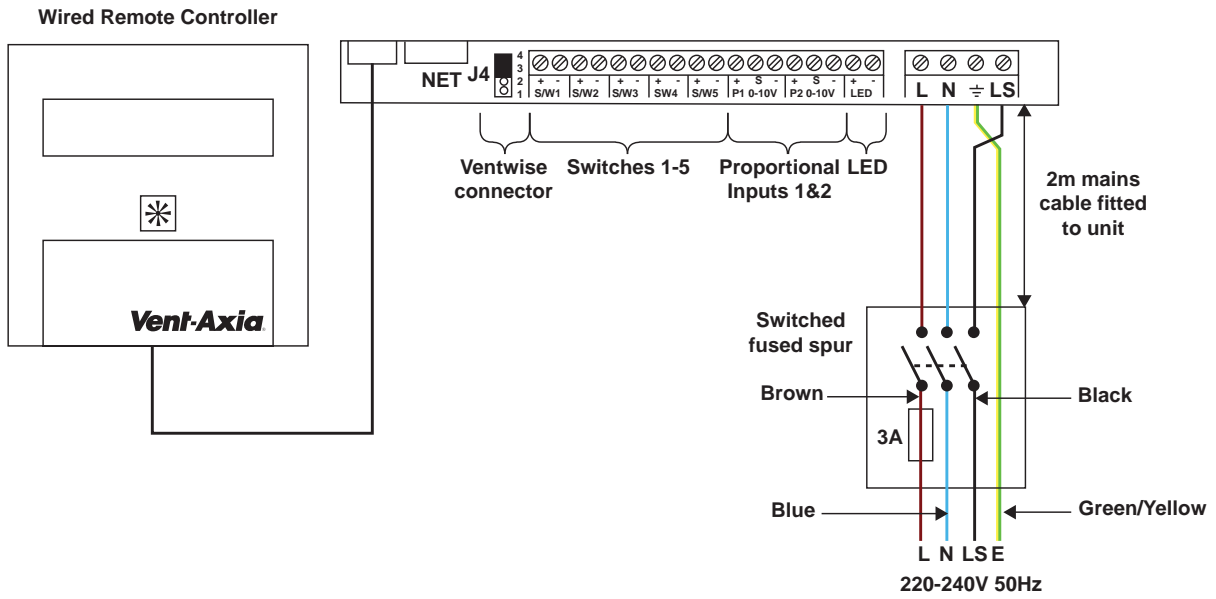

Trickle to Boost by two lighting circuits or Trickle/Boost switch

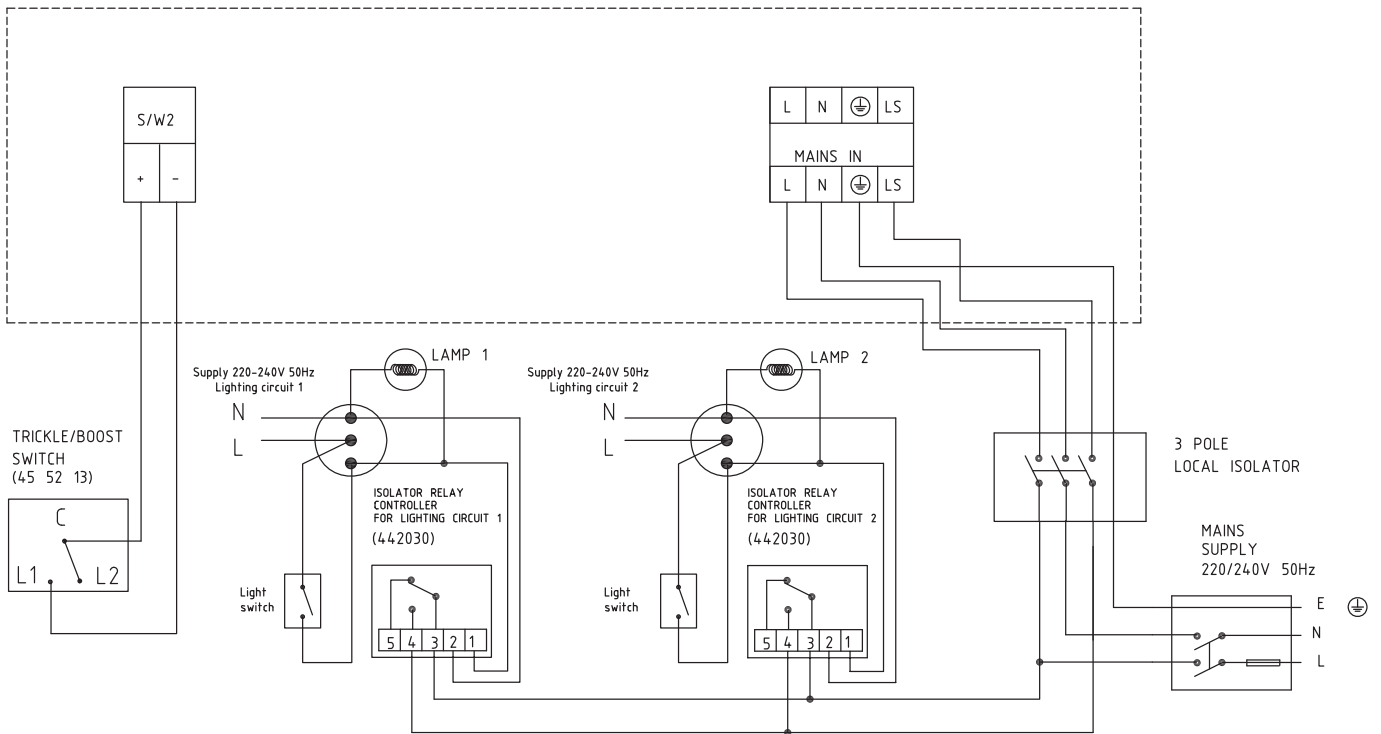

Lo-Carbon Kinetic Plus E

Features & Benefits

- Lightweight for easy installation
- Easy access filters
- External condensate connection
- Compatible with a range of controls: PIR, Humidistat
- Horizontal duct option for space-saving installations
- Up to 94% heat recovery
- Summer mode
- Manufactured in the UK
- Switched live inputs (Light switch control)



A wholehouse heat recovery system with up to 94% energy efficiency. An easily accessible heat recovery cube protected by two removable GU3 filters. Two Lo-Carbon Energy Saving EC/DC fans ensure long life (typically over double the life of AC motors) and lowest possible energy use. Fully insulated construction with built-in condensation drain.

Lo-Carbon Kinetic Plus E meets the latest requirements of the Building Regulations Approved Document F for wholehouse system ventilation.

The Lo-Carbon Kinetic Plus E model has two adjustable speeds, normal and boost. On the front of the unit is the controller that can be used to preset the speeds to any required performance, up to 111l/s (400m³/hr) 150Pa. Offering 'Close Control' to prevent over ventilating. Acoustically lined - low noise levels from only 20dB(A) @ 3m.

Left or Right Hand Installation

Units are supplied right handed with duct spigots to outside on the right hand side. These can be reversed onsite by simply removing the control panel, rotating the unit 180 degrees and reattaching the control panel.

Spigot Options

The combination of spigot options allows installation in confined locations. If vertical and horizontal connections are required on the same outlet/inlet, additional spigots can be supplied.

Filter Check

An LED on the control panel illuminates at 6 month intervals to remind users to check and clean the filters.

Frost Protection

The Kinetic E range benefits from an automatic frost protection system to prevent the heat recovery cell freezing in very cold weather, while at the same time maintaining ventilation.

Control Options

There are two LS (Switched Live) inputs allowing the unit to be connected to a number of sensors and controllers such as Ventwise, Timespan, Ambient Response Humidistat. One of the LS connections also benefits from a 'Delay-On' feature which prevents the unit boosting unnecessarily.

Model

Model	Stock Ref
Kinetic Plus E	449059

Accessories

Model	Stock Ref
Kinetic Plus E Spare Filters 2 pack	403702
Optional M5 Pollen Filter	444201
Isolator Relay Controller	442030
180mm/200mm Spigot Kit (One per pack)	446523

SAP PCDB Test Results

Exhaust Terminal Configuration	Thermal Efficiency %	SFP (W/l/s)
K + 1	94	0.41
K + 2	94	0.40
K + 3	94	0.43
K + 4	94	0.45
K + 5	93	0.52
K + 6	93	0.61
K + 7	93	0.73

SEC Rating

Model	SEC Class
Kinetic Plus E	A+

Dimensions (mm)

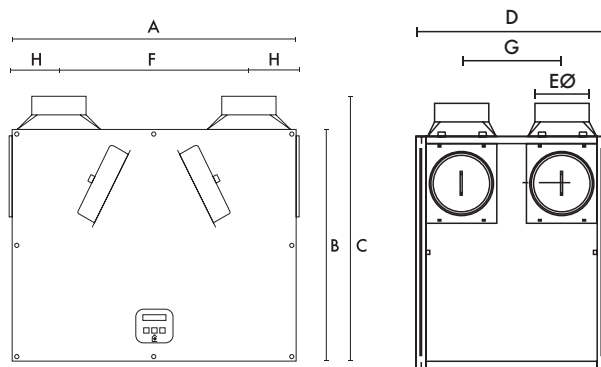

A	B	C	D	EØ	F	G	H
785	635	722	550	150	520	275	135

Weight: 24kg

Performance

Fan speeds are fully adjustable within the performance range.

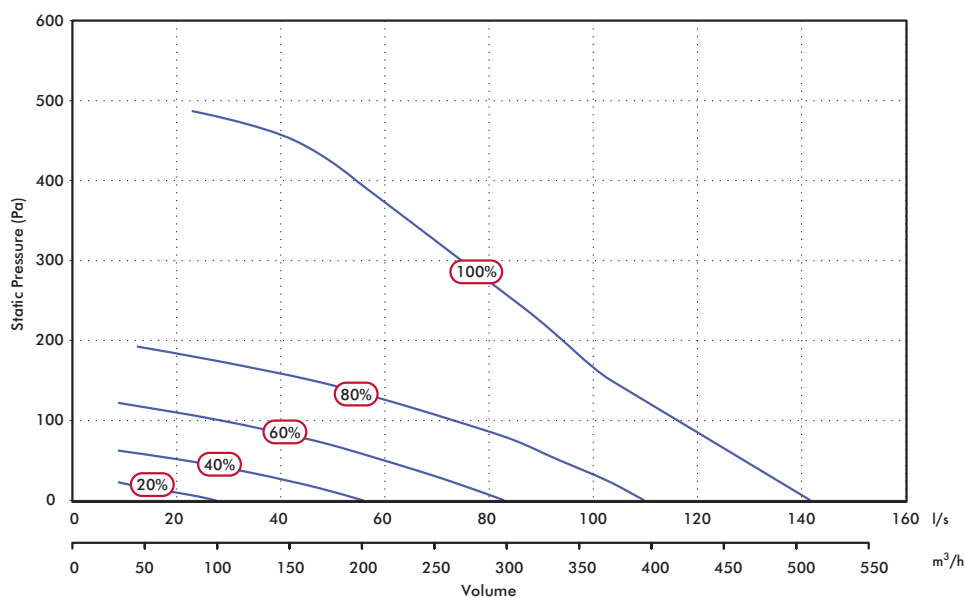

Sound Data

Flow l/s	Unit setting	Test mode	Octave band, Hz, dB SWL								SPL dB(A) at 3m
			63	125	250	500	1k	2k	4k	8k	
50	20%	Supply	46.5	54.3	46.4	44.8	36.2	28.5	24.5	31.2	28.5
		Extract	46	52.2	42.3	38.7	27.6	24.2	24	31.7	25
		Breakout	48.5	42.6	43.3	38.9	35.8	29.3	23.8	30.7	22.8
78	40%	Supply	50.3	59.1	54.5	56.5	47	39.9	26.3	31.7	38
		Extract	46.8	51.6	47.8	44.4	32.7	27.4	24.4	31.7	28
		Breakout	48.4	51.2	53.4	46	41	34.6	25	30.3	28.5
104	60%	Supply	52.4	57.2	60.4	60.9	55.8	50.3	33.1	33.9	43.6
		Extract	50	49.8	56.8	52.4	40.2	35.9	33.4	39.8	35.2
		Breakout	55	49.6	59.7	54.5	46.9	39.9	33.6	39.2	34.9
127	80%	Supply	54.9	60.7	67.4	66.6	61.8	56	39.6	37.7	49.5
		Extract	50.4	52	61.2	56.6	45.1	39.6	34.2	40.2	39.1
		Breakout	53.5	53.4	60.8	59.1	53	45.3	36	40.1	38.7
137	100%	Supply	54.7	61.7	70.5	69.9	62.7	57.5	42.1	38.3	52
		Extract	54.4	55.1	65.8	57.5	46.9	40.6	33.7	40	41.8
		Breakout	56.6	54.6	60.5	60.7	54.7	45.9	36.5	39.6	40

Tested according to BS848. Breakout quoted spherical. Supply and Extract quoted hemispherical.

Consultants Specification

Operation

The supply and extract ventilation unit shall be as Kinetic Plus E as manufactured by Vent-Axia and shall be sized as indicated on the drawings and shall be in accordance with the particular specification.

Supply air to the room shall be pre-heated by the extract air via the integrated composite plastic counterflow heat recovery cell. The Kinetic Plus E shall automatically vary the ventilation rate via EC/DC motors, as it receives signals from one of the optional interconnected sensors. When a signal is received, the fans shall vary their speed on a trickle and boost principle. The unit shall have the facility to commission the supply and extract fans individually via in-built minimum and maximum speed adjustment. The fans themselves shall have independent, infinitely variable speed control.

Unit Specification

The unit shall be manufactured with an ABS outer case construction, and incorporate a reversible core to allow for left or right hand mounting. The unit shall have a high efficiency composite plastic counterflow heat exchanger, supply and extract filters, integral minimum and maximum infinitely variable speed controls with facia mounted failure indication.

The unit shall have low energy, high efficiency EC/DC fan/motor assemblies with sealed for life bearings. The impellers shall be high efficiency backward curved centrifugal type. The unit shall have a heat exchanger cell with a thermal efficiency of up to 94% when tested to EN 308. This shall be protected by G3 grade synthetic filters on supply and extract. Complete with a condensate drip tray and drain connection.

The unit shall be constructed with a removable Core allowing full maintenance access. The removable Core shall provide access to the following:

- ✓ Supply and extract filter
- ✓ Heat exchanger
- ✓ Access to the electrical connections

Access shall be provided for wiring termination and setup/commissioning.

Standard Controls

All Kinetic Plus E units shall incorporate the following functions integrally mounted, pre-wired and factory fitted by the manufacturer:

- ✓ Integral infinitely variable fan speed control on supply and extract
- ✓ Integral min/max ventilation control/set point
- ✓ Integral on/off or trickle boost function from remote switch, e.g. PIR occupancy detector
- ✓ Switched Live input with adjustable 'delay-on' feature
- ✓ Tool free filter access
- ✓ Frost protection down to -20°C
- ✓ LED 'filter check' indicator

Mounting Option

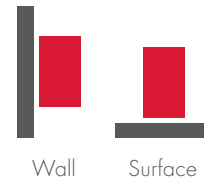

Airflow Direction

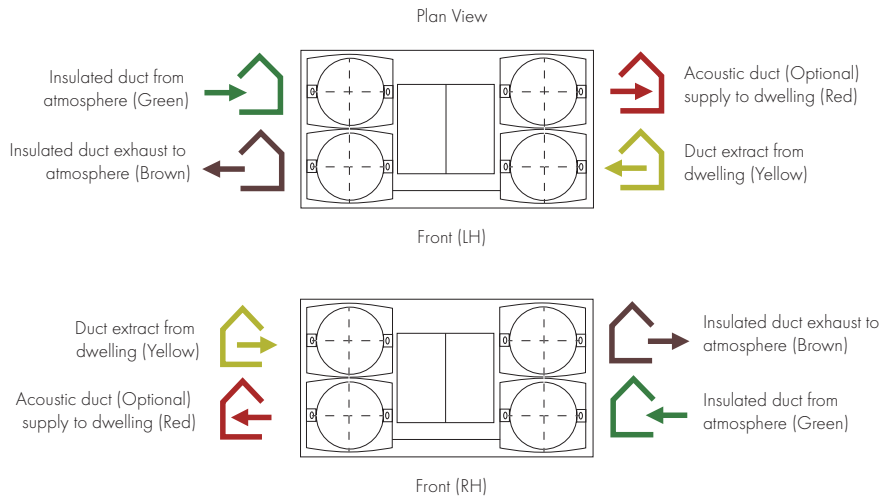

Electrical Connection

The unit can be switched to boost by applying 230 V to the LS1 or LS2 inputs. Alternatively, the boost button on the control unit may be used.

Mains Cable Connections

Terminal No.	Name	Description
L	Mains Live	220-240 V AC, 50 Hz input
N	Mains Neutral	220-240 V AC, 50 Hz input
EARTH	Mains Earth	Earthing connector
LS1	Switched Live 1	220-240 V AC, 50 Hz input
LS2	Switched Live 2	220-240 V AC, 50 Hz input

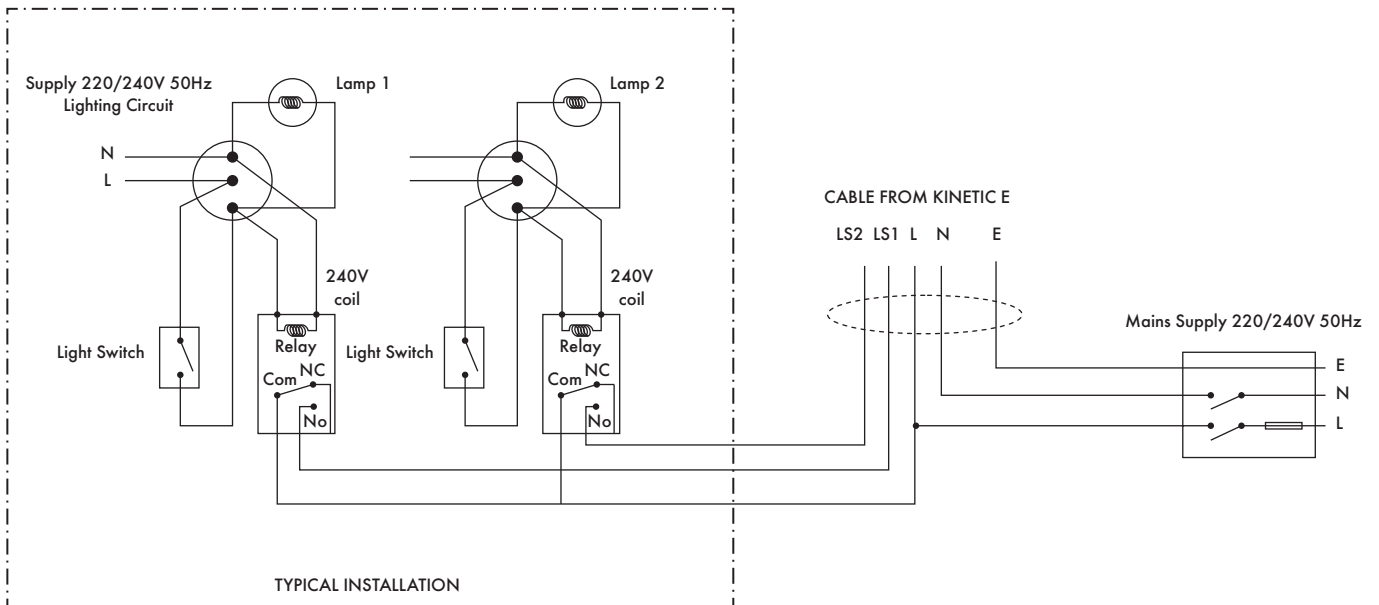

Integra

Features & Benefits

- Powered heat recovery unit for smaller residential or commercial applications up to 180m²
- Up to 70% heat recovery
- Low power consumption
- Effective condensation control
- Summer mode



The Integra heat recovery unit has been specially designed to provide ventilation for flats or rooms in residential, commercial, educational or leisure applications. Balanced ventilation is achieved by using nominal 100mm diameter rigid ducting.

Using a high performance, polymeric heat exchange cube, together with two powerful fans, the Vent-Axia Integra achieves efficiencies of up to 70%.

The compact cube interleaves outgoing moist air with incoming fresh air, allowing the heat from one to warm the other without the two air streams mixing. Energy is saved on room heating, with no power being used by the cube itself.

Performance of Integra: Up to 49l/s FID. Ideal for installation in ceilings voids or cupboards.

The 150VA Transformer enables the selection of trickle settings to match dwelling volume.

Models

Model	Stock Ref
Integra	456864

Controller

Model	Stock Ref
Controller 150VA	563538

Airflow Direction

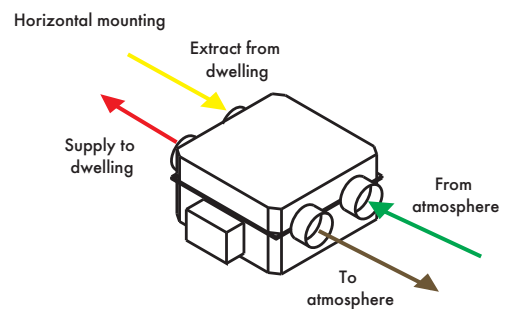

SEC Class Rating

Model	SEC Class	SEC Class (inc. LDC)
Integra	F	C

Dimensions (mm)

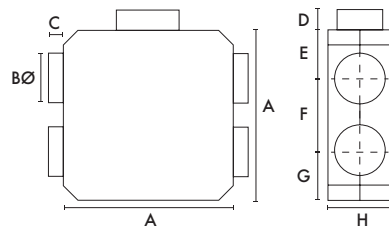

A	BØ	C	D	E	F	G	H
400	98	50	65	85	230	85	210

Weight: 6.5kg

Performance

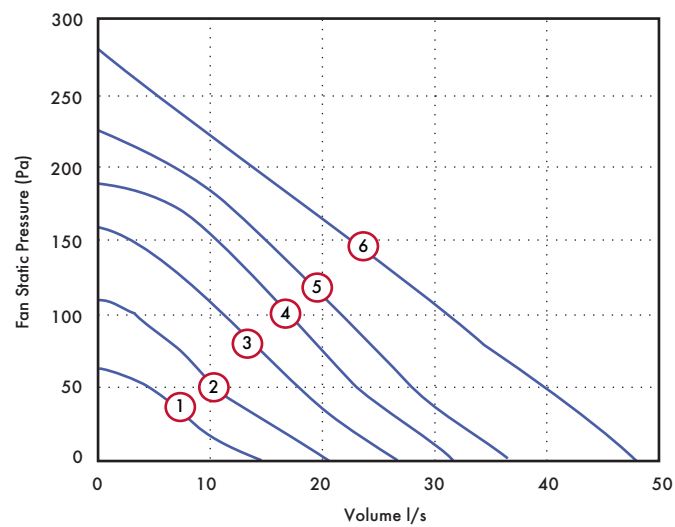

Motor Speed/Curve	Volume (l/s) (FID)	Voltage (V)	Wattage (W)
1	15	80	32
2	21	100	47
3	27	120	64
4	32	140	81
5	37	160	99
6	49	240	182

Integra to be used with a 150VA Transformer for maximum controllability.

NEW Integra Plus EC

Features & Benefits

- Powered heat recovery unit for larger residential or commercial applications
- Up to 70% heat recovery
- Low power consumption
- Effective condensation control
- 3 speed control
- Summer mode



Easy Installation

The Vent-Axia Integra Plus EC is designed for mounting in ceiling voids, lofts and above a suspended ceiling. Four 150mm spigots are provided for simple connection to insulated flexible or rigid ventilation ducting. The unit comes complete with a 22mm condensate outlet.

Controllers & Sensors

Model	Stock Ref
Ambient Response Humidistat	563550
Visionex PIR	459623
TIM2	370346

Model

Model	Stock Ref
Integra Plus EC	437666EC

SEC Rating

Model	SEC Class	SEC Class (inc. LDC)
Integra Plus	E	B

Airflow Direction

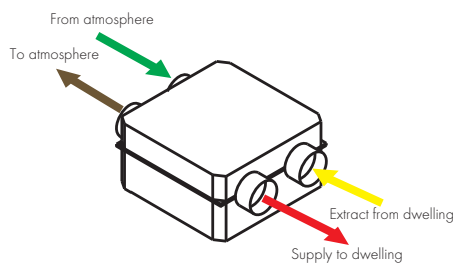

Dimensions (mm)

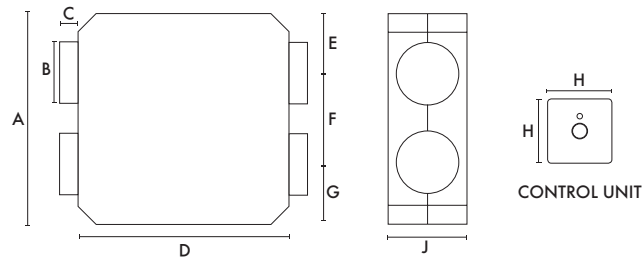

A	B	C	D	E	F	G	H	J
603	150	100	580	125	350	125	85	305

Weight: 15.5kg fan box

Performance

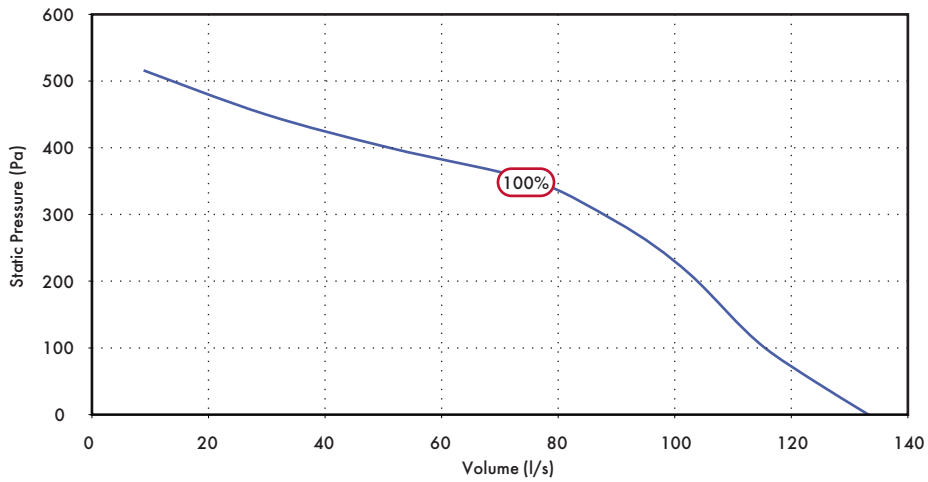

Sound Data

Flow, l/s	Unit setting V	Test mode	Octave band, Hz, dB SWL								SPL dB(A) at 3m
			63	125	250	500	1k	2k	4k	8k	
55	4	Supply	39.2	43.1	44.5	47.1	42.6	36.0	29.3	30.7	30.7
		Extract	47.0	42.4	38.6	40.4	35.5	28.0	27.9	32.6	25.3
		Breakout	43.2	42.7	38.2	37.6	33.4	28.4	27.6	31.5	21.7
69	5	Supply	42.0	47.6	46.1	49.9	48.8	41.2	33.7	32.5	34.4
		Extract	47.8	42.2	41.4	43.2	40.4	29.6	27.7	32.5	27.7
		Breakout	45.2	45.7	41.9	40.7	37.3	30.5	27.5	32.4	23.8
79	6	Supply	46.0	49.7	50.6	54.0	54.4	45.9	39.6	36.9	38.7
		Extract	44.5	43.2	44.8	46.4	46.2	32.2	28.4	32.3	31.4
		Breakout	46.2	47.2	44.3	43.4	43.1	32.8	28.5	32.2	26.6
81	6.6	Supply	47.0	52.5	53.8	56.4	58.3	48.8	42.8	40.8	41.8
		Extract	50.3	45.3	47.7	48.5	47.4	35.0	30.7	32.9	33.0
		Breakout	45.5	47.9	45.5	45.5	45.5	34.0	29.2	31.5	28.3
95	7	Supply	48.9	54.1	56.3	58.0	59.2	51.0	45.9	43.8	43.3
		Extract	47.6	46.5	49.4	49.7	48.3	37.0	31.1	32.3	34.0
		Breakout	49.0	49.5	48.2	47.5	47.3	36.7	31.1	32.3	30.1
109	8	Supply	51.0	58.2	57.4	60.1	61.2	54.4	48.9	48.0	45.6
		Extract	56.2	52.4	51.7	53.1	49.6	39.5	33.8	33.2	36.3
		Breakout	51.8	53.9	51.3	50.7	48.7	40.3	34.0	32.5	32.2
113	9	Supply	49.1	56.1	59.4	62.8	63.3	57.2	52.1	50.8	47.4
		Extract	54.5	50.9	52.4	54.5	51.4	42.3	35.3	33.8	37.8
		Breakout	53.6	54.3	52.8	52.3	50.8	43.4	36.2	33.5	34.1

Tested according to BS848. Breakout quoted spherical. Supply and Extract quoted hemispherical.

HR100R/RS

Features & Benefits

- Controls condensation and odours - saves energy
- Eliminates mould growth
- Up to 70% heat recovery
- Extremely quiet operation
- Two speed settings



The HR100R and HR100RS are ideal for single bedrooms/bathroom applications situated in hotel rooms, nursing homes and residential care homes.

The HR100R features top access making it ideal for loft installations.

The HR100RS features bottom access for installation on the slab above a suspended ceiling.

The HR100R/RS is a self-contained heat recovery unit for mounting in lofts and suspended ceilings. The unit is supplied without controls to allow for the unit to be tailored to suit the individual requirements.

Compatible with standard 100mm ducting for connection to internal grilles and external cowl.

The unit comes fitted with a single 2-speed motor, and provides continuous low volume ventilation with a boost option. A variety of control devices are available for manual or automatic speed control.

An integral heat exchanger transfers heat from the outgoing stale air to the fresh air supply, raising the supply air temperature whilst at the same time reducing its relative humidity.

Up to 18l/s FID capacity. The unit provides superior control of condensation and odours, ideal for bathrooms or small internal rooms.

Models

HR100R

Top access - ideal in loft installations.

Model	Stock Ref
HR100R	370377

HR100RS

Bottom access - ideal for suspended ceilings.

Model	Stock Ref
HR100R	435004

Controllers

Normal Boost Switch

A single gang switch to boost from high to low speeds on all heat recovery systems.

85 x 85 x 10mm (H x W x D)

Model	Stock Ref
Normal Boost Switch	455213

HR100RS Version

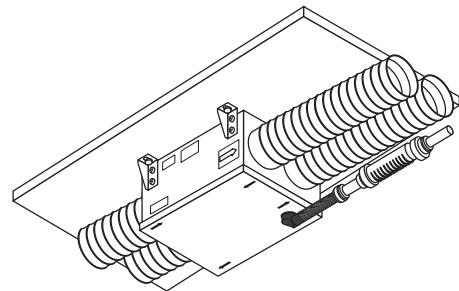

Dimensions (mm)

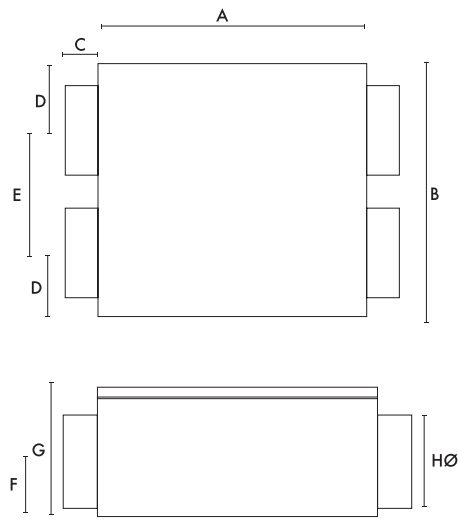

A	B	C	D	E	F	G	HØ
305	240	50	60	120	70	160	98

Performance

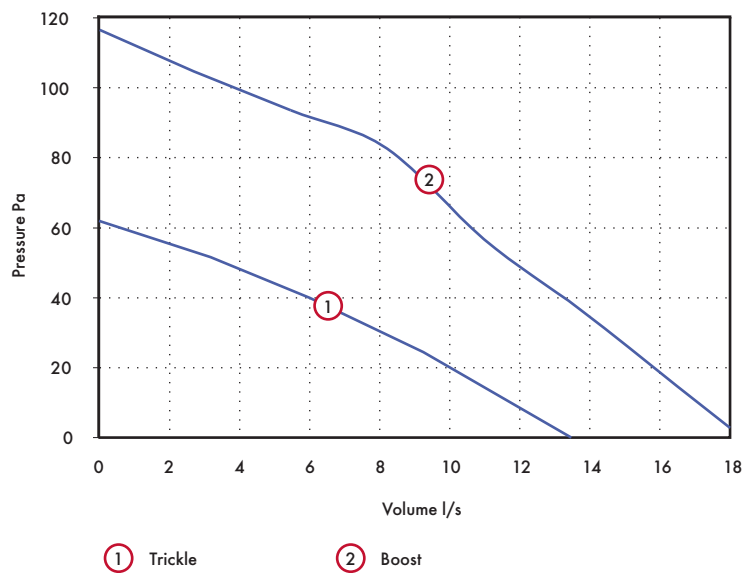

Model	Weight kg	Extract Perf. l/s		Watts		dB(A) @ 3m*	
		Boost	Trickle	Boost	Trickle	Boost	Trickle
HR100R	5.6	18.3	13.6	29	19	30	20
HR100RS	5.6	18.3	13.6	29	19	30	20

Mains electrical supply: 230V/50Hz

HR200V

Features & Benefits

- Powered heat recovery module for smaller commercial applications
- Up to 70% heat recovery
- 150mm duct connection
- Extremely quiet on low speeds
- Low power consumption
- Washable heat exchanger
- Pre-wired to a flexible cable



A ducted heat recovery unit for residential or commercial applications. The HR200V is self-contained and includes two mixed flow speed controllable fans. Using a high performance, polymeric heat exchange cube together with two power fans, the HR200V can boast a temperature efficiency of up to 70%. Low speed for trickle ventilation mode.

Specially designed to provide ventilation for small internal rooms in commercial, educational and leisure applications. Ventilation is achieved by using nominal 150mm diameter ducting.

Models

Model	Stock Ref
HR200V	14120010

Accessory

Model	Stock Ref
Transformer 150VA	563538

SEC Class Rating

Model	SEC Class	SEC Class (inc. LDC)
HR200V	C	B

Dimensions (mm)

Weight: 15.5kg fan box, 5kg controller

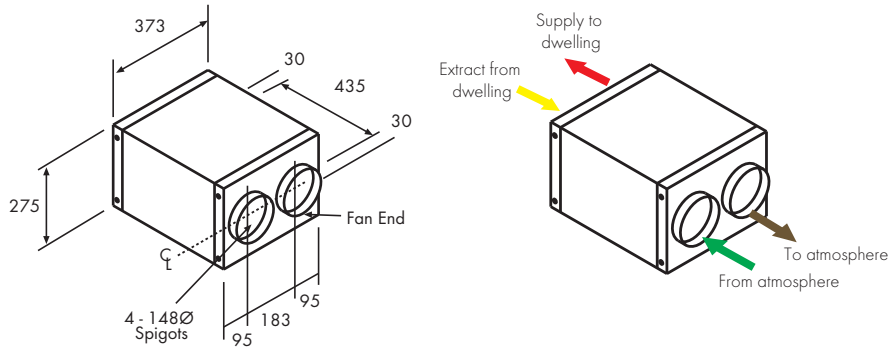

Performance

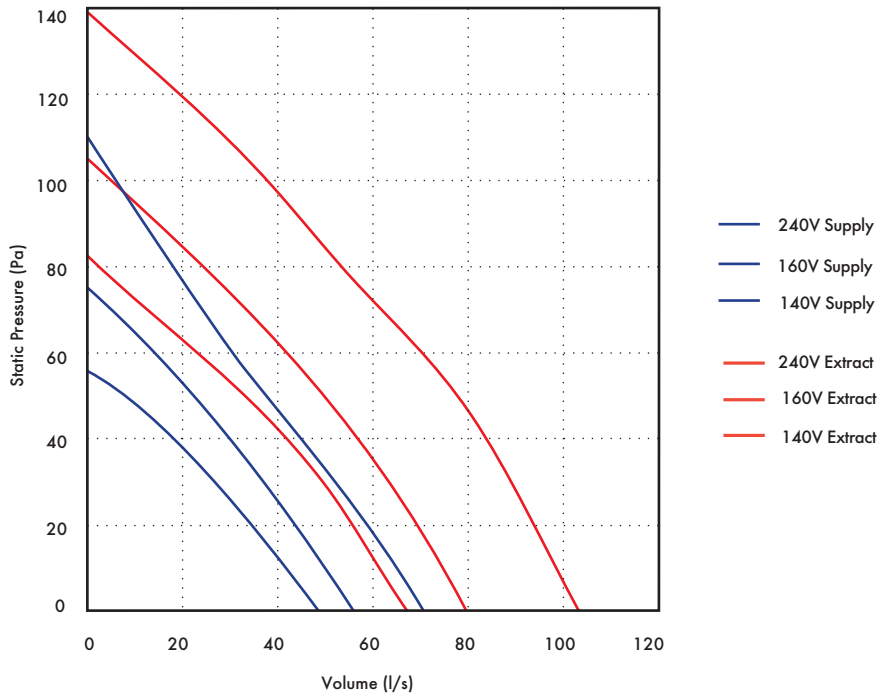

Motor Speed	1	2	3
Voltage	140	160	240
Watts	51.5	60	110
Volume l/s (FID) Supply	48.3	55.8	70.3
Extract	241	286	371

HR200V to be used with a 150VA Transformer for maximum controllability.

HR500

Features & Benefits

- Efficient 550m³/h heat recovery ventilation unit or high performance 900m³/h extract fan
- Lightweight, compact and easy to install
- Integral shutters on X type model
- Easy to clean
- Up to 70% heat recovery
- Controller with sensor mode, allows a range of sensors to be used in conjunction with the HR500 and HR500X units
- IPX5 rated



Heat Recovery Ventilation

HR500 heat recovery ventilation units for through the wall installation, which exhaust stale air whilst introducing warmed fresh air from the outside.

Ideal for computer rooms, classrooms, offices and the health and leisure industries. The Vent-Axia HR500 unit is the perfect solution for commercial areas that require a high performance balanced intake/extract ventilation scheme. As a heat recovery ventilation unit it moves a useful 153l/s of air.

The compact heat recovery cube interleaves outgoing warm air with incoming fresh air and allows the heat from one to warm the other without the two air streams mixing. Energy is saved on room heating with no power being used by the cube itself.

The HR500 and HR500X consist of a tough telescopic wall sleeve into which the main body of the unit is housed. Walls of up to 670mm thick can be easily accommodated. Behind the neat deflecting fascia grilles are the filters, the heat exchange cube and fan units. All wall sleeve components, the heat exchange cube and the fascia grilles are made of tough polymeric materials.

Electrical

Maximum ambient temperature +40°C.
Supply Voltage 220-240V/1/50Hz.

Models

HR500 Commercial

Wall-mounted intake/extract ventilation unit with built-in heat recovery facility. For commercial and leisure areas. Lightweight, compact and easy to install.

Model	Stock Ref
HR500	14101010

HR500X

As HR500 with shutters.

Model	Stock Ref
HR500X	14101070

Controller

HR500 Controller

Surface mounting. On/Off remote sensor mode. Heat exchange, single fan extract or twin fan extract modes. Infinitely variable speed. Minimum speed setting. Suitable for controlling up to 2x HR500. 86 x 156 x 53 (W x H x D).

Model	Stock Ref
HR500 Controller	W14301010

Dimensions (mm)

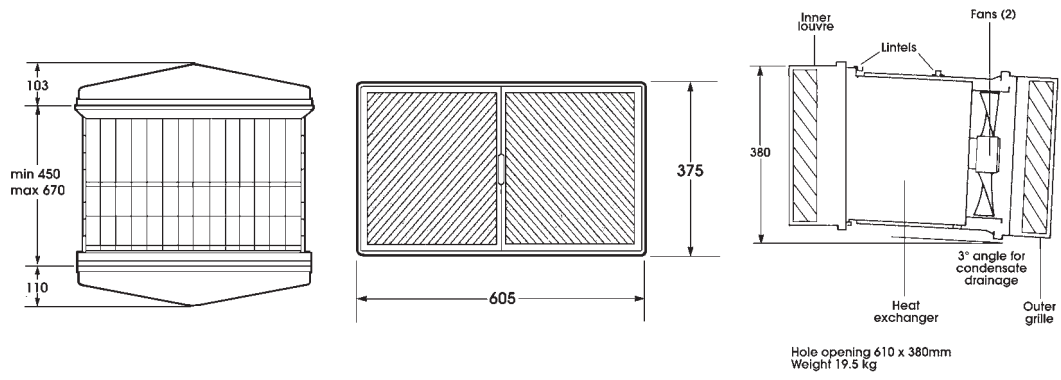

Performance

Model	Airflow performance (l/s)		Watts (max)	Sound dB(A) @ 3m (max)
	Heat recovery mode	Extract mode (max)		
HR500	153l/s	250l/s	200	53
HR500X	153l/s	250l/s	220	53

HR500D

Features & Benefits

- Self-contained unit with integral fans
- Up to 70% heat recovery
- Compatible with 200, 250 and 315mm Ø ducting and accessories
- External wall mounting



The HR500D is a self-contained unit with integral extract and supply fans to provide balanced ventilation and heat recovery via supply diffusers and extraction grilles. The unit is fully speed controllable.

The compact heat recovery cube interleaves outgoing warm air with incoming fresh air and allows the heat from one to warm the other without the two air streams mixing.

Energy is saved on room heating with no power being used by the cube itself.

Performance of HR500D: Supply and extract up to 174l/s FID capacity on heat recovery mode. Ideal for offices, computer rooms, pubs and clubs, etc.

Model

Surface mounting. On/Off remote sensor mode. Heat exchange, single fan extract or twin fan extract modes. Infinitely variable speed. Minimum speed setting. Suitable for controlling up to 2x HR500.

Model	Stock Ref
HR500D	370450

Controller

Model	Stock Ref
Speed Controller	W14301010

Spigot Sets

Model	Stock Ref
200mm Spigot set	434806
200mm Spigot set	434805
250mm Spigot set	434806
250mm Spigot set	434805
315mm Spigot set	434806

Dimensions (mm)

Hole opening: 610 x 381mm

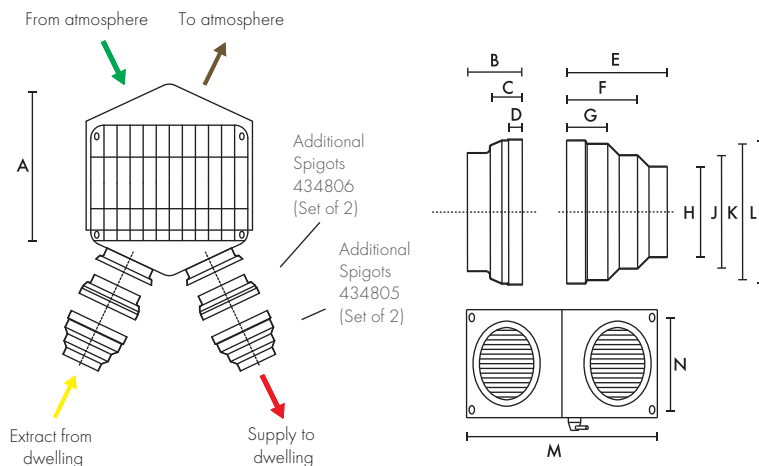

A	B	C	D	E	F	G	H	J	K	L	M	N
480-750	120	70	30	220	155	90	∅200	∅250	∅300	∅315	600	340

Performance Guide

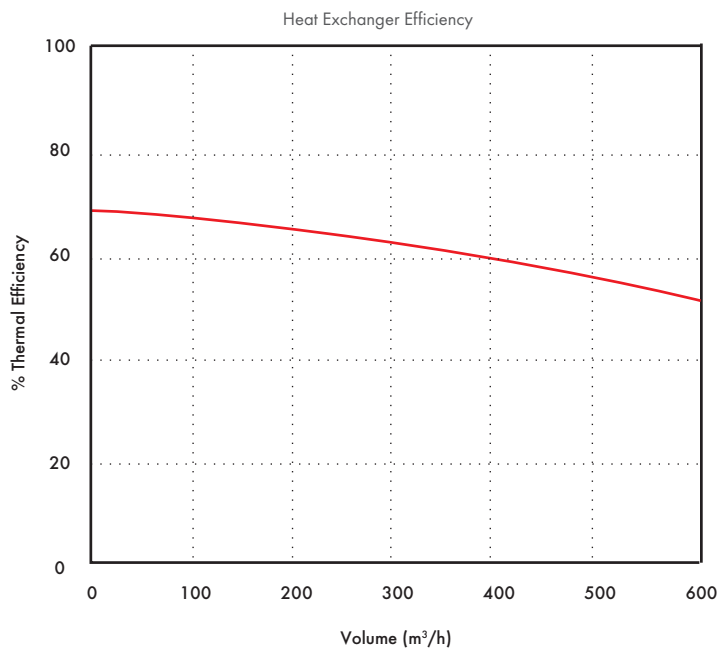

Airflow performance l/s (max)	Watts (max)	dB(A) @ 3m (max)	Weight kg
174 l/s	210	53	19

HR500EP/IP

Features & Benefits

- Passive - no fans
- Lightweight - easy installation
- Compatible with 200, 250 and 315mm Ø ducting and accessories
- Up to 70% heat recovery
- Internal wall mounting HR500IP
- External wall mounting HR500EP



The unit is a semi-remote heat exchange unit with 70% heat recovery, designed for mounting in internal walls (HR500IP) and external walls (HR500EP) for installations using ducted extraction and fresh air supply. The HR500 units provides air movement via two independent in-line duct fans to suit length and configuration of ducting systems. The unit is ideal for use with in-line centrifugal type fans and compatible accessories. Performance of HR500EP and HR500IP: Up to 244 l/s FID capacity (balanced airflow). Ideal for computer rooms, classrooms, offices and the health & leisure industries.

Model

Model	Stock Ref
HR500IP	370447
HR500EP	370451

Spigot Sets

200mm Spigot set	434806
200mm Spigot set	434805
250mm Spigot set	434806
250mm Spigot set	434805
315mm Spigot set	434806

EP Unit

Hole opening: 610 x 381 mm

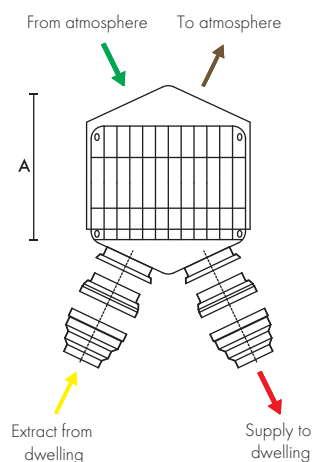

IP Unit

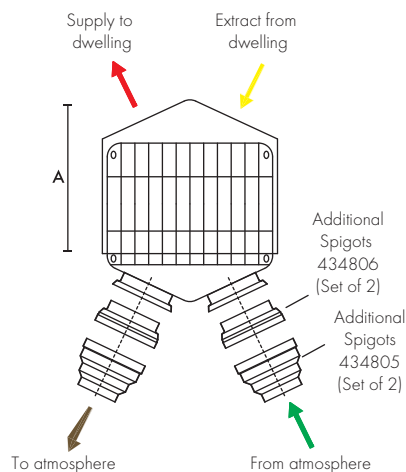

Dimensions (mm)

EP & IP Unit

Hole opening: 610 x 381mm

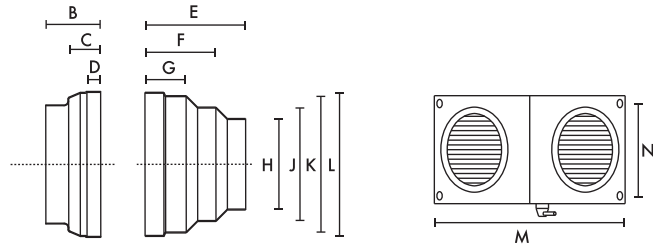

A	B	C	D	E	F	G	H	J	K	L	M	N
480-750	120	70	30	220	155	90	Ø200	Ø250	Ø300	Ø315	600	340

Weight: 9kg

Performance

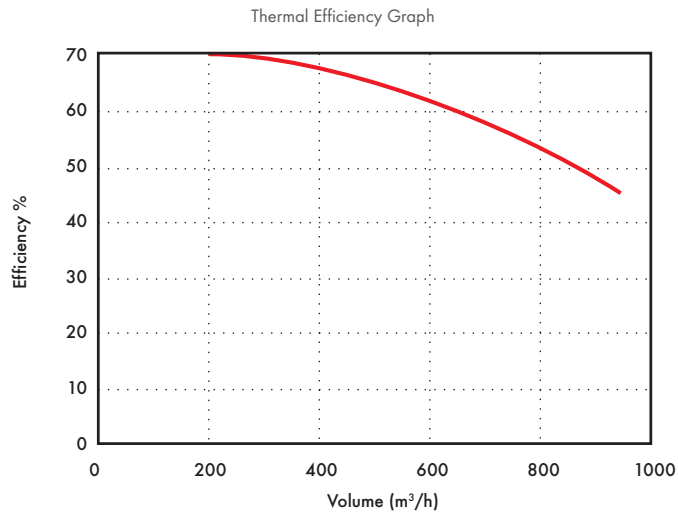
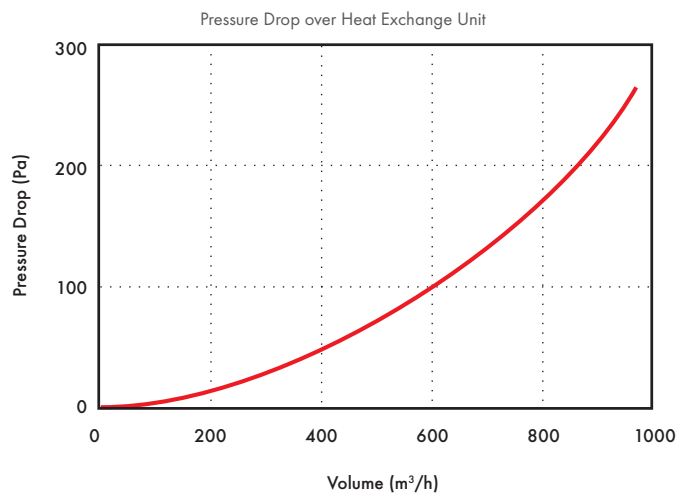

HR500DP

Features & Benefits

- Passive - no fans
- Lightweight, compact and easy to install
- Up to 70% heat recovery
- Easy to clean



A 'stand alone' heat exchange module which will transfer up to 70% of the outgoing heat to incoming air. Polymeric construction with spigots to suit 200, 250 and 315mm Ø flexible ductwork.

Module accessible for routine cleaning. Condensate outlet provided. Ideal for use in air conditioned environments.

The heat exchanger works at the same high efficiency, automatically keeping a cool room cool.

Performance of the Heat Exchange Unit: At 180l/s achieves 70% temperature efficiency (balanced airflow). Ideal for schools, pubs, offices and leisure industries.

Model

Model	Stock Ref
HR500DP	10538290

Spigot Sets

Model	Stock Ref
200mm Spigot set	10577315
200mm Spigot set	10578315
250mm Spigot set	10577315
250mm Spigot set	10578315
315mm Spigot set	10577315

Dimensions (mm)

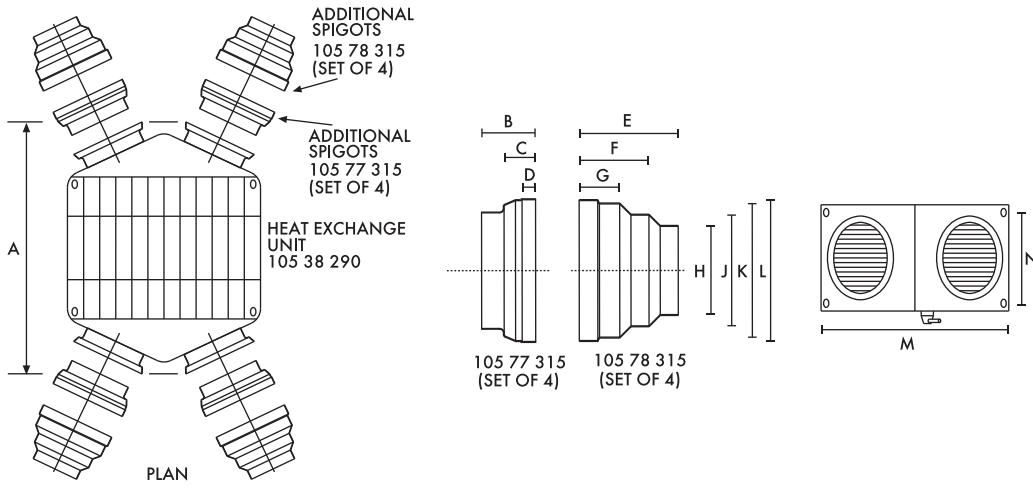

A	B	C	D	E	F	G	H	J	K	L	M	N
700	120	70	30	220	155	90	Ø200	Ø250	Ø300	Ø315	600	340

Weight: 9kg

Performance

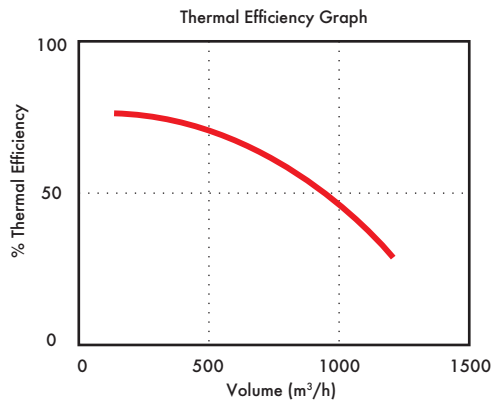
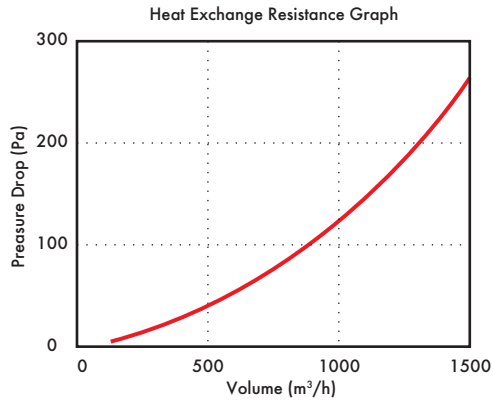

Ducting & Fittings



Since 1936, Vent-Axia have been known for providing a complete ventilation solution. This has not changed, and now we offer one of the widest ranges of ancillaries available today.

Vent-Axia

Vent-Axia
Lo-Carbon
Approved
Installer

	Arterial Duct System	150-151
	Uniflexplus+ Semi-Rigid Duct System	152-153
	Universal Roof Vents	154-155
	Internal Fit Wall Kit	156
	Low Resistance Inlet/Outlet Air Brick	157
	Ducting & Accessories	158-165
	Galvanised Spiral Wound Ducting	166
	Fire Stopping - Round and Flat Ducting	167
	100mm & 150mm Accessories	168-171

Arterial Duct System

Features & Benefits

- Reduces installation time
- Can be applied in SAP as a rigid duct system
- Crush resistant semi-rigid duct
- Unique low-resistance manifolds
- Simple installation through joists
- Smooth inner surface with antistatic and antibacterial coating
- Combines the advantages of rigid ducting with the versatility of a semi-rigid system



Arterial System

Vent-Axia is pleased to introduce the latest addition to our innovative range of ventilation ancillaries. For use with MVHR systems, the NEW Arterial air distribution system provides a flexible, highly robust solution, which can significantly reduce the installation time when compared to a standard system.

Rigid vs Semi-Rigid Systems

Both traditional duct types have limitations in modern construction.

Rigid systems: Passing rigid duct through a floor cassette at right-angles to the joists is time consuming and multiple connections increase the risk of leaking ductwork.

Semi-rigid Systems: It can often be difficult to accommodate two distribution boxes and multiple semi-rigid pipe runs in new buildings and the time saving advantages are soon overtaken by the additional cost of materials.

Reduced Installation Time

The Vent-Axia Arterial range combines the advantages of semi-rigid and traditional rigid ducting in one simple system. The system is independently tested and can be applied in SAP as a standard rigid system. Drops between floors to/from the MVHR unit remain in rigid PVC, having the advantage of low space usage and low cost. Traversing through joists in a floor cassette is much simpler and faster when using semi-rigid duct. The secret to the Arterial System is the unique low-resistance distribution plenum (Patent Pending) which is sited between joists allowing connection between semi-rigid and rigid sections.

Single Spigot Adaptor



Stock Ref	Duct Size	External Dimensions		
		A	B	C
408872	220x90 to 78Ø	94	258	150

Double Connector Plate



Stock Ref	Duct Size	External Dimensions		
		A	B	C
408873	220x90 to 78Ø	98	226	66

Single Connector Plate



Stock Ref	Duct Size	External Dimensions		
		A	B	C
408874	220x90 to 78Ø	98	226	66

Blank Plate



Stock Ref	Duct Size	External Dimensions		
		A	B	C
408875	220x90 to 78Ø	98	226	26

Reducer



Stock Ref	Duct Size	External Dimensions		
		A	B	C
408885	120 to 78Ø	129	105	129

Semi-Rigid Ducting



Stock Ref	Duct Size	Length (mm)
406588	90mmØ (78mm ID)	20m

Complete System Setup Example

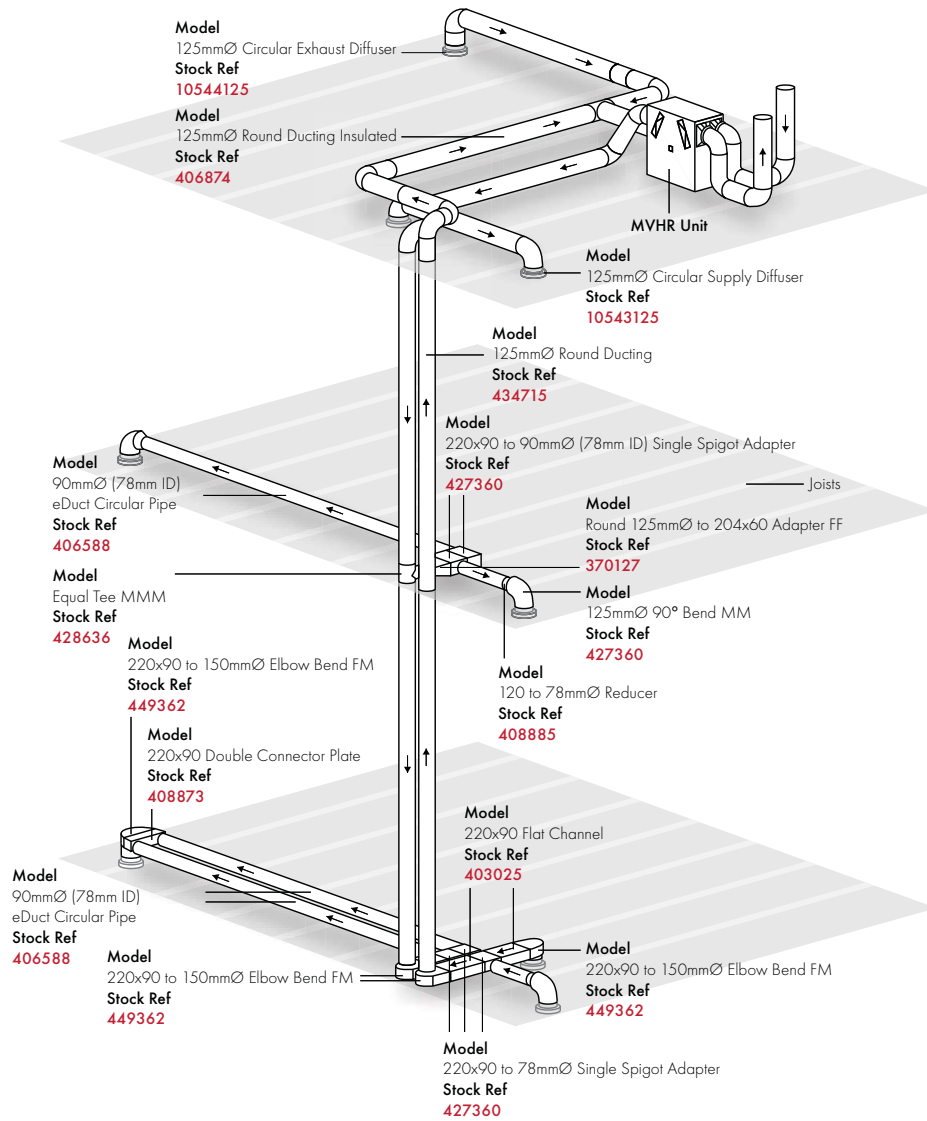

System Configuration Examples

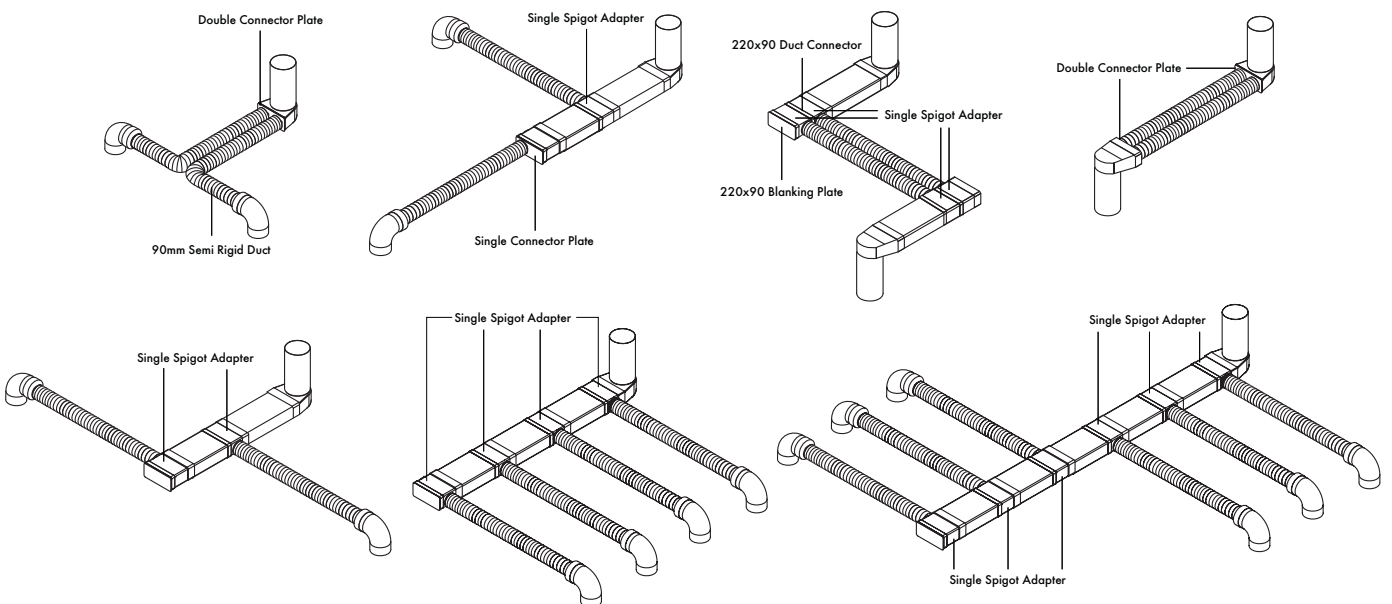

Uniflexplus+ Semi-Rigid Duct System

Features & Benefits

- Highly flexible and robust
- Extremely crush resistant
- Quick and easy to install
- PCDB listed
- Ideal for installation in concrete
- Corrosion proof
- Smooth inner surface with antistatic and antibacterial coating
- Low profile system - suitable for tight spaces
- Independently tested and accredited for air tightness



Uniflexplus+ Semi-Rigid Range

The new Uniflexplus+ Semi-Rigid Range sets the standard for easy to install, low profile ducting solutions. The system gives all of the flexibility that semi-rigid ducting provides - without taking up vital space. With minimal components, the system is uncomplicated to ensure a hassle-free, speedy install.

The Uniflexplus+ Semi-Rigid Range is compatible with most wholehouse ventilation systems including the Lo-Carbon Sentinel Kinetic Range (MVHR).

Models



90° Valve Collector

The 90° Valve Collector connects a section of 125mm diameter ducting and turns 90° into 2 spigots to connect to the semi rigid - ideal for dropping semi-rigid into ceiling diffusers.

Duct Size	Stock Ref
2xØ90 - Ø125mm	472248
1xØ90 - Ø125mm	472249
2xØ75 - Ø125mm	472255



Straight Valve Collector

The straight valve collector takes 125mm ducting and turns it straight into 2 spigots to connect to semi-rigid.

Model	Stock Ref
2xØ75mm - Ø125mm	472261
2xØ90mm - Ø125mm	472262



Semi-Rigid Ducting

Suitable for installation in concrete ceilings, suspended ceilings, internal walls, risers or frames, the Semi-Rigid Ducting is double-walled providing optimum flexibility. With an antistatic and antibacterial coating, the internal surface of the Semi-Rigid Ducting is smooth to ensure minimal resistance to airflow. Admissible operating temperature: -25°C to 60°C.

O/I Ømm	Length m	Coil Ømm	Coil Height		Weight kg
			mm		
75/63	50	1100	350		17
90/78	50	1130	250		9

Pipe Size	Stock Ref
75mmØ x 50m	406587
90mmØ x 50m	406588



Distribution Box

The low-profile distribution box runs a central spigot of diameter 125mm into a set of either 8 or 12 sub-spigots, depending on requirements. Available with either 75mm or 90mm semi-rigid spigots.

Model	Stock Ref
12xØ90 - Ø125mm	472250
8xØ90 - Ø125mm	472251
12xØ75 - Ø125mm	472256
8xØ75 - Ø125mm	472257

Accessories

Circular Extract Diffusers

Duct Size Stock Ref
125mmØ **10544125**

Circular Supply Diffusers

Duct Size Stock Ref
125mmØ **10543125**

Duct Knife

Duct Size Stock Ref
Ø90mm **472252**
Ø75mm **472258**

90° Bend

Duct Size Stock Ref
Ø90mm **472253**
Ø75mm **472259**

Coupler

Duct Size Stock Ref
Ø90mm **472254**
Ø75mm **472260**

Complete System Setup Examples

The distribution boxes can be mounted vertically on a wall or fixed horizontally onto a ceiling slab to achieve a solution tailored to your need. At a depth of just 90mm, the distribution boxes offer a considerably low-profile solution - they can then be combined with various components to suit on-site needs.

Semi-Rigid ducting is run from distribution boxes and ancillaries to respective rooms in the dwelling. Connecting the Semi-Rigid ducting to components is exceptionally straightforward to allow speedy installation - simply turn the ducting into the spigot until it clicks twice to achieve an airtight mechanical seal.

Rigid or flexible 125mm diameter ducting is then run from the MVHR unit to the distribution box.

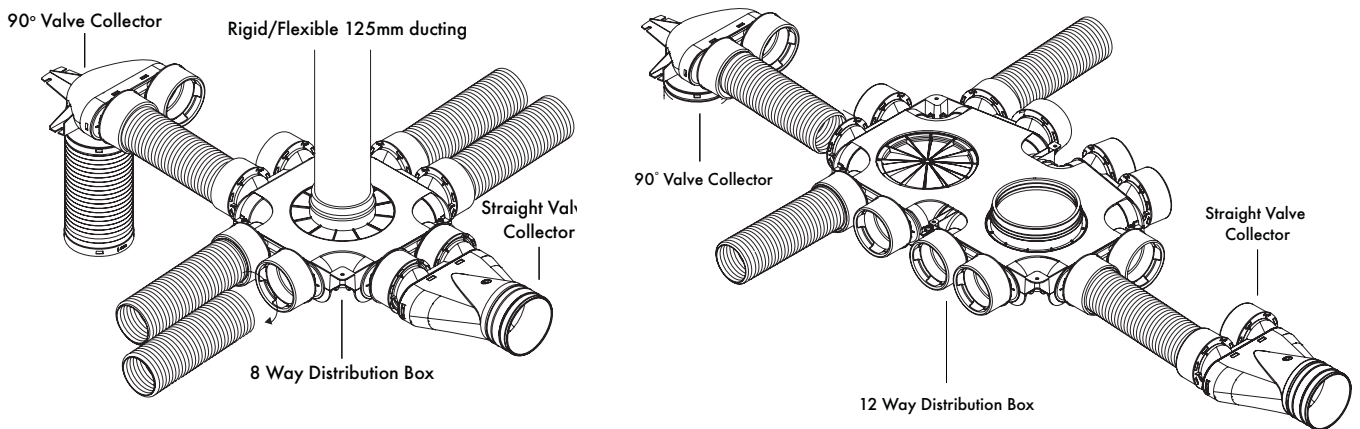

Universal Roof Vents

Features & Benefits

- Models available for both pitched and flat roof types
- Complies with Building Regulations
- Suitable for most installations
- Corrosion and weather proof
- Compatible with both mechanical and natural ventilation systems
- Three colours available for pitched roof vents



Wholehouse ventilation systems require termination to the external atmosphere, often through the roof. To ensure that the ventilation system is able to achieve its optimum level of performance, it is important that a suitable roof termination product is installed.

With this in mind, Vent-Axia is pleased to introduce a range of Universal Roof Vents; including products suitable for both pitched and flat roof types.

A selection of colours and sizes should ensure that our range offers a product suitable for most residential applications with a pitched or flat roof.

Models



Universal Roof Vent suitable for Pitched Roofs

Manufactured in the UK, these products have been specifically developed for use with both natural and mechanical ventilation systems.

All models have been independently tested by the BRE to BS476 Part 3: 2004 and have been awarded an AA classification - the highest possible. Thus they can be installed without restriction on any pitched roof.

All models have low resistances to airflow (see table) and incorporate condensation grooves to prevent any condensate running back down the duct. Universal Roof Vents are designed to resist the ingress of deluge and driving rain.

Universal Roof Vents (pitched roof models) are suitable for roof pitches between 20° and 60°.

The pitched roof vents are available as a 'tiled' roof vent to fit alongside most traditional roof tiles, as well as a 'slate' version which can be easily cut down to fit alongside all traditional roof slates. Pitched roof vents are available in a variety of colours as detailed in the Specification Table overleaf - custom colour and textured vents to match your exact needs are also available at an extra charge.



Universal Roof Vent suitable for Flat Roofs

Capped stacks for use in asphalt and built-up felt roofs. Special low air resistance cowl - the pressure/airflow resistance is <math><1.0</math> Pascal at 63 l/s. The pipework above the roofline is twin walled and incorporates an integral condensation drain. The stack pipe has an integral collar and separate aluminium flange for use with both felt and asphalt roof finishes.

All Vent-Axia Universal Roof Vents have a free area exceeding those required by building regulations.

Specification

Stock Ref	Roof Type	Tile Type	Spigot Size mm	Colour	Airflow Resistance (Pa) at l/s				
					14	28	56	83	140
407329	Pitched	Tile	125	Red	1.1	4.1	16.8	N/A	N/A
407330	Pitched	Tile	125	Brown	1.1	4.1	16.8	N/A	N/A
407331	Pitched	Tile	125	Grey	1.1	4.1	16.8	N/A	N/A
407332	Pitched	Tile	150	Red	0.3	1.0	4.2	9.5	27.4
407333	Pitched	Tile	150	Brown	0.3	1.0	4.2	9.5	27.4
407334	Pitched	Tile	150	Grey	0.3	1.0	4.2	9.5	27.4
407335	Pitched	Slate	125	Slate Blue/Black	1.1	4.1	16.8	N/A	N/A
407336	Pitched	Slate	150	Slate Blue/Black	0.3	1.0	4.2	9.5	27.4

Stock Ref	Roof Type	Colour	Free vent area mm ²	Pressure/air-flow resistance	Diameter mm	Height above roof mm	Flange diameter mm	Depth
								below flange mm
407337	Flat	Black	8,400	<1.0	110	300	395	350
407338	Flat	Black	12,000	<1.0	131	400	450	350
407339	Flat	Black	20,000	<1.0	166	540	450	510

Internal Fit Wall Kit

Features & Benefits

- Ideal for high-rise applications
- Suitable for 100mm fans
- Quick & easy installation
- Extendable length
- Fits from inside the property
- Prevents water ingress
- Includes low-resistance external grille
- Suitable as a passive air grille
- Covers external break-out

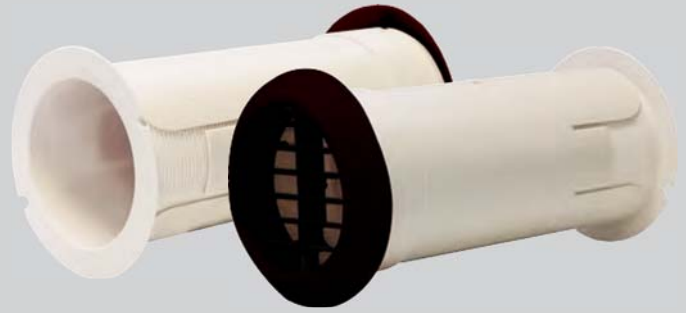

Internal Fit Wall Kit

The NEW Internal Fit Wall Kit is designed to simplify installation and improve the finish of 100mm through the wall installations, also providing an external grille and water ingress protection shroud.

High Rise Buildings

The Kit can be fully installed from inside the building, significantly reducing the cost and complexity associated with these sites. After core-drilling a 117mm hole, or utilising an appropriate existing hole, the Kit simply pushes through from the inside of the building. Spring pins secure the external grille in position and the external shroud deploys around the grille covering up break-out from the external surface.

Installer Friendly

The internal flange thickness is minimised to allow a variety of fans or grilles to be installed and indicators on both the external grill and internal flange ensure perfect alignment. The tubes extend to accommodate wall thicknesses from 225mm up to 390mm and lock into position for a secure fit. The internal flange is also flexible enough to accommodate deviations in the internal surface finish.

Building Regulations

The external grille free area is greater than 90% of the area of the duct making it suitable for continuous running systems as well as for intermittent fans.

Models

Model	Stock Ref
White	472318
Brown	472319

Dimensions (mm)

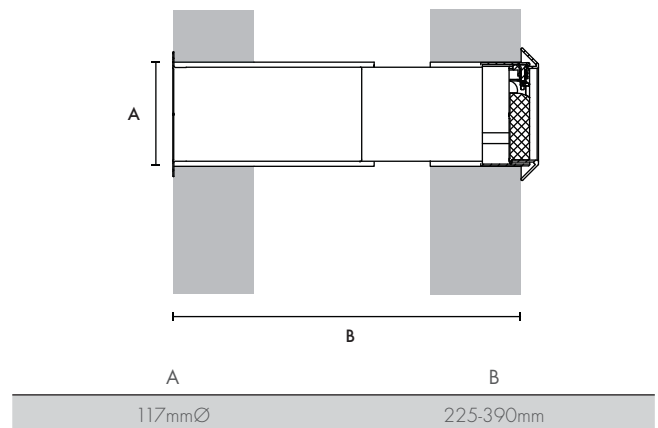

Low Resistance Inlet/Outlet Air Brick

Features & Benefits

- Provides over 90% free area of duct
- Easier to install than a double air brick
- Guide vanes for improved duct connection
- Optional first fix duct section



Available in five colours, this low resistance air brick has been designed to comply with the latest Building Regulations Approved Document F, which requires a ventilation outlet to achieve a minimum of 90% of the cross sectional area of the ductwork.

Installing a single air brick is much simpler than a double air brick and offers more versatility for locations.

Suitable for installation with round 100mm and 125mm diameter and rectangular 204 x 60mm ducting.

Attaching duct to the air brick is simplified by the use of guide vanes which help locate the duct onto the spigot.

A 500mm section of 204 x 60 duct is available for first fix which ensures that connections are accessible after completion of building works.

Five colour options ensure that the low resistance air brick will be a match for almost any application.

Models

Model	Stock Ref
White	449223
Brown	449224
Cotswold Stone	449225
Grey	449226
Terracotta	449227
1st Fix duct section 500 x 204 x 60	403255

Available Colours



Performance Guide

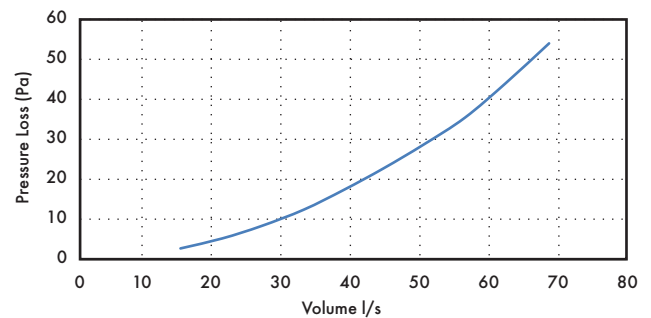

Pressure (Pa)	Volume (m ³ /h)	Volume (l/s)
2.7	53.7	14.9
5.2	75.9	21.1
8.3	97.0	26.9
12.4	119.4	33.2
17.4	141.0	39.2
22.7	162.0	45.0
28.7	183.7	51.0
35.4	205.6	57.1
44.1	227.6	63.2
54.0	250.4	69.6

Dimensions (mm)

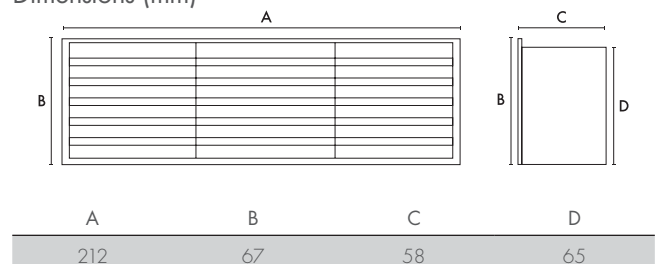

Ducting & Accessories

Flat Channel 1.5 Metre Length



Stock Ref	Duct Size	External Dimensions			Resistance (Pa) at flow rate								
		A	B	C	8 l/s	13 l/s	21 l/s	29 l/s	37 l/s	45 l/s	53 l/s	61 l/s	
406870	Insulated 204 x 60*	160	304	1500	<1	<1	1.3	2.2	3.3	4.5	5.9	7.8	
436617	Uninsulated 204 x 60	60	204	1500	<1	<1	1.3	2.2	3.3	4.5	5.9	7.8	
436599	Uninsulated 110 x 54	54	110	1500	1.2	2.4	5.3	9.1	13.9	19.8	25.9	32	
Stock Ref	Duct Size	A	B	C	60 l/s			120 l/s			180 l/s		
407343	Insulated 220 x 90*	190	320	1500	1.4			4.9			10.2		
403025	Uninsulated 220 x 90	90	220	1500	1.4			4.9			10.2		

Flat Channel Connector. F to F



Stock Ref	Duct Size	External Dimensions			Resistance (Pa) at flow rate								
		A	B	C	8 l/s	13 l/s	21 l/s	29 l/s	37 l/s	45 l/s	53 l/s	61 l/s	
436623	204 x 60	64	212	100	<1	<1	<1	<1	<1	<1	1.2	1.5	
436605	110 x 54	54	114	100	<1	<1	1.1	1.4	2.2	3.4	4.8	6.4	
Stock Ref	Duct Size	A	B	C	60 l/s			120 l/s			180 l/s		
403026	220 x 90	95	224	52	<1			<1			<1		

Channel Fixing Clip (Pack of 10)



Stock Ref	Duct Size	External Dimensions			Resistance (Pa) at flow rate								
403030	220 x 90	A	B	C	60 l/s			120 l/s			180 l/s		
		97	44	19	N/A			N/A			N/A		

Horizontal 90° Bend. F to F



Stock Ref	Duct Size	External Dimensions			Resistance (Pa) at flow rate								
		A	B	C	8 l/s	13 l/s	21 l/s	29 l/s	37 l/s	45 l/s	53 l/s	61 l/s	
406879	Insulated 204 x 60*	160	360	360	0.7	1.7	4.1	8.4	13	18	25	34	
436620	Uninsulated 204 x 60	65	260	260	0.7	1.7	4.1	8.4	13	18	25	34	
436602	Uninsulated 110 x 54	60	152	152	2.3	9.9	21	38	64	93	124	162	
Stock Ref	Duct Size	A	B	C	60 l/s			120 l/s			180 l/s		
407342	Insulated 220 x 90*	190	350	350	9			36			80		
403028	Uninsulated 220 x 90	95	250	250	9			36			80		

Horizontal 45° Bend. F to F

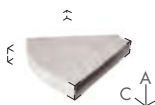

Stock Ref	Duct Size	External Dimensions			Resistance (Pa) at flow rate								
		A	B	C	8 l/s	13 l/s	21 l/s	29 l/s	37 l/s	45 l/s	53 l/s	61 l/s	
406876	Insulated 204 x 60*	160	340	360	0.2	0.7	1.2	2.1	3.8	6.1	9.2	13	
249944	Uninsulated 204 x 60	65	240	260	0.2	0.7	1.2	2.1	3.8	6.1	9.2	13	
Stock Ref	Duct Size	A	B	C	60 l/s			120 l/s			180 l/s		
449363	Uninsulated 220 x 90	95	240	200	5			20			46		

*Minimum insulation wall thickness 25mm. Insulation Thermal Conductivity: 0.04 W/(m.K)

Horizontal T. F to F to F



Stock Ref	Duct Size	External Dimensions			Resistance (Pa) at flow rate								
		A	B	C	8 l/s	13 l/s	21 l/s	29 l/s	37 l/s	45 l/s	53 l/s	61 l/s	
406883	Insulated 204 x 60*	160	410	355	vary on installation								
436551	Uninsulated 204 x 60	65	310	255	vary on installation								
436614	Uninsulated 110 x 54	60	185	150	vary on installation								
Stock Ref	Duct Size	A	B	C	60 l/s			120 l/s			180 l/s		
449365	Uninsulated 220 x 90	95	275	250				vary on installation					

Vertical 90° Bend. F to F



Stock Ref	Duct Size	External Dimensions			Resistance (Pa) at flow rate								
		A	B	C	8 l/s	13 l/s	21 l/s	29 l/s	37 l/s	45 l/s	53 l/s	61 l/s	
406872	Insulated 204 x 60*	215	310	215	1.1	2.5	5.2	9.8	16.1	24	33.6	45	
436621	Uninsulated 204 x 60	115	210	115	1.1	2.5	5.2	9.8	16.1	24	33.6	45	
436603	Uninsulated 110 x 54	95	115	95	3.3	15.5	36	61	96	138	190	253	
Stock Ref	Duct Size	A	B	C	60 l/s			120 l/s			180 l/s		
403029	Uninsulated 220 x 90	117	224	120	7			28			66		

Vertical 45° Bend. F to F



Stock Ref	Duct Size	External Dimensions			Resistance (Pa) at flow rate								
		A	B	C	8 l/s	13 l/s	21 l/s	29 l/s	37 l/s	45 l/s	53 l/s	61 l/s	
406871	Insulated 204 x 60*	200	310	215	0.1	0.5	1.3	2.5	4.4	6.9	10	13.3	
445196	Uninsulated 204 x 60	100	210	115	0.1	0.5	1.3	2.5	4.4	6.9	10	13.3	
441655	Uninsulated 110 x 54	115	115	70	1	2.4	6.6	12.9	23.1	35.1	48	64	
Stock Ref	Duct Size	A	B	C	60 l/s			120 l/s			180 l/s		
449364	Uninsulated 220 x 90	110	225	115	6			27			65		

Elbow Bend. 100mm to Rectangular. M to F



Stock Ref	Duct Size	External Dimensions			Resistance (Pa) at flow rate								
		A	B	C	8 l/s	13 l/s	21 l/s	29 l/s	37 l/s	45 l/s	53 l/s	61 l/s	
436624	204 x 60	80	215	195	2.9	7.1	15.1	28	45.1	68.1	92.2	118	
436607	110 x 54	90	115	140	3	8	17.7	33	49.9	74.5	101	137	
Stock Ref	Duct Size	A	B	C	60 l/s			120 l/s			180 l/s		
403027	220 x 90	118	226	240	N/A			N/A			N/A		

Elbow Bend. 125mm to Rectangular. M to F



Stock Ref	Duct Size	External Dimensions			Resistance (Pa) at flow rate								
		A	B	C	8 l/s	13 l/s	21 l/s	29 l/s	37 l/s	45 l/s	53 l/s	61 l/s	
436625	204 x 60	80	215	195	3.1	5.9	12.2	25	43.6	62.2	86	111	
Stock Ref	Duct Size	A	B	C	60 l/s			120 l/s			180 l/s		
449361	220 x 90	118	226	240	N/A			N/A			N/A		

*Minimum insulation wall thickness 25mm. Insulation Thermal Conductivity: 0.04 W/(m.K)

Ducting & Accessories

Elbow Bend. 150mm to Rectangular. M to F



Stock Ref	Duct Size	External Dimensions			Resistance (Pa) at flow rate									
		A	B	C	8 l/s	13 l/s	21 l/s	29 l/s	37 l/s	45 l/s	53 l/s	61 l/s		
436626	204 x 60	80	215	195	2.8	4.9	11.6	21	31	41	53	67		
Stock Ref	Duct Size	A	B	C	60 l/s		120 l/s				180 l/s			
449362	220 x 90	118	226	240	N/A		N/A				N/A			

Elbow Bend. 100mm to Rectangular. F to F

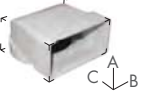

Stock Ref	Duct Size	External Dimensions			Resistance (Pa) at flow rate									
		A	B	C	8 l/s	13 l/s	21 l/s	29 l/s	37 l/s	45 l/s	53 l/s	61 l/s		
436608	110 x 54	90	115	140	2.1	5.5	14.3	27.2	44.3	69	93	118		

Flat Channel connector with Damper



Stock Ref	Duct Size	External Dimensions			Resistance (Pa) at flow rate									
		A	B	C	8 l/s	13 l/s	21 l/s	29 l/s	37 l/s	45 l/s	53 l/s	61 l/s		
400735	110 x 54	60	115	75	16	17.5	19.5	22	25.5	30.5	36	42		

Drop down section F to F



Stock Ref	Duct Size	External Dimensions			Resistance (Pa) at flow rate									
		A	B	C	8 l/s	13 l/s	21 l/s	29 l/s	37 l/s	45 l/s	53 l/s	61 l/s		
442273	204 x 60	120	220	210	0.2	0.5	1.7	3.6	6.0	9.1	12.4	16.6		

Single Air Brick Horizontal (System 60 Air Grille Adaptor is supplied with the Single Air Bricks)

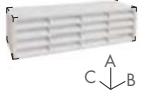

Stock Ref	Duct Size	External Dimensions			Resistance (Pa) at flow rate									
		A	B	C	8 l/s	13 l/s	21 l/s	29 l/s	37 l/s	45 l/s	53 l/s	61 l/s		
436610	110 x 54 (White)	65	210	85	3.2	7.8	20.9	39	65	96	128	176		
436612	110 x 54 (Terracotta)	65	210	85	3.2	7.8	20.9	39	65	96	128	176		
436611	110 x 54 (Brown)	65	210	85	3.2	7.8	20.9	39	65	96	128	176		
436613	110 x 54 (Beige)	65	210	85	3.2	7.8	20.9	39	65	96	128	176		

Single Air Grille Soldier



Stock Ref	Duct Size	External Dimensions			Resistance (Pa) at flow rate									
		A	B	C	8 l/s	13 l/s	21 l/s	29 l/s	37 l/s	45 l/s	53 l/s	61 l/s		
438594	204 x 60 (White)	210	65	15	3.3	10	20.6	40	63	92.8	128	168		
468728	204 x 60 (Terracotta)	210	65	15	3.3	10	20.6	40	63	92.8	128	168		
468730	204 x 60 (Brown)	210	65	15	3.3	10	20.6	40	63	92.8	128	168		
468729	204 x 60 (Beige)	210	65	15	3.3	10	20.6	40	63	92.8	128	168		

Double Air Brick



Stock Ref	Duct Size	External Dimensions			Resistance (Pa) at flow rate								
		A	B	C	8 l/s	13 l/s	21 l/s	29 l/s	37 l/s	45 l/s	53 l/s	61 l/s	
438604	204 x 60 (White)	145	245	80	0.2	1.6	4.3	8.7	13.9	21.1	27.5	37.4	
438607	204 x 60 (Terracotta)	145	245	80	0.2	1.6	4.3	8.7	13.9	21.1	27.5	37.4	
438605	204 x 60 (Brown)	145	245	80	0.2	1.6	4.3	8.7	13.9	21.1	27.5	37.4	
438606	204 x 60 (Beige)	145	245	80	0.2	1.6	4.3	8.7	13.9	21.1	27.5	37.4	

Double Air Brick Adaptor

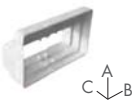

Stock Ref	Duct Size	External Dimensions			Resistance (Pa) at flow rate								
		A	B	C	8 l/s	13 l/s	21 l/s	29 l/s	37 l/s	45 l/s	53 l/s	61 l/s	
438608	204 x 60	135	220	85	-	-	-	-	-	-	-	-	

Air Grille Adaptor

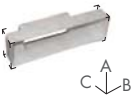

Stock Ref	Duct Size	External Dimensions			Resistance (Pa) at flow rate								
		A	B	C	8 l/s	13 l/s	21 l/s	29 l/s	37 l/s	45 l/s	53 l/s	61 l/s	
436609	110 x 54	65	210	85	0.2	1.2	2.5	4.7	7.8	11	14	18	

Flexible Ducting



Stock Ref	Duct Size	External Dimensions			Resistance (Pa) at flow rate								
		A	B	C	8 l/s	13 l/s	21 l/s	29 l/s	37 l/s	45 l/s	53 l/s	61 l/s	
5109662	204 x 60	-	-	-	0.2	0.6	1.5	2.6	4.1	6.0	8.2	11.5	
449366	220 x 90	-	-	-	60 l/s		120 l/s			180 l/s			
					N/A		N/A			N/A			

Louved Grille with Flyscreen Fitting

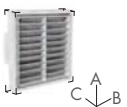

Stock Ref	Duct Size	External Dimensions			Resistance (Pa) at flow rate								
		A	B	C	8 l/s	13 l/s	21 l/s	29 l/s	37 l/s	45 l/s	53 l/s	61 l/s	
400743	110 x 54	140	140	50	5.7	14.5	37	75	120	-	-	-	

Round (M) 100mm to Rectangular (F/M) Adaptor



Stock Ref	Duct Size	External Dimensions			Resistance (Pa) at flow rate								
		A	B	C	8 l/s	13 l/s	21 l/s	29 l/s	37 l/s	45 l/s	53 l/s	61 l/s	
441654	M to F 204 x 60	140	210	215	1.0	1.96	3.2	4.9	6.7	8.7	11.2	14.5	
400740	M to M 110 x 54	100	115	180	1.2	4.2	8.3	19.8	29.9	42	60	86	

Ducting & Accessories

Round (F) 125mm to Rectangular (F) Adaptor



Stock Ref	Duct Size	External Dimensions			Resistance (Pa) at flow rate							
		A	B	C	8 l/s	13 l/s	21 l/s	29 l/s	37 l/s	45 l/s	53 l/s	61 l/s
370127	204 x 60	140	210	213	<1	<1	1.5	2.8	4.5	6.7	9	11.5

Round (F) 150mm to Rectangular (F) Adaptor



Stock Ref	Duct Size	External Dimensions			Resistance (Pa) at flow rate		
		A	B	C	60 l/s	120 l/s	180 l/s
403031	220 x 90	160	225	203	N/A	N/A	N/A

Short Round (M) 100mm to 110 x 54 (F) Adaptor



Stock Ref	Duct Size	External Dimensions			Resistance (Pa) at flow rate							
		A	B	C	8 l/s	13 l/s	21 l/s	29 l/s	37 l/s	45 l/s	53 l/s	61 l/s
455035	110 x 54	60	110	105	1.2	4.3	8.4	20	30.2	43	62	88

Round 2m Ducting length Insulated/Uninsulated



Stock Ref	Duct Size	External Dimensions			Resistance (Pa) at flow rate							
		A	B	C	8 l/s	13 l/s	21 l/s	29 l/s	37 l/s	45 l/s	53 l/s	61 l/s
406873	Insulated 100 Ø*	200	200	2000	<1	<1	1.7	2.8	3.6	4.5	5.3	6.2
5108250	Uninsulated 100 Ø	100	100	2000	<1	<1	1.7	2.8	3.6	4.5	5.3	6.2
406874	Insulated 125 Ø*	225	225	2000	<1	<1	<1	1.3	1.8	2.4	3.1	3.8
434715*	Uninsulated 125 Ø	125	125	1500	<1	<1	<1	1.3	1.8	2.4	3.1	3.8
406875	Insulated 150 Ø*	265	265	2000	<1	<1	<1	<1	1.2	1.6	2	2.5
5108248	Uninsulated 150 Ø	150	150	2000	<1	<1	<1	<	1.2	1.6	2	2.5

*1.5 metres

Equal Tee Insulated/Uninsulated MMM



Stock Ref	Duct Size	External Dimensions			Resistance (Pa) at flow rate							
		A	B	C	8 l/s	13 l/s	21 l/s	29 l/s	37 l/s	45 l/s	53 l/s	61 l/s
406884	Insulated 100 Ø*	290	210	235	vary on installation							
372007	Uninsulated 100 Ø	190	110	135	vary on installation							
406885	Insulated 125 Ø*	310	215	260	vary on installation							
428636	Uninsulated 125 Ø	210	115	160	vary on installation							
406886	Insulated 150 Ø*	335	245	285	vary on installation							
370237	Uninsulated 150 Ø	235	130	177	vary on installation							

*Minimum insulation wall thickness 25mm. Insulation Thermal Conductivity: 0.04 W/(m.K)

90° Bend Insulated/Uninsulated MM

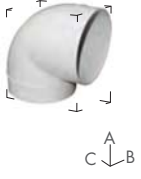

Stock Ref	Duct Size	External Dimensions			Resistance (Pa) at flow rate								
		A	B	C	8 l/s	13 l/s	21 l/s	29 l/s	37 l/s	45 l/s	53 l/s	61 l/s	
406880	Insulated 100 Ø*	230	200	200	2.8	5.5	11	20.3	33	45	60	79	
372004	Uninsulated 100 Ø	130	100	100	2.8	5.5	11	20.3	33	45	60	79	
406881	Insulated 125 Ø*	260	230	230	<1	1.8	5	8.2	11.8	18	26	35	
427360	Uninsulated 125 Ø	160	130	130	<1	1.8	5	8.2	11.8	18	26	35	
406882	Insulated 150 Ø*	290	255	255	<1	1.0	2.5	4.1	6.4	9.6	13.5	18	
370295	Uninsulated 150 Ø	190	155	155	<1	1.0	2.5	4.1	6.4	9.6	13.5	18	

45° Bend Insulated/Uninsulated MM



Stock Ref	Duct Size	External Dimensions			Resistance (Pa) at flow rate								
		A	B	C	8 l/s	13 l/s	21 l/s	29 l/s	37 l/s	45 l/s	53 l/s	61 l/s	
406877	Insulated 100 Ø*	280	200	230	<1	1.9	8.1	11.7	17.5	24.6	31.4	-	
372005	Uninsulated 100 Ø	180	100	130	<1	1.9	8.1	11.7	17.5	24.6	31.4	-	
406878	Insulated 125 Ø*	300	230	250	<1	<1	1.8	2.9	4.6	6.6	9	12.2	
441657	Uninsulated 125 Ø	200	130	150	<1	<1	1.8	2.9	4.6	6.6	9	12.2	

Connector MM



Stock Ref	Duct Size	External Dimensions			Resistance (Pa) at flow rate								
		A	B	C	8 l/s	13 l/s	21 l/s	29 l/s	37 l/s	45 l/s	53 l/s	61 l/s	
372006	100 Ø	100	60	-	-	-	-	-	-	-	-	-	
428633	125 Ø	125	60	-	-	-	-	-	-	-	-	-	
370299	150 Ø	150	60	-	-	-	-	-	-	-	-	-	

Reducer



Stock Ref	Duct Size	External Dimensions			Resistance (Pa) at flow rate								
		A	B	C	8 l/s	13 l/s	21 l/s	29 l/s	37 l/s	45 l/s	53 l/s	61 l/s	
VA54119	125mm to 100mm	130	57	-	-	-	-	-	-	-	-	-	
428632	150mm to 125mm	155	57	-	-	-	-	-	-	-	-	-	

*Minimum insulation wall thickness 25mm. Insulation Thermal Conductivity: 0.04 W/(m.K)

Ducting & Accessories



PVC Flexible Ducting

Manufactured using PVC with wire helix. Used with single spigots and in multi-duct schemes.

6 metre lengths

Duct Dia	Stock Ref
100mm	436580
125mm	436584
150mm	436588
200mm	436592

T-Series Flexible Ducting

PVC with wire helix. For use with T-Series.

6m lengths

Size	Duct Dia	Stock Ref
Size 6	175mm	566607
Size 7	225mm	566609
Size 9	300mm	566612
Size 12	400mm	566616



Insulated Flexible Ducting

Insulated ducting should be used when duct passes through an unheated area. Minimised heat loss when used with heat recovery fans. Available in 6 diameters. An additional benefit is that thermally insulated duct offers some measure of acoustic attenuation.

Fire Rating: When assessed against the integrity criterion of BS476: Part 20; 1987, the ducting is capable of providing in excess of 25 minutes integrity from inside to outside.

10 metre lengths

Duct Dia	Stock Ref
100mm	561654
125mm	561655
150mm	561656



Duct Y Pieces

For dividing a ventilation system, providing ducting to multiple supply or extract grilles using only a single fan source.

2x Into	1x	Stock Ref
100mm	100mm	452081
100mm	150mm	452082
125mm	125mm	455211
125mm	150mm	455212
150mm	150mm	452083
150mm	200mm	452084
200mm	200mm	452085
200mm	250mm	452078
250mm	250mm	452076
250mm	300mm	452079



Acoustic Insulated Ducting

Multiple layer aluminium/polyester laminate with micro perforated flexible core to enhance acoustic performance. Core surrounded by 25mm fibreglass insulation with outer vapour barrier.

Duct Dia	Length	Stock Ref
100mm	1m	443273
125mm	1.5m	443793
150mm	1m	443274



Reducer

Duct Size	Stock Ref
R125/100	370302
R150/100	370303
R150/125	370304
R200/150	370307
R250/200	370309
R300/100	370310
R300/200	370312



Circular Extract Diffusers

Manufactured from powder coated steel. Suitable for exhausting air and can be fitted directly to the duct or in the ceiling.

Duct Size	Stock Ref
100 Ø	10544100
125 Ø	10544125
150 Ø	10544150
200 Ø	10544200



Circular Supply Diffusers

Manufactured from powder coated steel. Suitable for supplying air and can be fitted directly to the duct or in the ceiling.

Duct Size	Stock Ref
100 Ø	10543100
125 Ø	10543125
150 Ø	10543150
200 Ø	10544200



Aircheck Bathroom Grille

An auto humidity operated extract grille. Constant airflow of 10m³/h opening to 45m³/h when humidity is detected. Additional PIR (presence detector) function with timer providing extract airflow rate of 45m³/h can be activated by adding 3 x AA batteries (not supplied) to the grille.

Stock Ref
407381



Collar for Exhaust & Supply Diffusers

Stock Ref
371301



Aircheck Kitchen Grille

An auto humidity operated extract grille. Constant airflow of 10 m³/h opening to 45m³/h when humidity is detected.

Further extract airflow rate of 135m³/h can be achieved using additional boost push button. Boost button controlled by 30 min overrun timer. 3 x AA batteries required (not supplied).

Stock Ref
407287

Boost Push Button

Stock Ref
448929



VT100 Tile Vent

5 in 1 roof ventilation terminal kit available in grey. The kit comprises of a streamlined hood on a circular upstand with a 500 x 500mm non lead skirt and a stepped adaptor which allows connections from 100mm to 160mm diameter ducting.

Stock Ref
370538



Aircheck Ceiling Adaptor (CA125)

A ceiling adaptor for connection between Aircheck grilles and ducting.

Model
CA125

Stock Ref
455219



Acoustic Mat

486mm x 486mm x 25mm thick foam mat for use as a resilient mounting for wholehouse units.

Model
ACM/House

Stock Ref
370179

Galvanised Spiral Wound Ducting



Spiral Ductwork - 3m length

Duct Size	Stock Ref
100 Ø	400900
125 Ø	400901
150 Ø	400902
200 Ø	410922
250 Ø	410923
315 Ø	410924



Joining Piece

In sheet metal. For joining lengths of flexible ducting to give long lasting airtight connection.

Duct Size	Stock Ref
100 Ø	561804
125 Ø	561805
150 Ø	561806
200 Ø	561808
250 Ø	561810
315 Ø	561813



Equal Tee

Duct Size	Stock Ref
100 Ø	400749
125 Ø	400750
150 Ø	400751
200 Ø	370238
250 Ø	370239
315 Ø	410925



Rectangular Balancing Damper

Duct Size	Stock Ref
110 x 54	405156
204 x 60	403698
220 x 90	403699



90° Bend

Duct Size	Stock Ref
100 Ø	400752
125 Ø	400753
150 Ø	400754
200 Ø	370202
250 Ø	370203
315 Ø	410926



Circular Balancing Damper

Duct Size	Stock Ref
100 Ø	400758
125 Ø	400759
150 Ø	400760
200 Ø	410930
250 Ø	410931
315 Ø	410932



Female Coupler

Duct Size	Stock Ref
100 Ø	400755
125 Ø	400756
150 Ø	400757
200 Ø	410927
315 Ø	410929

Fire Stopping – Round and Flat Ducting

Vent-Axia provides a complete range of fire stopping products specifically tested with ventilation ducting. This versatile selection allows for stacking and parallel installation in certain circumstances, along with creative solutions for partition walls and slab mounting.

The table highlights the type of fire stopping required for most common applications.

	Minutes Protection	Fire Valves		Round Fire Sleeve		
		100mm	125mm	100mm	125mm	150mm
130mm Stud Partition	30					
	60			407655	407656	407657
	120					
130mm Masonary	30					
	60			407655	407656	407657
	120					
140mm Masonary	30					
	60			407655	407656	407657
	120					
Ceilings	30					
	60	403431	403432			
	120					

	Minutes Protection	Rectangular Fire Sleeve			Rectangular Fire Wrap	
		110 x 54	204 x 60	220 x 90	110 x 54	204 x 60
72mm Stud Partition	30					
	60	407658	407659	407660		
	120					
100mm Stud Partition	30					
	60	407658	407659	407660		
	120					
130mm Stud Partition	30					
	60	407658	407659	407660	404276	404274
	120					
130mm Masonary	30					
	60	407658	407659	407660	435137	435138
	120					
140mm Masonary	30					
	60	407658	407659	407660	435137	435138
	120					

Fire Test Assessment also covers multiple flat ducts to be installed in series / side by side, max. 3No., 30, 60 & 120 Minute Partitions, Single & Double Boards.

Note: For a copy of the Fire Certificates for the product(s) above, visit our webpage www.vent-axia.com/range/ventilation-fire-stopping.

Vent-Axia does not guarantee compliance with Building Regulations Part B, Fire Spread or other regulations that relate to fire planning. Suitability to comply with these regulations should be determined prior to installation and in conjunction with Building Control Officers. Compliance with the Regulations is specifically excluded from quotations and designs.



Circular Fire Valve

Duct Size	Stock Ref
100mm	403431
125mm	403432
150mm	403433
200mm	408828



Round Fire Sleeve

Thickness:	10-15mm
Length:	280mm (180mm 407655)
CE Marked	
Duct Size	Stock Ref
100mm	407655
125mm	407656
150mm	407657



Rectangular Fire Sleeve - 4 sided

Thickness:	10-15mm
Length:	180mm
CE Marked	
Duct Size	Stock Ref
110x54mm	407658
204x60mm	407659
220x90mm	407660



Rectangular Fire Wrap

Duct Size	Stock Ref
204x60mm	435138



Pyrocheck

Duct Size	Stock Ref
4" Ø	CVT100
5" Ø	CVT130

100mm & 150mm Accessories



Wall Fitting Kit

A range of wall kits suitable for Vent-Axia range of 100 and 150mm fans. The kit can be installed into most walls using the telescopic liners supplied.

White	
Model	Stock Ref
VA100	254102
Silhouette 125	455226
VA140/150	140902
Silhouette 150	140902
Brown	
Model	Stock Ref
VA100	254100
VA140/150	140903
Silhouette 150	140903



Air Grille

Louvre grille for external termination of 100mm diameter rigid ducting. Consists of wall mounting piece and grille with 2 fixing screws.

Colour:	White or Brown
Dimensions:	155 x 155 x 32mm
Material:	ABS plastic

Colour	Stock Ref
White	563511
Brown	563500



Window Fitting Kit

For use in single or sealed double glazing and most materials up to 40mm thick.

White	
Model	Stock Ref
VA100 (105Ø)	254101
VA100 (110Ø)	443234
Centra/Sil 100	442947
VA140/150	140901
Solo Pro	11461685



Termination Set

Used as a decorative inlet grille or soffit termination set in conjunction with 100mm or 125mm diameter ducting. Two fixing screws supplied to secure grille to the spigot through material up to 25mm thick. Dimension 155mm x 155mm.

Colour:	White
Material:	ABS plastic

Stock Ref
563513



Decoration Frame

A decoration frame that converts old Centrif to new Centrif Duo without the need to redecorate. The frame can be used with Quadra and Centrif Duo Plus.

The frame is simply installed using two wall fixing screws, allowing the fan to be mounted via its standard mountings. Finished in a high moulded material plastic colour matched to the fan.

Color: White
Size: 386mm x 296 x 32 mm deep

Stock Ref
442551



Quick Fit 100mm Airflow Shutter

Shutter with gravity flaps to protect against backdraught. The spigot connects to 100mm rigid ducting using quick fix grips provided.

Dimensions: 155 x 155 x 20mm
Material: Plastic

Colour Stock Ref
White **563522**
Brown **563542**



Terminal Connector & Grille

Used for the termination of 100mm flexible ducting to the ceiling or wall of small areas, such as internal toilets.

Connector: Manufactured in high impact thermoplastic
Colour: Grey
Grille: ABS plastic eggcrate, white finish

Description Stock Ref
Grille **560846**
Connector **560856**

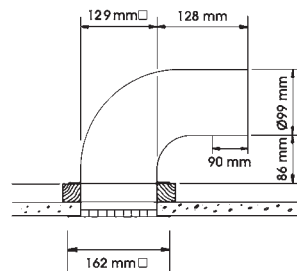

External Terminations louvre Grilles with Spigot

Plastic louvre grilles with either 100mm or 150mm diameter spigots.

100mm Ø Stock Ref
RD104TC **370328**
RD104BR **370329**
RD104WH **370330**

150mm Ø Stock Ref
RD604BR **370337**
RD604TC **370338**
RD604WH **370339**

100mm & 150mm Accessories



Quick Fit 100mm Grille

Terminates a rigid duct on an outside wall using the 'quick fix' side grips without the need for additional fixings.

Colour	Stock Ref
White	563521
Brown	563541



Vent Cowl

External termination for 110mm diameter rigid ducting through roofs and walls in exposed situations. Overall diameter 200mm. Not suitable for use with flexible ducting.

Material	Stock Ref
Grey PVCu	561403
White	457845



Quick Fix Termination

The quick fix termination is designed to be installed from inside the building to a nominal 117mm or 165mm diameter core-cut hole, saving time and cost. Four sealing rings ensures a weather tight fit to the wall external leaf. Effective length 370mm.

Duct Size	Stock Ref
100mm	563535
150mm	434656



Air Replacement Set

Bathroom and toilet ventilation is only effective when there is adequate air replacement into the room. This is often most effectively achieved by fitting a pair of air replacement grilles at low level in a door. Consists of a two piece telescopic set which fits unobtrusively on either side of the door panel.

Minimum fixing thickness:	30mm
Dimensions:	454 x 90mm
Hole size:	435 x 76mm
Material:	HIPS / High Impact Polystyrene
Free area:	16,600mm ²

Colour	Stock Ref
Brown	561400
Ivory	561401



Condensation Trap

Condensation trap, for fitting in vertical rigid PVCu pipe ducting. Must be used where pipe ducts pass through unheated roof voids. Fitted with 20mm pipe connection for running off condensate. Not suitable for use with flexible ducting.

Length	85mm
Material:	Grey PVCu

Size	Stock Ref
110mm	563516
125mm	455191
150mm	455190



Wind Baffles

A range of 100mm and 150mm wind baffles. Cowled wall outlet with damper protected gravity grille.

Available in white and brown they are ideal for exposed coastal applications, helping to prevent unwanted backdraughts.

100mm

Colour	Stock Ref
White	452094
Brown	452095

150mm

Colour	Stock Ref
White	452096
Brown	452097



VA140/150 Window wind cowl

Wind cowl for exposed areas.

Stock Ref

455262



Wind Baffle Kits

100mm wind baffle kit consisting of a telescopic wall tube and wind baffle. Available with either a white or brown wind baffle.

Colour	Stock Ref
White	407382
Brown	407577















Commercial Range



Lo-Carbon T-Series

The UK's No. 1 Commercial Fan is available with a low energy DC motor providing up to 65% energy saving. The motor is designed to provide longer life, improved performance, lower running costs and maintain the T-Series rugged reliability. Vent-Axia have improved the way this product can be purchased for the refurbishment market. As well as being able to purchase it as you always have, you can also purchase it as a fan core plus optional application specific fitting kit, which gives you more flexibility in both stocking and installing the product. It also supports our lo-carbon drive to reduce waste and landfill.

Vent-Axia®

	ACM 100-200	174-175
	ACM 250-315	176-177
	Powerflow Range	178-179
	Lo-Carbon T-Series Overview	180-181
	Lo-Carbon T-Series Window Fan	182-183
	Lo-Carbon T-Series Wall Fan	184-185
	Lo-Carbon T-Series Roof Fan	186-187
	Lo-Carbon T-Series Panel Fan	188-189
	Traditional T-Series Overview	190-191
	Traditional T-Series Window Fan	192-193
	Traditional T-Series Wall Fan	194-195
	Traditional T-Series Roof Fan	196-197
	Traditional T-Series Panel/Ceiling Fan	198-199
	Traditional T-Series Darkroom Fan	200-201
	Traditional T-Series In-line Fan	202-203
	Super T-Series Heavy Duty Wall Fans	204-205
	Standard Range Overview	206-207
	Standard Range Window Fan	208-209
	Standard Range Roof Fan	210-211
	Standard Range Wall Fan	212-213
	Standard Range Panel fan	214-215

ACM 100-200

Features & Benefits

- Designed and manufactured in UK
- Three speed motor
- Timer versions available
- Removable motor core assembly
- Rotating motor chassis assembly
- IP44 rated
- Aesthetically pleasing with wipe clean polymer casing
- Sound data from independent testing
- Running speed selected on installation



Ducted Ventilation

Vent Axia has designed a complete range of energy efficient Mixed Flow In-Line fans that are now quieter, offer two and half times the pressure of conventional axial fans and are dimensionally more compact making them ideal for many ducted applications.

The ACM Mixed Flow In-Line fan can operate in both horizontal and vertical positions.

Motor

All motors have three speeds selectable on installation and fitted with Standard Thermal Overload Protection (S.T.O.P.). Designed for ambient temperatures up to +50°C. All sizes with capacitor run motors. All sizes are Class II appliances. Supply voltage 220-240V/1/50Hz.

Installation

These units have a separate footplate for simple location mounting and detachable spigots for simple connection to ducting. The motor body chassis rotates to provide connection in acute spaces. Cleaning the product has also become simple as all parts can be removed without removing the ducting.

Controller

For optimum variable speed performance use a Vent-Axia 1.5 Amp electronic controller. Surface mounted providing variable speed control with an On/Off/sensor slider with indication light. There is an adjustable minimum speed setting. The controller has electrical connections for use with suitable external sensors. Cannot be used with timer models.

1.5 Amp Controller (Suitable for 100mm - 200mm models) Dimensions: 86 x 156 x 53mm (H x W x D).

Stock Ref
W300310

For flush fitting a metal wall box accessory is available.

Stock Ref
400144

Hole for wall box: 80 x 150 x 150mm (H x W x D).

Models

Model	Stock Ref
ACM100	17104010
ACM100T	17104020
ACM125	17105010
ACM125T	17105020
ACM150	17106010
ACM150T	17106020
ACM200	17108010
ACM200T	17108020

Dimensions (mm)

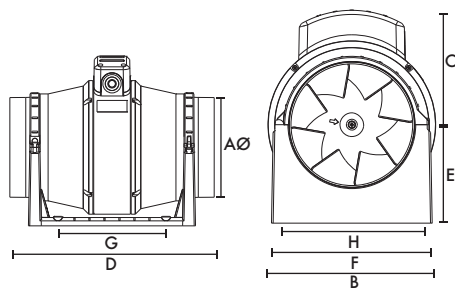

Size	100	125	150	200
AØ	97	122	147	199.5
B	178	178	200	223
C	124	124	138	146
D	298	259	350	300
E	96	96	118	130
F	168	168	192	195
G (fixing hole)	120	120	162	100
H (fixing hole)	153.5	153.5	178	180

Performance Guide

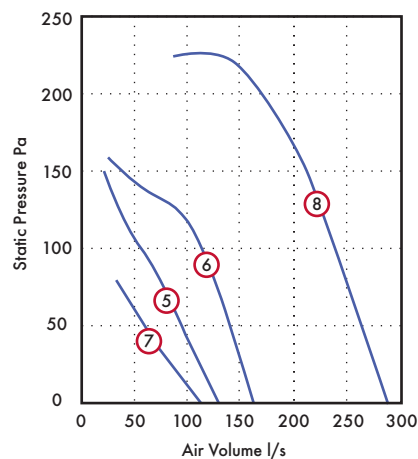
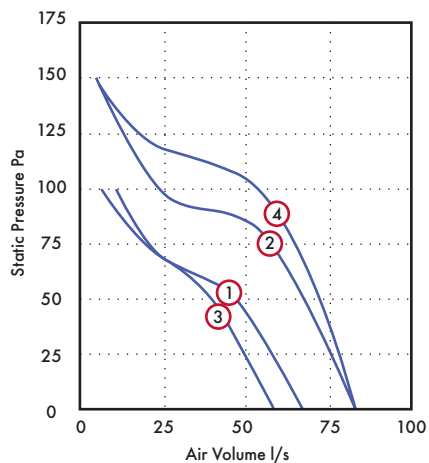

Size	Curve	Speed*	Nominal r.p.m	l/s @ 0Pa	Watts	Amps	dB(A) at 3m
100	1	Low	1580	67	21	0.09	16
	2	High	2200	83	23	0.1	22
125	3	Low	1450	64	23	0.1	17
	4	High	2320	91	30	0.12	24
150	5	Low	1645	129	40	0.17	29
	6	High	2370	163	48	0.21	36
200	7	Low	1845	113	108	0.48	26
	8	High	2300	288	110	0.55	41

*Medium speed is not shown.

ACM 250-315

Features & Benefits

- Available in two sizes
- Simple Installation
- Supplied complete for installation
- Optimise fan performance by using an approved Vent Axia controller
- Diagonal impeller with stator
- Galvanized metal housing
- Integrated thermal switch
- Includes a mounting bracket
- Designed to meet IP54



Ducted Ventilation

Vent Axia has designed a complete range of energy efficient Mixed Flow In-Line fans for use with rigid and flexible ducting.

In-line Mixed Flow fans offer two and half times the pressure of conventional axial fans and are dimensionally more compact making them ideal for many ducted applications.

The ACM Mixed Flow In-Line fan can operate in both horizontal and vertical positions and can be mounted to meet its optimum performance.

Motor

All motors are fitted with Standard Thermal Overload Protection (S.T.O.P.). Designed for ambient temperatures up to +50°C. All sizes with capacitor run motors. ACM 250 and 315 are Class I appliances. Supply voltage 220-240V/1/50Hz.

Models

Model	Stock Ref
ACM250	17110010
ACM315	17112010

ACM 250 Controller

For optimum performance use a Vent-Axia electronic controller. Surface mounted providing variable speed control with an On/Off/sensor slider with indication light. There is an adjustable minimum speed setting. The controller is radio suppressed to BS EN 55014 and electrical connections for use with suitable external sensors are provided.

1.5 Amp Controller – Suitable for 250mm model Dimensions: 86 x 156 x 53mm (H x W x D).

Model	Stock Ref
1.5A Electronic Controller	W300310

ACM315 Controller

Used in conjunction with speed controllable fans to provide 5 stepped speed without electronic motor 'hum'. Several fans can be connected to one transformer provided their combined load does not exceed the controller rating.

Single phase: 3.0amp. Rotary switch giving On/Off and five speeds.

Output voltages at 240V/1PH/50Hz 0, 90, 115, 140, 175, 240 volts.

Neon indicator. Enclosures are protected to IP54.

Dimensions: 135 x 170 x 117mm (H x W x D).

Model	Stock Ref
3A Transformer Controller	10314103

Dimensions (mm)

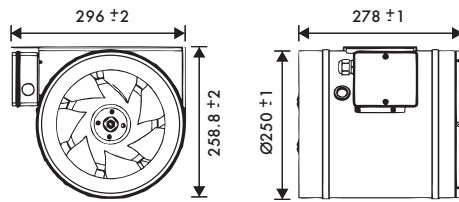

ACM250

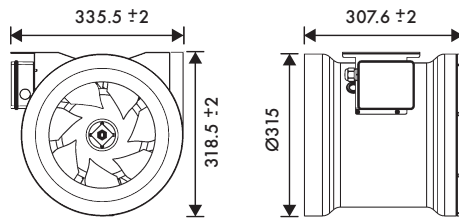

ACM315

Performance Guide

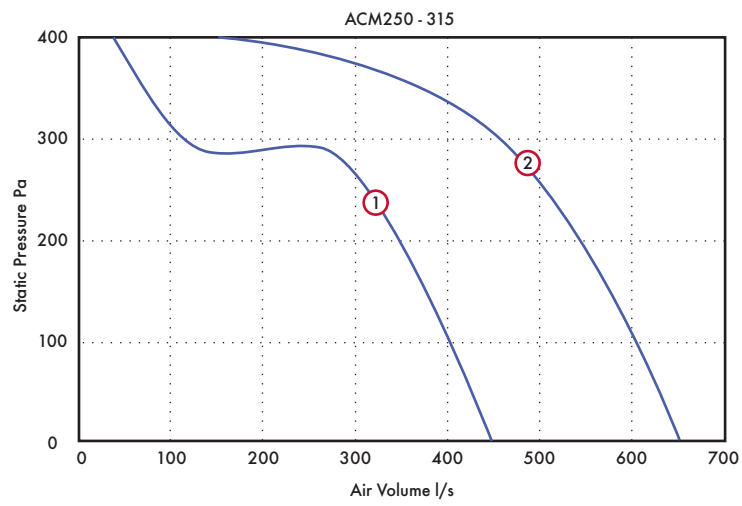

Size	Curve	Nominal r.p.m	l/s @ 0Pa	Watts	Amps	dB(A) at 3m
250	1	H 2720	450	145	0.8	52
315	2	H 2840	653	270	1.2	56

Powerflow

Features & Benefits

- Tough plastic in-line range in seven models
- 50-80mm long ribbed spigots
- Flame retardant casing
- All models speed controllable
- Fitted with Standard Thermal Overload Protection (S.T.O.P.)
- For the best performance from your fan, use a Vent-Axia controller
- IP44 Rated



Ducted Ventilation

Powerflow models provide a compact yet versatile range designed with the installer in mind, combining the acoustic benefits of a tough plastic casing with the pressure characteristics of a centrifugal fan.

A range of seven models from 100 to 315mm dia. duct sizes. The 315mm dia. model has been specifically developed for use with rigid ductwork. Air volumes from 59l/s to 340l/s in free air and capable of pressure development up to 500 Pa.

Powerflow has 50-80mm long inlet and discharge spigots allowing easy installation and fixing. The adjustable mounting foot allows the terminal box to be rotated to any angle and allows plenty of space and adjustment for screw fixing. The robust fire retardant polymeric casing combined with internal guide vanes ensures optimum airflow management through the unit.

Electrical

Motors are 220-240V single phase 50Hz. Capacitor start and run. The terminal box is integral with the case moulding. All motors are fitted with Standard Thermal Overload Protection (S.T.O.P.).

Motor/Impeller

All models are fitted with an external rotor motor and backward curved impeller assembly for long life and reliability.

All sizes are IP44 according to BS EN 60529. Ball bearings are greased for life and designed to run at any angle. Insulation is Class 'B' (from -30 °C to +40 °C). Manufacture is controlled to BS EN ISO 9001.

Models

2 Pole In-Line Duct Fan - Single Phase.

Stock Ref

ACP10012

ACP12512

ACP15012

ACP16012

ACP20012

ACP25012

ACP31512

2.5A Electronic Controller

On/Off indication light. Infinitely variable speed control. Adjustable minimum speed setting and optional sensor mode. The controller is radio-suppressed to BS800 and rated at 2.5 amps.

Model

Stock Ref

2.5A Electronic Controller **W10303102M**

Dimensions (mm)

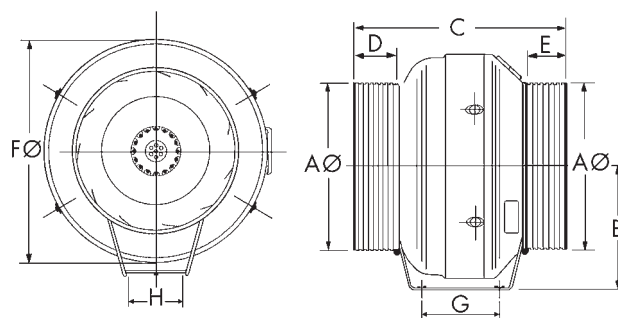

Dia	AØ	B	C	D	E	FØ	G	H	Weight
100	100	146	287	52	52	254	110	270*	2.2
125	125	146	287	60	60	254	110	270*	2.2
150	149	175	287	52	52	301	110	270*	3.1
160	160	175	287	52	52	301	110	270*	3.1
200	200	193	290	47	47	344	92	130	4.3
250	250	218	312	65	65	367	92	130	4.6
315	315	250	366	76	76	405	92	130	5.9

*Sizes 100, 125, 150 & 160 have a flat mounting foot

Performance Guide

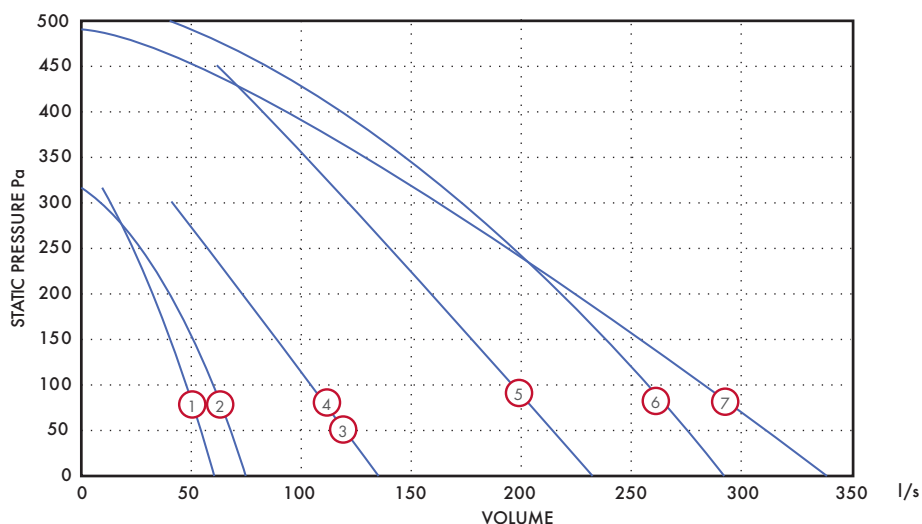

Dia.	Curve Ref.	Nominal r.p.m	l/s @ Pa											Watts	S.C. amps	F.L.C. amps	dB(A) at 3m
			0	25	50	100	150	200	250	300	350	400					
100	1	2740	59	56	52	46	39	31	21					83	0.85	0.34	35
125	2	2410	78	73	69	60	50	39	27					86	0.85	0.34	35
150	3	2520	137	130	122	106	89	73	57	39				100	1.10	0.43	45
160	4	2520	137	130	122	106	89	73	57	39				100	1.10	0.43	45
200	5	2620	234	224	214	194	177	159	138	119	100	82	150	1.52	0.68	47	
250	6	2720	290	283	270	250	234	216	197	177	156	124	185	1.60	0.77	48	
315	7	2720	339	329	313	274	244	218	191	161	131	98	182	1.57	0.75	51	

Acoustic Sound Power Level

Stock Ref.		63	125	250	500	1K	2K	4K	8K	dB(A) @3m
ACP10012	INLET	81	84	75	68	61	52	46	40	51
ACP10012	OUTLET	82	84	77	68	61	52	49	43	52
ACP10012	BREAKOUT	52	48	57	53	53	48	40	38	35
ACP12512	INLET	80	79	76	70	61	57	51	45	51
ACP12512	OUTLET	82	80	76	71	61	54	51	43	52
ACP12512	BREAKOUT	52	48	57	53	53	48	40	38	35
ACP15012	INLET	79	84	84	76	69	65	61	52	59
ACP15012	OUTLET	78	84	83	74	69	65	60	50	58
ACP15012	BREAKOUT	59	62	66	62	62	58	51	43	45
ACP16012	INLET	81	81	79	76	66	61	58	49	55
ACP16012	OUTLET	80	82	81	73	67	62	57	49	54
ACP16012	BREAKOUT	59	62	66	62	62	58	51	43	45
ACP20012	INLET	80	79	74	76	67	65	66	60	57
ACP20012	OUTLET	79	79	74	71	69	69	65	59	55
ACP20012	BREAKOUT	54	70	67	66	62	59	53	43	47
ACP25012	INLET	84	80	74	74	69	69	67	63	57
ACP25012	OUTLET	75	79	73	72	72	73	68	64	59
ACP25012	BREAKOUT	60	71	70	66	65	62	55	44	48
ACP31512	INLET	84	80	74	74	69	69	67	63	56
ACP31512	OUTLET	75	79	73	72	72	73	68	64	59
ACP31512	BREAKOUT	72	71	73	71	66	63	55	45	51

Lo-Carbon T-Series Range Overview

Features & Benefits

- Wall, Window, Roof and panel mounting versions available
- Low Energy DC Motor
- Wired or Wireless control options
- Up to 70% energy saving
- Modular design, available as a complete unit or as a separate fitting kit and fan core for refurbishment.



ErP Regulations

The introduction of the ErP regulations gave us the opportunity to review our product ranges and has enabled us to improve the way we stock and sell them. You can still buy the market leading T-Series in the same way you always have, as a complete product, however we have taken the opportunity to add a more flexible option if you need it. We have introduced a modular option for refurbishment situations where you may not want to replace the whole product.

For new build projects and complete building refits the market leading T-Series is unchanged and available as a complete unit generally supplied in one carton.

For refurbishment markets, supplying it as separate core and specific fitting kit gives more flexibility in both stocking and installing the product. This also gives the lowest overall cost to refurbish your fan system without changing wiring or controls, furthermore it also supports our Lo-Carbon drive to reduce waste and landfill.

Available as either Wired or Wireless control variants with controllers available, the Lo-Carbon T-series range offers the most flexible, efficient and controllable range of commercial fan systems.

Complete Product option

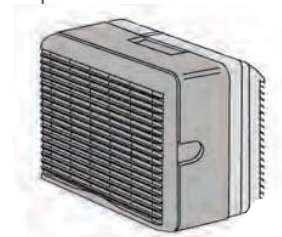

Complete product

Modular option

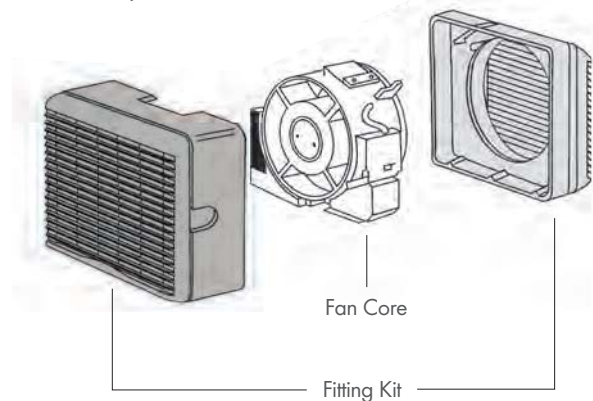

Lo-Carbon T-Series Complete Fan



Controller Type*	Size	Window	Wall	Roof	Panel
		Stock Ref	Stock Ref	Stock Ref	Stock Ref
Wired	9"	456165	456166	456168	456167
Wired	12"	456173	456174	456176	456175
Wireless	9"	456169	456170	456172	456171
Wireless	12"	456177	456178	456180	456179

* Wired or Wireless refers to the controller type that can be utilised with the particular model.

Lo-Carbon T-Series Modular Option



Fitting Kit Options (excludes Fan Core)

Controller Type*	Size	Fan Core	Window	Wall	Roof	Panel
		Stock Ref	Stock Ref	Stock Ref	Stock Ref	Stock Ref
Wired	9"	472039	472047	472043	472055	472051
Wired	12"	472040	472048	472044	472056	472052
Wireless	9"	472041	472049	472045	472057	472053
Wireless	12"	472042	472050	472046	472058	472054

* Wired or Wireless refers to the controller type that can be utilised with the particular model.

Lo-Carbon T-Series Window Fan

Features & Benefits

- Reduces your carbon footprint
- Extract/intake model in 2 sizes: 9" and 12"
- Long life Lo-Carbon motor lasts twice as long as conventional motors
- Up to 70% energy saving
- Wired or Wireless fan models available
- Easy fit connector Top Socket, standard on all models



UK's No. 1 Commercial Fan

The Lo-Carbon T-Series Fan range utilises a low energy DC motor, developed to improve performance, lower running costs and maintain T-Series' rugged reliability.

Window Fan

The fitting kit is designed for installation through single or double glazing and material up to 32mm thick. Greater thicknesses can be accommodated using extended fixing rod sets. Alternatively, the Lo-Carbon T-Series range can be used in conjunction with Vent-Axia ventilation accessories in flexible and rigid ducting systems to suit individual requirements. It can also be mounted in a fixing plate on walls or above ceilings.

Instantaneous Shutter

With energy saving in mind, units are supplied complete with an integral instantaneous automatic louvre shutter concealed behind the interior grille. It operates on both extract and intake and at any angle of mounting.

The shutter is electronically controlled by an actuator with a damped action giving quiet operation during instant opening and closing. The interlocking edges of the shutter blades provide maximum back draught protection. When the fan is used with the Lo-Carbon T-Series controller, the shutter can be set open with the fan motor switched Off to provide natural ventilation without the security risk of an open window.

Top Socket

A connector Top Socket is standard on all T-Series fans. Allowing fast and trouble-free mains connection.

Models

Complete Fan

Model	Stock Ref
9" Wired	456165
12" Wired	456173
9" Wireless	456169
12" Wireless	456177

Fan Core (excludes Window Kit)

Model	Stock Ref
9" Wired	472039
12" Wired	472040
9" Wireless	472041
12" Wireless	472042

Window Kit (excludes Fan Core)

Model	Stock Ref
9" Wired	472047
12" Wired	472048
9" Wireless	472049
12" Wireless	472050

Accessory

Extended Fixing Rod set

Size	Stock Ref
9"	568104
12"	568106

Controllers



Models	Stock Ref
Wireless	455874
Wired	455873

Dimensions (mm)

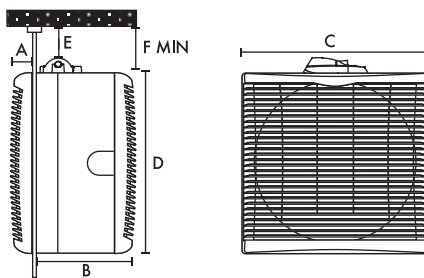

Size Dim.	9 in	12 in
A	39	41
B	150	177
C	304	381
D	302	378
E	19	19
F	54	54
Fixing hole \varnothing	260	337
Weight kg*	5.35	7.7

*Complete product. Controller (W x H x D) 97 x 99 x 32

Performance Guide

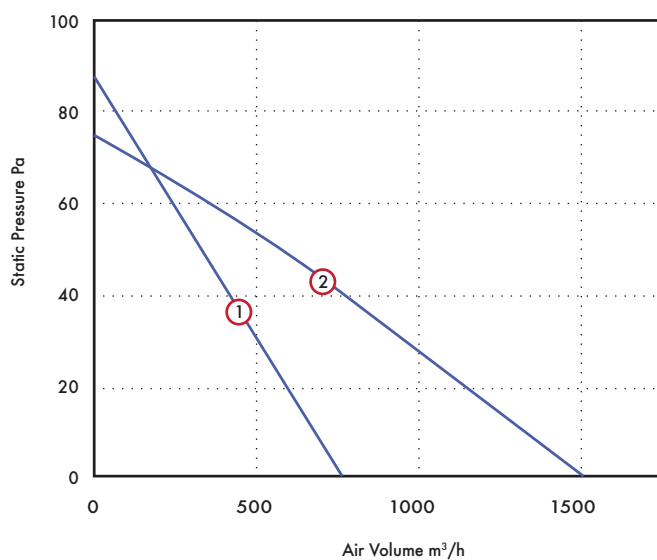

Model	Curve	Extract performance m³/h (l/s)			Watts (high)	Sound dB(A) (med) @ 3m	Amps @ 240V
		low	medium	high			
Lo-Carbon 9" Window - Wireless/Wired	①	332 (90)	571 (160)	761 (210)	30.8	40	0.35
Lo-Carbon 12" Window - Wireless/Wired	②	660 (185)	1295 (360)	1550 (430)	68.6	46	0.73

Lo-Carbon T-Series Wall Fan

Features & Benefits

- Long life Lo-Carbon motor lasts twice as long as conventional motors
- Reduces your carbon footprint
- Extract/intake model in 2 sizes: 9" and 12"
- Up to 70% energy saving
- Wired or Wireless fan models available
- Easy fit connector Top Socket, standard on all models



UK's No. 1 Commercial Fan

The Lo-Carbon T-Series Fan range utilises a low energy DC motor, developed to improve performance, lower running costs and maintain T-Series' rugged reliability.

Wall Fan

Lo-Carbon T-Series wall models are designed to fit directly into double brick, solid and cavity walls. The two part telescopic liner accommodates wall thicknesses from 240 to 315mm. For thicker walls additional liner sections are available. Lo-Carbon T-Series wall models are provided with internal and external wall frames which fit flush with both faces of the wall.

Instantaneous Shutter

Lo-Carbon T-Series models are supplied complete with an integral instantaneous automatic louvre shutter which will operate on both intake and extract and at any angle of mounting.

When the fan is used with a Lo-Carbon T-Series controller, the shutter can be set open with the fan motor switched Off to provide natural ventilation without the security risk of an open window.

Electrical

Motor purpose-designed. Suitable for running at any angle. Quiet running. Suitable for operation in ambient temperatures from -40°C to +50°C.

Fitted with self resetting Standard Thermal Overload Protection (S.T.O.P.).

Supply voltage 220-240V/1/50Hz.

Top Socket

A connector Top Socket is standard on all T-Series fans. Allowing fast and trouble-free mains connection.

Models

Complete Fan

Size	Stock Ref
9" Wired	456166
12" Wired	456174
9" Wireless	456170
12" Wireless	456178

Fan Core (excludes Wall Kit)

Size	Stock Ref
9" Wired	472039
12" Wired	472040
9" Wireless	472041
12" Wireless	472042

Wall Kit (excludes Fan Core)

Size	Stock Ref
9" Wired	472043
12" Wired	472044
9" Wireless	472045
12" Wireless	472046

Accessory

Additional Wall Liner Section

Size	Stock Ref
9"	460096
12"	460086

Controllers



Models	Stock Ref
Wireless	455874
Wired	455873

Dimensions (mm)

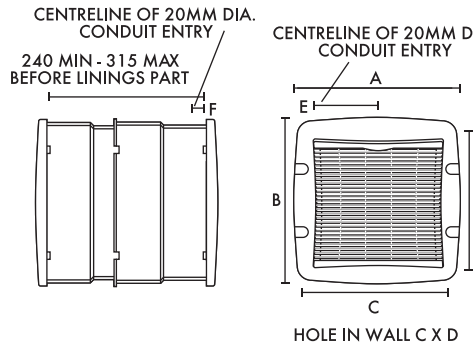

Size Dim.	9 in	12 in
A	391	470
B	388	467
C	365	442
D	375	450
E	143	182
F	25	25
Weight kg*	7.77	10.86

*Complete product. Controller (W x H x D) 97 x 99 x 32

Performance Guide

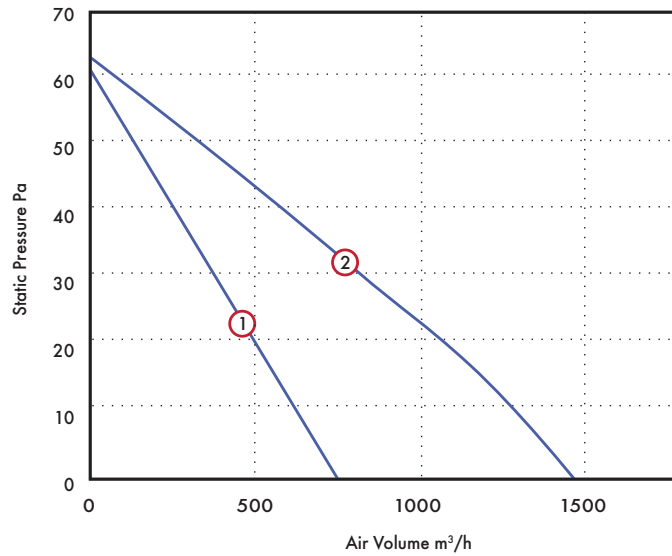

Model	Curve	Extract performance m³/h (l/s)			Watts (high)	Sound dB(A) (med) @ 3m	Amps @ 240V
		low	medium	high			
Lo-Carbon 9" Wall - Wireless/Wired	1	326 (90)	562 (160)	732 (210)	27	39	0.31
Lo-Carbon 12" Wall - Wireless/Wired	2	660 (185)	1355 (360)	1650 (430)	68	48	0.70

Lo-Carbon T-Series Roof Fan

Features & Benefits

- Reduces your carbon footprint
- Extract / intake model in 2 sizes: 9" and 12"
- Long life Lo-Carbon motor lasts twice as long as other conventional motors
- Up to 70% energy saving
- Wired or Wireless fan models available
- Easy fit connector Top Socket, standard on all models



UK's No. 1 Commercial Fan

The Lo-Carbon T-Series Fan range utilises a low energy DC motor, developed to improve performance, lower running costs and maintain T-Series' rugged reliability.

Roof Fitting Kit

Designing ventilation systems with the unit mounted in a skylight or a flat roof is easy. With a low profile cowl, the Lo-Carbon T-Series Roof model is suitable for installation in horizontal, angled (max pitch 30deg) and vertical glass and for fixing plates in roofs. For vertical windows or walls in exposed areas and single and double glazing including most types of glass up to 32mm thick. Greater thicknesses can be accommodated using extended fixing rod sets. Both sizes of Vent-Axia roof plate assemblies can be fitted easily into flat roofs.

Instantaneous Shutter

With energy saving in mind, Lo-Carbon T-Series models are supplied complete with an integral, instantaneous, automatic louvre shutter concealed behind the interior grille.

It will operate on both intake and extract and at any angle of mounting. The shutter is electronically controlled by an actuator with a damped action giving quiet operation during instant opening and closing.

When the fan is used with a Lo-Carbon T-Series controller, the shutter can be set open with the fan motor switched off to provide natural ventilation without the security risk of an open window.

Top Socket

A connector Top Socket is standard on all T-Series fans. Allowing fast and trouble-free mains connection.

Electrical

Motor purpose-designed. Suitable for running at any angle. Quiet

running, enclosed. Suitable for operation in ambient temperatures from -40°C to +50°C.

Fitted with self resetting Standard Thermal Overload Protection (S.T.O.P.).

Supply voltage 220-240V/1/50Hz.

Models

Complete Fan

Model	Stock Ref
9" Wired	456168
12" Wired	456176
9" Wireless	456172
12" Wireless	456180

Fan Core (excludes Roof Kit)

Size	Stock Ref
9" Wired	472039
12" Wired	472040
9" Wireless	472041
12" Wireless	472042

Roof Kit (excludes Fan Core)

Size	Stock Ref
9" Wired	472055
12" Wired	472056
9" Wireless	472057
12" Wireless	472058

Controllers



Models	Stock Ref
Wireless	455874
Wired	455873

Dimensions (mm)

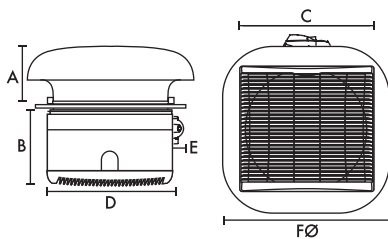

Size Dim.	9 in	12 in
A	136	171
B	150	177
C	304	381
D	302	378
E	54	54
FØ	400	500
Fixing Hole	260	337
Weight kg*	6.22	9.28

*Complete product. Controller (W x H x D) 97 x 99 x 32

Performance Graph

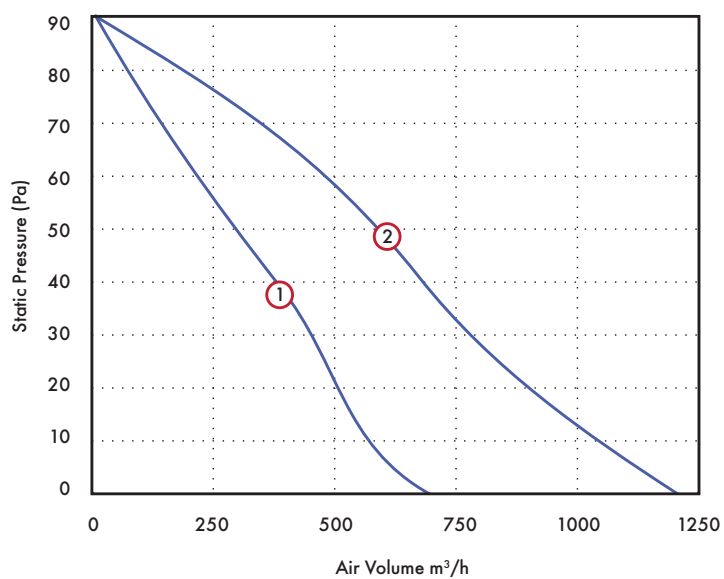

Model	Curve	Extract performance m³/h (l/s)			Watts (high)	Sound dB(A) (med) @ 3m	Amps @ 240V
		low	medium	high			
Lo-Carbon 9" Roof - Wireless/Wired	①	313 (85)	562 (155)	693 (190)	27	40	0.34
Lo-Carbon 12" Roof - Wireless/Wired	②	518 (143)	1017 (282)	1194 (330)	67	48	0.69

Lo-Carbon T-Series Panel Fan

Features & Benefits

- Reduces your carbon footprint
- Extract / intake model in 2 sizes: 9" and 12"
- Long life Lo-Carbon motor last twice as long as other conventional motors
- Up to 70% energy saving
- Wired or Wireless fan models available
- Easy fit connector Top Socket, standard on all models



UK's No. 1 Commercial Fan

The Lo-Carbon T-Series Fan range utilises a low energy DC motor, developed to improve performance, lower running costs and maintain T-Series' rugged reliability.

Panel Fitting Kit

Lo-Carbon T-Series panel/ceiling models are suitable for mounting at any angle in internal partitions, ceilings, ducts and, with louvre grilles, through external walls. When installed only the louvre grille is visible.

Instantaneous Shutter

With energy saving in mind, Lo-Carbon T-Series models are supplied complete with an integral instantaneous automatic louvre shutter concealed behind the interior grille. With a Lo-Carbon T-Series Controller the fan will operate on both extract and intake, suitable for any angle of mounting. When the fan is used with a Lo-Carbon T-Series controller, the shutter can be set open with the fan motor switched off to provide natural ventilation without the security risk of an open window.

Wireless Control

Every Lo-Carbon T-Series Wireless FM Controller uses unique digital signals to ensure trouble free operation. The controller will transmit through walls and floors allowing complete flexibility of design to control fans up to 30m away.

Top Socket

A connector Top Socket is standard on all T-Series fans. Allowing fast and trouble-free mains connection.

Electrical

Suitable for operation in ambient temperatures from -40°C to +50°C.

Fitted with self resetting Standard Thermal Overload Protection (S.T.O.P.).

Supply voltage: 220-240V/1/50Hz.

Easy Cleaning

Integrated component design allows all parts to be dismantled for cleaning without the use of specialist tools.

Models

Complete Fan

Size	Stock Ref
9" Wired	456167
12" Wired	456175
9" Wireless	456171
12" Wireless	456179

Fan Core (excludes wired Panel Kit)

Size	Stock Ref
9" Wired	472039
12" Wired	472040
9" Wireless	472041
12" Wireless	472042

Panel Kit (excludes Fan Core)

Size	Stock Ref
9" Wired	472051
12" Wired	472052
9" Wireless	472053
12" Wireless	472054

Controllers



Models	Stock Ref
Wireless	455874
Wired	455873

Dimensions (mm)

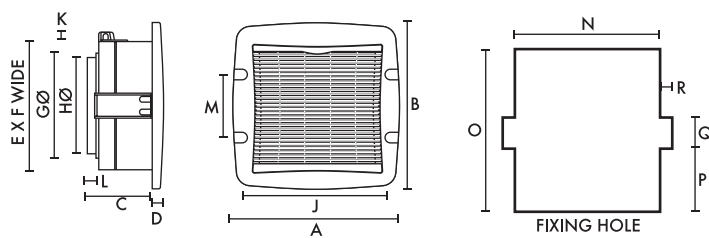

Size	9 in	12 in	Size	9 in	12 in
A	391	470	J	345	422
B	388	467	K	19	19
C	129	152	L	22	22
D	39	41	M	180	180
E	302	378	N	309	386
F	304	381	O	326	402
GØ	255	334	P	126	164
HØ	247	325	Q	55	55

Weight kg*: 9mm - 5.13, 12mm - 7.44

*Complete product. Controller (W x H x D) 97 x 99 x 32

Performance Guide

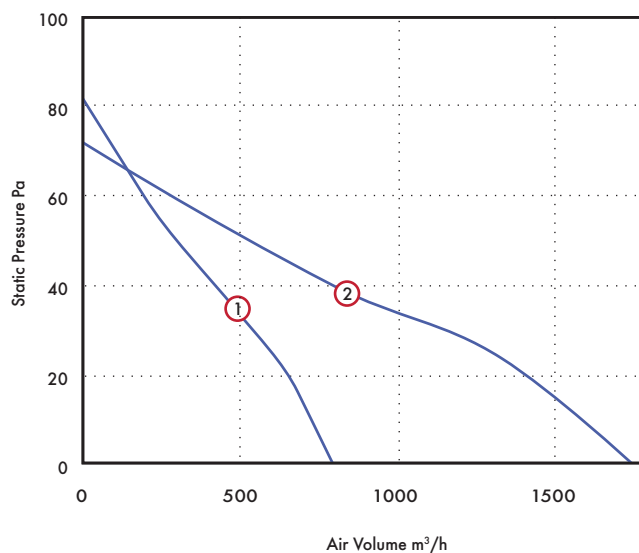

Model	Curve	Extract performance m³/h (l/s)			Watts (high)	Sound dB(A) (med) @ 3m	Amps @ 240V
		low	medium	high			
Lo-Carbon 9" Panel - Wireless/Wired	①	357 (100)	601 (166)	799 (221)	30	41	0.33
Lo-Carbon 12" Panel - Wireless/Wired	②	737 (205)	1487 (413)	1761 (490)	67	48	0.70

Traditional T-Series Range Overview

Features & Benefits

- Available as wall, window, panel, roof, inline or Darkroom models
- Available as a complete unit or modular fan core and fitting kit for refurbishments
- Flexible installation design
- Simple installation



ErP Regulations

The introduction of the ErP regulations gave us the opportunity to review our product ranges and has enabled us to improve the way we stock and sell them. You can still buy the market leading T-Series in the same way you always have, as a complete product, however we have taken the opportunity to add a more flexible option if you need it. We have introduced a modular option for refurbishment situations where you may not want to replace the whole product.

For new build projects and complete building refits the market leading T-Series is unchanged and available as a complete unit generally supplied in one carton.

For refurbishment markets, supplying as separate core and specific fitting kit gives more flexibility in both stocking and installing the product. This also gives the lowest overall cost to refurbish your fan system without changing wiring or controls, furthermore it also supports our Lo-Carbon drive to reduce waste and landfill.

Complete product option

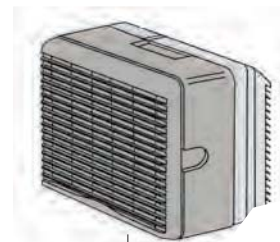

Complete product

Modular option

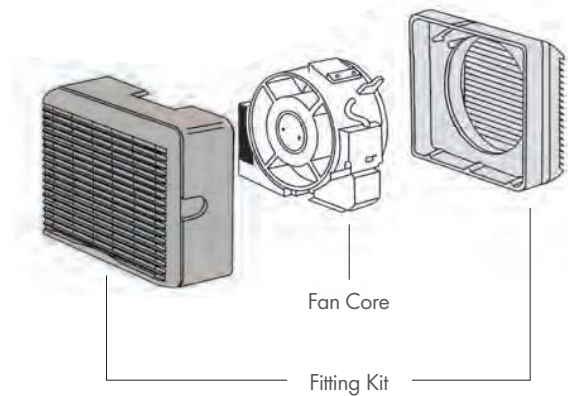

Traditional T-Series Complete Fan



	Window	Wall	Roof	Panel	Darkroom	In-line
Size	Stock Ref	Stock Ref	Stock Ref	Stock Ref	Stock Ref	Stock Ref
6"	W161110	W161510	W161210	W161610	W161240	W161710
7"	W162110	W162510	W162210	W162610	W162240	N/A
9"	W163110	W163510	W163210	W163610	W163240	W163710
12"	W164110	W164510	W164210	W164610	W164240	W164710

Traditional T-Series Modular Option



Fitting Kit Options (excludes Fan Core)

	Fan Core	Window	Wall	Roof	Panel	Darkroom	In-line
Size	Stock Ref	Stock Ref	Stock Ref	Stock Ref	Stock Ref	Stock Ref	Stock Ref
6"	472012	472020	472016	472028	472024	472032	472036
7"	472013	472021	472017	472029	472025	472033	N/A
9"	472014	472022	472018	472030	472026	472034	472037
12"	472015	472023	472019	472031	472027	472035	472038

Traditional T-Series Window Fan

Features & Benefits

- Extract/intake fans in 4 sizes: 6", 7", 9" and 12"
- Patented electronic shutter system ensures quiet trouble free operation
- To obtain the best from your fan, use the Ecotronic controller
- Shutter open/fan off mode
- Low sound levels
- Easy fit connector Top Socket, standard on all models
- Designed for single or double glazing up to 32mm thick



UK's No. 1 Commercial Fan

The T-Series fan range is fitted with a Vent-Axia M-Tech motor, developed to improve performance, lower running costs and maintain the T-Series' rugged reliability. A patented speed control pack is simply plugged in one of 3 positions to provide low, medium or boost speed matching the fan performance to the requirements of the installation.

Instantaneous Shutter

With energy saving in mind T-Series Fitting Kits are supplied complete with an integral instantaneous automatic louvre shutter concealed behind the interior grille. It operates on both extract and intake and at any angle of mounting.

When the fan is used with a T-Series or Ecotronic controller, the shutter can be set open with the fan motor switched off to provide natural ventilation without the security risk of an open window.

Top Socket

A connector Top Socket is standard on all T-Series fans allowing fast and trouble-free mains connection.

Easy Cleaning

Integrated component design allows all parts to be dismantled for cleaning without the use of specialist tools.

Electrical

Motor purpose-designed. Suitable for running at any angle. Quiet running. Suitable for operation in ambient temperatures from -40°C to +50°C.

Fitted with Standard Thermal Overload Protection (S.T.O.P.).

Supply voltage 220-240V/1/50Hz.

Window Kit

Designed for use in single or double glazing, most types of glass and materials up to 32mm thick. Greater thicknesses can be accommodated using Extended Fixing Rod Sets. Can also be mounted in a fixing plate or wall, in ducts or above ceilings.

Models

Complete Fan

Model	Stock Ref
TX6WW	W161110
TX7WW	W162110
TX9WW	W163110
TX12WW	W164110

Fan Core (excludes Fitting Kit)

Size	Stock Ref
TX6	472012
TX7	472013
TX9	472014
TX12	472015

Window Kits (excludes Fan Core)

Size	Stock Ref
TX6	472020
TX7	472021
TX9	472022
TX12	472023

Accessories

Extended Fitting Rod set

Size	Stock Ref
6/7/9"	568104
12"	568106

Controllers

Ecotronic Controller Surface Mounting

Stock Ref

W362320

T-Series Controller Surface Mounting

Stock Ref

W361119

Dimensions (mm)

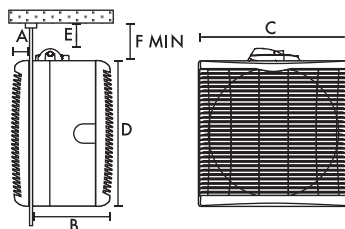

Size Dim.	6 in	7 in	9 in	12 in
A	31	31	39	41
B	130	130	150	177
C	226	265	304	381
D	220	258	302	378
E	19	19	19	19
F	54	54	54	54
Fixing hole Ø	184	222	260	337
Weight kg*	3.57	3.93	5.35	7.7

*Complete product.

Performance Guide

Model	Extract performance m ³ /h (l/s)			Watts (high)	Sound dB(A) (med) @ 3m	Amps @ 240V
	low	medium	high			
TX6 Window	245 (68)	315 (88)	360 (100)	30	41	0.24
TX7 Window	305 (85)	395 (110)	485 (135)	40	37	0.24
TX9 Window	465 (130)	685 (190)	795 (220)	85	43	0.42
TX12 Window	1095 (305)	1415 (393)	1615 (449)	105	48	0.51

Traditional T-Series Wall Fan

Features & Benefits

- Extract/intake model in 4 sizes: 6", 7", 9" and 12"
- Patented electronic shutter system ensures quiet, trouble free operation
- For the very best from your fan use the Ecotronic controller
- Easy fit connector Top Socket, standard on all models



UK's No. 1 Commercial Fan

Behind the grille of the Vent-Axia T-Series Wall model is a range of high performance extract/intake fans designed to fit through most wall thicknesses using telescopic liners supplied.

T-Series also features a unique speed control pack which enables high, medium or low speed to be preset to suit room size or required duty.

T-Series controllers may be used with this model to obtain a choice of speeds, reversible airflow direction and automatic sensor operation. The Vent-Axia Ecotronic controller gives even greater running economy with its minimum speed setting and 'E' mode.

Top Socket

A connector Top Socket is standard on all T-Series fans. Allowing fast and trouble-free mains connection.

Shutter

TX models are supplied complete with an integral instantaneous automatic louvre shutter which will operate on both intake and extract and at any angle of mounting.

When the fan is used with a T-Series or Ecotronic controller, the shutter can be set open with the fan motor switched off to provide natural ventilation without the security risk of an open window.

Electrical

Motor purpose-designed. Suitable for running at any angle. Quiet running, enclosed. Suitable for operation in ambient temperatures from -40°C to +50°C.

Fitted with Standard Thermal Overload Protection (S.T.O.P.).

Supply voltage 220-240V/1/50Hz.

Wall Kits

Designed to fit into most double brick walls using the telescopic liners, supplied. Additional liners are available to accommodate exceptionally thick brick walls.

Models

Complete Fan

Model	Stock Ref
TX6WL	W161510
TX7WL	W162510
TX9WL	W163510
TX12WL	W164510

Fan Core (excludes Fitting Kit)

Size	Stock Ref
TX6	472012
TX7	472013
TX9	472014
TX12	472015

Wall Kits (excludes Fan Core)

Size	Stock Ref
TX6	472016
TX7	472017
TX9	472018
TX12	472019

Accessories

Additional Wall Liner Section

Size	Stock Ref
TX6	460094
TX7	460095
TX9	460096
TX12	460086

Controllers

Ecotronic Controller Surface Mounting

Stock Ref

W362320

T-Series Controller Surface Mounting

Stock Ref

W361119

Dimensions (mm)

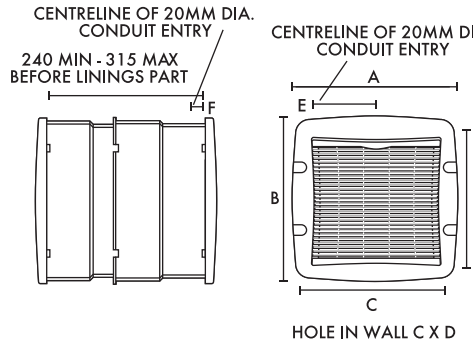

Size Dim.	6 in	7 in	9 in	12 in
A	310	352	391	470
B	303	345	388	467
C	290	330	365	442
D	290	330	375	450
E	104	124	143	182
F	25	25	25	25
Weight kg	5.54	6.13	7.77	10.86

*Complete product.

Performance Guide

Model	Extract performance m ³ /h (l/s)			Watts (high)	Sound dB(A) (med) @ 3m	Amps @ 240V
	low	medium	high			
TX6 Wall	270 (75)	350 (97)	395 (110)	40	43	0.24
TX7 Wall	335 (93)	435 (120)	530 (147)	40	39	0.24
TX9 Wall	515 (143)	755 (210)	870 (241)	85	43	0.42
TX12 Wall	1185 (329)	1530 (425)	1745 (485)	105	49	0.51

Traditional T-Series Roof Fan

Features & Benefits

- Extract/intake model in 4 sizes: 6", 7", 9" and 12"
- Patented electronic shutter system ensures quiet, trouble free operation
- For the very best from your fan use the Ecotronic controller
- T-Series controllers and sensors save energy by only switching on the units when you want them to, either manually or automatically
- Easy fit connector Top Socket, standard on all models



UK's No. 1 Commercial Fan

With a low profile cowl, the T-Series Roof model is suitable for installation in horizontal, angled (max pitch 30deg) and vertical glass and for fixing plates in roofs. For vertical windows or walls in exposed areas and single or double glazing including most types of glass up to 32mm thick. Greater thicknesses can be accommodated using extended fixing rod sets. All four sizes of Vent-Axia roof plate assemblies can be fitted easily into flat roofs.

T-Series features a unique speed control pack which enables high, medium or low speed to be preset to suit room size or required duty. When used with a T-Series TSC controller, the speed control pack is removed from the T-Series fan and fitted into the 3-pin socket in the back of the controller. The Vent-Axia Ecotronic controller gives even greater running economy with its minimum speed setting and 'E' mode. When using the Ecotronic controller the speed control pack remains in the fan.

Shutter

With energy saving in mind, T-Series Fitting Kits are supplied complete with an integral instantaneous automatic louvre shutter concealed behind the interior grille. It will operate on both intake and extract and at any angle of mounting.

When the fan is used with a T-Series or Ecotronic controller, the shutter can be set open with the fan motor switched off to provide natural ventilation without the security risk of an open window.

Electrical

Motor purpose-designed. Suitable for running at any angle. Quiet running, enclosed. Suitable for operation in ambient temperatures from -40°C to +50°C.

Fitted with Standard Thermal Overload Protection (S.T.O.P.).

Supply voltage 220-240V/1/50 Hz .

Top Socket

A connector Top Socket is standard on all T-Series fans. Allowing fast and trouble-free mains connection.

Models

Complete Fan

Model	Stock Ref
TX6RF	W161210
TX7RF	W162210
TX9RF	W163210
TX12RF	W164210

Fan Core (excludes Fitting Kit)

Size	Stock Ref
TX6	472012
TX7	472013
TX9	472014
TX12	472015

Roof Kit (excludes Fan Core)

Size	Stock Ref
TX6	472028
TX7	472029
TX9	472030
TX12	472031

Controllers

Ecotronic Controller Surface Mounting

Stock Ref
W362320

T-Series Controller Surface Mounting

Stock Ref
W361119

Dimensions (mm)

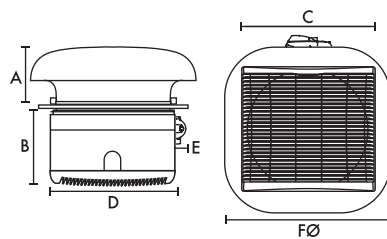

Size Dim.	6 in	7 in	9 in	12 in
A	100	136	136	171
B	130	130	150	177
C	226	265	304	381
D	220	258	302	378
E	54	54	54	54
F Ø	285	400	400	500
Fixing Hole Ø	184	222	260	337
Weight kg*	3.96	4.89	6.22	9.28

* Complete product.

Performance

Model	Extract performance m ³ /h (l/s)			Watts (high)	Sound dB(A) (med) @ 3m	Amps @ 240V
	low	medium	high			
TX6 Roof	195 (55)	250 (70)	290 (80)	30	41	0.24
TX7 Roof	305 (85)	395 (110)	485 (135)	40	37	0.24
TX9 Roof	465 (130)	685 (190)	795 (220)	85	43	0.42
TX12 Roof	1010 (280)	1305 (362)	1485 (412)	105	48	0.51

Traditional T-Series Panel/Ceiling Fan

Features & Benefits

- Extract/intake model in 4 sizes: 6", 7", 9" and 12"
- Colour: soft tone grey
- Patented electronic shutter system ensures quiet trouble-free operation
- For the very best from your fan use the Ecotronic controller
- East fit connector Top Socket, standard on all models



UK's No. 1 Commercial Fan

Vent-Axia T-Series Panel/Ceiling models are suitable for mounting at any angle in internal partitions, ceilings, ducts and, with louvre grilles, through external walls. When installed only the louvre grille is visible. The range features a unique speed control pack which enables high, medium or low speed to be preset to suit a specific room size or required duty.

T-Series controllers may be used with this model to obtain a choice of speeds, reversible airflow direction and automatic sensor operation. When used with a controller, the speed control pack is removed from the T-Series fan and fitted into the 3-pin socket in the back of the controller. The Vent-Axia Ecotronic controller gives even greater running economy with its minimum speed setting on 'E' mode and infinitely variable speed control. For this controller the speed control pack remains in the fan.

Electrical

Suitable for operation in ambient temperatures from -40°C to +50°C.

Fitted with Standard Thermal Overload Protection (S.T.O.P).

Supply voltage: 220-240V/1/50Hz.

Top Socket

A connector Top Socket is standard on all T-Series fans allowing fast and trouble-free mains connection.

Shutter

With energy saving in mind, panel/ceiling kits are supplied complete with an integral instantaneous automatic louvre shutter concealed behind the interior grille. It will operate on both intake and extract and at any angle of mounting.

When the fan is used with a T-Series or Ecotronic controller, the shutter can be set open with the fan motor switched off to provide natural ventilation without the security risk of an open window.

Models

Complete Fan

Model	Stock Ref
TX6PL	W161610
TX7PL	W162610
TX9PL	W163610
TX12PL	W164610

Fan Core (excludes Fitting Kit)

Size	Stock Ref
TX6	472012
TX7	472013
TX9	472014
TX12	472015

Panel/Ceiling Kit (excludes Fan Core)

Size	Stock Ref
TX6	472024
TX7	472025
TX9	472026
TX12	472027

Controllers

Ecotronic Controller Surface Mounting

Stock Ref
W362320

T-Series Controller Surface Mounting

Stock Ref
W361119

Dimensions (mm)

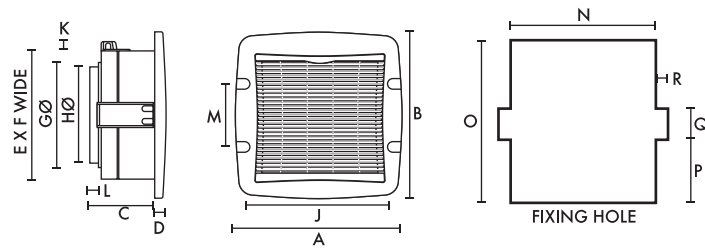

Size Dim.	6 in	7 in	9 in	12 in
A	310	352	391	470
B	303	345	388	467
C	117	117	129	152
D	32	32	39	41
E	220	258	302	378
F	226	265	304	381
GØ	180	218	255	334
HØ	171	210	247	325
J	267	306	345	422
K	19	19	19	19
L	22	22	22	22
M	180	180	180	180
N	231	270	309	386
O	244	282	326	402
P	85	104	126	164
Q	55	55	55	55
R	12	12	12	12
Weight kg*	3.50	3.82	5.13	7.44

* Complete product.

Performance Guide

Model	Extract performance m ³ /h (l/s)			Watts (high)	Sound dB(A) (med) @ 3m	Amps @ 240V
	low	medium	high			
TX6 Panel/Ceiling	295 (81)	380 (105)	435 (120)	30	41	0.24
TX7 Panel/Ceiling	365 (101)	480 (133)	585 (162)	40	37	0.24
TX9 Panel/Ceiling	565 (157)	830 (230)	960 (267)	85	43	0.42
TX12 Panel/Ceiling	1270 (353)	1640 (456)	1885 (524)	105	44	0.51

Traditional T-Series Darkroom Fan

Features & Benefits

- Extract/intake models in 4 sizes: 6", 7", 9" and 12"
- Specially designed to provide extract/intake ventilation in darkrooms, X-ray areas, etc
- Patented electronic shutter system ensures quiet, trouble free operation
- For the very best from your fan use the Ecotronic controller
- Integrated component design allows all parts to be dismantled for cleaning without the use of specialist tools
- Easy fit connector Top Socket, standard on all models



UK's No. 1 Commercial Fan

A range designed for photographic, medical, dental and veterinarian applications - used also for opticians and other specialist applications. Most darkrooms need a minimum of ten air changes per hour for comfort and efficiency. For rooms containing heat producing equipment (eg: print glazers) a higher rate of air change may be desirable.

The Darkroom fitting kit has two cowls, the interior cowl being designed to give light protection. It can be installed in windows, partitions, external walls or roofs. Extended fixing rods for fixing thicknesses up to 370mm are supplied with the unit. Provision should be made for adequate air replacement through Vent-Axia non-vision grilles.

Shutter

With energy savings in mind Darkroom models are supplied complete with an integral instantaneous automatic louvre shutter concealed behind the interior cowl. Operates on intake and extract at any angle of mounting.

When used with a T-Series or Ecotronic controller, the shutter can be set open with the fan motor switched Off to provide natural ventilation without the security risk of an open window.

Top Socket

A connector Top Socket is standard on all T-Series fans. Allowing fast and trouble-free mains connection.

Electrical

Suitable for running at any angle. Quiet running, enclosed. Fitted with Standard Thermal Overload Protection (S.T.O.P.).

Supply voltage: 220-240V/1/50Hz.

Suitable for operation in ambient temperatures from -40°C to +50°C.

Models

Complete Fan

Model	Stock Ref
TX6DR	W161240
TX7DR	W162240
TX9DR	W163240
TX12DR	W164240

Fan Core (excludes Fitting Kit)

Size	Stock Ref
TX6	472012
TX7	472013
TX9	472014
TX12	472015

Darkroom Kit (excludes Fan Core)

Size	Stock Ref
TX6	472032
TX7	472033
TX9	472034
TX12	472035

Controllers

Ecotronic Controller Surface Mounting

Stock Ref
W362320

T-Series Controller Surface Mounting

Stock Ref
W361119

Dimensions (mm)

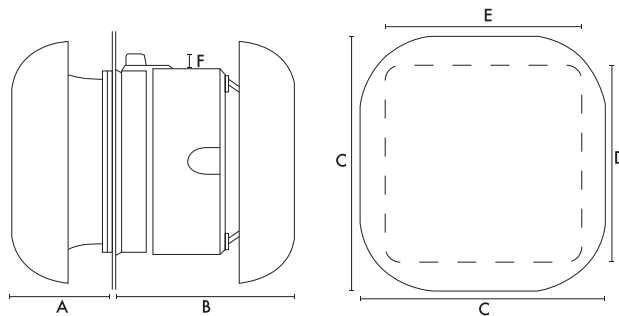

Size Dim.	6 in	7 in	9 in	12 in
A	100	136	136	171
B	196	206	229	308
C	285	400	400	500
D	220	258	302	378
E	226	265	304	381
F	19	19	19	19
Fixing Hole Ø	184	222	260	337
Weight kg*	4.13	5.33	6.60	10.05

*Complete product.

Performance Guide

Model	Extract performance m ³ /h (l/s)			Watts (high)	Sound dB(A) (med) @ 3m	Amps @ 240V
	low	medium	high			
TX6 Darkroom	200 (55)	240 (67)	265 (74)	30	43	0.24
TX7 Darkroom	330 (92)	415 (115)	530 (147)	40	42	0.24
TX9 Darkroom	455 (126)	630 (175)	725 (201)	85	45	0.42
TX12 Darkroom	870 (242)	1040 (289)	1130 (314)	100	42	0.51

Traditional T-Series In-Line Fan

Features & Benefits

- Extract/intake model in 3 sizes: 6", 9" and 12"
- Patented instantaneous electronic shutter system ensures quiet, trouble free operation
- For the best from your fan use the Ecotronic controller
- T-Series controllers and sensor save energy by only switching on the units when you want them to, either manually or automatically
- Easy fit connector Top Socket, standard on all models



UK's No. 1 Commercial Fan

No other range of high performance in-line duct fans offers a combination of 3 impeller diameters, reversibility, low sound level, speed control and built-in electric shutter. T-Series features a unique speed control pack which enables high, medium or low speed to be preset to suit room size or required duty. Designed for use with rigid or flexible ducting, T-Series In-Line models can be plate mounted or fixed through partitions and in ceiling voids.

T-Series controllers may be used with this model to obtain a choice of speeds, extract/intake airflow direction and automatic sensor operation. The Vent-Axia Ecotronic controller gives even greater running economy with its minimum speed setting and 'E' mode.

Top Socket

A connector Top Socket is standard on all T-Series fans. Allowing fast and trouble-free mains connection.

Shutter

The shutter is electronically controlled by an actuator with a damped action giving quiet operation during instant opening and closing. The interlocking edges of the shutter blades provide maximum back draught protection.

When the fan is used with a T-Series or Ecotronic controller, the shutter can be set open with the fan motor switched off to provide natural ventilation without the security risk of an open window.

Ducts

Where ducts pass through an unheated roof void, the duct should be insulated. Horizontal ducts should fall away from the fan unit. In circumstances where an excessive amount of moisture is present, a condensation trap should be installed in the exhaust duct. The fan unit should be accessible for regular maintenance.

Electrical

Suitable for operation in ambient temperatures from -40°C to +50°C.

Fitted with Standard Thermal Overload Protection (S.T.O.P.).

Supply voltage 220-240V/1/50 Hz.

Models

Complete Fan

Model	Stock Ref
TX6IL	W161710
TX9IL	W163710
TX12IL	W164710

Fan Core (excludes Fitting Kit)

Model	Stock Ref
TX6	472012
TX9	472014
TX12	472015

In-line Kit (excludes Fan Core)

Model	Stock Ref
TX6	472036
TX9	472037
TX12	472038

For use with rigid and flexible ducting. Can be plate-mounted or fixed to partitions and in ceiling voids.

Controllers

Ecotronic Controller Surface Mounting

Stock Ref
W362320

T-Series Controller Surface Mounting

Stock Ref
W361119

Dimensions (mm)

Sizes 6 & 9

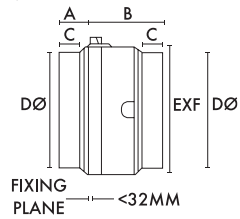

Size 12

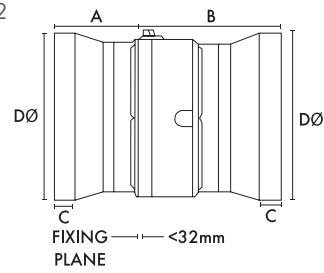

Size Dim.	6 in	9 in	12 in
A	75	71	200
B	175	183	337
C	45	41	45
DØ	175	300	400
E	220	302	378
F	226	304	381
Fixing Hole Ø	184	260	337
kg	4.5	8	11.5

Performance Guide

Model	Extract performance m ³ /h (l/s)			Watts (high)	Sound dB(A) (med) @ 3m	Amps @ 240V
	low	medium	high			
TX6 In-line	318 (88)	398 (110)	444 (123)	30	45	0.24
TX9 In-line	703 (195)	966 (268)	1050 (292)	85	47	0.42
TX12 [*] In-line	1674 (465)	2000 (556)	2230 (620)	100	51	0.51

Super T-Series

Features & Benefits

- 4 impeller diameters 355, 400, 450, 500mm
- Complete with telescopic wall sleeve and shutter, ready for installation
- IP54 motor and terminal box
- Smart internal grille and external shutter with flange trim
- Super quiet operation
- For the very best performance from your fan, use the Vent-Axia 25 Amp electronic controller



Powerful Ventilation

Vent-Axia's Super T-Series 355, 400, 450 and 500mm fans provide efficient, quiet powerful ventilation with performances up to 4940m³/h. Tough heavy duty internal grilles and external weather shutters ensure longevity, performance and peace of mind.

Construction

The axial fan at the heart of the Super T range is based on an integrated impeller and internal rotor motor design which produces a very compact unit. A specially designed bellmouth inlet and mounting plate ensures an excellent performance to sound level ratio.

Electrical

Single phase 220-240V 50Hz. Capacitor start and run. An IP54 terminal box is supplied with all models with conduit entry from the side of the wall liner. All motors are fitted with Standard Thermal Overload Protection (S.T.O.P.), which should be wired via the controller.

Models

Super T - Gravity shutter

When installed, only the room side aluminium fascia grille is visible. The outside is finished with an external gravity shutter and frame.

Model	Stock Ref
ST355-16-WL	165510
ST400-16-WL	166510
ST450-16-WL	167510
ST500-16-WL	168510

Super T TX - Electric shutter

Super T TX extract or intake models with powerful, quiet, smooth-operation electric shutters.

Model	Stock Ref
STX355	165710
STX400	166710

STX450	167710
STX500	168710

Super T Filtered Air Input

Super T ARX and AR filtered passive air replacement input unit. Consisting of a wall liner with high capacity high disposable EU4 pleated filter which fits inside the wall liner.

ARX Models

With electronically controlled integral shutter AR Models - external louvre fixed blade.

Model	Stock Ref
Units with integral shutter	
STARX355	165810
STARX450	167810

Units with louvre fixed blades

STAR355	165910
STAR450	167910

Filtered Kitchen Extract - Super T GF

Super T GF extract unit without internal grille, but with matching stainless steel filter housing and tray kit ready for assembly on site and 50mm stainless steel framed mesh grease filter with handles.

Model	Stock Ref
STGF355	165620
STGF400	166620

Accessories

Replacement Grease Filters

Super T replacement grease filters 50mm stainless steel mesh filter with handles. Supplied in packs of two.

Model	Stock Ref
355	452550
400	452551

Replacement Air Filters

High capacity EU4 pleated filter which fits inside wall liner. Supplied in packs of five.

Model	Stock Ref
355	452814
450	452815

Electronic 2.5A Controller

Provides variable motor speed control. On/Off with indication light. Infinitely variable speed slider control. Presetable minimum speed and sensor mode option: can be connected to a range of Vent-Axia sensors. Radio suppressed to BS 800. Includes electric shutter output.

Stock Ref
W10303102M

Dimensions (mm)

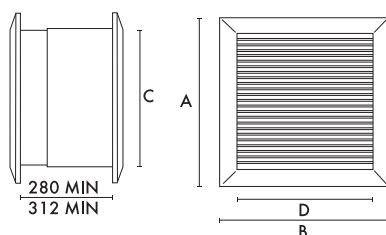

CxD SQ. HOLE THROUGH WALL

Impeller dia.	355	400	450	500
A	550	597	657	727
B	550	597	657	727
C	470	520	580	650
D	470	520	580	650
Weight kg	17	22	28	33

Performance Guide

Model	Extract Performance m ³ /h (l/s) F.I.D.	Watts	S.C. amps	F.L.C. amps	Sound dB(A) @ 3m
355-16	1735 (482)	150	1.38	0.7	40
400-16	2165 (601)	90	1.2	0.46	45
450-16	3550 (986)	130	1.4	0.46	48
500-16	4940 (1372)	360	3.6	1.6	51
355-14	2150 (597)	150	1.38	0.7	56
400-14	3500 (972)	190	1.45	0.84	59

Traditional Standard Range Overview

Features & Benefits

- Retro styled product
- Available as a fan core and fitting kit for refurbishment



ErP Regulations

The introduction of the ErP regulations has given us the opportunity to review our product ranges and has enabled us to improve the way we stock and sell them.

You can still buy the Standard Range in the same way you always have, as a complete product, however we have taken the opportunity to add a more flexible option if you need it. We have introduced a modular option for refurbishment situations where you may not want to replace the whole product. The Standard Range can also be supplied as a Fan Core or specific fitting kit, this gives you more flexibility in both stocking and installing the product. It also supports our Lo-Carbon drive to reduce waste and landfill.

There are two variants of Core assembly, the Window/Roof Core and the Panel / Wall Core.

The Window / Roof core are the circular fitting assemblies and consists of all internal components. The fitting kit consists of the externally mounted components (eg cowl or grill).

The Wall and Panel core assemblies are square and contains the wiring loom for connecting to the relevant fixing kit (if required). The Wall fitting kit consists of the external grill and the wall mounting sleeve. The panel fan has no separate fixing kit.

Modular option

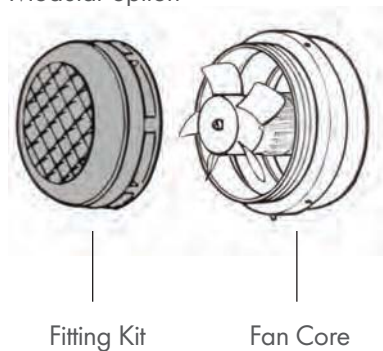

Complete product option

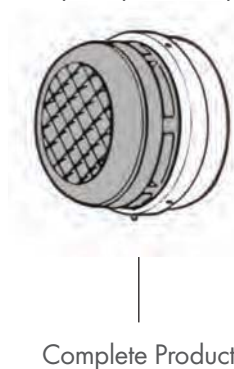

Traditional Standard Window & Roof Range



Fitting Kit Options (excludes Fan Core)

Size	Window Complete Fan	Roof Complete Fan	Window/Roof Fan Core	Fitting Kit Options (excludes Fan Core)	
	Stock Ref	Stock Ref	Stock Ref	Window Stock Ref	Roof Stock Ref
6"	131310	131410	472226	472230	472234
7"	132310	132410	472227	472231	472235
9"	133310	133410	472228	472232	472236
12"	134310	134410	472229	472233	472237

Traditional Standard Wall & Panel Range



Size	Wall Fan Complete Fan	Wall Fan Core	Wall Fitting Kit (excludes Fan Core)	Size	Panel Fan
	Stock Ref	Stock Ref	Stock Ref		Stock Ref
6"	131510	472222	472274	6"	472442
7"	132510	472223	472275	7"	472443
9"	133510	472224	472276	9"	472444
12"	134510	472225	472277	12"	472445

Traditional Standard Window Fan

Features & Benefits

- Extract / intake model in 4 sizes: 6", 7", 9" and 12"
- IPX4 Rated
- Colour: White
- Manufactured in weather-resistant polymeric materials
- For the best performance from your fan, use an Ecotronic controller
- Suitable for glass or panels up to 10mm thick



Classic Retro-Style Ventilation

This ever popular range of extract/intake fans continues to satisfy the most demanding requirements for efficient ventilation. The Vent-Axia Standard Range fitting kit unit is supplied without a shutter. The shutter is available as an accessory, which can be easily fitted within the unit.

Standard Range Window Fans and Fitting Kits are suitable for most forms of single glazing or can be wall mounted in a Vent-Axia fixing plate. Vent-Axia's patented spigot and ring method of fixing ensures easy installation and a weather proof joint. The simple integrated component design makes installation and servicing easy.

Fan Core Motor

Purpose designed enclosed motor. Suitable for running at any angle. Quiet running.

Supply voltage 220-240V/1/50 Hz. Suitable for operation in ambient temperatures from -40° to +50°C. Fitted with Standard Thermal Overload Protection (S.T.O.P.).

Shutter Type SD/R

The extract/intake shutter fits inside the Vent-Axia unit and closes against unwanted back draughts. It can be fitted at the same time as the unit or at a later date if required.

Airflow operated for extract use, cord operated lock for intake use. For all models mounted in vertical surfaces only.

Controller

The Ecotronic controller is recommended for use with this model to provide full function control of the fan plus the option of sensor mode using a selection of electro-mechanical switches to provide automatic switching of the fan.

Alternatively, single speed extract is achieved using a normal On/Off switch.

Easy Cleaning

Integrated component design allows all parts to be dismantled for cleaning without the use of specialist tools.

Protective Grilles

Where Standard Range units are installed in low positions, finger guards provide extra protection to VDE, DIN 31001.

Models

Complete Fan

Size	Stock Ref
S6WW	131310
S7WW	132310
S9WW	133310
S12WW	134310

Fan Core (excludes Window Kit)

Size	Stock Ref
6"	472226
7"	472227
9"	472228
12"	472229

Window Kit (excludes Fan Core)

Size	Stock Ref
6"	472230
7"	472231
9"	472232
12"	472233

Accessories

Shutters

Size	Stock Ref
S6SD/R	231710
S7SD/R	232710
S9SD/R	233710
S12SD/R	234710

Fan & Fitting Kit Dimensions (mm)

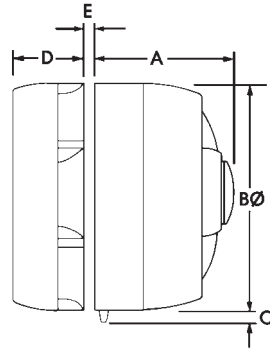

Size	6 in	7 in	9 in	12 in
A	140	147	166	201
B Ø	216	254	295	381
C	21	21	21	21
D	83	83	92	105
E (max)	10	10	10	13
Fixing hole Ø	184	222	260	337
Weight kg*	2.9	3.2	4.6	7.0

*Fan Core and Fitting Kit combined weight

Performance

Model	Extract Performance m ³ /h (l/s) F.I.D.	Watts MAX.	Sound dB(A) @ 3m	Amps @ 240V
S6WW	285 (79)	32	35	0.16
S7WW	425 (118)	34	31	0.16
S9WW	710 (197)	53	39	0.24
S12WW	1560 (433)	84	42	0.36

Traditional Standard Roof Fan

Features & Benefits

- Extract model in 4 sizes: 6", 7", 9" and 12"
- IPX4 Rated
- Colour: White
- Wide range of sensors available
- Manufactured in weather-resistant polymeric materials
- For the best performance from your fan, use an Ecotronic controller



Classic Retro-Styled Ventilation

A versatile and robust range of roof extract fans designed to satisfy the requirements of efficient ventilation in commercial and industrial applications. The simple, proven design of Standard Range makes installation and routine cleaning easy.

Featuring a low profile cowl, the unit is ready for fitting into horizontal, angled and vertical glass, fixing plates on roofs and in vertical windows or walls in exposed areas. With Vent-Axia roof plate assemblies, all four sizes can be fitted easily into flat roofs. Suitable for roof installation plus window and wall installation in exposed areas eg: coastal positions. Vent-Axia's spigot and ring method of fixing ensures easy installation and a weather proof joint. We recommend the use of sealing compound under the upper part of the unit when fitted in roofs.

Fan Core Motor

Purpose designed enclosed motor. Suitable for running at any angle. Quiet running, continuous rated motor with sealed for life ball bearings.

Suitable for operation in ambient temperatures from -40°C to +50°C. Fitted with Standard Thermal Overload Protection (S.T.O.P.).

Supply voltage 220-240V/1/50Hz.

All Standard Range roof models are designed to fit directly into horizontal and sloping windows including wired cast, up to 10mm thick.

In solid roofs, install using a roof plate assembly and, if required, and eggcrate grille in the ceiling below. A suitable sealing compound should be used between the glass/roof plate and the exterior seal.

Models

Complete Fan

Size	Stock Ref
S6RF	131410
S7RF	132410
S9RF	133410
S12RF	134410

Fan Core (excludes Roof Kit)

Size	Stock Ref
6"	472226
7"	472227
9"	472228
12"	472229

Roof Kit (excludes Fan Core)

Size	Stock Ref
6"	472234
7"	472235
9"	472236
12"	472237

Fan & Fitting Kit Dimensions (mm)

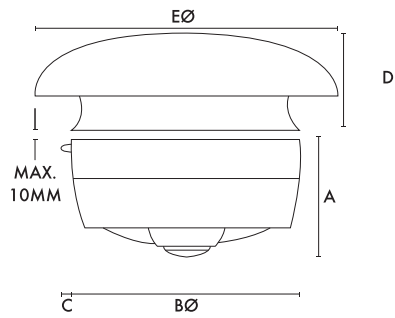

Size	6 in	7 in	9 in	12 in
A	140	147	166	201
B Ø	216	254	295	381
C	21	21	21	21
D	95	108	121	146
E Ø	267	330	394	508
Fixing hole Ø	184	222	260	337
Weight kg*	3.2	3.9	5.5	8.5

*Fan Core and Fitting Kit combined weight

Performance

Model	Extract Performance m ³ /h (l/s) F.I.D.	Watts MAX.	Sound dB(A) @ 3m	Amps @ 240V
S6RF	240 (67)	32	36	0.16
S7RF	350 (97)	34	31	0.16
S9RF	625 (174)	53	39	0.24
S12RF	1130 (314)	84	42	0.36

Traditional Standard Wall Fan

Features & Benefits

- Extract/intake models in 4 sizes: 6", 7", 9" and 12"
- IPX4 Rated
- White fascia, wall sleeve and black external weather louvre
- Optional shutter available
- Manufactured in weather-resistant polymeric materials
- For the best performance from your fan, use an Ecotronic controller



Classic Retro-Styled Ventilation

The proven Standard Range Wall Fans and Fitting Kits are designed to fit flush into most double brick walls using the rigid wall liner supplied. Provision is made within the liner for conduit entry. When installed, only the ivory fascia is visible on the internal wall face. The external weather louvre fits flush to the outside. A shutter is available as an accessory which can be easily fitted within the unit.

On new building work the installation and wiring of the wall liner can be completed prior to the final installation of the unit and controller. Fully shrouded connectors on the fascia automatically connect the wiring to the motor when fitted to the wall liner.

Fan Core Motor

The motor is purpose-designed. Suitable for running at any angle. Quiet running, enclosed, sealed for life ball bearings.

Supply voltage: 220-240V/1/50Hz.

Suitable for operation in ambient temperatures from -40°C to +50°C.

Fitted with Standard Thermal Overload Protection (S.T.O.P.).

Shutter

Type SD/R

The extract/intake shutter fits inside the Vent-Axia unit and closes against unwanted back draughts. It can be fitted at the same time as the unit or at a later date if required. Airflow operated for extract use, cord operated lock for intake use.

Controller

The Ecotronic controller is recommended for use with this model to give full function control of the fan including auto mode using an electro-mechanical sensor from Vent-Axia's sensor range. Alternatively, single speed extract is achieved using a normal On/Off switch.

Models

Complete Fan

Size	Stock Ref
S6WL	131510
S7WL	132510
S9WL	133510
S12WL	134510

Fan Core (excludes Wall Kit)

Size	Stock Ref
6"	472222
7"	472223
9"	472224
12"	472225

Wall Kit (excludes Fan Core)

Size	Stock Ref
6"	472274
7"	472275
9"	472276
12"	472277

Accessories

Shutters

Size	Stock Ref
S6SD/R	231710
S7SD/R	232710
S9SD/R	233710
S12SD/R	234710

Fitting Kit Dimensions (mm)

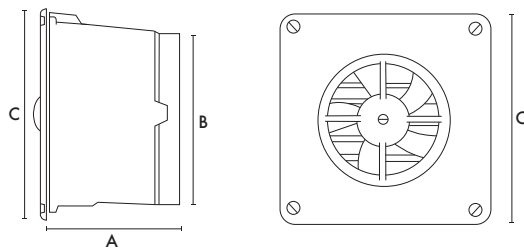

Size	6 in	7 in	9 in	12 in
A	279	279	279	279
B	203	279	279	356
C	279	362	362	448
Fixing hole Ø	235	311	311	400
Weight kg*	4.1	5.7	6.7	10.1

*Fan Core and Fitting Kit combined weight

Performance

Model	Extract Performance m ³ /h (l/s) F.I.D.	Watts MAX.	Sound dB(A) @ 3m	Amps @ 240V
S6WL	340 (94)	32	39	0.16
S7WL	544 (151)	34	35	0.16
S9WL	856 (238)	53	43	0.24
S12WL	1767 (491)	84	46	0.36

Please note that the Standard Range Panel model is not suitable for fitting within an existing Standard Range Wall fitting kit. Please use the correct Standard range Wall Core assembly.

Traditional Standard Panel Fan

Features & Benefits

- Extract / intake model in 4 sizes: 6", 7", 9" and 12"
- IPX4 Rated
- Built-in shutter available
- Colour: White Fascia
- Pre-wired lead for easy installation
- Manufactured in weather-resistant polymeric materials
- For the best performance from your fan, use a Ecotronic controller



Classic Retro-Styled Ventilation

A versatile range of extract/intake fans designed to satisfy the most demanding requirements of efficient ventilation. Available in four sizes, the Standard Range Panel Fan is supplied without a shutter for vertical installations. The shutter is available as an accessory which can be easily fitted within the unit.

Suitable for mounting at any angle, this range may be installed in internal partitions, ceilings, ducts, and (with external louvres) through external walls.

The outer spigot may be connected directly to flexible ducting and other Vent-Axia ventilation accessories to suit individual applications. When installed, only the white fascia is visible.

Shutter

Type SD/R

The vertical extract/intake shutter fits inside the Vent-Axia unit and closes against unwanted back draughts. It can be fitted at the same time as the unit or at a later date if required.

Airflow operated for extract use, cord operated for intake use.

For all models mounted in vertical surfaces.

Motor

Purpose-designed enclosed ball bearing motor. Suitable for running at any angle. Quiet running.

Supply voltage 220-240V/1/50 Hz.

Suitable for operation in ambient temperatures from -40°C to +50°C.

Fitted with Standard Thermal Overload Protection. (S.T.O.P.).

Controller

The Ecotronic Controller is recommended for use with this model to provide full function control of the fan plus the option of sensor mode using a selection of electro-mechanical switches to provide automatic switching of the fan. Alternatively, single speed extract is achieved using a normal On/Off switch.

Model

Size	Stock Ref
S6PL	472442
S7PL	472443
S9PL	472444
S12PL	472445

Accessories

Shutters

Size	Stock Ref
S6SD/R	231710
S7SD/R	232710
S9SD/R	233710
S12SD/R	234710

Dimensions (mm)

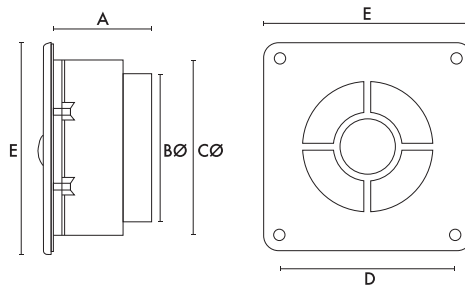

Size	6 in	7 in	9 in	12 in
A	127	137	156	197
BØ	171	210	248	324
CØ	219	250	302	387
D	226	311	311	397
E	254	337	337	419
Fixing Hole Ø	254	337	337	419
Weight kg	2.5	3.0	3.5	5.8

Performance

Model	Extract Performance m ³ /h (l/s) F.I.D.	Watts MAX.	Sound dB(A) @ 3m	Amps @ 240V
S6/PL	354 (98)	32	41	0.16
S7/PL	561 (156)	34	37	0.16
S9/PL	927 (258)	53	45	0.24
S12/PL	1910 (531)	84	48	0.36

Please note that the Standard Range Panel model is not suitable for fitting within an existing Standard Range Wall fitting kit. Please use the correct Standard range Wall Core assembly.

Hygiene



Vent-Axia has been at the forefront of technical innovation for over 75 years and we understand that hand dryer hygiene is essential in our daily lifestyles. We have an extensive hand dryer range suitable for use in many locations, from pubs and restaurants to hotels, schools, service stations and retail centres.

Each of our hand dryer products is powerful yet quiet and all our models come in sleek, elegant designs to blend well into any kitchen, bathroom or WC location. From the powerful fast-speed JetDry Plus to the classic Vent-Axia Dryline+, our hand dryer products are all designed with energy efficiency firmly in mind, saving you as much as 70% of the equivalent cost of paper towels.

For any situation where hygiene, convenience, economy and safety are all key considerations, you can trust Vent-Axia's hand dryer range to deliver the solutions you need.

Jet Dry® Plus

The Jet Dry Plus features a 99.9% HEPA filter and UV sterilization for use in areas where good hygiene is vital.

Vent-Axia®



Restroom

	Jet Dry® Plus	218
	Tempest®	218
	Lo-Carbon eTempest	218
	Ultradry® SX	219
	Powerdry® SX	219
	Dryline+	219
	Ultradry® SX Stainless Steel	219
	Prepdry	219
	Professional E®	219
	Turbodry	220
	Easy Dry	220
	Insect Killers	221

Fast Dry Hand Dryers



Jet Dry® Plus

Automatic double sided high speed jet hand dryer.

- 99.9% HEPA Filter
- UV Sterilisation
- 10 second dry time
- LED indicator
- Removable drip tray
- Lo-Carbon DC Motor, 750W - 2050W
- Ambient Temperature Response Element
- Air speed 95m/s
- Antibacterial coating
- Heater Element 900 - 1300W, adjustable/On/Off
- 700 x 300 x 225mm (H x W x D)
- Weight 9.5kg
- IPX4 Rated
- Sound level: 75dB(A) at 1m
- GS approved
- Cable entry bottom right



Models
Silver
White

Stock Ref
409117
409118



Lo-Carbon eTempest

Automatic hand dryer for fast drying applications.

- 10 second drying time
- Automatically senses work surfaces to avoid nuisance running
- Insulation Earthed Class 1
- Cover: Steel 1.2 mm thick, epoxy coated
- 180 x 250 x 138.5mm (H x W x D)
- Weight: 3.8Kg
- Heater element 500 Watts, adjustable/On/Off
- Unique blue dry zone indicator
- Infrared automatic operation
- Rated at 500kW - 1.2 kW at 230V
- Airflow 113m³/h
- 60 seconds auto shut off
- IPX1 Rated
- Motor: Max 30,000rpm brushed motor
- Soft start
- GS Approved
- Cable entry bottom left



Stock Ref
444956

Tempest®

Automatic no-touch hand dryer for heavy duty applications.

- 10 second drying time
- Automatically senses work surfaces to avoid nuisance running
- Unique blue dry zone indicator
- Cover: Steel. Finish: Polished or satin stainless steel
- Insulation Earthed Class 1
- 277 x 201 x 175mm (H x W x D)
- Weight 6.6kg (packaged)
- Airflow 116m³/h
- Rated at 500W - 1.6kW at 230V
- Heater Element 450 - 900W, adjustable/On/Off
- Infrared automatic operation
- 60 second auto shut off
- IP23 Rated
- Motor speed adjustable
- Motor: Max 18,000rpm brushed motor
- Soft start
- Sound Level: 78dB(A) at 1m
- GS Approved
- Cable entry bottom left



Models	Stock Ref
Satin Stainless	439464
Polished Stainless	439463
White	437231
Filter Assembly Pack	444959
Filter Replacement 2 pack	444960

Hand Dryers



Ultradry® SX

Automatic 'no-touch', vandal resistant hand and face dryer for offices, shops, restaurants, pubs, clubs and hospitals.

- Cover: LM24 pressure die cast aluminium
- Finish: Epoxy/polyester powder coating
- Motor: 5,500rpm, suppressed brushed motor
- Insulation Earthed Class 1
- 264 x 275 x 177mm (H x W x D)
- Weight: 6.0kg (6.6kg packed)
- Sound level: 79 dB(A) at 1m
- Rated at: 2.4kW at 230V
- 28 second drying time
- BEAB Approved
- IP24 Rated
- Cable entry bottom right

Stock Ref

20101800SX



Powerdry® SX

Push button operated hand and face dryer for heavy duty applications in public lavatories, factories, railway stations and schools, etc.

- Cover: LM24 pressure die cast aluminium
- Finish: Epoxy/polyester powder coating
- Motor: 5,500rpm, suppressed brushed motor
- Insulation: Earthed, Class 1
- 264 x 275 x 177mm (H x W x D)
- Weight: 6.0kg (6.6kg packed)
- Sound level: 79 dB(A) at 1m
- Rated at: 2.4kW at 230V
- 28 second drying time
- BEAB Approved
- Supply voltage: 220-240V/1/50-60Hz
- IP24 Rated
- Cable entry bottom right

Stock Ref

20101600SX



Dryline +

Automatic 'no-touch' operation compact hand dryer. Suitable for smaller office washrooms, kitchens and clinics.

- Cover: ABS.
- Motor: 2450rpm shaded pole induction
- Double insulated appliance
- BEAB approved
- 280 x 275 x 143mm (H x W x D)
- Weight: 2.97kg (3.3kg packed)
- Sound level: 46 dB(A) at 3m
- Rated at: 1.7kW at 230V
- 36 second drying time
- Supply voltage: 220-240V/1/50Hz
- IPX1 Rated
- Cable entry bottom right

Stock Ref

453915



Ultradry® SX Stainless Steel

Automatic 'no-touch' hand dryer specially designed for high performance hand drying in food preparation areas and hospital applications and eminently suitable for prestige installations.

- Cover: Satin polished stainless steel
- Motor: 5,500rpm, suppressed brushed motor
- Insulation Earthed Class 1
- 264 x 275 x 177mm (H x W x D)
- Weight: 6.0kg (6.6kg packed)
- Sound level: 79 dB(A) at 1m
- Rated at: 2.4kW at 230V
- 28 second drying time
- BEAB Approved
- IP24 Rated
- Cable entry bottom right

Stock Ref

20101840SX



Prepdry-Stainless Steel

Designed for food preparation areas and hospital applications where the highest levels of hygiene have to be observed. Automatic 'no-touch' hand dryer.

- Cover: Satin polished stainless steel
- Motor: External Rotor Brushless Motor 2700 rpm
- Insulation Earthed Class 1
- 280 x 270 x 148mm (H x W x D)
- Weight: 4.0kg (4.5kg packed)
- Sound level: 65 dB(A) at 1m
- Rated at: 2.0 kW at 240V
- 31 second drying time
- Supply voltage: 220-240V/1/50Hz
- BEAB Approved
- IP24 Rated
- Cable entry bottom right

Stock Ref

20101440



Professional E®

Automatic 'no-touch' hand dryer for smaller office washrooms, kitchens and clinics.

- Cover and base: High gloss, fire retardant ABS/polycarbonate alloy
- Motor: 2700rpm external rotor, brushless motor
- Double insulated appliance
- 262 x 261 x 141mm (H x W x D)
- Weight: 3.09kg (3.52kg packed)
- Sound level: 65 dB(A) at 1m
- Rated at: 2.0 kW at 240V
- 31 second drying time
- BEAB Approved
- Supply voltage: 220-240V/1/50Hz
- IP24 Rated
- Cable entry bottom right

Stock Ref

20101402



Hand Dryers



Turbodry® White Auto

Automatic hand & face dryer for heavy duty applications where a robust secure design is required.

- Cover: Steel.
- Finish porcelain enamel coating
- Insulation Earthed Class 1
- 248 x 284 x 202mm (H x W x D)
- Motor: 5,500rpm brushed motor
- Weight 7.5kg
- Sound level 70 dB(A) @1m
- Rated at 2.4kW @ 230 V
- 26 second drying time
- GS Approved
- Unique blue dry zone indicator
- IP23 Rated
- Cable entry bottom left

Stock Ref
435427



Turbodry® White Manual

Push button hand & face dryer for heavy duty applications where a robust secure design is required.

- Cover: Steel.
- Finish: porcelain enamel coating
- Insulation Earthed Class 1
- 248 x 284 x 202mm (H x W x D)
- Motor: 5,500rpm brushed motor
- Weight 7.5kg
- Sound level 70 dB(A) @1m
- Rated at 2.4kW @ 230 V
- 26 second drying time
- GS Approved
- Unique blue dry zone indicator
- IP23 Rated
- Cable entry bottom left

Stock Ref
435424



Turbodry® Steel Auto

Automatic hand & face dryer for heavy duty applications where a robust secure design is required.

- Cover: Steel.
- Finish: Polished Stainless Steel
- Insulation Earthed Class 1
- 248 x 284 x 202mm (H x W x D)
- Motor: 5,500rpm brushed motor
- Weight 7.5kg
- Sound level 70 dB(A) @1m
- Rated at 2.4kW @ 230 V
- 26 second drying time
- GS Approved
- Unique blue dry zone indicator
- IP23 Rated
- Cable entry bottom left

Stock Ref
435430



Easy Dry Range

An economical ABS or Metal covered automatic dryer, designed for use in applications where good performance linked with price sensitivity is of paramount importance.

- 2500 - 4200rpm induction motor
- Insulation Earthed Class 1
- 225 x 275 x 160mm (H x W x D)
- Weight: ABS Models - 3.3kg (3.65kg packed), Metal Models - 4.7kg (5.5kg packed)
- Sound levels: 54 dB(A) at 1m
- Rated: 1.0kW, 1.25kW or 2kW at 240V
- 30 seconds drying time
- Supply voltage: 220-240V/1/50Hz
- GS Approved
- IP22 Rated
- Cable entry bottom right

Models	RPM	Stock Ref
1.0kW ABS	2500	427935
1.25kW ABS	2500	436297
1.25kW+Metal	2500	431515
2.0kW+Metal	4200	427936



Insect Killers



Portable Insect Killer

- High efficiency long life (50,000 hrs) LED bulbs for attracting insects
- ABS fire proof plastic for high safety
- Micro switch for high safety
- Extract fan for high efficiency
- Includes brush for cleaning and maintenance
- Approved to EN60335-2-59 CE/GS/ROHS
- Weight: 0.7kg
- Coverage: 50m²
- Watts: 5.5W

Model	Stock Ref
Portable Insect Killer	446877



IK50

- Durable ABS fire proof plastic on side panels
- Large removable collection tray for easy cleaning
- High quality aluminium, easy to clean. Crack, fade, scratch and oil resistant
- Fully protected outer mesh
- Energy efficient UV-A lamp
- Free standing, suspend or hang from wall
- Approved to EN60335-2-59 CE/GS/ROHS/REACH/PAH(TUV)
- Weight: 1.83kg
- Coverage: 50m²
- Watts: 2x 8W

Model	Stock Ref
IK50	446878
Spare Bulb	446937



IK80

- Durable ABS fire proof plastic on side panels
- Large removable collection tray for easy cleaning
- High quality aluminium, crack, fade, scratch and oil resistant
- Fully protected outer mesh
- Energy efficient UV-A lamp
- Free standing, suspend or hang from wall
- Approved to EN60335-2 59 CE/GS/ROHS/REACH/PAH(TUV)
- Weight: 2.6kg
- Coverage: 80m²
- Watts: 2x 10W

Model	Stock Ref
IK80	446879
Spare Bulb	446938



IK150

- Durable ABS fire proof plastic on side panels
- Large removable collection tray for easy cleaning
- High quality aluminium, easy to clean. Crack, fade, scratch and oil resistant
- Fully protected outer mesh
- Energy efficient UV-A lamp
- Free standing, suspend or hang from wall
- Approved to EN60335-2 59 CE/GS/ROHS/REACH/PAH(TUV)
- Weight: 3.60kg
- Coverage: 150m²
- Watts: 2x 20W

Model	Stock Ref
IK150	446880
Spare Bulb	446939

Cooling



Hi-Line Plus

For use in a variety of commercial and industrial applications, the Hi-Line Plus provides effective and positive air movement to improve the working environment.

Vent-Axia[®]





Jupiter

224



Hi-Line Plus®

225



Portable Air Conditioner

226



12" Wall Fan

227



Box Fan

227

Jupiter De-Stratification Unit

Features & Benefits

- Available in two sizes
- Speed controllable
- High velocity fans
- Supplied with a grey coated finish - other colours available to special order
- Available with built-in thermostat



Air Movement Fans

The Vent-Axia Jupiter range of de-stratification units is based on direct drive axial fans, housed in a neat and sturdy casing complete with eyebolts for suspension from chains or steel wires. Ideal for applications where the proposed mounting height requires higher velocity fans or where open bladed ceiling fans are considered unsuitable. Jupiter fans can be used in stores, warehouses, factories, workshops, as well as many other industrial applications. The unit provides effective and positive air movement to improve the working environment, particularly during summer months. In addition Jupiter fans can be used during the winter to re-circulate hot air from ceilings and roofs down to living and working areas.

Electrical

Supply voltage 220-240V/1/50Hz. Direct drive axials with speed controllable motors. The motor hub and impeller are statically and dynamically balanced for smooth operation and optimum performance. Class F insulation, suitable for operating in atmospheres of up to 95% RH and ambient temperature of up to +60°C.

General Installation

For cooling effect, circulation of air is required in any given area. As a guide, mount Jupiter fans 4.5-6m apart, in tropical climates 3m apart. Fans should be mounted so that they do not interfere with lighting installations in any way. Mount fans away from walls or pillars where possible to avoid obstruction of airflow.

Heat Saving

Heat savings are largely dependent on the difference between the roof level and the working level temperatures, the ventilation rate and the geographical position.

Models

Model	Stock Ref
NJUP315	457485

NJUP315CTS	457486
NJUP400	457487
NJUP400CTS	457488

Accessories

Model	Stock Ref
Speed Controller	RTRE20
ThermoSwitch	563502
Suspension Pack	457490

Dimensions (mm)

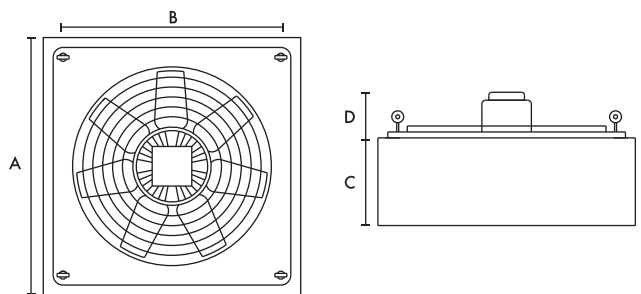

Size	A	B	C	D	Weight
315	500	380	200	84	11 kg
400	620	490	200	93	16 kg

Performance

Models	Duty CFM	Speed m ³ /s	RPM	dB(A) @3M	220/240V/50Hz/1Ph kW	FLC	SC	Max Mounting Height	
								Feet	Metres
NJUP315/CTS	1290	0.610	1380	45	0.15	0.70	2.50	44	13.4
NJUP400/CTS	3000	1.415	1320	51	0.35	1.60	5.50	72	22.0

Hi-Line Plus Ceiling Sweep Fans

Features & Benefits

- Suitable for winter de-stratification applications or summer cooling
- Three sweep diameters: 900mm, 1200mm, and 1400mm
- Two down rod lengths included
- Easy to install
- Quiet running
- Can be installed for either upward or downward airflow
- Reversible electronic controller available



De-stratification Fans

Hi-Line Plus ceiling fans can be used in offices, stores, shops, foyers, schools, hospitals, kitchens, restaurants and many industrial applications such as warehouses, factories, tanneries and workshops. Hi-Line Plus fans will provide effective and positive air movement to improve the working environment particularly during summer months. In addition, Hi-Line Plus fans can be used during winter months to re-circulate hot air from ceilings areas down to living and working areas thus helping to conserve energy.

An infinitely variable speed controller is available for use with one or a combination of models up to 5 units. Alternatively, Hi-Line Plus fans may be wired directly to a normal On/Off switch. For maximum benefit, good ventilation is vital, we advise that Hi-Line Plus fans are used in conjunction with Vent-Axia T-Series or Standard Range ventilation units.

Hi-Line Plus blades are produced from sheet steel and individually weighed to produce matched sets.

Motor

The motor is totally enclosed, capacitor start and run. Suitable for temperatures up to +40°C. Supply Voltage 220-240V/1/50Hz.

Fan Selection

For energy conservation fan selection is dependent upon area and mounting height. Estimate the height at which the fan can be mounted and then calculate the relevant fan size from the table below. Move to meet the diagonal line and then read down to find out how much floor area per fan is suitable.

Down Rods

The Hi-Line Plus fans include both a long and short down rod packaged as standard. The total drop length of the short down rod including motor is 360mm. The total drop length of the long down rod including motor is 610mm.

Models

Model	Stock Ref
HL 90	428049
HL 120	428050
HL 140	428051

Ceiling Fan Controller

SAC5 Reversible Controller

The Vent-Axia ceiling fan controller adds extra flexibility to all Hi-Line Plus installations. Fan speeds can be selected to suit varying conditions. This is of particular benefit where mounting height is low. The controller is designed to be used with a single fan or up to 5 Hi-Line fans.

The controller is infinitely variable, has solid state components, an insulated spindle, white cover plate and can be flush or surface mounted. Suitable for commercial environments.

Hi-Line Plus fans should be used only with a Vent-Axia ceiling fan controller or an On/Off switch. Supply Voltage 220-240V/1/50Hz.

Stock Ref
428238

For completely silent running we recommend the use of a 5 step transformer. Suitable for up to 9 ceiling sweep fans.

Stock Ref
10314103

Performance

Model	Sweep		Air Displacement	Max.	Amps	RPM
	Dia. mm	Colour	m ³ /h	Watts	@240V	
HL 90	900	White	8100	41	0.176	335
HL 120	1200	White	12600	52	0.235	315
HL 140	1400	White	15000	65	0.285	295

Weight approximately 7kg.

Portable Air Conditioner

Features & Benefits

- Environmentally friendly, R410A refrigerant
- Does not require specialist installation
- Built-in 24 hour timer
- Effective cooling for homes and offices
- Double insulated cable with moulded UK plug



Compact Cooling

The Portable Air Conditioning unit from Vent-Axia provides mobile comfort air-conditioning, dehumidifying or heating anywhere, anytime. Simply plug in and switch On. Perfect for domestic and light commercial use such as offices, shops and reception areas where permanently installed air conditioning systems may be too inflexible and expensive.

Model

3 in 1 Portable Air Conditioner

The 3 in 1 unit is a self contained floor standing portable air conditioner which does not require a separate outdoor unit or specialist installation.

- 3 in 1 - choose from cooling, dehumidifying and fan only options
- 16°C-30°C temperature setting
- 24 hour timer
- Micro-processor control
- R410A CFC free refrigerant
- 12,000 btu/h cooling
- Double insulated cable with moulded UK plug



Stock Ref

448919

Specifications

Model	3 in 1
Cooling capacity kW (btu/hr)	3.46 (12,000)
Dehumidification - litres/hr	0.95
Condensate disposal	Tank or Hose
Power input - Watts	1340
Power supply - via 13 Amp plug & socket	230V, 1ph, 50Hz
Dimensions - (HxWxD) mm	765 x 345 x 300
Flexible hose length - mm/diameter - mm	1500/150
Refrigerant	R410A

Vent-Axia Cooling



12" Wall Fan

Quiet motor operation, 3 speeds with oscillation and free neck. Ideal for wall fixing, 8 hour On/Off timer. Infra-red remote control sensor, double insulated cable with moulded UK plug.



Stock Ref

427583



Box Fan

Quiet motor operation, floor standing model, 3 speed options. 360° louvre rotating air circulation, upward or downward tilt adjustment. Double insulated cable with moulded UK plug.



Stock Ref

427584

Electric Heating



Vent-Axia heating is ideal for residential or commercial applications. So whether it's a bedroom or hallway, office or shop, we can provide the solution.

The simplicity of installing electric heating, particularly in high rise apartments means it is the natural choice for your project.

Comfort Heating products with innovative zone control features provide energy savings for the occupier without compromising comfort in the home, coupled with low capital outlay they offer a cost effective solution for both parties.

With a slim, stylish design our Opal Aluminium Radiator range offers households attractive, energy efficient comfort. Featuring an advanced digitally controlled thermostat, the Opal range gives you one of the most cost effective and energy efficient electric heating systems available.

Vent-Axia[®]





Bluethermal® Underfloor Heating

230-235



Heated Towel Rails

236-237



Radiant Heaters

238-239



Opal Aluminium Radiators

240



Optimax® Plus Panel Heaters

241



Optimax® Plus Combination Storage Heaters

242



Optimax® Plus Storage Heaters

243



Plinth Heaters

244



Warm Air Curtains

245



Convector Heater

246



Portable Fan Heater

247

Bluethermal Underfloor Heating Mat

Features & Benefits

- Energy efficient
- Maintenance free
- Zone controllable
- Easy to install adhesive mats
- Offers design freedom by removing radiators
- 100W/m² & 150W/m² options available
- 2.5m cold lead cable
- Controller & insulation board available
- 10 Years warranty

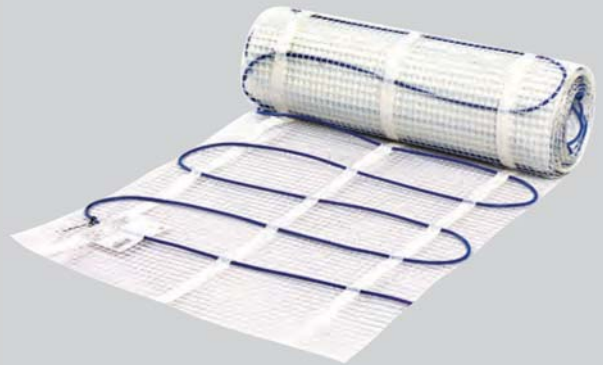

Bluethermal Mat Thin Twin Conductor Heating Mat Renovating with Heating Mats

Minimum floor thickness can be important in renovation processes in order to avoid extra work on doors and thresholds. For these projects our Bluethermal[®] Mat range is the ideal product. The heating mat consists of a thin twin conductor heating cable attached to an adhesive flexible glass fibre net. The thin heating cable has a total thickness of only 4mm, is delivered with a 2.5m cold lead and has a width of 0.5m.

The 100W/m² mat can be installed on any type of levelled and stable sub floor, and can also be used under parquet or other wooden floor coverings. The 150W/m² must be installed on a non-combustible levelled and stable sub floor. With all our products we recommend the use of our Bluethermal[®] Thermostatic Controller thermostat with a temperature limiting function.

10 year Warranty

Vent-Axia offers a 2 year standard warranty on underfloor heating and their components from the date of purchase. A 10 year extended warranty is also available upon completing the 'Warranty Form' found in the Fitting and Wiring Instructions.

Construction:

- Solid resistance wires
- FEP insulation
- Solid copper earth wire
- Fibre-glass net
- PVC outer jacket
- Aluminium sheath
- Cable thickness is 4mm
- Mat width 0.5m (19.7")

Technical Data:

- Area load 100W or 150W/m² (9.3 or 14.0W/sq.ft.)
- Loads from 100W to 1800W
- Max. continuously operating temperature outer jacket: 65°C
- Tolerance on conductor resistance: -5 / + 10 %
- Rated voltage: 230V

Installation Detail

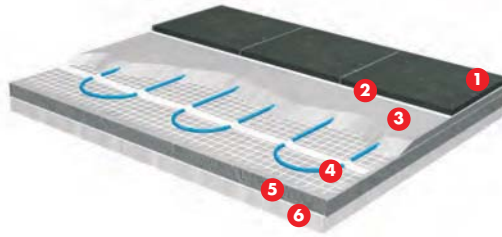

- 1 Floor covering
- 2 Tile adhesive
- 3 Recommended screed depth 10-30mm
- 4 Bluethermal® Mat 4mm
- 5 Insulation board
- 6 Stable and levelled sub-floor

Performance Guide

Stock Ref	Model	Mat Area m ²	Output W	Dimensions m W	Dimensions m L	Element Nom. Resistance Ω
446175	VAUFHM 100	1.0	100	0.5	2	529.0
446176	VAUFHM 100	1.5	150	0.5	3	352.7
446177	VAUFHM 100	2.0	200	0.5	4	264.5
446178	VAUFHM 100	2.5	250	0.5	5	211.6
446179	VAUFHM 100	3.0	300	0.5	6	176.3
446180	VAUFHM 100/HS	3.5	350	0.5	7	151.1
446181	VAUFHM 100/HS	4.0	400	0.5	8	132.3
446182	VAUFHM 100/HS	5.0	500	0.5	10	105.8
446183	VAUFHM 100/HS	6.0	600	0.5	12	88.2
446184	VAUFHM 100/HS	7.0	700	0.5	14	75.6
446185	VAUFHM 100/HS	8.0	800	0.5	16	66.1
446186	VAUFHM 100/HS	10.0	1000	0.5	20	52.9
446187	VAUFHM 100/HS	12.0	1200	0.5	24	44.1
446188	VAUFHM 150	1.0	150	0.5	2	352.7
446189	VAUFHM 150	1.5	225	0.5	3	235.1
446190	VAUFHM 150	2.0	300	0.5	4	176.3
446191	VAUFHM 150/HS	2.5	375	0.5	5	141.1
446192	VAUFHM 150/HS	3.0	450	0.5	6	117.6
446193	VAUFHM 150/HS	3.5	525	0.5	7	100.8
446194	VAUFHM 150/HS	4.0	600	0.5	8	88.2
446195	VAUFHM 150/HS	5.0	750	0.5	10	70.5
446196	VAUFHM 150/HS	6.0	900	0.5	12	58.8
446197	VAUFHM 150/HS	7.0	1050	0.5	14	50.4
446198	VAUFHM 150/HS	8.0	1200	0.5	16	44.1
446199	VAUFHM 150/HS	10.0	1500	0.5	20	35.3
446200	VAUFHM 150/HS	12.0	1800	0.5	24	29.4

*HS = hidden splice

The mats are equipped with a 2.5m cold lead

Convection Heating and Underfloor Heating Comparison

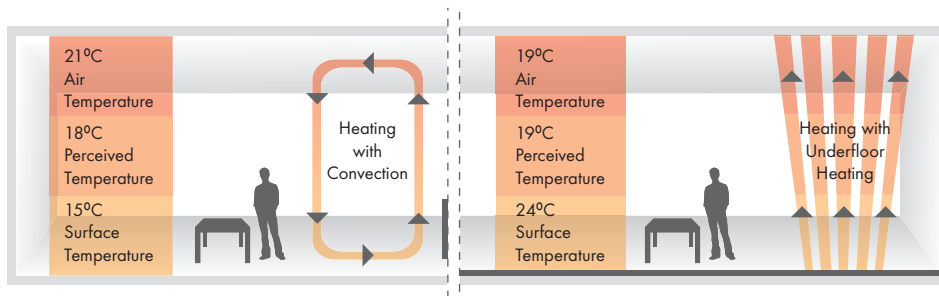

Bluethermal Underfloor Heating Cable

Features & Benefits

- Energy efficient
- Maintenance free
- Zone controllable
- Allows for application in tight areas
- Offers design freedom by removing radiators
- 100W/m² & 150W/m² options available
- 2.5m cold lead cable
- Controller & insulation board available
- 10 Years warranty



Bluethermal Cable Twin Conductor Cable For Direct Heating Renovation with Heating Cables

When renovating with our Bluethermal® Cable range, apply the cable to a non-combustible subfloor (minimum thickness 5mm) and take into consideration the placement of permanent installations such as showers, baths, toilets, cupboards etc. Place the end seal away from potentially wet areas of the floor. See 'Installation Example' on the next page detailing the placement of a free laid heating cable. Note that the cable is not crossing or touching itself, this is to provide the best possible heat conductivity to the surroundings of the cable.

The heating cable is embedded in a screed/concrete with low overall construction height. After drying and hardening, a moisture barrier/membrane can be put on top of the screed/concrete before the floor covering is installed.

10 year Warranty

Vent-Axia offers a 2 year standard warranty on underfloor heating and their components from the date of purchase. A 10 year extended warranty is also available upon completing the 'Warranty Form' found in the Fitting and Wiring Instructions.

Construction:

- Solid resistance wire
 - XLPE insulation
 - Tinned copper drain wire
 - Aluminium screen
 - PVC outer jacket
 - Cable thickness is 7mm
-

Technical Data:

- Series resistance, element values from 300W to 3300W
- Linear load: 17W/m (5.2W/ft)
- UV resistant
- Max. cont. operating temperature outer jacket: 65°C (149°F)
- Min. bending radius: 5 x cable diameter
- Tolerance on conductor resistance: - 5 / + 10 %
- Highest system voltage: 300/500V
- Rated voltage: 230V

Installation Detail

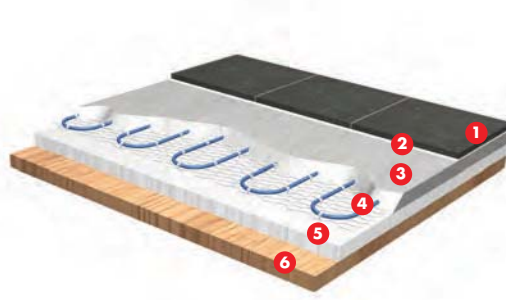

- 1 Floor covering
- 2 Tile adhesive
- 3 Recommended screed depth 40-60mm
- 4 Bluethermal® Cable 7mm
- 5 Insulation board
- 6 5-10mm stable and levelled subfloor

Performance Guide

Stock Ref	Model	Load @ 230V		Element length		Element Nom	Outer diameter
		W	m	ft	Resistance Ω	mm	
446201	VAUFHC	300	17.6	58	176.30	7	
446202	VAUFHC	400	23.5	77	132.30	7	
446203	VAUFHC	500	29.3	96	105.80	7	
446204	VAUFHC	600	35.2	115	88.20	7	
446205	VAUFHC	700	41.0	135	75.60	7	
446206	VAUFHC	840	49.7	162	63.00	7	
446207	VAUFHC	1000	58.3	191	52.90	7	
446208	VAUFHC	1250	72.4	237	42.30	7	
446209	VAUFHC	1370	80.8	265	38.60	7	
446210	VAUFHC	1700	100.0	328	31.10	7	
446211	VAUFHC	2100	123.7	405	25.20	7	
446212	VAUFHC	2600	154.5	507	20.30	7	
446213	VAUFHC	3300	194.0	615	16.00	7	

The cables are equipped with a 2.3m cold lead

Convection Heating and Underfloor Heating Comparison

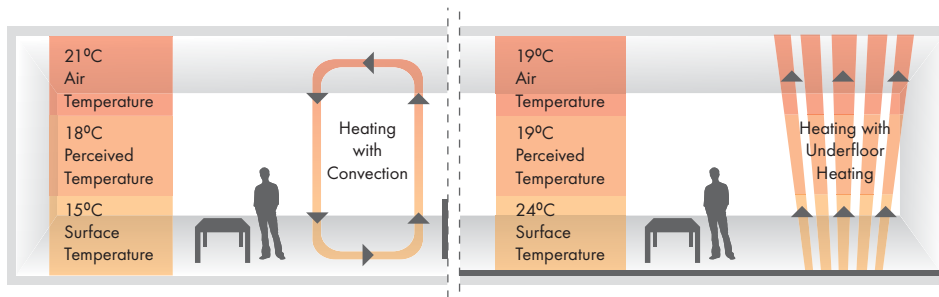

Installation Example

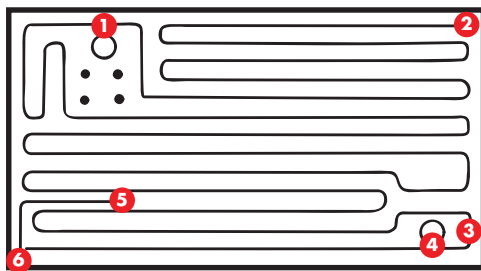

- 1 Cable laid behind the toilet to dry up condensation
- 2 End seal preferably placed in a dry zone of the floor
- 3 Put some distance between drain and cable to avoid excessive dryness of gully and odour problems
- 4 Drain/gully
- 5 Floor sensor
- 6 Transition between heating cable and cold end attachment

Bluethermal Thermostatic Controller

Features & Benefits

- Large screen with blue backlighting
- 4-event programme or constant temperature control
- Clock: 12 hours (am/pm) / 24 hours
- Day display: Monday - Sunday
- Celsius or fahrenheit display selection
- Frost protection setting
- 5 - 40°C working range (default)



Applications

Precise and accurate temperature control is important to fully achieve the advantages of underfloor heating, without using more electric energy than necessary.

The use of heating mats and cables in combination with an accurate thermostat can provide an energy efficient and comfortable floor heating solution for most modern buildings.

Specifications

- Accuracy: +0.5°C / 1°F
- Maximum load: 16A or 3.2kW
- Power supply: 230V
- Dimensions: 86 x 86 x 13mm (WxHxD)
- IP24 rated

Model VAUFHTC Stock Ref 446174

Splicing Kit

In the unlikely event that you need to repair your heating cables, this kit provides you with the necessary joints to get your systems back running.

Model VAUFHS Stock Ref 446214

Recommended Application Guide

Application	Output Min W/m ²	Output Max W/m ²	Model		
			VAUFHM 100	VAUFHM 150	VAUFHC
Entrance/Hall	80	150	X		X
Entrance/Porch	120	150		X	X
Hall/Corridor	80	100	X		X
Living Room	70	100	X		X
Kitchen	70	100	X		X
WC	120	150		X	X
Utility Room	120	150		X	X
Bedroom	70	100	X		X
Bathroom	120	150		X	X
Office	80	100	X		X
Storage Room	80	100	X		X
Shop	80	100	X		X
Workshop	80	100	X		X

Bluethermal Insulation Boards

Features & Benefits

- Increases the Efficiency of Any Underfloor Heating System
- Variety of Sizes to Suit Any Project
- Minimizes downwards heat loss.

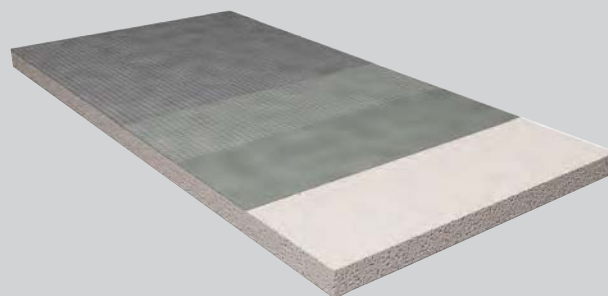

Applications

Our insulation boards limit the downward heat loss within the system directing the heat to where you need it.

Vent-Axia underfloor heating insulation boards are recommended for use with our products to increase the efficiency and minimise the warm up time of the system, saving both energy and money. They are available from 6mm to 70mm thick.

Fixing to Wooden Floors

By Adhesive - The boards must be laid onto a level floor, with a suitable flexible rapid set cementitious tile adhesive - solvent based or ready mixed adhesives **MUST NOT** be used.

By Mechanical Fixing - The boards (other than 6mm boards) can be installed with mechanical fixings only to flat and level timber floors using approximately 12 fixings per 1200mm x 600mm board, with suitable screws and a 35mm fixing washer under the head. Fixing kits are available as detailed in the table to the right.

Fixing to Concrete Floors

A suitable flexible rapid set cementitious tile adhesive should be used - solvent based adhesives or ready mixed adhesives **MUST NOT** be used.

Vent-Axia Underfloor Heating Insulation Boards

Stock Ref	Model	Thickness mm	Number of boards per box	Pack coverage m ²	U-Value W/m ² /K
447267	VAUFHIB6	6	8	5.76	4.5
447268	VAUFHIB10	10	6	4.32	2.7
447269	VAUFHIB12	12.5	6	4.32	2.16
447270	VAUFHIB20	20	6	4.32	1.35
447271	VAUFHIB30	30	4	2.88	0.9
447272	VAUFHIB40	40	3	2.16	0.67
447273	VAUFHIB50	50	2	1.44	0.54
447274	VAUFHIB60	60	2	1.44	0.45
447275	VAUFHIB70	70	2	1.44	0.39

Vent-Axia Underfloor Heating Insulation Board Accessories

Stock Ref	Model	Type	To be used with insulation board	Size
447277	VAUFHIB10S	Screws *	VAUFHIB6-12	25mm (L)
447278	VAUFHIB20S	Screws *	VAUFHIB20	35mm (L)
447279	VAUFHIB30S	Screws *	VAUFHIB30	45mm (L)
447280	VAUFHIB40S	Screws *	VAUFHIB40	60mm (L)
447281	VAUFHIB50S	Screws *	VAUFHIB50	65mm (L)
447282	VAUFHIB60S	Screws *	VAUFHIB60	75mm (L)
447283	VAUFHIBW	Washers *	All	35mmØ
447276	VAUFHIBT	Tape	All	100mm (W) x 50m roll (L)

* (50 per pack)

Heated Towel Rails

Features & Benefits

- IP55 rated
- Wall fixings included
- Plug and vent included
- Five year leakage warranty
- One year manufacturer's guarantee
- Heating element included
- Stylish designs
- Steel construction with high quality white and chrome finishes
- Production is carried out using latest technology resulting in absolute consistency in quality
- Complete fitting set supplied



Range Options

Vent-Axia Heated Towel Rails quickly warm and dry towels. Their presence on the wall also adds to the overall style, temperature and comfort of the room.

This comprehensive range of white and chrome towel rails offers 10 different models across the flat, curved and designer ranges. The range offers sizes from 500 x 600mm to 500 x 1500mm available in four heat outputs of 100, 150, 250 and 400W matched to the size of the rail.

Controller

The range is complemented by an advanced controller available in white and chrome giving you control of five heat outputs. The controller also offers an eco mode ideal for use when drying your towels to ensure minimal energy use. This feature turns on the rail on full power for 30 minutes then reduces the output to the user setting for a further 90 minutes before turning the towel rail off.



- IPX4 rated
- White or chrome finish
- Five power settings
- Eco timed function
- Two year warranty

Model

VATRCW White

VATRCC Chrome

Stock Ref

447864

447865

Heated Towel Rail Range

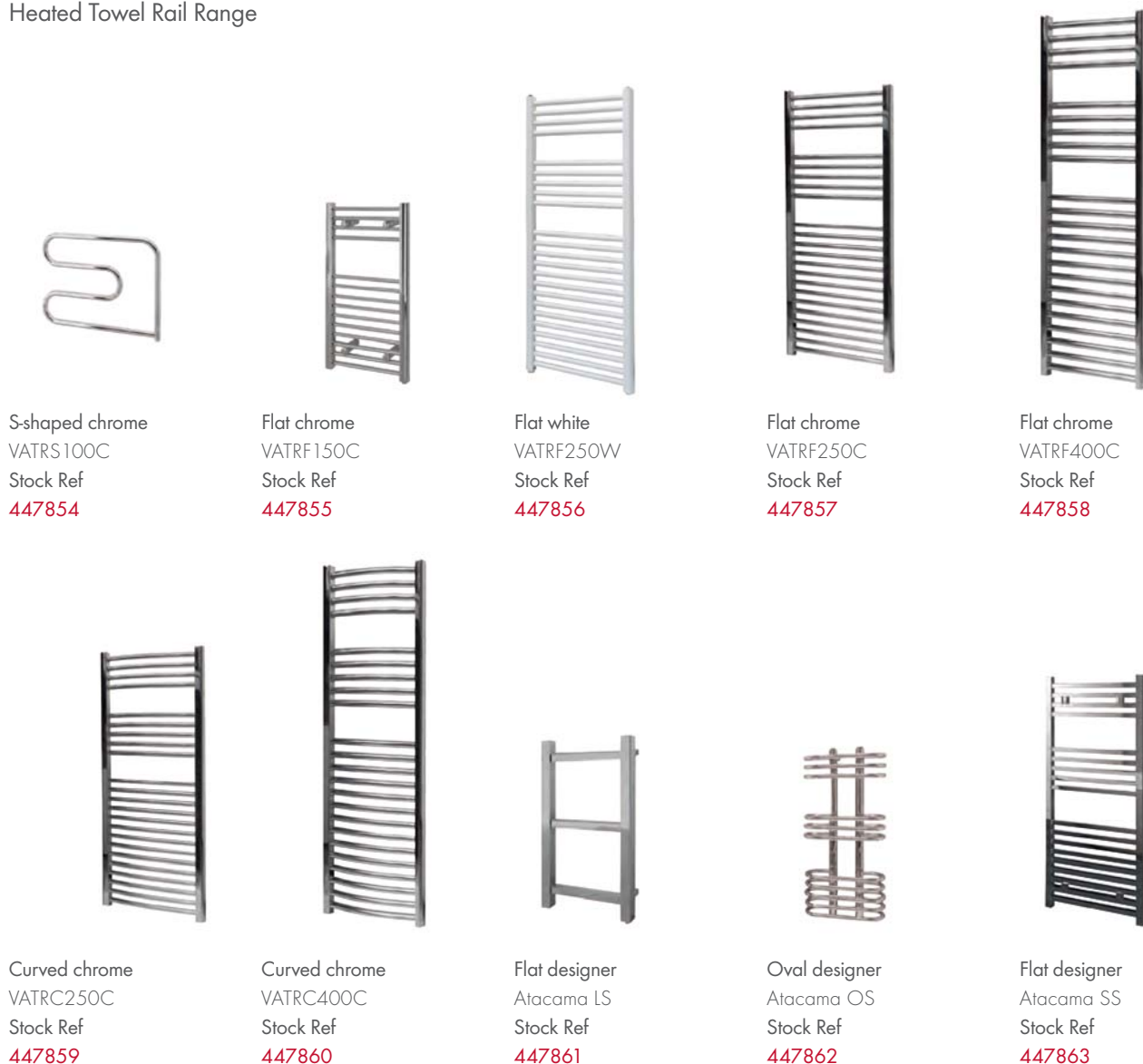

Specification

Stock Ref	Model	Description	Finish	Dimensions mm		Output
				W	H	W
447854	VATRS100C	'S' Shape	Chrome	600	500	100
447855	VATRF150C	Flat	Chrome	400	700	150
447856	VATRF250W		White	500	1100	250
447857	VATRF250C		Chrome	500	1100	250
447858	VATRF400C		Chrome	500	1500	400
447859	VATRC250C	Curved	Chrome	500	1100	250
447860	VATRC400C		Chrome	500	1500	400
447861	Atacama LS	Designer	Chrome	400	700	150
447862	Atacama OS		Chrome	300	650	150
447863	Atacama SS		Chrome	500	1000	250
447864	VATRCW	Controller	White	single gang		n/a
447865	VATRCC		Chrome	single gang		n/a
447866	VATRDFK150	Replacement element / dual fuel kit	n/a	n/a		150
447867	VATRDFK250		n/a	n/a		250
447868	VATRDFK400		n/a	n/a		400

Radiant Heaters

Features & Benefits

- Economical and easy to install
- Silent in operation
- No yearly maintenance cost
- Shortwave IR halogen lamp
- One second heat up time
- Precision heating directed where you need it
- Up to 5000 hours element life span
- IP65 rated (VARO model)



Profile

Our radiant heating product range gives the flexibility to deal with large and small unheated spaces which would be uneconomical to heat using traditional space heating.

Areas such as bars, restaurants, terraces, delivery areas, warehouses and churches are some examples where our radiant heating products will provide an economical heating solution.

Radiant heat and its advantages

The heat we feel from the sun is called radiant heat and is part of the electromagnetic spectrum called infrared. Ultra violet and visible light also belong to the same family.

Visible light is the easiest part of this spectrum to understand, light travels in a straight line from the source, is unaffected by air and is invisible until it hits a surface. Shadows are a good example of this and are the absence of light.

Infrared rays behave in the same way, we cannot see them but we can feel them as warmth. A good example of this is the effect created when you move from the shade into the sun, although the temperature is the same, the perceived temperature when in direct sunlight is much higher. This phenomenon makes sunbathing possible during winter holidays.

There are three categories of infrared; short wave (IR A), medium wave (IR B) and long wave (IR C), the shorter the wave length the easier it travels through the air.

The advantage when using short wave infrared heating is that the rays cut through the air and are not affected by air movement and only transmits its energy when it collides with a solid object. The rays also travel in a straight line so can be directed where you need it, ideal in locations which feature high ceilings, have high air change rates or are outside.

Convection Heating and Radiant Heating Comparison

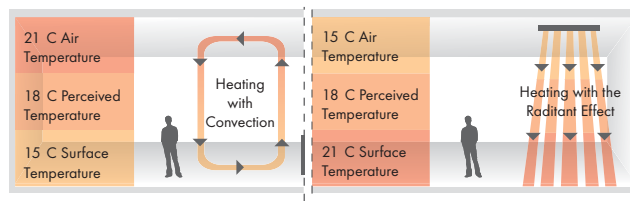

Wave Infrared comparison

	Short Wave Infrared	Medium Wave Infrared	Long Wave Infrared
Typical source	IR Halogen Lamp	Quartz Heat Source	Resistance
Materials	Tungsten Filament welded in a quartz tube	Filament in compound of Fe-Cr-Al in a quartz tube	Filament in compound of Fe-Cr-Al in a steel tube
Radiant efficiency	92%	60%	40%
Switch on/off times	1 second	30 second	5 minutes

Radiant Heater Range



Model
VARO 1800

Stock Ref
447600



Model
VARI 2000

Stock Ref
447602



Model
VARI 4000

Stock Ref
447603



Model
VARI 6000

Stock Ref
447604

Dimensions (mm)

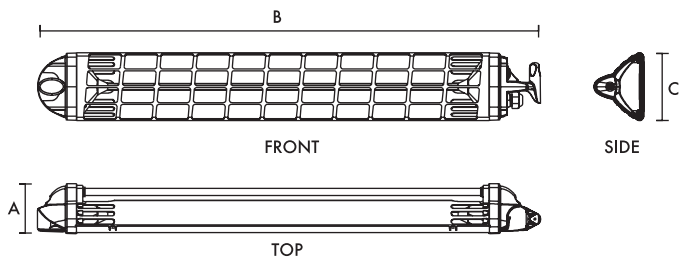

Stock Ref	A	B	C
447600	83	836	112

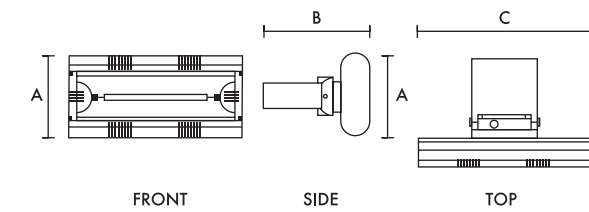

Stock Ref	A	B	C
447602	235	313	486
447603	376	313	496
447604	515	313	496

Technical Details

Stock Ref	Model	Weight kg	Voltage rating	Bulb	Luminous spectrum	Accessories	Output W	Amps	Heating range m ²	Replacement elements
447600	VARO 1800	1.0	230V ~ 50-60Hz	gold x1	IR-A	wall bracket	1800	8	8-10	VARO 447606
447602	VARI 2000	2.2	220-240V - 50-60Hz	gold x1	IR-A	wall bracket	2000	9	9-12	VARI 447605
447603	VARI 4000	3.0	220-240V - 50-60Hz	gold x1	IR-A	wall bracket	4000	18	12-16	VARI 447605
447604	VARI 6000	3.8	380-415V - 50-60Hz	gold x1	IR-A	wall bracket	6000	27	16-20	VARI 447605

Opal Aluminium Radiators

Features & Benefits

- Aluminium block with innovative curved elements
- Digitally controlled thermostat
- Dynamic fluid with high thermal inertia
- Temperature setting; Comfort, Economy, Anti-Freeze
- Seven pre-set heating schedules, including two programmable options
- Outputs from 500W - 1500W
- Safety thermal regulator
- Supplied with wall mounting brackets and 0.7m power cable
- IP24 Rated
- Safe, clean and easy to operate
- All radiators are powder coated externally in white (RAL 9016)



Applications

The Vent-Axia Opal range of Aluminium Radiators offers a slim stylish design with advanced digital thermostatic control giving you one of the most cost effective and energy efficient electric heating system you can have.

Popular with specifiers, contractors and home owners, the Opal range is ideal for new build and refurbishment.

Available in five sizes, our range provides a solution for any size room with outputs from 500W - 1500W.

All of the Opal Aluminium Radiators controllers are fully programmable offering closer management of energy control with resultant costs savings. This can be measured with the on-board energy monitor allowing you to see how much energy you are using to heat your room. All standard units come with all the features and controls you would expect to see on an advanced heating system.

Energy Saving Electronic Control

Accurate, fast acting control is essential for reducing temperature overrun and minimising energy consumption.

The silent operating electronic thermostat is accurate to +/- 0.5°C and acts quickly to maintain consistent temperature levels.

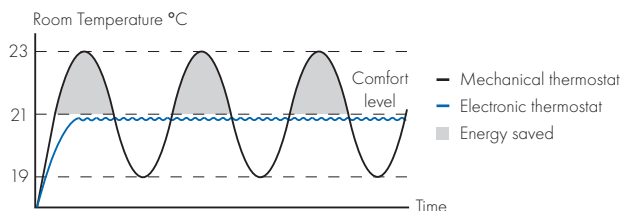

Seven Pre-set Lifestyle Heat Schedules

The heater is pre-programmed with seven heating plans, with two of them being adjustable to meet your own needs. The five pre-set programmes are adapted to most heating situations. The seven plans are described in the table on the right.

Heating schedule PLnF is pre-programmed for when you are away from your home for a long period of time and would like to protect it against freezing. The green economy LED will flash.

Heating schedule PLUE is designed for weekends. With this plan the heater is pre-programmed to work from Monday to Thursday in the antifreeze position. From Friday through to Sunday you can configure the programme according to your own needs.

Should the pre-set schedules not meet your heating requirements, the PLCF heating plan enables you to create your own heating schedule.

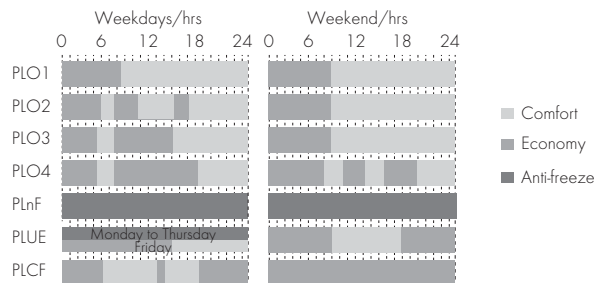

Specification

Stock Ref	Model	Weight kg	Dimensions (mm)			Output	
			H	W	D	W	Amps
448469	VAAR500 500W	11	584	460	96	500	2.3
448470	VAAR750 750W	15	584	620	96	750	3.4
448471	VAAR1000 1000W	19	584	780	96	1000	4.5
448472	VAAR1250 1250W	23	584	940	96	1250	5.7
448473	VAAR1500 1500W	27	584	1100	96	1500	6.8

Optimax Plus Panel Heater

Features & Benefits

- Integral adjustable thermostat
- Optional integral timer model
- Frost protection setting of 5°C
- BEAB approved
- Unique quick fix wall bracket
- Colour RAL 9001
- Ideal complement to storage heaters
- Brackets for panel included
- IP24 rated



Comfort Heating

Our Optimax Plus Panel Heaters are perfect for smaller rooms such as bedrooms, studies, conservatories and loft conversions.

Vent-Axia's Panel Heaters offer a wide range of heat outputs from 750W to 2000W and every model is available with or without a timer. Vent-Axia Panel Heaters look as good as they perform. Stylish and slim, they occupy minimal wall space and are finished in an attractive white finish.

Vent-Axia Panel Heaters are wall mounted and connected to the permanent electrical supply via a fused connection switched outlet. Vent-Axia Panel Heaters are supplied with mounting brackets and one metre of cable connected to the bottom right hand side of the unit.

Adjustable Thermostat

All Vent-Axia Panel Heaters have a built-in adjustable thermostat offering a full temperature range, including a frost protection setting of 5°C.

For maximum safety there is a thermal cut-out on all models to prevent overheating should the outlet grille be accidentally covered.

Specification

Stock Ref	Model	Output	Weight
		kW	kg
439034 / 439038	VAPH 075/T	0.75	6.2
439035 / 439039	VAPH 125/T	1.25	6.6
439036 / 439040	VAPH 150/T	1.5	6.6
439037 / 439041	VAPH 200/T	2	8.0

220-240V-50Hz. BEAB Approved.

Dimensions (mm)

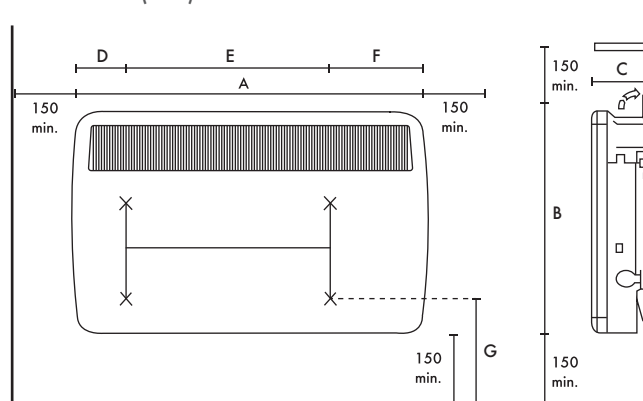

Stock Ref	A	B	C	D	E	F	G
439034 / 439038	620	430	108	118	288	214	255
439035 / 439039	690	430	108	118	358	214	255
439036 / 439040	690	430	108	118	358	214	255
439037 / 439041	860	430	108	118	528	214	255

Models

Manual and Timer versions available.

Model	Stock Ref
VAPH 075	439034
VAPH 075T	439038
VAPH 125	439035
VAPH 125T	439039
VAPH 150	439036
VAPH 150T	439040
VAPH 200	439037
VAPH 200T	439041

Optimax Plus Combination Storage Heater

Features & Benefits

- Optimised charge period offers 15% energy saving
- Reduced installation times
- Conveniently mounted controls
- Range of three heat outputs
- Colour RAL 9001
- IP20 rated
- BEAB approved



Comfort Heating

Vent-Axia Combination Storage Heaters take advantage of low tariff night-time electricity in the same way as our domestic storage heaters.

They combine the benefit of a domestic storage heater and a convector heater in one casing. The storage heater offers comfortable heat around the clock taking advantage of low tariff electricity.

The convector heater can be switched on at any time to offer additional heat when required, or used outside the normal heating season for instant heating.

Combination Heaters require a permanent power supply for immediate convection heating when required. The storage heater section has a separate off-peak supply.

Ease of Installation

Features such as snap-on feet, simple wall fixings and quick assembly mean that new installations or replacement of existing units are completed with minimum disruption. The cable entry is located at the back of the unit on the bottom right hand side.

All models incorporate an ambient thermostat which optimises the charge to suit room conditions, typically saving an additional 15% in energy costs.

Vent-Axia Combination Heaters are slim, compact and aesthetically pleasing. Their attractive neutral finish blends in with a variety of decors.

The controls are conveniently positioned on top of the heater for ease of use. Once the optimum settings are selected, no further adjustment is necessary. A separate convector heater On/Off switch is situated on the side of the casing together with a thermostat for temperature control.

Models

Combination Heaters

Model	Stock Ref
VACSH 12A	438919
VACSH 18A	438920
VACSH 24A	438921

Dimensions (mm)

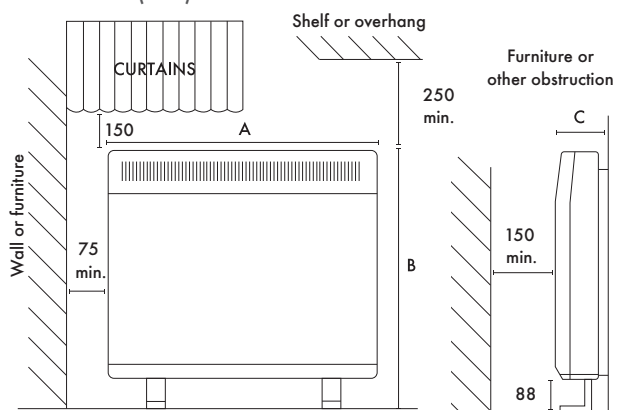

Stock Ref	A	B	C
438919	540	730	185
438920	765	730	185
438921	990	730	185

Specification

Stock Ref	Model	Input		Weight kg	Number of bricks
		kW	Output kW		
438919	VACSH 12A	1.70	1	79	8
438920	VACSH 18A	2.55	1.5	116	12
438921	VACSH 24A	3.40	2	152	16

220-240V-50Hz. BEAB Approved.

Optimax Plus Storage Heater

Features & Benefits

- Perfect for offices and homes
- Optimised charge period offers 15% energy saving
- Reduced installation times
- Conveniently mounted controls
- Range of four heat outputs
- Colour RAL 9001
- IP20 rated



Comfort Heating

Vent-Axia Storage Heaters are often an economic alternative for new build or in existing properties, particularly where no other fuel source is available.

Vent-Axia Storage Heaters are simple to install, economical to run and virtually maintenance free. Ideal for use in living rooms, hallways and landings.

The range can be installed in bathrooms outside Zone 2, provided that the installation complies with IEE regulations.

Vent-Axia Storage Heaters offer comfortable warmth around the clock taking advantage of low-tariff electricity.

Ease of Installation

Simple to install wall fixings and quick assembly mean that new installations or replacement of existing units are completed with minimum disruption. The cable entry is located at the back of the unit on the bottom right hand side.

The automatic Optimax Plus storage heaters incorporate an ambient thermostat which optimises the charge to suit room conditions, typically saving an additional 15% in energy costs.

Vent-Axia storage heaters are slim, compact and aesthetically pleasing. Their attractive neutral finish blends in with furnishings.

The controls are conveniently positioned on top of the storage heater for ease of use. Once the optimum settings are selected, no further adjustment is necessary.

Models

Model	Stock Ref
VASH 6A	438673
VASH 12A	439359

VASH 18A	439360
VASH 24A	439361

Dimensions (mm)

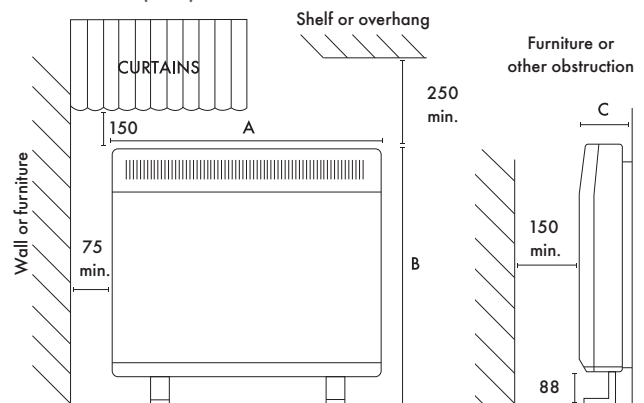

Stock Ref	A	B	C
438673	332	700	170
439359	560	700	170
439360	788	700	170
439361	1016	700	170

Specification

Stock Ref	Model	Input kW	Weight kg	Number of bricks
438673	VASH 6A	0.85	41	4
439359	VASH 12A	1.70	77	8
439360	VASH 18A	2.55	110	12
439361	VASH 24A	3.40	145	16

220-240V-50Hz.

Plinth Heaters

Features & Benefits

- Ideal for where wall space is at a premium
- Finishes: Stainless steel, Brown or White
- Optional thermostatic control 5-30°C
- Can be used with remote switch VARSU 436494
- Two heat settings 1kW & 2kW
- Fan only mode



Vent-Axia Plinth Heaters are designed for use in kitchens and bedrooms. They fit neatly into most types of fitted furniture, fascias, display units and false walls.

When installed in a corner with an adjacent cupboard to the right, a distance of at least 150mm must be maintained between the right hand end of the heater and the front of the adjacent cupboard door.

Vent-Axia Plinth Heaters are supplied with 1.5m of 1mm² 3 core cable, terminating on the right hand side of the unit.

Models

Thermostatic Models



Model	Stock Ref
VAPL2TC-S	459115
VAPL2TC-W	459116
VAPL2TC-B	459117

Dimensions (mm)

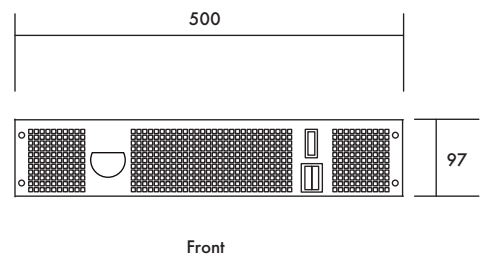
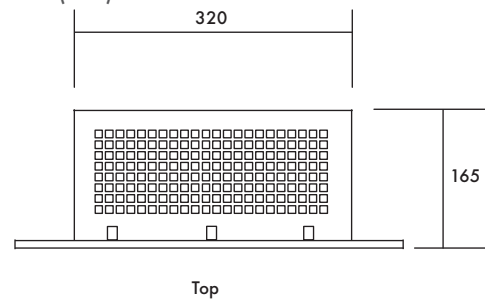

Weight: 3kg
Cut Out (WxH): 470x85mm

Warm Air Curtains

Features & Benefits

- Integral switching for faster installation
- Three heat settings and fan only mode
- Models to suit single and double doorways
- Suitable for use as a high level fan heater



Vent-Axia Warmair Curtains provide a heated downflow of warm air in doorways of commercial premises such as shops, offices and schools.

The robust outer case is made from painted steel with an off white epoxy finish. Accommodating varying door widths is easily achieved by installing Warmair units 'side by side'.

Vent-Axia Warmair Curtains are supplied with 0.75m of 3 core cable, and mounting brackets.

Three Warmair models are available offering heat outputs plus fan only setting:

Warmair 3 - 3 kW, 2 kW, 1 kW

Warmair 4.5 - 4.5 kW, 3 kW, 1.5 kW

Warmair 6 - 6kW, 4 kW, 2 kW

Models

Warm Air Curtains

Model	Stock Ref
Warmair 3	456343
Warmair 4.5	456344
Warmair 6	456345



Remote Switch

Remote Switch unit to control Warmair units. Switch allows for fan only & three heat settings.

Model	Stock Ref
VARSU	436494

Specification

Model	Rating	Dimensions mm			Weight
	kW	W	H	D	kg
Warmair 3	3.0	650	103	210	6.1
Warmair 4.5	4.5	650	103	210	6.5
Warmair 6	6.0	900	103	210	8.7

220-240V-50Hz. BEAB Approved.

Convector Heater

Features & Benefits

- Silent operation
- Ideal for use where occasional heating is required
- Three heat outputs
- Thermostatic control
- Safety thermal cutout
- BEAB Approval

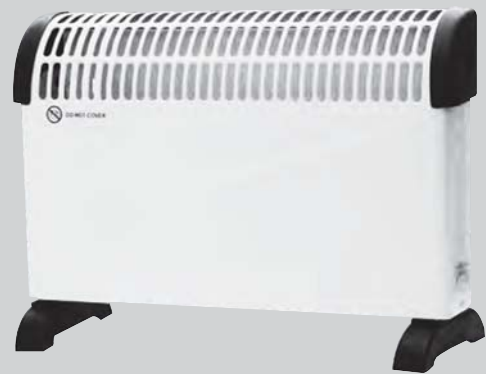

The Vent-Axia Convector Heater is ideal for use in any domestic or commercial room where extra or occasional heating is required. The heater is suitable for use in the home, offices, shops and workshops, but is not recommended for use in bathrooms.

The unit offers three heat outputs; 0.75kW, 1.25kW and 2kW, and is supplied with a thermostatic control.

The Vent-Axia Convector Heater is lightweight, portable and is supplied with a cable and plug. Stylish and versatile, the heater may be wall mounted or installed as a floor standing unit using the feet included. This gives the benefit of moving the heater to an area where you want, when you want.

For maximum safety the heater includes a thermal cut-out feature to prevent overheating.

Model

Convactor Heater

Model

VACH2-TC

Stock Ref

426250

Specification

Model	Rating	Dimensions mm			Weight
	kW	W	H	D	kg
VACH2TC	2	530	370	110	2.3

220-240V-50Hz. BEAB Approved

Portable Fan Heater

Features & Benefits

- Silent operation
- Ideal for use where occasional heating is required
- Two heat settings
- Thermostatic control
- Safety thermal cutout
- Fan only mode for summer cooling



The Vent-Axia Portable Fan Heater is a floor standing heater with three settings, fan only, 1kW and 2kW outputs. Variable thermostat. The unit comes complete with a 13amp plug.

Model

Portable Fan Heater



Model

VAFH2TC

Stock Ref

426715

Specification

Model	Rating	Dimensions mm			Weight
	kW	W	H	D	kg
VAFH2TC	2	265	130	275	1.5

Accessories & Controllers



For ventilation systems to be truly efficient it is important for them to operate only when needed. Our range of Sentinel demand ventilation systems along with our controls and sensors help respond to the exact ventilation requirements of a room at any one time. Providing airflow only when it is required and at the level that it is required ensures that only the energy that is needed is used; no more, no less.

Approved Document L now recognises the value that controls can offer and you will find Vent-Axia offer a range of solutions to ensure that you can maximise the benefit of automation wherever you chose to use it.

Vent-Axia

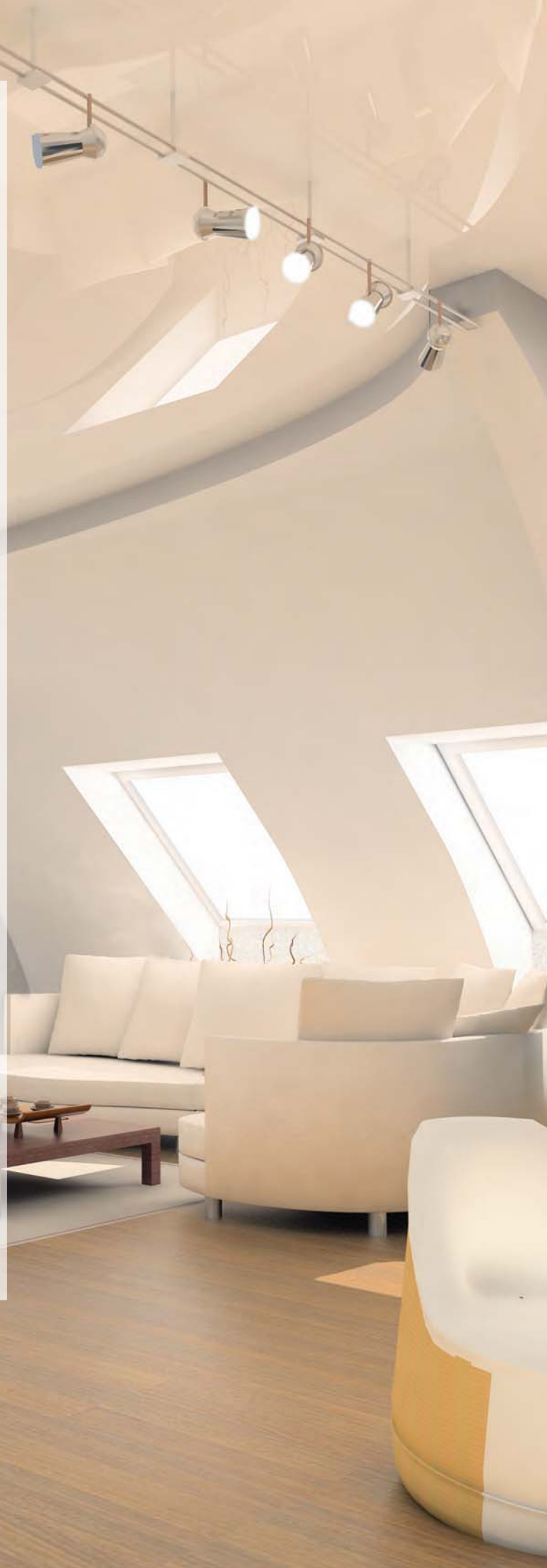



Controllers and Sensors

250-259



Ventilation Accessories

260-267

Controllers & Sensors



Ecotronic Controller Surface Mounting

An electronic controller for use with all Traditional T-Series and Standard Range models to give extract/intake and speed variation. For groups of units of any one size up to a total of 400 Watts. Do not mix T-Series with Standard Range. Where a controller is used with T-Series, 5-core flexible cord is required.

- 'E' running position for optimum efficiency.
- Finger-tip sliders.
- Infinitely variable speed control.
- Double pole On/Off switching.
- Extract/intake airflow direction.
- Neon indicator.
- Sensor mode for use with suitable electromechanical switches, eg. ThermoSwitch, HumidiSwitch to give automatic fan operation.
- Adjustable minimum speed setting.
- Knockouts for recessed wiring.
- Ambient operating temperature range 0°C to +40°C.
- Dimensions: 86 x 156 x 53mm (H x W x D).
- Supply voltage 220-240V/1/50Hz.
- Maximum load: Ecotronic - 400 Watts.
- Designed to meet IP20.
- BEAB Approved.

Stock Ref
W362320

Flush Fitting Box
Stock Ref
400144



T-Series® Controller Surface Mounting

A single unit controller for use with all Traditional T-Series ventilating units. With knockouts for recessed wiring. Where a controller is used with T-Series, 5-core flexible cord is required.

- 3-speed operation. High, medium or low.
- Finger-tip sliders.
- Double pole On/Off switching.
- Extract/intake airflow direction.
- Sensor mode for use with suitable electromechanical switches, eg. ThermoSwitch, HumidiSwitch to give automatic fan operation.
- Unique shutter open/ fan Off setting.
- Neon indicator.
- Knockouts for recessed wiring.
- Ambient operating temperature range 0°C to +40°C.
- Dimensions: 86 x 156 x 53mm (H x W x D).
- Supply voltage 220-240V/1/50Hz.
- Designed to meet IP20.
- BEAB approved.

Stock Ref
W361119

Flush Fitting Box
Stock Ref
400144



TimeSpan® Controller

Adjustable timer with overrun facility for fans ventilating WCs and other small rooms.

For use with any Vent-Axia fan within maximum rating below. The fan is switched On with the light and keeps running for a pre-set period after the light is switched Off.

- Fits to any single gang box.
- Adjustable time delay 5-25 minutes.
- Ambient operating temperature range 0°C to + 40°C.
- Maximum load 250W inductive.
- BEAB Approved.
- Dimensions: 87 x 87 x 33mm (H x W x D).
- Supply voltage 220-240V/1/50Hz.
- Will fit single gang box for surface mounting.

Stock Ref
563519

Surface Mounting Box
A surface mounting back box is available.
Stock Ref
410020

Registered design numbers: 1 030 207 Surface Mounting Controller, 1 030 208 Flush Fitting Controller. Patented Remote Speed Control Circuit. European Patent number EP 0180311.

Manufacturers of some fluorescent/low energy lighting systems indicate that these can interfere with other electronic/timing circuits. For reliable operation of these circuits we recommend therefore that a tungsten filament light is used.



Air Quality Sensor

Automatically reacts to the depletion of air quality, sensing unpleasant smells and toilet odours to regulate mechanically ventilated areas such as cinemas, pubs, clubs, restaurants, kitchens, toilets and conference rooms. This is not a CO₂ sensor.

The sensor switches the fan On when the air quality declines below an adjustable preset level. This is registered by the ceramic sensing head which is self-cleaning, a process which occurs every time the unit is triggered. When the atmosphere has returned to normal, the fan will continue to run for a pre-set period (adjustable between 1-25 minutes) and then switch Off.

The air quality sensor should not be used for the detection of combustible gases and is not designed for use as a smoke detector in an alarm system.

For use with various Vent-Axia fans within maximum rating below.

The Air Quality Sensor is also able to switch between trickle and boost speed on the appropriate ventilation units.

- Ambient operating temperature range 0°C to +50°C.
- Dimensions:
87 x 157 x 47mm (H x W x D).
- Maximum switched load:
2A inductive at 240V.
- Sensor consumption: 25mA at 240V.
- Supply voltage 240V/1/50Hz.

Stock Ref

563506



Electronic 1.5A Controller

Surface mounted, providing infinitely variable speed control and features an On/Off/sensor slider with neon indicator. There is an adjustable minimum speed setting. The controller is radio suppressed to BS EN 55014 and electrical connections for use with suitable external sensors are provided.

86 x 156 x 53mm (H x W x D).

Hole for wall box:

80x150x150mm (H x W x D).

Stock Ref

W300310

For flush fitting a metal wall box accessory is available.

Flush fitting box

Stock Ref

400144

Controllers & Sensors



Ambient Response Humidity Sensor

A self programming electronic On/Off wall mounted humidity sensor which reacts to any rapid increase in humidity and temperature by switching a Vent-Axia fan 'On' for rapid removal of moisture laden air in domestic bathrooms and kitchens. Can be wired into controller 'Auto' mode connections. Night time relative humidity increment setback feature suppresses nuisance tripping when the humidity level gradually rises as the temperature falls.

- Pullcord override and neon indicator.
- Changeover relay switch.
- Operating range: 30%-90%RH.
- Ambient operating temperature +5°C to +40°C.
- Dimensions: 87 x 87 x 33mm (H x W x D).
- Will fit single gang box for surface mounting.

Stock Ref

563550 240VAC 50Hz

European Patent No: 2298057

Surface Mounting Box

A surface mounting back box is available.

Stock Ref

410020



Ambient Response SELV 12 Humidity Sensor

12V Safety Extra Low Voltage version for use with VA100 SELV, Solo SELV, LuminAir SELV and HR100 SELV range.

The latest self programming electronic On/Off wall mounted humidity sensor which reacts to any rapid increase in humidity and temperature by switching a Vent-Axia fan 'On' for rapid removal of moisture laden air in domestic bathrooms and kitchens. Can be wired into controller 'Auto' mode connections. Night time relative humidity increment setback feature suppresses nuisance tripping when the humidity level gradually rises as the temperature falls.

- Pullcord override and neon indicator.
- Changeover relay switch.
- Operating range: 30%-90%RH.
- Ambient operating temperature +5°C to +40°C.
- Dimensions: 87 x 87 x 33mm (H x W x D).
- Will fit single gang box for surface mounting.

Stock Ref

563551 12VAC 50Hz

Surface Mounting Box

A surface mounting back box is available.

Stock Ref

410020



Lo-Carbon Ambient Response Humidity Sensor

Designed specifically for the Lo-Carbon product range. This self programming electronic On/Off wall mounted humidity sensor reacts to any rapid increase in humidity and temperature by switching a Vent-Axia fan 'On' for rapid removal of moisture laden air in domestic bathrooms and kitchens. Night time relative humidity increment setback feature suppresses nuisance tripping when the humidity level gradually rises as the temperature falls.

- Pullcord override and neon indicator.
- Changeover relay switch.
- Operating range: 30%-90%RH.
- Ambient operating temperature +5°C to +40°C.
- Dimensions: 87 x 87 x 33mm (H x W x D).
- Will fit single gang box for surface mounting.

Stock Ref

563552 12VDC

Surface Mounting Box

A surface mounting back box is available.

Stock Ref

410020

All of these Sensors can be wired for either On/Off or Trickle/Boost operation.

Manufacturers of some fluorescent/low energy lighting systems indicate that these can interfere with other electronic/timing circuits. For reliable operation of these circuits we recommend therefore that a tungsten filament light is used.



Ecotronic Humidity Sensor Surface Mounting

An adjustable set point, solid state On/Off sensor. A pullcord provides manual override, indicated by lamp. Adjustable from 65 to 90% relative humidity. Can be wired into controller 'Auto' mode connections. Incorporates changeover switch to select low/high speed.

- Setting range 65% - 90%RH.
- Maximum switching load 1 Amp inductive.
- Pullcord override indicated by lamp.
- Ambient operating temperature 0°C to +40°C.
- Dimensions: 87 x 87 x 33mm. (H x W x D).
- Supply voltage 220-240V/1/50Hz.

Stock Ref
563532

Surface Mounting Box

A surface mounting back box is available.

Stock Ref
410020



Ecotronic® SELV 12 Humidity Sensor

12V Safety Extra Low Voltage version for use with VA100 SELV, Solo SELV, and LuminAir SELV range. Incorporates changeover switch to select low/high speed.

Although suitable for siting within reach of a shower or bath we recommend this model is located out of the spray zone of a bath or shower.

- Setting range 65% - 90%RH.
- Maximum switching load 5.6A @ 12V AC.
- Pullcord override indicated by lamp.
- Ambient operating temperature 0°C to +40°C.
- Dimensions: 87 x 87 x 33mm (H x W x D).
- Supply voltage 12V AC.

Stock Ref
563531

Surface Mounting Box

A surface mounting back box is available.

Stock Ref
410020



Vent-Axia HumidiSwitch

Operates Vent-Axia ventilating units on either a rise or a fall in humidity to control the damaging effects of condensation.

- Concealed adjustment.
- Setting range 20% to 80% RH.
- Ambient operating temperature 0°C to +50°C.
- Dimensions: 82 x 132 x 40mm (H x W x D).
- Rating 2A (1A inductive).
- Switching range 120-240V.
- Designed for use with controllers with 'Auto' mode facility.
- Single pole changeover contacts.

Stock Ref
563501

The Ecotronic and Ecotronic SELV 12 Sensor can be wired for either On/Off or Trickle/Boost operation.

Controllers & Sensors



7 Day TimeSwitch

For applications where regular switching is required at fixed periods or at different times on different days of the week, eg: offices, shops, pubs and restaurants.

The 7-day TimeSwitch gives twelve On or Off positions per day and can be set for 7 days. The cycle will repeat until changed.

- Analogue clock display and integral time switches for ease of setting.
- Manual override.
- Removable clear plastic cover protects TimeSwitch face.
- Volt free changeover contacts.
- Time base: 7 days.
- Shortest switching time: 2 hours.
- Maximum load: 16amp resistive (8amp inductive).
- Ambient operating temperature range -20°C to +85°C.
- Dimensions: 104 x 74 x 52mm (H x W x D).
- Supply voltage 220-240V/1/50Hz.

Stock Ref
563515



Vent-Axia ThermoSwitch

Automatically switches On fans on either a rise or fall in air temperature. The ThermoSwitch can be used with all Vent-Axia fans (via switch gear if appropriate) for the removal of warm air from buildings. It can also be used to switch On Hi-Line ceiling fans for summer cooling and to move high level warm air down to the working level during winter.

- Setting range: +6°C to +30°C.
- Two internal range limit/locking rings are included to allow setting within a limited temperature range or locking at a fixed t/o point.
- IP20 rated.
- Sealed sensing mechanism.
- Snap-action, single pole, changeover contacts.
- Mounting direct on surface only.
- Electrical connection to screw type terminals with rear or side cable entry.
- Dimensions: 80 x 104 x 36mm (H x W x D).
- Contact rating: 1.5 amp (inductive).
- 16 amps (resistive).
- Maximum voltage 250V.

Stock Ref
563502



Guardian Personnel Detector (PIR Sensor)

Suitable for controlling a range of Vent-Axia fans. Continuously monitors an area and activates when a moving body is detected.

- Supplied complete with wall mounting bracket.
- Adjustable timer overrun (5 seconds to 20 minutes).
- Supplied with lens to provide 15m (max) range, 200° detection area.
- Designed to meet IP55.
- Ambient operating temperature range -20°C to +50°C.
- Maximum load: 10 amp resistive (5 amp inductive).
- Suitable for use with fluorescent lighting up to 500W.
- Internal/External use.
- Supply voltage 220-240V/1/50Hz.

Stock Ref
563548

7 day Time Switch & Thermoswitch can be wired for either On/Off or Trickle/Boost operation.



Vent-Axia Visionex PIR

A wall or ceiling mounted movement detector for use with any domestic Vent-Axia mains voltage product. Also suitable for use with Vent-Axia T-Series controllers on 'Auto' setting and ITC controllers on sensor mode. Visionex PIR can be wired for either On/Off or Trickle/Boost operation.

- Fits any UK single gang mounting box.
- Adjustable timer overrun (5-25 minutes).
- Range of detection up to 10 metres.
- Designed to meet IP43.
- Ambient operating temperature range 0°C to +50°C.
- Maximum load: 2.5 amps/600W inductive. Not suitable for use with lighting.
- Internal use only.
- No switched live required for internal rooms and WCs.
- Double insulated.
- Volt-free contacts.
- Supply voltage 220-240V/1/50Hz.

Stock Ref
459623

Surface Mounting Box

A surface mounting back box is available.

Stock Ref
410020



Vent-Axia Visionex SELV 12 PIR

A wall or ceiling mounted movement detector for use with any domestic Vent-Axia SELV 12 product.

- Fits any UK single gang mounting box.
- Adjustable timer overrun (5-25 minutes).
- Range of detection up to 10 metres.
- Designed to meet IP43.
- Ambient operating temperature range 0°C to +50°C.
- Maximum load: 5.6 amps inductive @ 12V.
- Internal use only.
- No switched live required for internal rooms and WCs.
- Class III product.
- Volt-free contacts.
- Supply voltage 12V/1/50Hz.

Stock Ref
459624

Surface Mounting Box

A surface mounting back box is available.

Stock Ref
410020



3 Pole Isolator

Isolates Live, Neutral and Switched Live for integral timer fans. 6 amp, 3 pole isolator complying to the 3mm contact separation requirement for routine maintenance repair.

Stock Ref
563518

Surface Mounting Box

A surface mounting back box is available.

Stock Ref
410020

Controllers & Sensors



Fan Speed Adjuster

5 step speed adjuster for domestic kitchen extract fans, that can reduce the speed to 40% of its maximum performance.

91mm x 176mm x 85mm (WxHxD).

Stock Ref
458153



5 Step Auto Controller

Used in conjunction with speed controllable fans to provide 5 stepped speed without electronic motor 'hum'. Several fans can be connected to one transformer provided their combined load does not exceed the controller rating.

Single phase: 3.5 , 6.0 and 7.5amp. Rotary switch giving On/Off and five speeds.

Output voltages at 240V/1PH/50Hz 0, 90, 115, 140, 175, 240 volts.

Neon indicator. Enclosures are protected to IP54.

Dimensions	Stock Ref
230 x 168 x 118	10314103
230 x 168 x 118	10314105
284 x 240 x 132	10314107



Ventwise Controller

The award winning Ventwise controller has been designed to fully automate a ventilation system. The unit can be used on intermittent or continuous systems, switching a fan between Off and On or from trickle to boost speed. The controller saves energy by only switching when cooking is taking place or condensation is being generated. The current sensor detects when the power supply to an oven or hob is switched on. The temperature sensor detects the rise in temperature in the hot feed to a bath or shower. Suitable for 240V single phase, the Ventwise is capable of switching 2 amps or 500 Watts. Ideal for student accommodation, social and sheltered housing, the Ventwise maintains indoor air quality without the need for manual switching.

160mm x 85mm x 45mm (WxHxD).

Controller 3 sensor inputs

Stock Ref
435960

Controller 6 sensor inputs

Stock Ref
446409

Current Sensors

6m cable
Stock Ref
435956

12m cable

Stock Ref
435957

Temperature Sensors

6m cable
Stock Ref
435958

12m cable

Stock Ref
435959



Remote Delay Timer

A remote delay timer for use with all domestic products gives the option of offering a 2 minute delay before the fan starts. Once the fan has started the overrun timer is adjustable between 5-25 minutes.

Stock Ref
457986

Surface Mounting Box

A surface mounting back box is available.

Stock Ref
410020



Isolator Relay Controller

Allows fan unit to be isolated from other mains circuit when used with TIM2, Trickle/boost switch or light switch control.

Stock Ref
442030

Surface Mounting Box

A surface mounting back box is available.

Stock Ref
410020



150VA Transformer

Surface Mounting Transformer with six voltage selections for trickle settings to match dwelling volume. Provides Boost/Trickle ventilation when used with humidity sensors or a manual switch.

95 x 225 x 75mm (H x W x D).

Stock Ref
563538

Controllers & Sensors



Normal Boost Switch

A single gang switch to boost from high to low speeds on all heat recovery systems.
85 x 85 x 10mm (H x W x D).
Stock Ref
455213



VCON6

A double gang switch to boost from high to low speeds.
85 x 145 x 10mm (H x W x D).
Stock Ref
370356



Normal Boost Purge Switch

A single gang switch to operate between normal, boost and purge speeds.
85 x 85 x 10mm (H x W x D).
Stock Ref
5108454



Momentary Push Switch

Compatible with the Sentinel Kinetic range, the momentary switch boosts the unit for 30 minutes.
85 x 85 x 10mm (H x W x D).
Stock Ref
448929



LED Indicator

Compatible with the Sentinel Kinetic range, the LED indicator illuminates when the MVHR unit requires a filter check or if the unit has a fault. Supplied with 15 metres of cable.
85 x 85 x 10mm (H x W x D).
Stock Ref
448356



Normal Boost Switch - Stainless Steel

A single gang switch to operate normal/boost functions on MVHR systems. Brushed stainless steel finish.
90 x 90 x 18 (H x W x D).
Stock Ref
437320



Normal Boost Switch with Light Indicator

A single gang switch with LED illumination when in the Boost condition.
85 x 85 x 10mm (H x W x D).
Stock Ref
449060



2-Way Switch and Neons

A double gang switch to boost from high to low speeds on all heat recovery systems, incorporating neon lights to indicate speed settings. Suitable changeover relay required. 85 x 145 x 10mm (H x W x D).

Stock Ref
459746



3 Speed Controller

A three position rotary control which enables the unit to be manually switched from permanent trickle ventilation to either medium or boost speed.

85 x 85 x 25mm (H x W x D).

85 x 85 x 37mm (H x W x D): with rotary switch.

Stock Ref
563533



TIM2 Overrun Timer

The TIM2 is a remote mounting electronic overrun timer with a relay output. 2 Amp indication load maximum. Adjustable overrun 2-30 mins. Ideal for where fans are to be controlled in conjunction with a lighting circuit or activated by remote sensors.

76 x 76 x 41mm. (H x W x D).

Stock Ref
370346



HR500 Controller

Suitable for use with HR500 MVHR units. Surface mounting. On/Off remote sensor mode. Heat exchange, single fan extract or twin fan extract modes. Infinitely variable speed. Minimum speed setting.

Stock Ref
W14301010

Ventilation Accessories

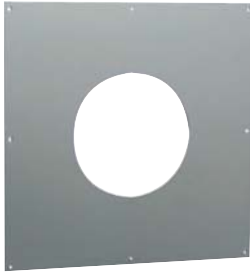

Fixing Plates

A single plate available in 300mm and 450mm square modular sizes for permanent fixing on walls or for use with other modular components.

Manufactured in high impact recyclable thermoplastic.

Unit Size	Stock Ref
6"	561136
7"	561137
9"	561139
12"	561142

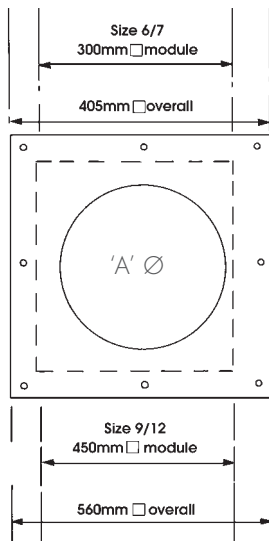

Vent-Axia fixing plate

Unit size	'A' Ø	Module Size
6"	184mm	300mm □
7"	222mm	300mm □
9"	260mm	450mm □
12"	337mm	450mm □



T-Series Adaptor Kits

Used for T-Series Window models in secondary double glazing, Roof models in secondary double glazing in exposed areas, Roof models through roofs and Darkroom models installed through either roof or walls. Adaptor kits allow units to be installed on two surfaces.

T-Series Adaptor kits consist of two Mounting plates with weather-tight seals and a set of fixing screws.

Unit Size	Stock Ref
6"	W561031
7"	W561032
9"	W561033
12"	W561034

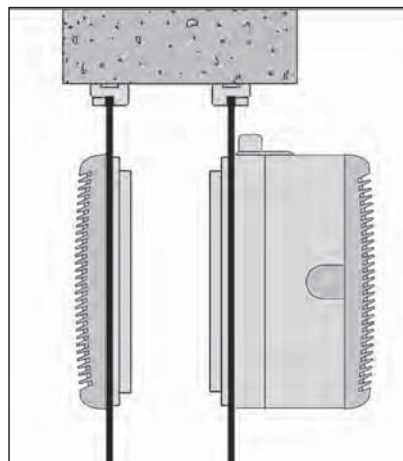

T-Series Extended Fixing Rod Sets

For use with T-Series Window and Roof models fitted through walls. Consists of a set of rods which are cut to suit the wall thickness.

Maximum thickness of wall 370mm.

Rod thread 3.5mm.

Unit Size	Stock Ref
6", 7" & 9"	568104
12"	568106

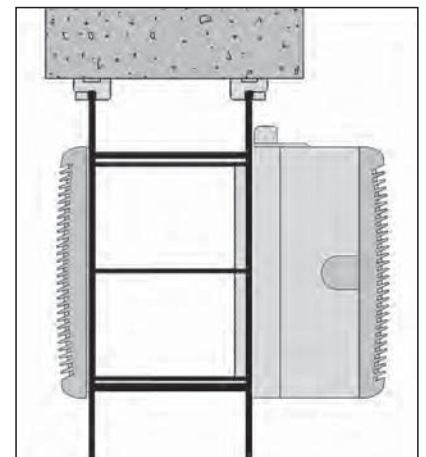



Wall Liner Section

Designed for T-Series units installed in walls thicker than 315mm, each liner section provides a maximum extension of 150mm. Wall liner section can also form a frame for Panel models in walls.

T-Series Wall Liners

Unit Size	Stock Ref
6"	460094
7"	460095
9"	460096
12"	460086



Mounting Boxes

A flanged sleeve in 300mm and 450mm square modular sizes used as an interconnecting sleeve between other modular accessories.

Mounting boxes will accept the depth of a unit and can be mounted in conjunction with a Fixing plate and Eggcrate grille for ventilation through ceilings.

Manufactured in flame retardant high impact recyclable thermoplastic.

Duct length 200mm.

Unit Size	Stock Ref
6"/7"	560236
9"/12"	560239

Unit Size	Mounting box modular size
6"/7"	300mm □
9"/12"	450mm □

Joining Bolt Set

Set of 8 nuts, bolts and washers.

Stock Ref
563000



Single Spigots

Single spigots in 300mm and 450mm square modular sizes. Used to connect Flexible ducting to Mounting boxes and other modular accessories or can be fixed directly to walls.

Manufactured in flame retardant high impact thermoplastic.

Unit Size	Nom Dia	Stock Ref
6"	175mm(B)	560637
6"/7"	225mm(B)	560639
7"	250mm(A)	560640
9"	300mm(A)	560642
9"	300mm(B)	566142
12"	400mm(B)	566146

Vent-Axia single spigot

Unit Size	'A' Ø	Module Size
6"	B 175mm	300mm
6"	B 225mm	300mm
7"	B 225mm	300mm
7"	A 250mm	300mm
9"	A 300mm	300mm
9"	B 300mm	450mm
12"	B 400mm	450mm

Ventilation Accessories



Multi-Spigot Plates

Available with 2, 3, 4 or 5 circular spigots of 100mm diameter. Multi-spigot plates are used in conjunction with 100mm Flexible ducting and other modular accessories to ventilate several small areas especially internal WCs. For use with Size 6 units only. Manufactured in flame retardant high impact recyclable thermoplastic.

Available in 300mm square modular size.

Description	Stock Ref
2-3-4 Spigots	560734
5 Spigots	560735



Cone Connectors

Used in conjunction with a Size 6 *Standard Range Panel model to reduce the outlet spigot (175mm Ø) to 100mm Ø flexible or rigid ducting.

The Cone connector is 280mm long and incorporates a splitter for improved performance. Manufactured in flame retardant, high impact thermoplastic. Colour: Grey.

Unit Size	Stock Ref
6"	560936

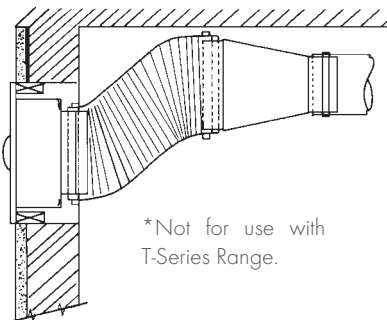

T-Series Direct Mount Spigots

Used to connect Flexible ducting directly to the inlet side of all T-Series models and the outlet side of T-Series Window models.

Manufactured in flame-retardant high impact recyclable thermoplastic.

Unit Size	Stock Ref
6" All models	560501
7" All models	560502
9" WW/RF	560503
9" WL/PL	560504
12" All models	560505

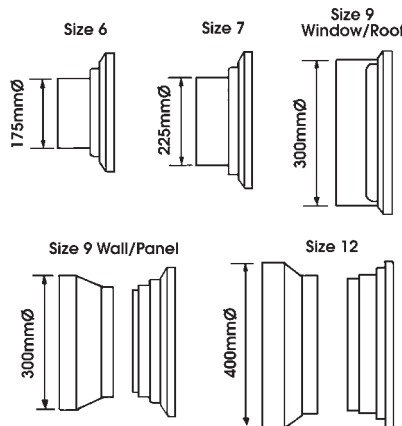

T-Series Darkroom Cowl Assembly

For use with all T-Series fans for Darkroom applications. Designed to give light protection.

Can also be used in other light sensitive areas such as medical, dental and veterinarian applications.

Unit Size	Stock Ref
6"	460585
7"	460586
9"	460587
12"	460588

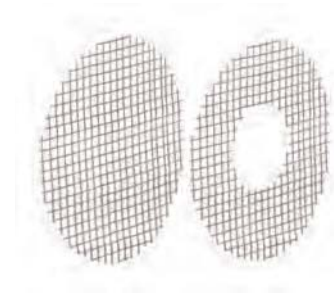

Standard Range Protective Grilles

Where Standard Range units are installed in low positions, finger guards provide extra protection to VDE, DIN 31001.

Standard Range internal grille (all models)

Unit Size	Stock Ref
6"	563106
7"	563107
9"	563109
12"	563112

Standard Range external grille (window models)

Unit Size	Stock Ref
6"	563406
7"	563407
9"	563409
12"	563412



Plenum Boxes

The Plenum box allows square grilles and diffusers to connect to circular duct. Each box size has a two diameter circular spigot for maximum versatility. The box is deep enough to accommodate both a double deflection grille and opposed blade damper.

Manufactured in flame retardant high impact recyclable thermoplastic.

Size	Stock Ref	Nom. Ø
200mm	560601	125/150mm
250mm	560602	150/175mm
300mm	560603	200/225mm
300mm	560604	250/300mm
450mm	560605	315/400mm

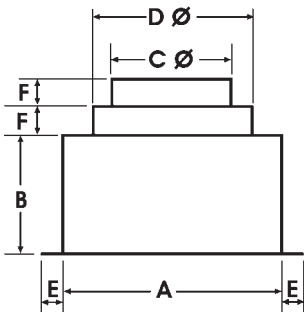

Dimensions (mm)

Stock Ref.	A	B	C Ø	D Ø	E	F
560601	200	130	125	150	25	25
560602	250	130	150	175	25	25
560603	300	130	200	225	25	25
560604	300	130	250	300	25	25
560605	450	130	315	400	25	25



Single Deflection Grilles

Single deflection grilles are suitable for either side wall or exposed duct applications.

The Single deflection grille has a single row of blades which permit up to 45° deflection of the air in one plane.

Satin silver finish.

Size 6/7 fits 300mm square modular size and size 9/12 fits 450mm square modular size.

Module size	Stock Ref
200mm sq	561370
250mm sq	561371
300mm sq	561372
450mm sq	561373



Double Deflection Grilles

Double deflection grilles are suitable for supply air for either side wall or exposed duct applications.

The Double deflection grille has two rows of blades set at 90° apart which permit up to 45° deflection of the air in two planes.

Satin silver finish.

Size 6/7 fits 300mm square modular size and size 9/12 fits 450mm square modular size.

Module size	Stock Ref
200mm sq	561380
250mm sq	561381
300mm sq	561382
450mm sq	561383

Ventilation Accessories



Eggcrate Grilles

Eggcrate grilles can be used for air replacement or air extract purposes.

Used underneath Roof plate assemblies with Roof models, underneath single spigots in ceilings, underneath mounting boxes and on the inside faces of walls that have units in fixed and removable wall plates on the outside of the wall.

Comprising a 13mm square by 13mm deep mesh eggcrate core housed in a frame which has a satin silver or white finish.

Size 6/7 fits 300mm square modular size and size 9/12 fits 450mm square modular size.

Size 6/7 - 785cm² free area
Size 9/12 - 1810cm² free area

200mm Sq - 340 cm²
250mm Sq - 530 cm²

Satin finish.
Module size **Stock Ref**
200mm sq **561303**
250mm sq **561305**
300mm sq **561301**
450mm sq **561302**

White finish.
Module size **Stock Ref**
125mm sq **560846**
200mm sq **560847**
250mm sq **560848**
300mm sq **560849**
450mm sq **560850**



Opposed Blade Dampers

Opposed blade dampers are used to regulate air flow through all Vent-Axia grilles and diffusers. Key operated.

This action ensures that the downstream airflow is non-directional when the damper is in the partially closed position. Opposed blade dampers have aluminium blades and the frame is left in natural mill finish.

Can be used in conjunction with Eggcrate, Single deflection and Double deflection grilles.

Size 6/7 fits 300mm square modular size and size 9/12 fits 450mm square modular size.

Module size **Stock Ref**
200mm sq **561341**
250mm sq **561342**
300mm sq **561343**
450mm sq **561344**



Filtered Inlet Grille

For ceiling, panel or glass mounting. Consists of a size 6 grille, washable filter, adaptor kit and a stepped spigot to suit 100, 125 or 150mm diameter ducting.

Grille size: 226mm x 220mm
Spigot depth: 100mm
Fixing hole diameter: 184mm

Stock Ref
W563536



4-Way Diffusers

Manufactured in polypropylene plastic. Four diffuser cassettes can be set for downward or 45° discharge in any of sixteen directional combinations.

Colour: Ivory

Neck Size	Stock Ref
225mm	10546230
300mm	10546300
350mm	10546350
400mm	10546400
450mm	10546450

500mm fits ceiling grid size 600mm
595mm overall diffuser size



Neck Adaptor

Used to connect Flexible ducting directly to 4-way diffusers. Integral volume control damper for duct sizes up to 300mm.

Diffuser	4-Way	
Duct Size	Neck Size	Stock Ref
150mm Ø	225mm	10547150
200mm Ø	225mm	10547200
250mm Ø	300mm	10547250
300mm Ø	350mm	10547300
400mm Ø	400mm	10547400
400mm Ø	450mm	10548400



Window/Wall/Ceiling Termination Sets

Used to terminate Flexible ducting at windows. Can be used with the Extended fixing rod set or Fixing plates for termination at walls. Used with Flexible ducting and Worm drive clips.

Consists of a Direct mount spigot, Adaptor kit, Window grille and all screws.

Unit Size	Spigot DiaØ	Stock Ref
6"	175mm	W560151
7"	225mm	W560152
9"	300mm	W560153
12"	400mm	W560154

Other sizes	Spigot DiaØ	Stock Ref
100/125/150mm		W10554150
200mm		W10554200
250mm		W10554250
315mm		W10554315

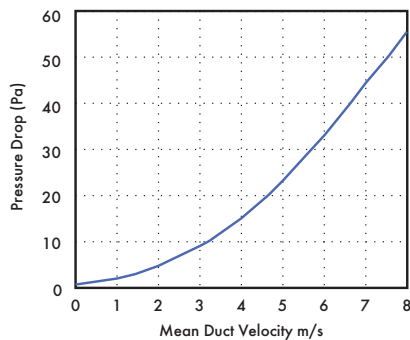

Air Replacement Non-Vision Grilles

Satin finish

Non-vision grilles consist of a single row of overlapping chevron vanes. Used as transfer grilles for doors or partitions, the overlapping vanes prevent through-vision.

Module size	Stock Ref
300mm sq	561311
450mm sq	561312

Black finish

In addition to preventing through-vision the black finish also limits light transference. Use two grilles back to back for darkroom applications.

Module size	Stock Ref
300mm sq	561321
450mm sq	561322



Fire Dampers

Available in 300mm and 450mm square modular sizes. For use with other modular accessories when a duct passes through a ceiling or wall requiring a damper to be fitted. 107mm deep.

Concertina type with 71°C fusible link, 2 hour rated.

Manufactured in stainless steel.

Size	Stock Ref
6/7"	561901
9/12"	561902



Roof Termination Sets

Used to terminate Flexible ducting at roofs. Consists of: Direct mount spigot, Adaptor kit, Roof cowl, Deflector and all screws. Can be used with Roof Plate Assemblies for installation on flat roofs.

T-series units

Size	Spigot Ø	Stock Ref
6"	175mm	560161
7"	225mm	560162
9"	300mm	560163
12"	400mm	560164

Vent-Axia roof termination

Diameter	Stock Ref
100/125/150mm	10555150
200mm	10555200
250mm	10555250
315mm	10555315

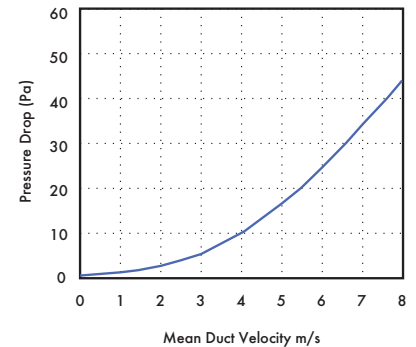

Ventilation Accessories



Air Replacement Non-Vision Door Grilles with Matching Flanges

Non-vision grilles consist of a single row of overlapping chevron vanes to prevent through-vision, supplied with matching flanges. The grille is fitted to one side of the door with the matching flange on the other side.

Suitable for door thicknesses of 19-49mm.

Available in Silver or Brown finish, in two sizes, 600 x 150 and 600 x 300mm.

Satin finish

Size	Stock Ref
600 x 150mm	561390
600 x 300mm	561391

Brown finish

Size	Stock Ref
600 x 150mm	560900
600 x 300mm	560901



Heavy Duty T-Series Wall Grilles

Tough aluminum construction for accessible public areas. Fits T-Series wall models in place of existing external grille. Finish T-Series grey.

Size	Stock Ref
6"	452725
7"	452726
9"	452727
12"	452728



External Louvres Mill

Weather resistant external louvres are suitable for air intake or discharge and for use with ducting on external walls.

The narrow blade construction has a 38mm pitch set at 45° with a depth of 41 mm and an integral rain lip.

Standard 32mm wide undrilled outer flanges in aluminium have fully welded mitre corners as standard.

Size 6/7 fits 300mm square modular size and size 9/12 fits 450mm square modular size.

Size 6/7 - 345cm² free area
Size 9/12 - 824cm² free area

Satin finish

Size	Stock Ref
225mm sq	561350
300mm sq	561351
400mm sq	561355
450mm sq	561352

Brown finish

Size	Stock Ref
225mm sq	560910
300mm sq	560911
400mm sq	560912
450mm sq	560913



Louvre Grilles

Louvre grilles can be used for air replacement, for extract purposes and as an external louvre. Available in four sizes, the assembly fits over rather than into the aperture making it especially useful where there are space restrictions within the duct.

Manufactured in thermoplastic. Choice of three colours: White, Brown and Grey.

Size 6	- 190cm ² free area
Size 7	- 335cm ² free area
Size 9	- 415cm ² free area
Size 12	- 705cm ² free area

Grille Dimensions (mm)

Size	w x h
6"	= 310 x 303
7"	= 352 x 345
9"	= 391 x 388
12"	= 470 x 467

The grilles and surrounds are moulded in ABS plastic to tone in with building materials, therefore an equivalent BS or RAL colour reference cannot be given.

Unit Size	Colour	Stock Ref
6"	Grey	W561431
6"	Brown	561411
6"	White	561421
7"	Grey	W561432
7"	Brown	561412
7"	White	561422
9"	Grey	W561433
9"	Brown	561413
9"	White	561423
12"	Grey	W561434
12"	Brown	561414
12"	White	561424



Roof Plate Assemblies

Vent-Axia roof plate assemblies are manufactured in high impact recyclable thermoplastic. They consist of a strong one piece moulded plate with extended sides to assist flashing and weather protection. A separate sub-frame is provided for permanent fixing to the roof kerb. The Vent-Axia Roof model is then fitted to the plate using a suitable sealing compound between the Cowl and plate, ensuring a weather-tight seal.

Size	Stock Ref
6"	560136
7"	560137
9"	560139
12"	560142

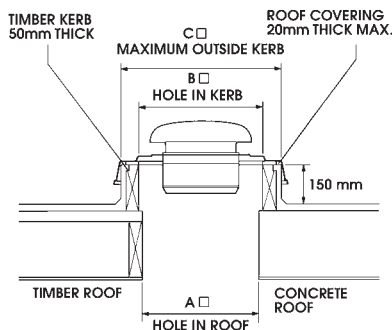

Size	A	B	C
6"	300mm	335mm	465mm
7"	300mm	335mm	465mm
9"	450mm	490mm	615mm
12"	450mm	490mm	615mm

In addition to the size 6, 7, 9 & 12 Roof Termination Sets, the Roof Plate Assemblies can also be used with the following Roof Terminations part numbers.

- 10555150 use size 6 Roof Plate Assembly
- 10555200 use size 7 Roof Plate Assembly
- 10555250 use size 9 Roof Plate Assembly
- 10555315 use size 12 Roof Plate Assembly



Joining Pieces

Used to join lengths of flexible ducting to give a long-lasting airtight connection.

Duct Size	Stock Ref
100mm Ø	561804
125mm Ø	561805
150mm Ø	561806
175mm Ø	561807
200mm Ø	561808
225mm Ø	561809
250mm Ø	561810
300mm Ø	561812
315mm Ø	561813
400mm Ø	561816



Worm Drive Clips

Stainless steel tightening band with quick-fix screwed ends for securing flexible ducting.

Max. Ø	Stock Ref
110mm	561704
215mm	561707
270mm	561710
380mm	561715
525mm	561720
660mm	561726



Standard Range Adaptor Kits

Used for Standard Range Window models in secondary double glazing, Roof models in secondary double glazing in exposed areas and Roof models through roofs.

Adaptor kits allow units to be installed on two surfaces and consist of an additional shroud and gasket, locking ring and seal. The shroud and gasket fit to the outside part of the unit, the locking ring and seal going to the inside part.

Fitting through holes in both Fixing Plates or glass, Vent-Axia's spigot and ring method of fixing allows simple installation separately to both parts.

Colour: Ivory.

Unit size	Stock Ref
6"	561011
7"	561012
9"	561013
12"	561014

Roof Units Industrial



Roof Units from Vent-Axia

The Roof Units™ name has long been associated with high quality ventilation products at affordable prices. With ERP 2015 compliance assured you can be certain of high quality ventilation products meeting the exacting demands of today.

The extensive Roof Units™ product range includes the Euroseries™ Axial plate, short cased & roof fans, as well as inline centrifugal extract fans and twin fans. When matched with the Roof Units™ and Vent-Axia ranges of controllers, flexible ducting and other accessories you can be certain of fulfilling the complete installation from one supplier.

Characterised by design excellence, Roof Units™ fans are purpose designed to deliver controllable outputs of up to 15m³/s, plus the right balance of airflow, pressure development, quietness and energy efficiency for every type of project.

The Euroseries™ range of Axial bladed fans cover plate, short cased & roof variants, all fully speed controllable, incorporating modern high efficiency external rotor motors with single piece die-cast aluminium rotor/impellers offering smoother running & giving longer reliable service life.

Vent-Axia®

	Energy Recovery Range (ERV)	270-273
	EuroSeries (ESP) Plate Mounted Axial Fans	274-281
	EuroSeries (ESC) Short Case Axial Fans	282-289
	EuroSeries® (ESR) Fan Assisted Roof Cowls	290-297
	NEW Quiet Pack (QP) In-Line Centrifugal Duct Fans	298-301
	NEW Quiet Pack (QPTW) In-Line Twin Fans	302-305
	Slimpack Fan (SLP) In-Line Centrifugal Duct Fans	306-309
	Slimpack Fan (SLPT) In-Line Twin Duct Fans	310-313
	EuroSeries (SDX) In-Line Centrifugal Duct Fans	314-317
	Speed Controllers Single & Three Phase	318-319
	Starter & Overloads	320
	Sonex Circular Sound Attenuators	321
	Pyrocheck (CVT) Intumescent Fire Dampers	322
	Unitex Roof Cowl System	323
	Unitex Wall Terminal (SA & QSA)	324

Energy Recovery Range

Features & Benefits

- 2 model sizes covering 500 to 1500m³/hr
- 90% efficient aluminium energy recovery cell
- High performance EC/DC motors
- Compact low profile unit (360mm high)
- Internal or External mounting as standard
- Robust aluminium cell construction
- Simple control functionality



Construction

The unit is manufactured with a frameless construction and incorporates single skinned Aluzinc panels with a highly thermal and acoustically efficient internal insulating foam. The unit is suitable for internal or external mounting as standard.

The unit is constructed with removable top and bottom access panels allowing full maintenance access.

The removable panels provide access to the following:

- ✓ Supply or extract fan
- ✓ Supply or extract filter (when fitted)
- ✓ Heat exchanger
- ✓ Frost heater (when fitted)

A separate side section access is provided for wiring termination and set-up/ commissioning. The user control interface therein is within a separate viewing and access panel allowing commissioning without the need to access to the wiring section. This controller can be demounted for remote installation if required.

Construction

The frameless single skinned construction, with Aluzinc panels internally lined with a 90kg/m³ high efficiency acoustic and thermally insulating foam (fire retardant to BS476 part 7 class 1 and part 6 class O), minimises noise and thermal breakout from the casing. Aluzinc construction allows for the units to be mounted either internally or externally as standard (IPX4). An optional inlet cowl is available for external applications if required.

The casing is designed to be as compact as possible for concealed false ceiling applications with access panels on both top and bottom as standard for ease of access and maintenance.

Performance and Sound

Extensively tested in accordance with BS 848 part 1 and 2, the published dB(A) figures are free field sound pressure levels with spherical propagation at reference level of 2×10^{-5} Pa. The inlet and outlet sound power level spectra figures are dB with a reference of 10^{-12} Watts.

Motor and impeller

All units contain a pair of Class 1 EC/DC external rotor motors with backward curved impellers carefully selected for maximum performance coupled with minimum sound and power consumption, fully compliant with the requirements for ERP 2015. The assembly is balanced to DIN ISO 1940 grade 6.3. Bearings are greased for life for maintenance free operation coupled with long service life for added peace of mind.

Electrical supply is 230V, 50Hz single phase.

Energy Recovery Cell

The ERV range includes an Aluminium counter flow plate heat exchanger offering higher efficiencies of up to 90%.

By utilising Aluminium heat exchangers the Vent-Axia ERV range of units can be installed in most environments including those with high humidity without the need to regularly maintain or replace the heat exchanger cell. The Aluminium cells are designed to be maintenance free (other than basic cleaning in situ) and to last the life of the unit.

Internal Unit Functionality

Flow Imbalance

The supply and extract flows on the standard unit can be offset by up to 20% to give an imbalanced flow as required.

Summer Bypass

The Standard ERV Hi-Box include as standard a Summer Bypass facility and integral controls to control its operation. The damper operates on both the Heat Recovery route and Bypass route enabling a full 100% bypass maximising the energy recovery benefits of free cooling when available.

Frost Protection

Integral to the standard unit is a 2 stage 2kW electric heater providing frost protection. The control for the inbuilt heaters is fully integrated and automatic ensuring the heat recovery cell does not freeze up under very low ambient conditions. The frost protection system will switch in each of the two stages as required when the ambient temperature falls below 0°C.

Condense Drain

All versions are fitted with a gravity condensation drain. An optional condensation drain pump is available for mounting in the condensation pipework external to the unit, includes float switch.

Filters

The ERV standard unit includes a G4 replaceable synthetic filter as standard.

Control

The Standard ERV unit comes complete with an integral controller providing manual variable speed control and the ability to control the summer bypass and frost protection functions. This allows the unit to be set to the customer requirements for continuous operation. The controller is fitted to the unit but can be remotely mounted on site if required. An integral time clock also provides for scheduling of the run for the unit. A boost facility can be manually selected via the unit controller. The controller LCD display shows the hours run and filter life information during operation and is fitted as standard to the unit although this can be remotely mounted on site.



Models

Stock Ref
ERV1000HIS
ERV1500HIS

Accessories

Model	Stock Ref
Filter G4 (ERV1000)	445851
Filter G4 (ERV1500)	447251
Weathercowl (ERV1000)	445832
Weathercowl (ERV1500)	446591

Dimensions (mm)

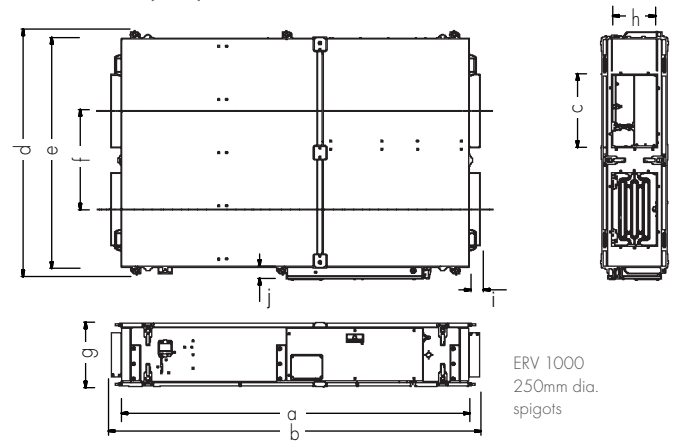

Model	A	B	C	D	E	F	G	H	I	J
ERV 1000	1800	1920	-	940	900	450	352	250Ø	60	65
ERV 1500	1900	2020	400	1290	1250	583	350	250	60	65

ERV Comparison Table

	Totus ² Range	ERV-HiBox Standard
Model / Stock Reference	All	ERV1000HIS ERV1500HIS
HR Cell 90%	✓	✓
Aluzinc Acoustic Casing	✓	✓
EC/DC Motors	✓	✓
Condensate Drain	Pumped	Gravity
Condensate Pump	✓	Option
Filter G4	✓	✓
Control Functionality	Sentinel Demand Ventilation control	Manual speed control and basic HR control
Bypass inc Actuator	✓	✓
Electric Frost Heater	✓	✓
Wall Controller	✓	✓
Isolator Switch	✓	✓
BMS Control	✓	x
External Damper Control	✓	x
Proportional Sensors Control	✓	x
Constant Pressure Control	✓	x
Weathercowl (ERV1000)	Option 445832	Option 445832
Weathercowl (ERV1500)	Option 446591	Option 446591

Note: Part numbers shown as option are available at extra cost and are supplied loose

Performance Guide

ERV1000HIS

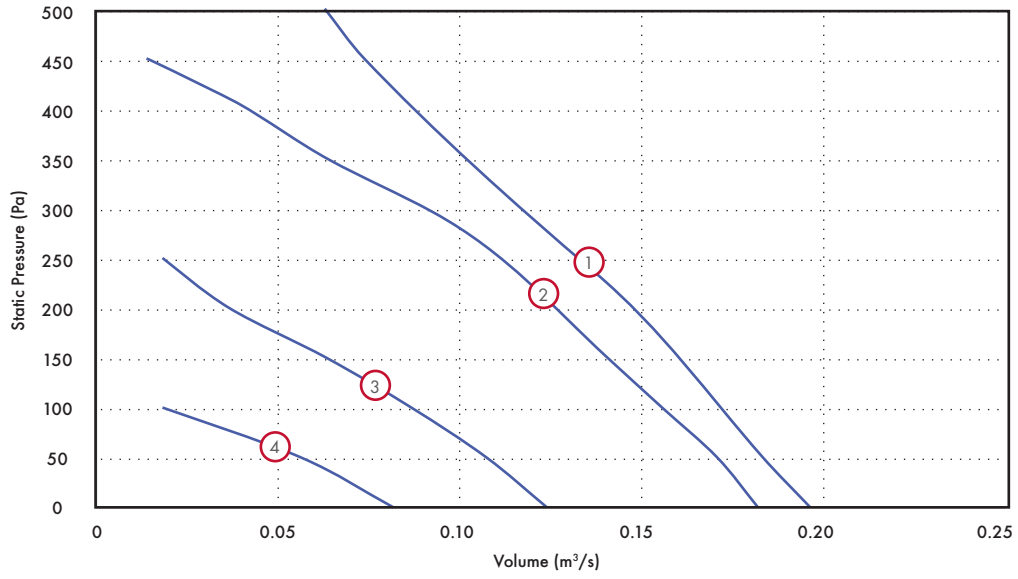

Stock Ref	Curve	Speed	Airflow, m ³ /s @ Pa											Supply	F.L.C Amps
			0	50	100	150	200	250	300	350	400	450	500		
ERV1000HIS	①	Max Supply	0.20	0.18	0.17	0.16	0.15	0.13	0.12	0.10	0.09	0.07	0.06	230V/1/50Hz	3.0
		SFP	1.71	1.84	1.98	2.14	2.32	2.53	2.86	3.28	3.81	4.71	5.67		
	②	Balanced 100%	0.18	0.17	0.16	0.14	0.13	0.11	0.09	0.07	0.04	0.01	2.5		
		SFP	1.44	1.55	1.70	1.87	2.02	2.27	2.58	3.00	3.60	3.66			
	③	Balanced 80%	0.12	0.11	0.09	0.06	0.04	0.02	1.0						
		SFP	0.89	1.03	1.21	1.51	2.04	2.51							
	④	Balanced 40%	0.08	0.06	0.02	0.5									
		SFP	0.57	0.80	1.64										

Sound Power Level Spectra dB (ref 10⁻¹² Watts)

Stock Ref	Speed	Test Mode	63	125	250	500	1K	2K	4K	8K	dB(A) @ 3m
ERV1000HIS	Max Supply	External	58	65	69	54	53	54	48	46	35
		Room side	55	59	55	50	49	53	37	36	
		Breakout	59	59	61	50	46	49	36	34	
	Balanced 85%	External	58	63	69	54	53	52	45	45	34
		Room side	53	58	55	46	48	50	34	34	
		Breakout	57	58	59	47	45	47	34	33	
	Balanced 65%	External	54	58	64	49	47	42	35	36	28
		Room side	49	53	53	39	40	38	26	29	
		Breakout	54	54	55	41	38	36	27	30	
	Balanced 35%	External	47	52	48	39	37	30	26	29	22
		Room side	48	48	38	33	31	27	22	28	
		Breakout	48	51	39	35	31	28	26	29	

Performance Guide

ERV1500HIS

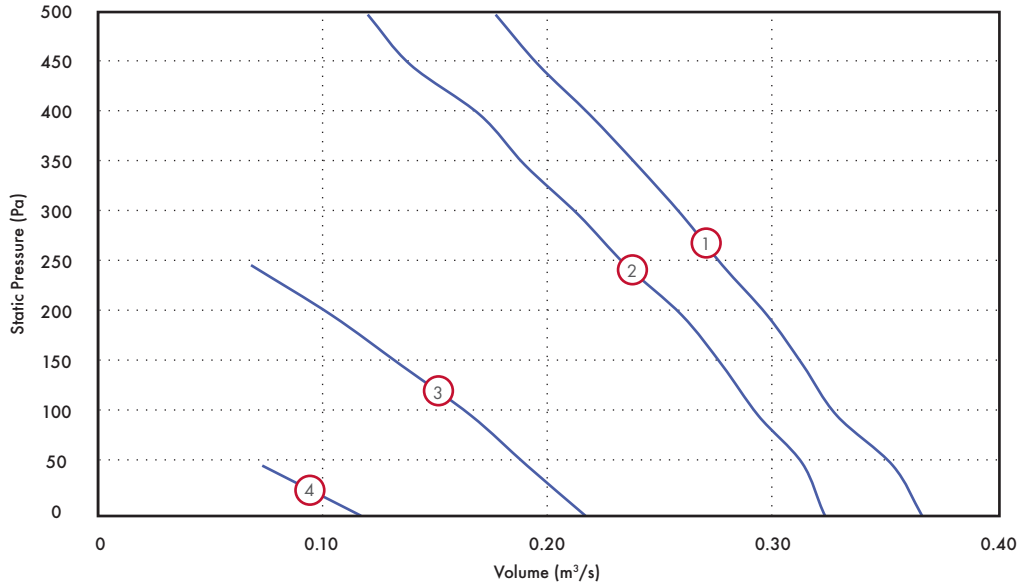

Stock Ref	Curve	Speed	Airflow, m ³ /s @ Pa											Supply	F.L.C Amps
			0	50	100	150	200	250	300	350	400	450	500		
ERV1500HIS	①	Max Supply	0.37	0.35	0.33	0.31	0.30	0.28	0.26	0.24	0.22	0.20	0.18	230V/1/50Hz	3.0
		SFP	1.71	1.77	1.91	2.01	2.10	2.26	2.40	2.58	2.79	3.05	3.31		
	②	Balanced 100%	0.32	0.31	0.29	0.28	0.26	0.24	0.21	0.19	0.17	0.14	0.12		2.5
		SFP	1.37	1.60	1.71	1.81	1.93	2.11	2.29	2.54	2.79	3.29	3.71		
	③	Balanced 80%	0.22	0.19	0.17	0.14	0.10	0.07							1.0
		SFP	0.91	1.04	1.19	1.43	1.78	2.56							
	④	Balanced 40%	0.12	0.07											0.5
		SFP	0.62	0.97											

Sound Power Level Spectra dB (ref 10⁻¹² Watts)

Stock Ref	Speed	Test Mode	63	125	250	500	1K	2K	4K	8K	dB(A) @ 3m
ERV1500HIS	Max Supply	External	66	70	75	60	57	52	50	45	41
		Room side	61	62	65	54	52	46	42	41	
		Breakout	65	68	69	54	49	45	40	40	
	Balanced 85%	External	64	68	72	57	53	49	45	42	37
		Room side	58	61	60	52	49	43	38	39	
		Breakout	62	66	64	51	46	43	38	39	
	Balanced 65%	External	59	64	57	46	45	40	35	32	29
		Room side	54	56	48	42	40	34	30	31	
		Breakout	59	62	50	41	38	34	29	30	
	Balanced 35%	External	58	53	46	37	37	29	25	29	22
		Room side	49	46	40	33	32	25	23	30	
		Breakout	52	52	41	32	30	27	25	31	

EuroSeries (ESP)

Features & Benefits

- Die cast aluminium impellers
- Fully speed controllable
- Air Volumes up to 13.89m³/s
- Sizes 315 to 1000 dia protected to IP54
- Operating Temperatures from -40°C up to +70°C Motor
- Insulation Class F
- Thermal overload for motor protection
- Reversible - Supply or Extract
- Tough epoxy paint finish
- Quality Assurance to BS EN ISO 9001:1994
- Performance tested to ISO 5801



The new range of EuroSeries ESP axial blade plate fans, feature a single shot die cast aluminium blade and external rotor motor design.

The EuroSeries ESP range is available in eleven sizes with the extract performances up to 13.89m³/s, with pressure characteristics of up to 300Pa. All units are designed for speed controllable.

Impellers

All sizes shall be supplied with cast aluminium impellers, ensuring performance when working against outdoor conditions and abrasive airflow. Where fans are reversible for Intake a -30% drop in performance can be expected.

Motors

External rotor motors are specially designed and styled for this range of fan. Ball bearings shall be greased for life. Rotors are dynamically balanced to ISO 1940. Sizes 315-1000mm, motors are protected to IP54, against dust and moisture complying with BS EN 60529:1992. They shall be ribbed aluminium body castings for efficient cooling. Motor insulation is Class 'F' (from -40°C to +70°C).

Electrical

Single phase 220-240V 50Hz. Capacitor start and run. Three phase 380-415V 50Hz. An IP54 terminal box shall be supplied with 20mm and PGII entry. All motors shall be fitted with thermal overload protection which should be wired into all controller circuits and into starter contactors. Models are available with either 2,4,6 or 8 pole motors.

Terminal Box

Terminal Box to IP54 as standard, protected against dust water from any angle allowing outside applications.

Performance

The fan performance, shall be in accordance with tests to BS848 Part 1 1980.

Sound Levels

Fan sound levels, measured in a reverberant chamber in accordance with BS848 Part 2 1985. Published dB(A) figures are free field sound pressure levels at 3m with spherical propagation at a reference level of 2×10^{-5} Pa (20 micro-Pascal). The sound power level spectra figures are dB with reference level of 10^{-12} Watts (1 pico-watt). To ensure minimum noise levels during speed control, an auto transformer speed control is recommended.

Accessories

A full range of accessories:

- Electronic Speed Controllers
- Auto Transformer Speed Controllers
- D.O.L. Starters & Overloads
- Discharge Guards
- Louvre Shutters

Dimensions (mm)

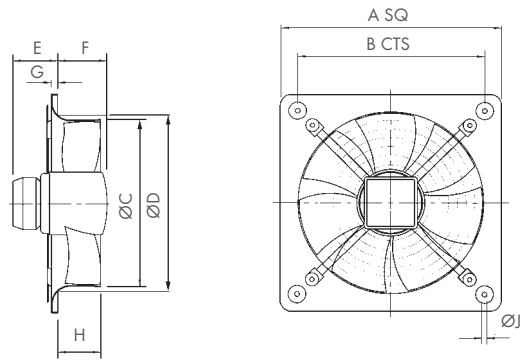

Dia	A	B	ØC	ØD	E	F	G	H	ØJ	Kg
250	370	320	256.5	264.5	84	80	6	80	9	3.4
315	430	380	320	328	84	84	19	70	9	6.3
355	485	435	367	372	86	97	21	75	9	7.3
400	540	490	412	420	93	100	12	88	9	10.2
450	575	535	463	480	86	139	14	96	11	15.8
500	655	615	517	528	84	141	16	104	11	17.3
560	725	675	568	589	81	142.5	16	119	11	24
630	805	750	643	664	82	142.5	20	130	11	45
710	850	810	720	763	37	176.5	20	150	14.5	31
800	970	910	804	869	34	244	17	193	14.5	38
1000	1170	1110	1009	1067	40	284	20	200	14.5	84

Performance Guide

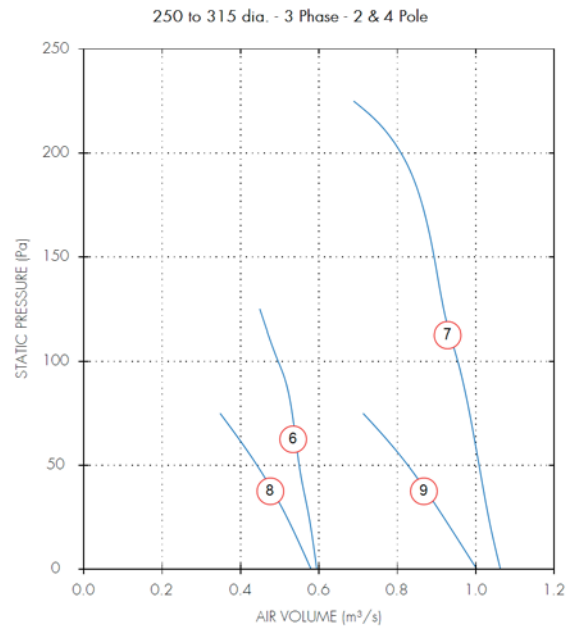
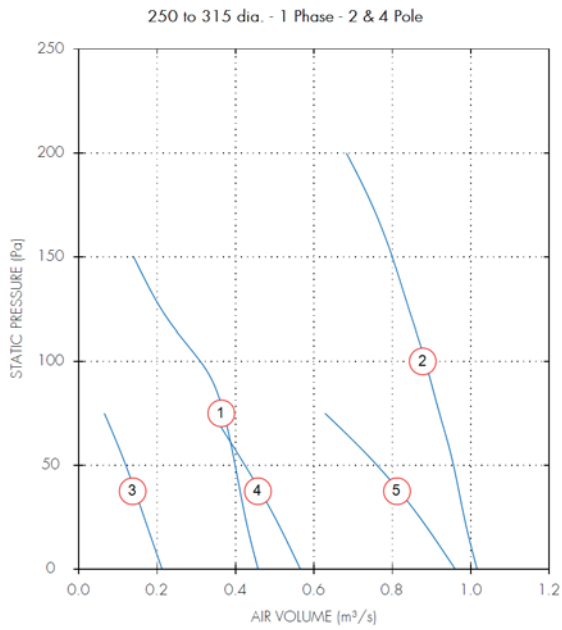

Dia.	Motor Phase	Stock Ref	Poles	r.p.m	IP Rating	Curve Ref.	0	50	m³/s @ Pa				Motor kW	S.C. Amps	F.L.C Amps	dBA @ 3m
									100	150	200					
250	1	ESP25012	2	2440	IP44	1	0.46	0.4	0.31	0.14		0.12	1.15	0.54	59	
315	1	ESP31512	2	2690	IP54	2	1.02	0.96	0.88	0.8	0.68	0.56	7.2	2.4	64	
250	1	ESP25014	4	1340	IP44	3	0.21	0.12				0.04	0.3	0.16	44	
315	1	ESP31514	4	1300	IP54	4	0.57	0.42				0.15	1.38	0.7	50	
355	1	ESP35514	4	1330	IP54	5	0.96	0.76				0.19	1.45	0.84	53	
250	3	ESP25032	2	2700	IP44	6	0.59	0.55	0.5			0.2	3.5	0.87	61	
315	3	ESP31532	2	2800	IP54	7	1.06	1.01	0.95	0.89	0.81	0.48	5	0.9	60	
315	3	ESP31534	4	1390	IP54	8	0.58	0.44				0.11	2.1	0.27	46	
355	3	ESP35534	4	1370	IP54	9	1	0.83				0.17	1.35	0.37	49	

For fans wired to reverse run, duty reduced by 30%. ESP25012, ESP31512 and ESP25014 not suitable for reverse airflow.

Sound Power Level Spectra dB (ref 10⁻¹² Watts)

Dia.	Motor Phase	Stock Ref	Poles	Spectrum	dB											
					63	125	250	500	1k	2k	4k	8k	dBA @ 3m			
250	1	ESP25012	2	Inlet	69	70	76	76	70	70	67	59	57			
250	1	ESP25012	2	Outlet	69	70	76	76	70	70	67	59	57			
315	1	ESP31512	2	Inlet	69	73	79	74	74	76	73	66	61			
315	1	ESP31512	2	Outlet	69	73	79	74	74	76	73	66	61			
250	1	ESP25014	4	Inlet	70	72	63	58	54	52	45	35	41			
250	1	ESP25014	4	Outlet	70	72	63	58	54	52	45	35	41			
315	1	ESP31514	4	Inlet	70	68	66	61	60	62	58	51	47			
315	1	ESP31514	4	Outlet	70	68	66	61	60	62	58	51	47			
355	1	ESP35514	4	Inlet	65	70	67	65	64	64	62	55	50			
355	1	ESP35514	4	Outlet	65	70	67	65	64	64	62	55	50			
250	3	ESP25032	2	Inlet	7	64	76	80	74	70	66	60	59			
250	3	ESP25032	2	Outlet	7	64	76	80	74	70	66	60	59			
315	3	ESP31532	2	Inlet	71	72	83	80	78	79	75	67	64			
315	3	ESP31532	2	Outlet	71	72	83	80	78	79	75	67	64			
315	3	ESP31534	4	Inlet	64	67	69	63	62	60	58	53	47			
315	3	ESP31534	4	Outlet	64	67	69	63	62	60	58	53	47			
355	3	ESP35534	4	Inlet	58	73	63	64	64	65	64	58	50			
355	3	ESP35534	4	Outlet	58	73	63	64	64	65	64	58	50			

Performance Guide

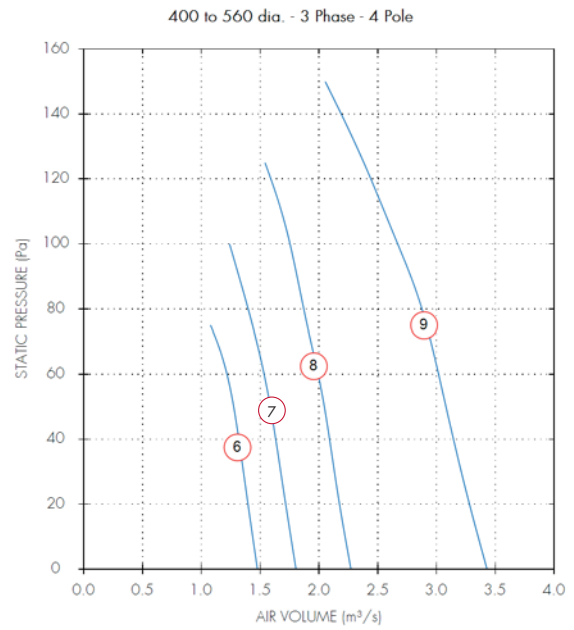
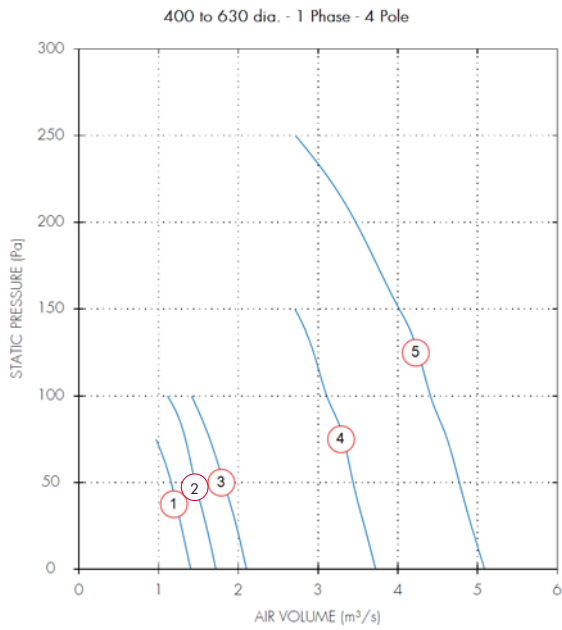

Dia.	Motor Phase	Stock Ref	Poles	r.p.m	IP Rating	Curve Ref.	m ³ /s @ Pa					Motor kW S.C.	Amps F.L.C	Amps	dBA @ 3m
							0	50	100	150	200				
400	1	ESP40014	4	1350	IP54	1	1.4	1.16				0.29	2.4	1.45	56
450	1	ESP45014	4	1370	IP54	2	1.72	1.46	1.11			0.36	3.6	1.6	61
500	1	ESP50014	4	1290	IP54	3	2.1	1.82	1.41			0.51	4.3	2.3	55
560	1	ESP56014	4	1320	IP54	4	3.72	3.44	3.11	2.71		1.35	9.3	6	63
630	1	ESP63014	4	1320	IP54	5	5.09	4.77	4.41	4.02	3.47	2.2	28	9.9	70
400	3	ESP40034	4	1350	IP54	6	1.48	1.27				0.26	2.1	0.56	51
450	3	ESP45034	4	1380	IP54	7	1.8	1.59	1.24			0.36	2.6	0.8	56
500	3	ESP50034	4	1380	IP54	8	2.27	2.05	1.75			0.55	4.2	1.05	58
560	3	ESP56034	4	1220	IP54	9	3.43	3.08	2.67	2.05		1.25	7.7	2.2	70

For fans wired to reverse run, duty reduced by 30%.

Sound Power Level Spectra dB (ref 10⁻¹² Watts)

Dia.	Motor Phase	Stock Ref	Poles	Spectrum	dB								dBA @ 3m
					63	125	250	500	1k	2k	4k	8k	
400	1	ESP40014	4	Inlet	70	72	67	66	65	65	64	56	51
400	1	ESP40014	4	Outlet	70	72	67	66	65	65	64	56	51
450	1	ESP45014	4	Inlet	69	76	73	72	70	71	70	62	57
450	1	ESP45014	4	Outlet	69	76	73	72	70	71	70	62	57
500	1	ESP50014	4	Inlet	65	75	69	70	70	71	69	62	56
500	1	ESP50014	4	Outlet	65	75	69	70	70	71	69	62	56
630	1	ESP63014	4	Inlet	82	86	79	79	80	78	75	70	64
630	1	ESP63014	4	Outlet	82	86	79	79	80	78	75	70	64
400	3	ESP40034	4	Inlet	62	73	65	65	67	69	67	60	53
400	3	ESP40034	4	Outlet	62	73	65	65	67	69	67	60	53
450	3	ESP45034	4	Inlet	65	82	75	76	73	72	69	62	58
450	3	ESP45034	4	Outlet	65	82	75	76	73	72	69	62	58
500	3	ESP50034	4	Inlet	67	71	69	72	70	71	68	61	56
500	3	ESP50034	4	Outlet	67	71	69	72	70	71	68	61	56
560	3	ESP56034	4	Inlet	85	79	77	76	76	75	72	66	61
560	3	ESP56034	4	Outlet	85	79	77	76	76	75	72	66	61

Performance Guide

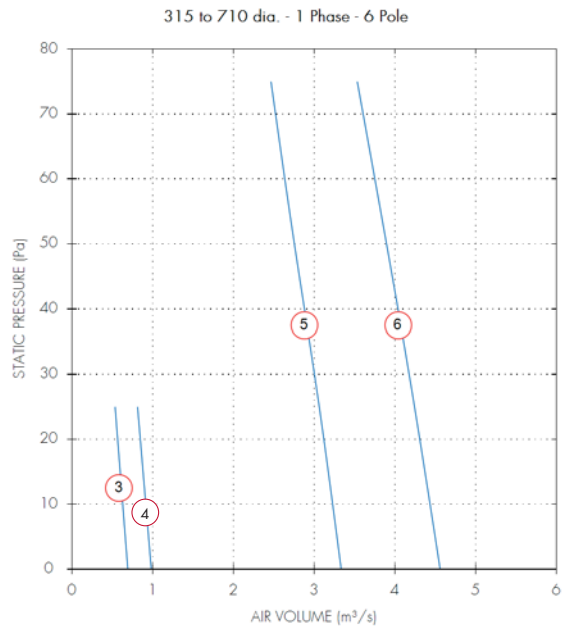
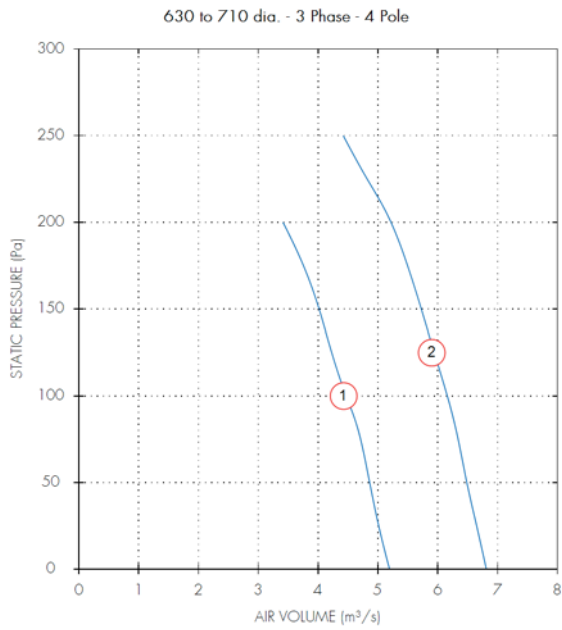

Dia.	Motor Phase	Stock Ref	Poles	r.p.m	IP Rating	Curve Ref.	m³/s @ Pa							Motor kW	S.C. Amps	F.L.C Amps	dBA @ 3m
							0	25	50	100	150	200	250				
630	3	ESP63034	4	1360	IP54	1	5.19	5.01	4.86	4.47	4.02	3.41	1.9	17	3.2	64	
710	3	ESP71034	4	1290	IP54	2	6.81	6.65	6.49	6.16	5.72	5.22	2.9	20	5.3	72	
355	1	ESP35516	6	950	IP54	3	0.69	0.53					0.09	1.2	0.46	44	
400	1	ESP40016	6	940	IP54	4	0.98	0.81					0.1	1.4	0.48	45	
630	1	ESP63016	6	880	IP54	5	3.33	3.06	2.75				0.6	5.3	2.7	57	
710	1	ESP71016	6	850	IP54	6	4.56	4.24	3.89				0.89	8	4.1	60	

For fans wired to reverse run, duty reduced by 30%.

Sound Power Level Spectra dB (ref 10⁻¹² Watts)

Dia.	Motor Phase	Stock Ref	Poles	Spectrum	dB								dBA @ 3m
					63	125	250	500	1k	2k	4k	8k	
630	3	ESP63034	4	Inlet	71	88	82	83	82	81	78	72	67
630	3	ESP63034	4	Outlet	71	88	82	83	82	81	78	72	67
710	3	ESP71034	4	Inlet	80	87	86	88	89	86	83	79	72
710	3	ESP71034	4	Outlet	80	87	86	88	89	86	83	79	72
355	1	ESP35516	6	Inlet	59	59	60	57	56	57	55	46	42
355	1	ESP35516	6	Outlet	59	59	60	57	56	57	55	46	42
400	1	ESP40016	6	Inlet	76	74	70	65	63	58	52	44	48
400	1	ESP40016	6	Outlet	76	74	70	65	63	58	52	44	48
630	1	ESP63016	6	Inlet	88	85	81	77	76	70	64	58	60
630	1	ESP63016	6	Outlet	88	85	81	77	76	70	64	58	60
710	1	ESP71016	6	Inlet	83	83	84	80	78	74	70	72	63
710	1	ESP71016	6	Outlet	83	83	84	80	78	74	70	72	63

Performance Guide

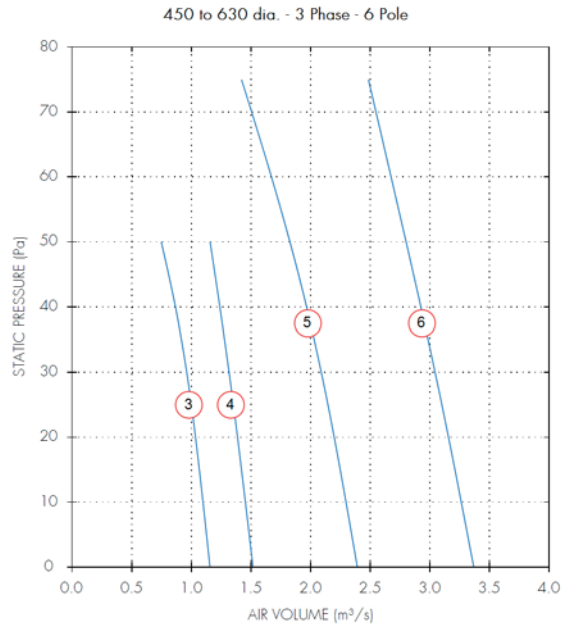
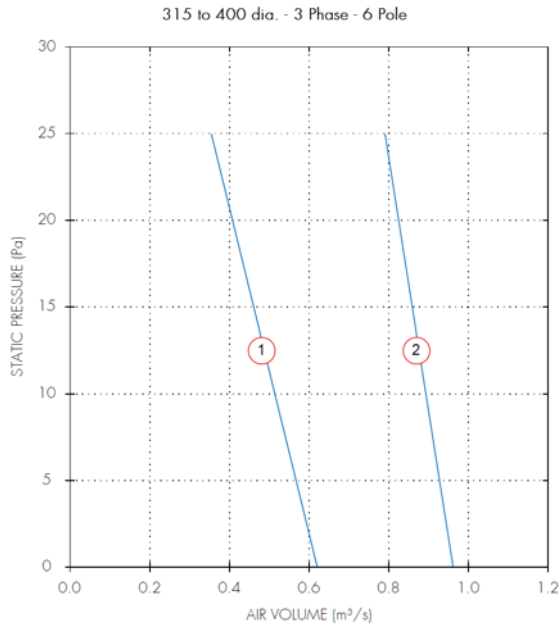

Dia.	Motor Phase	Stock Ref	Poles	r.p.m	IP Rating	Curve Ref.	m³/s @ Pa				Motor kW	S.C. Amps	F.L.C Amps	dBA @ 3m
							0	25	50	75				
355	3	ESP35536	6	910	IP54	1	0.62	0.35			0.09	0.5	0.25	45
400	3	ESP40036	6	920	IP54	2	0.96	0.79			0.11	0.9	0.28	50
450	3	ESP45036	6	890	IP54	3	1.16	1	0.75		0.12	1	0.28	51
500	3	ESP50036	6	900	IP54	4	1.52	1.35	1.16		0.23	1.5	0.56	56
560	3	ESP56036	6	860	IP54	5	2.39	2.14	1.83	1.42	0.36	1.75	0.74	56
630	3	ESP63036	6	890	IP54	6	3.37	3.1	2.8	2.48	0.59	3.6	1.3	59

For fans wired to reverse run, duty reduced by 30%.

Sound Power Level Spectra dB (ref 10⁻¹² Watts)

Dia.	Motor Phase	Stock Ref	Poles	Spectrum	dB								dBA @ 3m
					63	125	250	500	1k	2k	4k	8k	
355	3	ESP35536	6	Inlet	60	61	60	56	56	56	54	46	42
355	3	ESP35536	6	Outlet	60	61	60	56	56	56	54	46	42
400	3	ESP40036	6	Inlet	60	60	62	59	60	60	58	50	45
400	3	ESP40036	6	Outlet	60	60	62	59	60	60	58	50	45
450	3	ESP45036	6	Inlet	63	72	66	63	63	62	59	48	48
450	3	ESP45036	6	Outlet	63	72	66	63	63	62	59	48	48
500	3	ESP50036	6	Inlet	78	73	68	67	68	66	59	51	52
500	3	ESP50036	6	Outlet	78	73	68	67	68	66	59	51	52
560	3	ESP56036	6	Inlet	67	72	72	68	68	68	65	57	53
560	3	ESP56036	6	Outlet	67	72	72	68	68	68	65	57	53
630	3	ESP63036	6	Inlet	67	78	76	74	73	72	77	59	60
630	3	ESP63036	6	Outlet	67	78	76	74	73	72	77	59	60

Performance Guide

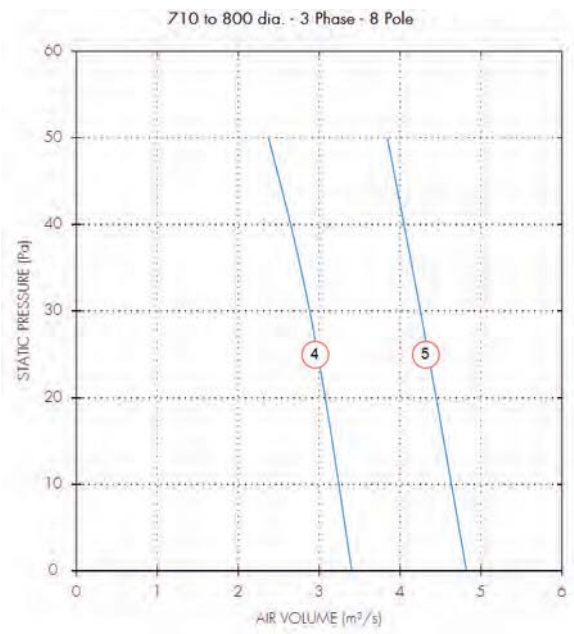
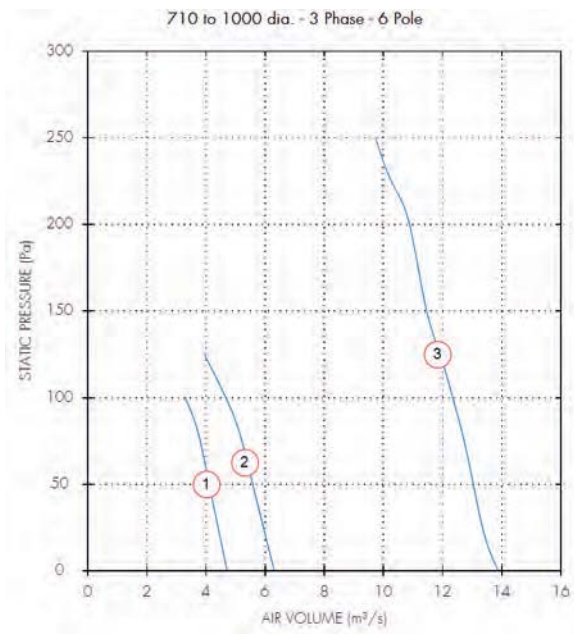

Dia.	Motor Phase	Stock Ref	Poles	r.p.m	IP Rating	Curve Ref.	m ³ /s @ Pa					Motor kW	S.C. Amps	F.L.C Amps	dBA @ 3m	
							0	50	100	150	200					250
710	3	ESP71036	6	860	IP54	1	4.71	4.11	3.29			1.1	7.7	2.2	62	
800	3	ESP80036	6	900	IP54	2	6.3	5.58	4.67			1.4	9.8	2.7	64	
1000	3	ESP100036	6	935	IP54	3	13.89	13.04	12.35	11.46	10.88	9.72	5.5	67	10.5	77
710	3	ESP71038	8	630	IP54	4	3.4	2.37				0.43	3.3	1.1	55	
800	3	ESP80038	8	670	IP54	5	4.82	3.84				0.69	5	1.75	58	

For fans wired to reverse run, duty reduced by 30%.

Sound Power Level Spectra dB (ref 10⁻¹² Watts)

Dia.	Motor Phase	Stock Ref	Poles	Spectrum	dB								dBA @ 3m
					63	125	250	500	1k	2k	4k	8k	
710	3	ESP71036	6	Inlet	80	77	78	75	76	75	70	64	60
710	3	ESP71036	6	Outlet	80	77	78	75	76	75	70	64	60
800	3	ESP80036	6	Inlet	73	83	79	75	75	77	74	64	62
800	3	ESP80036	6	Outlet	73	83	79	75	75	77	74	64	62
1000	3	ESP100036	6	Inlet	80	90	90	91	90	86	85	79	74
1000	3	ESP100036	6	Outlet	80	90	90	91	90	86	85	79	74
710	3	ESP71038	8	Inlet	75	75	73	71	72	70	64	57	56
710	3	ESP71038	8	Outlet	75	75	73	71	72	70	64	57	56
800	3	ESP80038	8	Inlet	75	75	73	71	72	70	64	57	56
800	3	ESP80038	8	Outlet	75	75	73	71	72	70	64	57	56

Models & Accessories

Fan Stock Ref	Speed Controllers				Fan Stock Ref	Speed Controller Auto Transfor. Stock Ref	Starter Stock Ref	Overload Stock Ref
	Elect 1ph Stock Ref	Auto Transfor. Stock Ref	Starter Stock Ref	Overload Stock Ref				
1 Phase - 2 Pole					3 Phase - 2 Pole			
ESP25012	SP5001	SPM5020	444744	444699	ESP25032	RDTK10	444747	444699
ESP31512	SP5025	SPM5035	444744	444701	ESP31532	RDTK20	444747	444700
					ESP35532	RDTK40	444747	444702
1 Phase - 4 Pole					3 Phase - 4 Pole			
ESP25014	SP5001	SPM5020	444744	444696	ESP31534	RDTK10	444747	444697
ESP31514	SP5001	SPM5020	444744	444699	ESP35534	RDTK10	444747	444698
ESP35514	SP5001	SPM5020	444744	444699	ESP40034	RDTK10	444747	444699
ESP40014	SP5025	SPM5020	444744	444701	ESP45034	RDTK10	444747	444699
ESP45014	SP5025	SPM5035	444744	444701	ESP50034	RDTK20	444747	444700
ESP50014	SP5025	SPM5035	444744	444702	ESP56034	RDTK40	444747	444701
ESP56014	SP5010	SPM5075	444744	444704	ESP63034	RDTK40	444747	444702
ESP63014	-	SPM5140	444744	444706	ESP71034	RDTK70	444747	444703
1 Phase - 6 Pole					3 Phase - 6 Pole			
ESP35516	SP5001	SPM5020	444744	444698	ESP35536	RDTK10	444747	444697
ESP40016	SP5001	SPM5020	444744	444699	ESP40036	RDTK10	444747	444697
					ESP45036	RDTK10	444747	444697
					ESP50036	RDTK10	444747	444699
ESP56016	SP5025	SPM5035	444744	444701	ESP56036	RDTK10	444747	444699
ESP63016	SP5050	SPM5035	444744	444702	ESP63036	RDTK20	444747	444700
ESP71016	SP5050	SPM5060	444744	444703	ESP71036	RDTK40	444747	444702
					ESP80036	RDTK40	444747	444702
					ESP100036*	-	444748	444706
1 Phase - 8 Pole					3 Phase - 8 Pole			
					ESP71038	RDTK20	444747	444700
					ESP80038	RDTK20	444747	444701

*Not suitable for voltage speed control. Inverter speed control with sine filters only.

Size	Roof Cowl Assembly Stock Ref	Louvre Shutter Stock Ref	Impeller Discharge Side Guard Stock Ref	Imp. Disch. Guard when used with LS shutter Stock Ref
250	RCZ300	LS250	10502325	10502375
315	RCZ300	LS315	10502325	10502375
355	RCZ300	LS350	10502375	10502450
400	RCZ400	LS400	10502450	10502525
450	RCZ400	LS450	10502525	10502630
500	RCZ500	LS500	10502525	10502630
560	RCZ500	LS560	10502630	10502630
630	RCZ630	LS630	10502630	10502800
710	RCZ630	LS710	10502800	10502800
800	RCZ800	LS800	10502800	105021000
1000	RCZ1000	LS1000	105021000	-

- Note:
- The Standard roof cowl colour is BS 00A 05 (Goose Wing Grey), for all special B.S. or RAL colours contact Vent-Axia.
 - When speed control is required a 5 step auto transformer speed controller is recommended, to ensure low noise levels.
 - All 3 phase models are suitable for frequency inverter speed control.
 - Vent-Axia only recommends using Inverters with integral Sine Filters for reliable operation.

EuroSeries (ESC)

Features & Benefits

- External rotor motors
- Die cast aluminium impellers
- Fully speed controllable
- Air Volumes up to 13.89m³/s
- Sizes 250 to 1000 protected to IP54
- Operating Temperatures from -40°C up to +70°C
- Motor Insulation Class F
- HOT SPOT Protection
- Reversible for supply or extract
- Tough epoxy paint finish
- Quality Assurance to BS EN ISO 9001:1994
- Performance tested to BS848 Part 1 1980



The new range of EuroSeries ESC Short Cased axial blade fans, feature a single shot die cast aluminium blade & external rotor motor design.

The EuroSeries ESC range is available in eleven sizes with the extract performances up to 13.89m³/s, with pressure characteristics of up to 300Pa. All units are designed for & fully speed controllable.

Impellers

All sizes shall be supplied with cast aluminium impellers, ensuring performance when working against outdoor conditions and abrasive airflow.

Motors

External rotor motors are specially designed and styled for this range of fan. Ball bearings shall be greased for life. Rotors are dynamically balanced to ISO 1940. Sizes 315-1000mm, motors are protected to IP54, against dust and moisture complying with BS EN 60529:1992. They shall be ribbed aluminium body castings for efficient cooling. Motor insulation is Class 'F' (from -40°C to +70°C).

Electrical

Single phase 220-240V 50Hz. Capacitor start and run. Three phase 380-415V 50Hz. An IP54 terminal box shall be supplied with most models with 20mm and PGII entry. All motors shall be fitted with thermal overload Protection which should be wired into all controller circuits and into starter contactors. Models are available with either 2,4, 6 & 8 pole motors.

Terminal Box

Terminal Box to IP54 as standard, protected against dust water from any angle allowing outside applications.

Performance

The fan performance, shall be in accordance with tests to BS848 Part 1 1980.

Sound Levels

Fan sound levels, measured in a reverberant chamber in accordance with BS848 Part 2 1985. Published dB(A) figures are free field sound pressure levels at 3m with spherical propagation at a reference level of 2×10^{-5} Pa (20 micro-Pascal). The sound power level spectra figures are dB with reference level of 10^{-12} Watts (1 pico-watt). To ensure minimum noise levels during speed control, an auto transformer speed control is recommended.

Accessories

A full range of accessories:

- Electronic Speed Controllers
- Auto Transformer Speed Controllers
- D.O.L. Starters & Overloads
- Ancillary Packs (comprising:- 4 AVM's, 2 mounting feet, 2 matching flanges, 2 flexible connectors + clips)
- Wire Guards
- Attenuators
- Mounting Feet
- Matching Flanges
- Anti Vibration Mounts
- Louvre Shutters

Dimensions (mm)

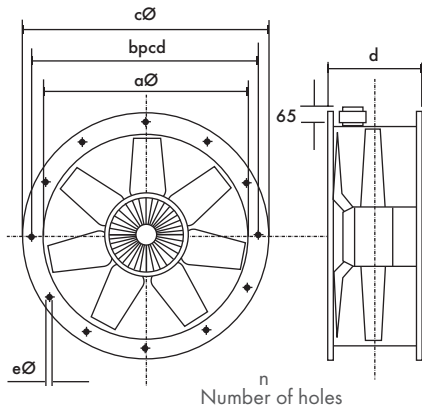

Dia	Øa	Øb	Øc	d	Øe	n	kg
250	254	286	306	110	7	8	5
315	316.5	356	382	135	9.5	8	6.1
355	356	395	421	135	9.5	8	7.1
400	400	438	466	155	9.5	12	8.1
450	451	487	515	160	9.5	12	13.4
500	503	541	567	166	9.5	12	15.7
560	559	605	635	210	11.5	16	20.1
630	634	674	707	220	11.5	16	44
710	711	751	785	260	11.5	16	31
800	797	837	871	280	11.5	24	39
1000	1001	1043	1080	330	11.5	24	73

Mounting Feet

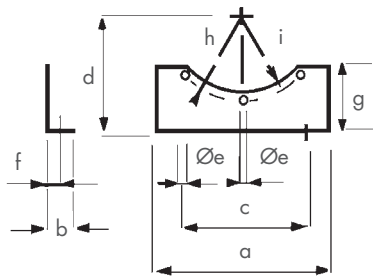

Stock Ref	a	b	c	d	Øe	f	g	h	i
MFZ315	315	40	265	200	10	20	71	178	166
MFZ355	350	40	300	225	10	20	81.5	198	186
MFZ400	250	40	220	250	10	20	78	219	205
MFZ450	275	40	240	275	10	20	82	244	230
MFZ500	315	50	280	315	1	25	100	271	255
MFZ560	355	50	320	355	12	25	97	303	285
MFZ630	400	50	360	400	12	25	109	337	320
MFZ710	465	50	415	450	12	25	119	376	362
MFZ800	458	50	420	518	12	25	176	419	405

Anti Vibration Mountings

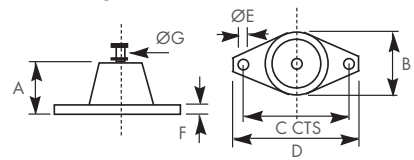

Stock Ref	A	B	C	D	ØE	F	ØG
68MP033G	27	37	54	67	7	3	M8

Coupling Flanges

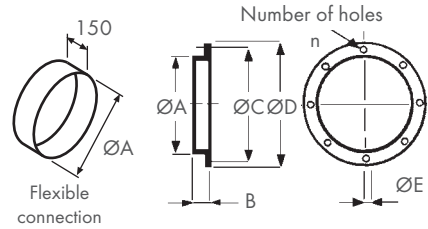

Stock Ref	ØA	B	ØC	ØD	ØE	n	Flexible Connection
CFZ315	313	40	356	382	10	8	FCZ315
CFZ355	353	40	395	421	10	8	FCZ355
CFZ400	398	45	438	466	10	12	FCZ400
CFZ450	448	45	487	515	10	12	FCZ450
CFZ500	498	45	541	567	10	12	FCZ500
CFZ560	558	45	605	635	12	16	FCZ560
CFZ630	628	45	674	707	12	16	FCZ630
CFZ710	708	50	751	785	12	16	FCZ710
CFZ800	798	50	837	871	12	24	FCZ800

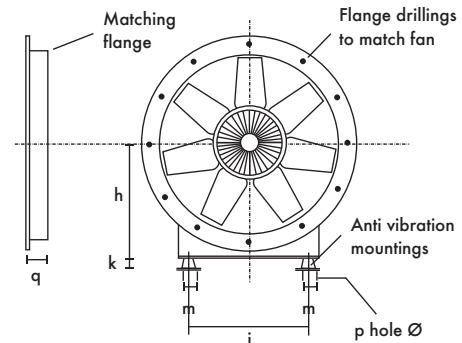

Unit size	h	i	k†	m	pØ	q
315	200	265	27	54	7	40
355	225	300	27	54	7	40
400	250	220	27	54	7	45
450	275	240	27	54	7	45
500	315	280	27	54	7	45
560	355	320	27	54	7	45
630	400	360	27	54	7	45
710	450	415	27	54	7	50
800	518	420	27	54	7	50

Performance Curves

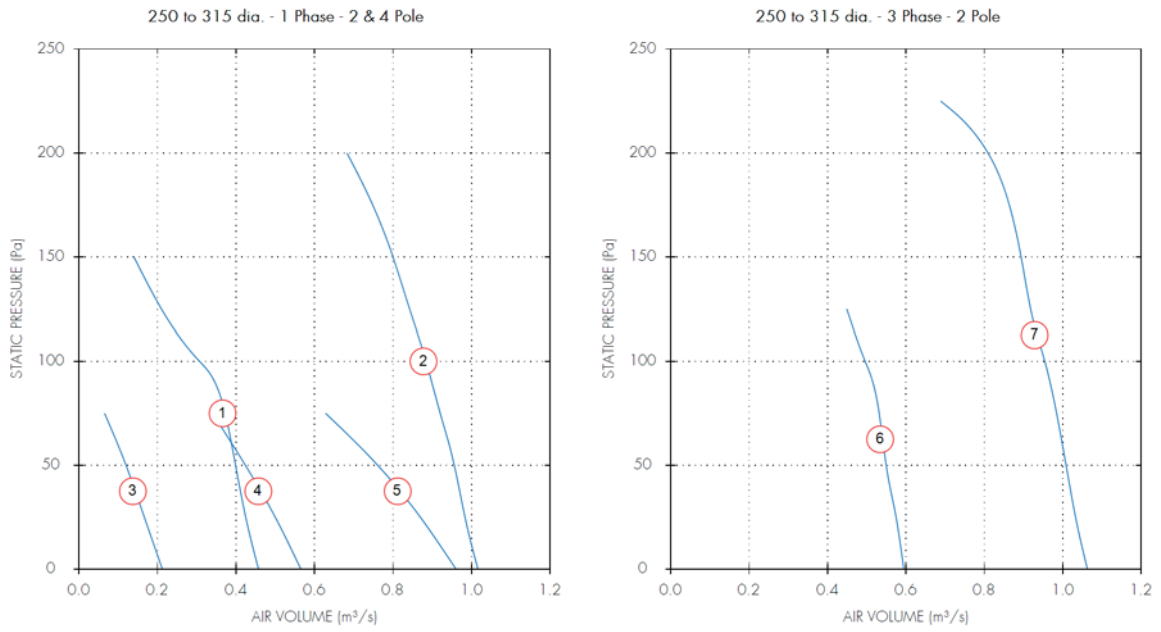

Performance Guide

Dia.	Motor Phase	Stock Ref	Poles	r.p.m	IP Rating	Curve Ref.	m³/s @ Pa					Motor kW	S.C. Amps	F.L.C Amps	dBA @ 3m
							0	50	100	150	200				
250	1	ESC25012	2	2440	IP44	1	0.46	0.4	0.31	0.14		0.12	1.15	0.54	59
315	1	ESC31512	2	2690	IP54	2	1.02	0.96	0.88	0.8	0.68	0.56	7.2	2.4	64
250	1	ESC25014	4	1340	IP44	3	0.21	0.12				0.04	0.3	0.16	44
315	1	ESC31514	4	1300	IP54	4	0.57	0.42				0.15	1.38	0.7	50
355	1	ESC35514	4	1330	IP54	5	0.96	0.76				0.19	1.45	0.84	53
250	3	ESC25032	2	2700	IP44	6	0.59	0.55	0.5			0.2	3.5	0.87	61
315	3	ESC31532	2	2800	IP54	7	1.06	1.01	0.95	0.89	0.81	0.48	5	0.9	60

For Fans wired to reverse run, duty reduced by 30%
 ESC25012, ESC31512 and ESC25014 not suitable for reverse airflow

Sound Power Level Spectra dB (ref 10⁻¹² Watts)

Dia.	Motor Phase	Stock Ref	Poles	Spectrum	dB								dBA @ 3m
					63	125	250	500	1k	2k	4k	8k	
250	1	ESC25012	2	Inlet	69	70	76	76	70	70	67	59	57
250	1	ESC25012	2	Outlet	69	70	76	76	70	70	67	59	57
315	1	ESC31512	2	Inlet	69	73	79	74	74	76	73	66	61
315	1	ESC31512	2	Outlet	69	73	79	74	74	76	73	66	61
250	1	ESC25014	4	Inlet	70	72	63	58	54	52	45	35	41
250	1	ESC25014	4	Outlet	70	72	63	58	54	52	45	35	41
315	1	ESC31514	4	Inlet	70	68	66	61	60	62	58	51	47
315	1	ESC31514	4	Outlet	70	68	66	61	60	62	58	51	47
355	1	ESC35514	4	Inlet	65	70	67	65	64	64	62	55	50
355	1	ESC35514	4	Outlet	65	70	67	65	64	64	62	55	50
250	3	ESC25032	2	Inlet	69	70	75	79	74	70	66	60	59
250	3	ESC25032	2	Outlet	70	75	79	74	70	66	60	60	56
315	3	ESC31532	2	Inlet	71	72	83	80	78	79	75	67	64
315	3	ESC31532	2	Outlet	71	72	83	80	78	79	75	67	64

Performance Curves

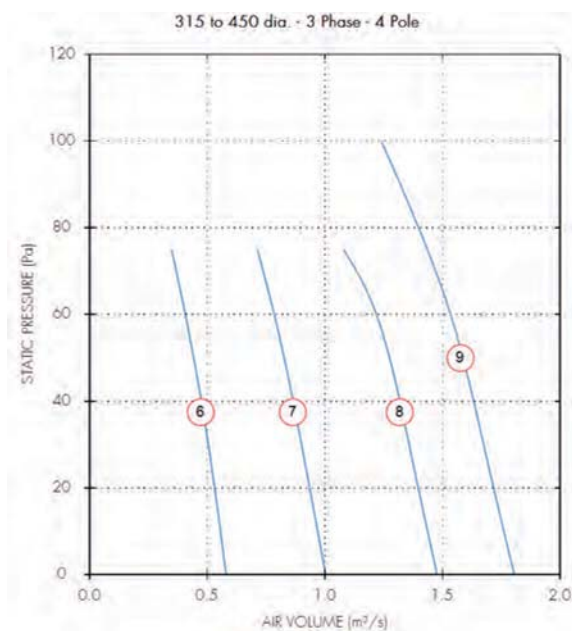
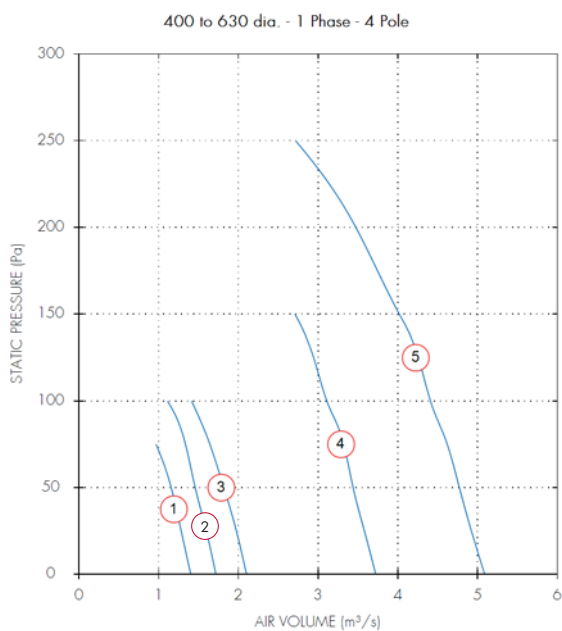

Performance Guide

Dia.	Motor Phase	Stock Ref	Poles	r.p.m	IP Rating	Curve Ref.	m³/s @ Pa						Motor kW	S.C. Amps	F.L.C Amps	dBA @ 3m	
							0	50	100	150	200	250					
400	1	ESC40014	4	1350	IP54	1	1.4	1.16						0.29	2.4	1.45	56
450	1	ESC45014	4	1370	IP54	2	1.72	1.46	1.11					0.36	3.6	1.6	61
500	1	ESC50014	4	1290	IP54	3	2.1	1.82	1.41					0.51	4.3	2.3	55
560	1	ESC56014	4	1320	IP54	4	3.72	3.44	3.11	2.71				1.4	9.3	6	63
630	1	ESC63014	4	1320	IP54	5	5.09	4.77	4.41	4.02	3.47	2.72	2.2	28	9.9		70
315	3	ESC31534	4	1390	IP54	6	0.58	0.44						0.11	2.1	0.27	46
355	3	ESC35534	4	1370	IP54	7	1	0.83						0.17	1.35	0.37	49
400	3	ESC40034	4	1350	IP54	8	1.48	1.27						0.26	2.1	0.56	51
450	3	ESC45034	4	1380	IP54	9	1.8	1.59	1.24					0.36	2.6	0.8	56

For Fans wired to reverse run, duty reduced by 30%

Sound Power Level Spectra dB (ref 10⁻¹² Watts)

Dia.	Motor Phase	Stock Ref	Poles	Spectrum	63	125	250	500	1k	2k	4k	8k	dBA @ 3m
400	1	ESC40014	4	Inlet	70	72	67	66	65	65	64	56	51
400	1	ESC40014	4	Outlet	70	72	67	66	65	65	64	56	51
450	1	ESC45014	4	Inlet	69	76	73	72	70	71	70	62	57
450	1	ESC45014	4	Outlet	69	76	73	72	70	71	70	62	57
500	1	ESC50014	4	Inlet	65	75	69	70	70	71	69	62	56
500	1	ESC50014	4	Outlet	65	75	69	70	70	71	69	62	56
560	1	ESC56014	4	Inlet	100	90	89	84	82	79	75	68	67
560	1	ESC56014	4	Outlet	100	90	89	84	82	79	75	68	67
630	1	ESC63014	4	Inlet	82	86	79	79	80	78	75	70	64
630	1	ESC63014	4	Outlet	82	86	79	79	80	78	75	70	64
315	3	ESC31534	4	Inlet	64	67	69	63	62	60	58	53	47
315	3	ESC31534	4	Outlet	64	67	69	63	62	60	58	53	47
355	3	ESC35534	4	Inlet	58	73	63	64	64	65	64	58	50
355	3	ESC35534	4	Outlet	58	73	63	64	64	65	64	58	50
400	3	ESC40034	4	Inlet	62	73	65	65	67	69	67	60	53
400	3	ESC40034	4	Outlet	62	73	65	65	67	69	67	60	53
450	3	ESC45034	4	Inlet	65	82	75	76	73	72	69	62	58
450	3	ESC45034	4	Outlet	65	82	75	76	73	72	69	62	58

Performance Curves

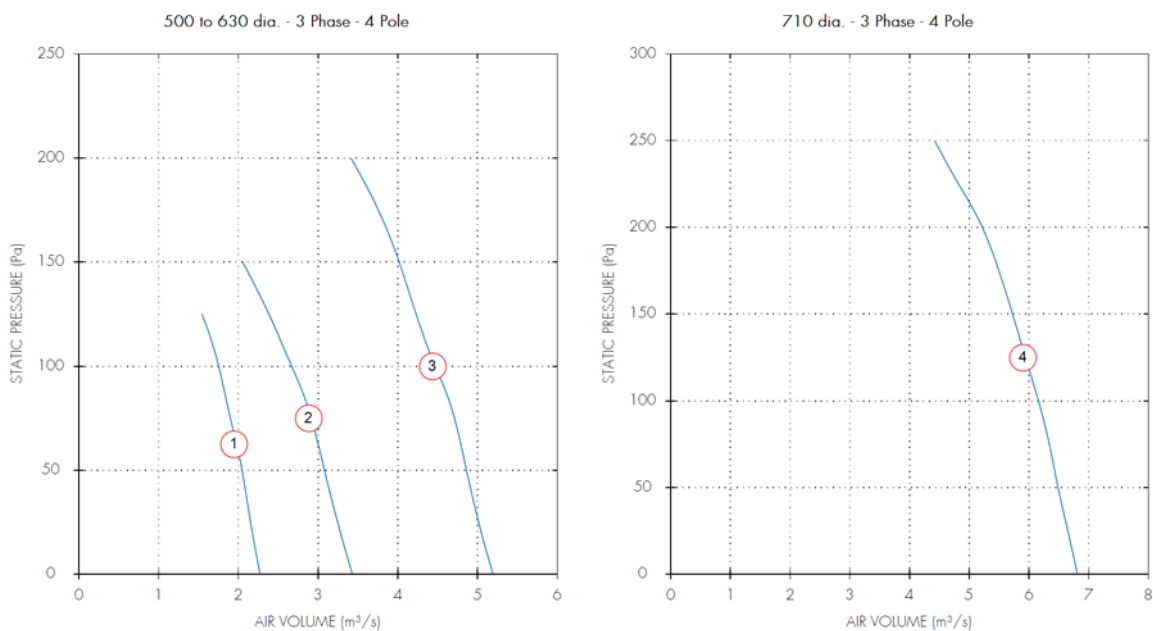

Performance Guide

Dia.	Motor Phase	Stock Ref	Poles	r.p.m	IP Rating	Curve Ref.	m ³ /s @ Pa					Motor kW	S.C. Amps	F.L.C Amps	dBA @ 3m
							0	50	100	150	200				
500	3	ESC50034	4	1380	IP54	1	2.27	2.05	1.75			0.55	4.2	1.05	58
560	3	ESC56034	4	1220	IP54	2	3.43	3.08	2.67	2.05		1.25	7.7	2.2	70
630	3	ESC63034	4	1360	IP54	3	5.19	4.86	4.47	4.02	3.41	1.9	14	3.2	64
710	3	ESC71034	4	1290	IP54	4	6.81	6.49	6.16	5.72	5.22	2.9	19	5.3	72

For Fans wired to reverse run, duty reduced by 30%

Sound Power Level Spectra dB (ref 10⁻¹² Watts)

Dia.	Motor Phase	Stock Ref	Poles	Spectrum	dB								dBA @ 3m
					63	125	250	500	1k	2k	4k	8k	
500	3	ESC50034	4	Inlet	67	71	69	72	70	71	68	61	56
500	3	ESC50034	4	Outlet	67	71	69	72	70	71	68	61	56
560	3	ESC56034	4	Inlet	85	79	77	76	76	75	72	66	61
560	3	ESC56034	4	Outlet	85	79	77	76	76	75	72	66	61
630	3	ESC63034	4	Inlet	71	88	82	83	82	81	78	72	67
630	3	ESC63034	4	Outlet	71	88	82	83	82	81	78	72	67
710	3	ESC71034	4	Inlet	80	87	86	88	89	86	83	79	72
710	3	ESC71034	4	Outlet	80	87	86	88	89	86	83	79	72

Performance Curves

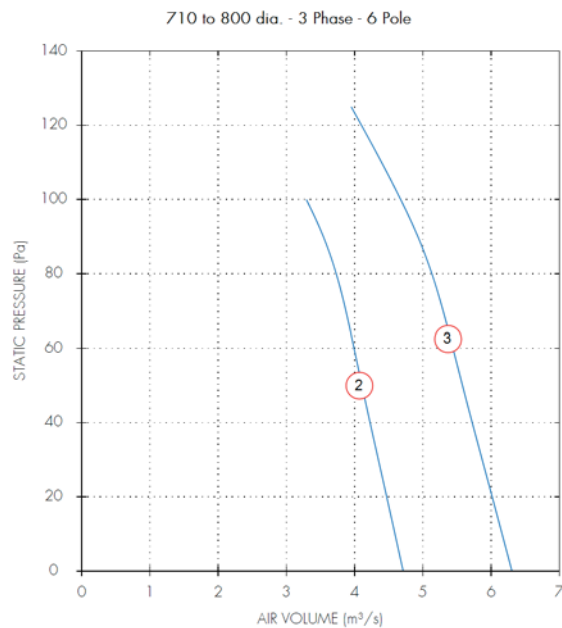
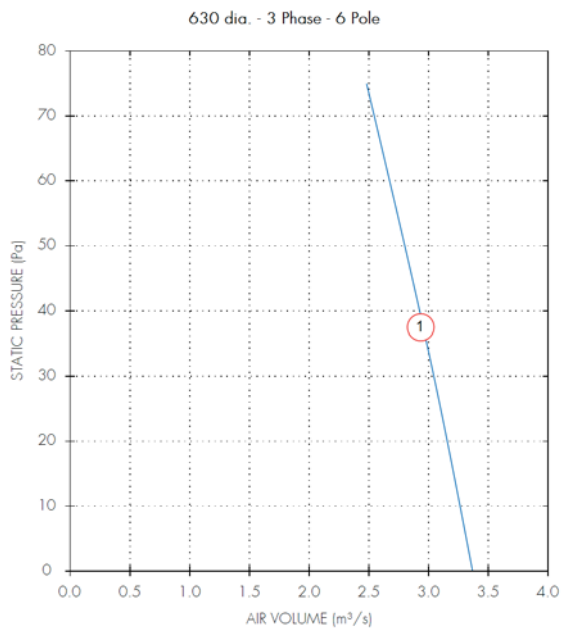

Performance Guide

Dia.	Motor Phase	Stock Ref	Poles	r.p.m	IP Rating	Curve Ref.	m ³ /s @ Pa						F.L.C			
							0	25	50	75	100	125	Motor kW	S.C. Amps	Amps	dBA @ 3m
630	3	ESC63036	6	890	IP54	1	3.37	3.1	2.8	2.48			0.59	3.6	1.3	59
710	3	ESC71036	6	860	IP54	2	4.71	4.41	4.11	3.8	3.29		1.1	7.7	2.2	62
800	3	ESC80036	6	900	IP54	3	6.3	5.94	5.58	5.22	4.67	3.95	1.4	9.8	2.7	64

For Fans wired to reverse run, duty reduced by 30%

Sound Power Level Spectra dB (ref 10⁻¹² Watts)

Dia.	Motor Phase	Stock Ref	Poles	Spectrum	dB										dBA @ 3m
					63	125	250	500	1k	2k	4k	8k			
630	3	ESC63036	6	Inlet	67	78	76	74	73	72	77	59	60		
630	3	ESC63036	6	Outlet	67	78	76	74	73	72	77	59	60		
710	3	ESC71036	6	Inlet	80	77	78	75	76	75	70	64	60		
710	3	ESC71036	6	Outlet	80	77	78	75	76	75	70	64	60		
800	3	ESC80036	6	Inlet	75	75	73	71	72	70	64	57	56		
800	3	ESC80036	6	Outlet	75	75	73	71	72	70	64	57	56		

Starter Stock Ref	Overload Stock Ref	Ancillary Packs Stock Ref	Mounting Feet (pair) Stock Ref	Matching Flanges (each) Stock Ref	Wire Guards (each) Stock Ref	Anti-Vibration Mounts (set of 4) Stock Ref
444747	444699	APZ250	MFZ250	CFZ250	WGZ250	68MP033G
444747	444700	APZ315	MFZ315	CFZ315	WGZ315	68MP033G
		APZ250	MFZ250	CFZ250	WGZ250	68MP033G
444747	444697	APZ315	MFZ315	CFZ315	WGZ315	68MP033G
444747	444698	APZ355	MFZ355	CFZ355	WGZ355	68MP033G
444747	444699	APZ400	MFZ400	CFZ400	WGZ400	68MP033G
444747	444699	APZ450	MFZ450	CFZ450	WGZ450	68MP033G
444747	444700	APZ500	MFZ500	CFZ500	WGZ500	68MP033G
444747	444701	APZ560	MFZ560	CFZ560	WGZ560	68MP033G
444747	444702	APZ630	MFZ630	CFZ630	WGZ630	68MP033G
444747	444703	APZ710	MFZ710	CFZ710	WGZ710	68MP033G
444747	444700	APZ630	MFZ630	CFZ630	WGZ630	68MP033G
444747	444702	APZ710	MFZ710	CFZ710	WGZ710	68MP033G
444747	444702	APZ800	MFZ800	CFZ800	WGZ800	68MP033G

- Note:
- The Standard roof cowl colour is BS 00A 05 (Goose Wing Grey) for all special B.S. or RAL colours contact Vent-Axia.
 - When speed control is required a 5 step auto transformer speed controller is recommended, to ensure low noise levels.
 - All 3 phase models are suitable for frequency inverter speed control.
 - Vent-Axia only recommends using Inverters with integral Sine Filters for reliable operation.

EuroSeries (ESR)

Features & Benefits

- Cowl & base moulded from recyclable polymeric material
- All sizes resistant to UV light
- Sizes 315 to 1000 dia are protected to IP54
- Optional backdraught shutters and bird guard (250-630mm)
- All models speed controllable
- Motor Insulation Class F, -40°C to +70°C operating temperature
- Reversible for supply or extract units
- Thermal overload for motor protection
- Performance tested to BS848 part 1 1980
- Designed for Data Centre and Warehouse cooling



A new range of extract axial blade industrial roof fans incorporating the new Euroseries ESP axial plate fan, featuring a single shot die cast aluminium blade & external rotor motor design.

Cowl and roof mounting base are moulded from specially formulated recyclable polymeric materials, which are high impact resistant and provide a rigid profile against strong winds and resistance to UV light. Standard colour BS00A05

EuroSeries ESR units shall be suitable for flat or inclined roofs (max. angle 30°) and are designed for either kerb or purlin box mounting.

The EuroSeries ESR range is available in eleven sizes with the extract performances up to 10.88m³/s, with pressure characteristics of up to 300Pa. All units are designed for & fully speed controllable.

Air Operated Shutters & Bird Guards

The shutters shall fit beneath the cowl using fitting provided. Shutters should not be used when the fan performance is below 30% of maximum and the hinge should point up the roof incline.

The standard shutters for sizes 800 & 1000mm must not be used with 4 & 6 pole unit. Please enquire for special metal shutters. Bird Guards are manufactured to fit neatly between the roof cowl and the base.

Impellers

All sizes shall be supplied with cast aluminium impellers, ensuring performance when working against outdoor conditions and abrasive airflow. All fans are reversible for Intake (-30% performance). Backdraught shutters should not be used when operated as an intake fan.

Motors

External rotor motors are specially designed and styled for this range of fan. Ball bearings shall be greased for life. Rotors are dynamically balanced to ISO 1940. Sizes 315-1000mm, motors are protected to

IP54, against dust and moisture complying with BS EN 60529:1992. They shall be ribbed aluminium body castings for efficient cooling. Motor insulation is Class 'F' (from -40°C to +70°C).

Electrical

Single phase 220-240V 50Hz. Capacitor start and run. Three phase 380-415V 50Hz. An IP54 terminal box shall be supplied with most models with 20mm and PGII entry. All motors shall be fitted with thermal overload protection which should be wired into all controller circuits and into starter contactors. Models are available with either 2, 4, 6 & 8 pole motors.

Terminal Box

Are to IP54, as standard, protected against dust water from any angle allowing outside applications.

Performance

The fan performance, shall be in accordance with tests to BS848 Part 1 1980.

Sound Levels

Fan sound levels, measured in a reverberant chamber in accordance with BS848 Part 2 1985. Published dB(A) figures are free field sound pressure levels at 3m with spherical propagation at a reference level of 2 x 10⁻⁵ Pa (20 micro-Pascal). The sound power level spectra figures are dB with reference level of 10-12 Watts (1 pico-watt). To ensure minimum noise levels during speed control, an auto transformer speed control is recommended.

Fan Dimensions (mm)

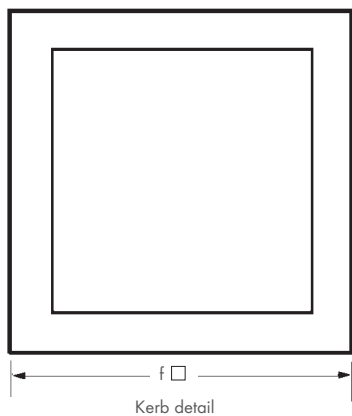
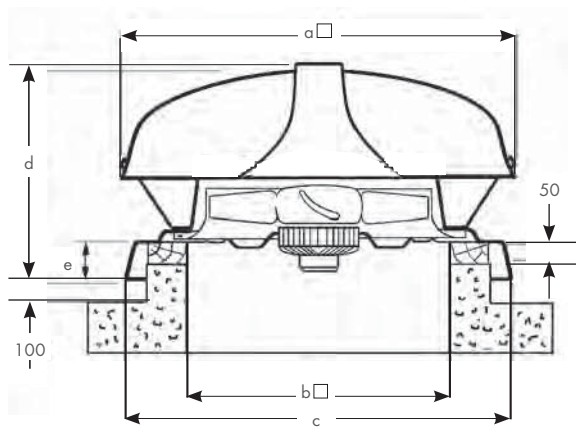

Size	a	b	c	d	e	f	kg Max
250	700	475	737	411	97	675	13.25
315	700	475	737	411	97	675	16.3
355	700	475	737	411	97	675	16.3
400	800	575	830	466	97	775	18.4
450	800	575	830	466	97	775	20.3
500	950	715	1000	579	100	915	35.5
560	950	715	1000	579	100	915	35.5
630	1230	840	1100	731	105	1040	62
710	1230	840	1100	731	105	1040	62
800	1420	870	1190	731	105	1070	78
1000	1680	1070	1455	795	131	1270	134

Purlin Box (mm)

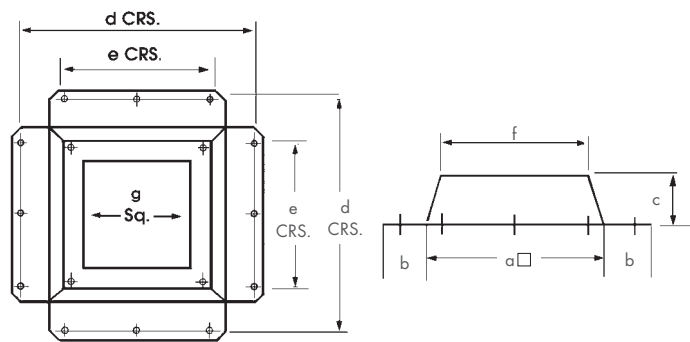

Size	a	b	c	d	e	f	g
250	625	90	240	765	400	590	460
315	625	90	240	765	400	590	460
355	625	90	240	765	400	590	460
400	725	90	240	865	500	705	565
450	725	90	240	865	500	705	565
500	890	70	250	990	650	850	640
560	890	70	250	990	650	870	700
630	1030	75	250	1140	760	985	775
710	1030	75	250	1140	760	985	840
800	980	37	267	1016	406	980	880
1000	1180	76	279	1294	508	1180	1080

Performance Curves

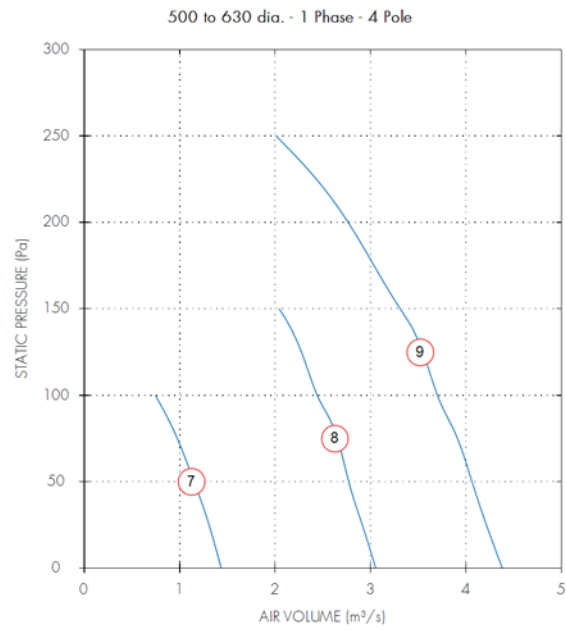
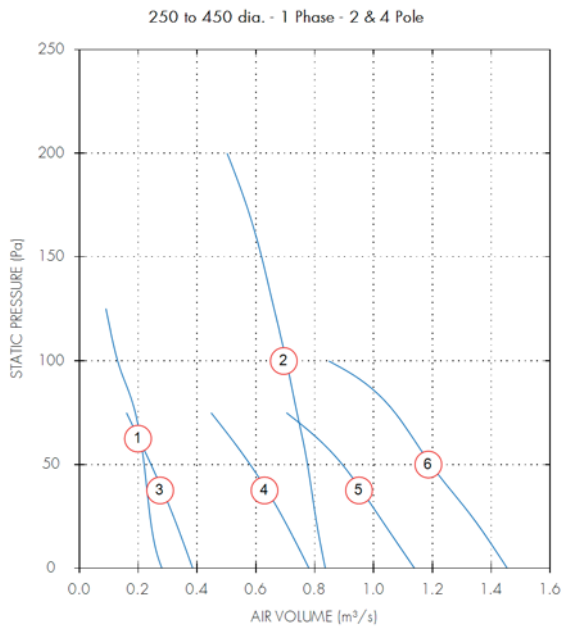

Performance Guide

Dia.	Motor Phase	Stock Ref	Poles	r.p.m	IP Rating	Curve Ref.	m³/s @ Pa					Motor kW	S.C. Amps	F.L.C Amps	dBA @ 3m
							0	50	100	150	200				
250	1	ESR25012	2	2440	IP44	1	0.28	0.22	0.13			0.12	1.15	0.54	59
315	1	ESR31512	2	2690	IP54	2	0.84	0.78	0.7	0.62	0.5	0.56	72	2.4	64
315	1	ESR31514	4	1300	IP54	3	0.38	0.24				0.15	1.38	0.7	50
355	1	ESR35514	4	1330	IP54	4	0.78	0.58				0.19	1.45	0.84	53
400	1	ESR40014	4	1350	IP54	5	1.14	0.89				0.29	2.4	1.45	56
450	1	ESR45014	4	1370	IP54	6	1.45	1.19	0.85			0.36	3.6	1.6	61
500	1	ESR50014	4	1290	IP54	7	1.43	1.15	0.75			0.51	4.3	2.3	55
560	1	ESR56014	4	1320	IP54	8	3.05	2.77	2.44	2.04		1.35	21	6	63
630	1	ESR63014	4	1320	IP54	9	4.38	4.06	3.7	3.31	2.76	2.2	28	9.9	70

ESR25012, ESR31512 & ESR25014 not suitable for reverse airflow.

Sound Power Level Spectra dB (ref 10⁻¹² Watts)

Dia.	Motor Phase	Stock Ref	Poles	Spectrum	dB								dBA @ 3m
					63	125	250	500	1k	2k	4k	8k	
250	1	ESR25012	2	Inlet	69	70	76	76	70	70	67	59	57
250	1	ESR25012	2	Outlet	69	70	76	76	70	70	67	59	57
315	1	ESR31512	2	Inlet	69	73	79	74	74	76	73	66	61
315	1	ESR31512	2	Outlet	69	73	79	74	74	76	73	66	61
315	1	ESR31514	4	Inlet	70	68	66	61	60	62	58	51	47
315	1	ESR31514	4	Outlet	70	68	66	61	60	62	58	51	47
355	1	ESR35514	4	Inlet	65	70	67	65	64	64	62	55	50
355	1	ESR35514	4	Outlet	65	70	67	65	64	64	62	55	50
400	1	ESR40014	4	Inlet	70	72	67	66	65	65	64	56	51
400	1	ESR40014	4	Outlet	70	72	67	66	65	65	64	56	51
450	1	ESR45014	4	Inlet	69	76	73	72	70	71	70	62	57
450	1	ESR45014	4	Outlet	69	76	73	72	70	71	70	62	57
500	1	ESR50014	4	Inlet	65	75	69	70	70	71	69	62	56
500	1	ESR50014	4	Outlet	65	75	69	70	70	71	69	62	56
560	1	ESR56014	4	Inlet	100	90	89	84	82	79	75	68	67
560	1	ESR56014	4	Outlet	100	90	89	84	82	79	75	68	67
630	1	ESR63014	4	Inlet	82	86	79	79	80	78	75	70	64
630	1	ESR63014	4	Outlet	82	86	79	79	80	78	75	70	64

Performance Curves

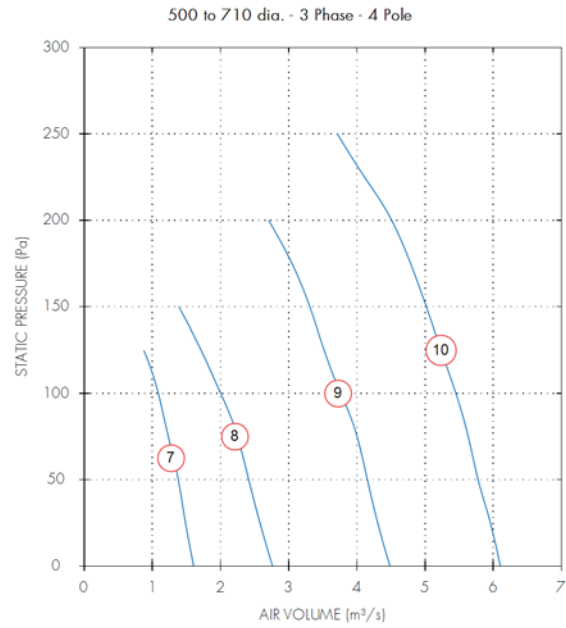
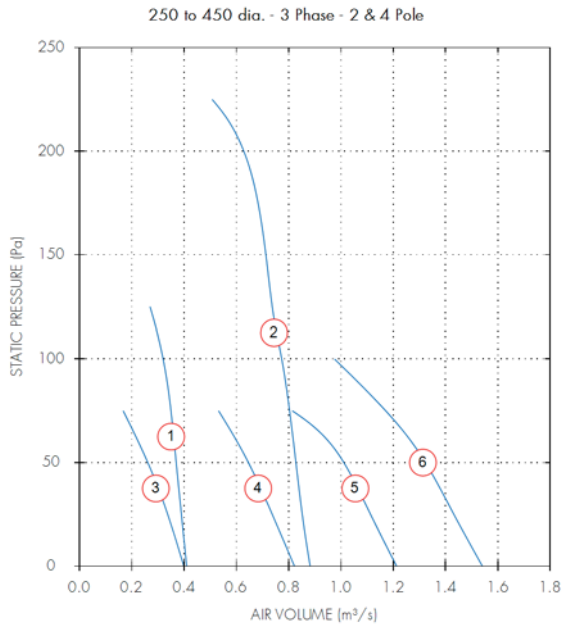

Performance Guide

Dia.	Motor Phase	Stock Ref	Poles	r.p.m	IP Rating	Curve Ref.	m ³ /s @ Pa						Motor kW	S.C.	Amps F.L.C	Amps dBA @ 3m
							0	50	100	150	200	250				
250	3	ESR25032	2	2700	IP44	1	0.41	0.37	0.32				0.2	3.5	0.87	61
315	3	ESR31532	2	2800	IP54	2	0.88	0.83	0.77	0.71	0.63		0.48	5	0.9	60
315	3	ESR31534	4	1390	IP54	3	0.4	0.26					0.11	2.1	0.27	46
355	3	ESR35534	4	1370	IP54	4	0.82	0.65					0.17	1.35	0.37	49
400	3	ESR40034	4	1350	IP54	5	1.21	1.01					0.26	2.1	0.56	51
450	3	ESR45034	4	1380	IP54	6	1.54	1.32	0.98				0.36	2.6	0.8	56
500	3	ESR50034	4	1380	IP54	7	1.6	1.38	1.09				0.55	3.7	1.05	58
560	3	ESR56034	4	1220	IP54	8	2.76	2.41	2	1.39			1.25	7.7	2.2	70
630	3	ESR63034	4	1360	IP54	9	4.49	4.15	3.76	3.31	2.7		1.9	14	3.2	64
710	3	ESR71034	4	1290	IP54	10	6.1	5.78	5.45	5.02	4.51	3.71	2.9	19	5.3	72

Sound Power Level Spectra dB (ref 10⁻¹² Watts)

Dia.	Motor Phase	Stock Ref	Poles	Spectrum	dB								dBA @ 3m
					63	125	250	500	1k	2k	4k	8k	
250	3	ESR25032	2	Inlet	69	70	75	79	74	70	66	60	59
250	3	ESR25032	2	Outlet	69	70	75	79	74	70	66	60	59
315	3	ESR31532	2	Inlet	71	72	83	80	78	79	75	67	64
315	3	ESR31532	2	Outlet	71	72	83	80	78	79	75	67	64
315	3	ESR31534	4	Inlet	64	67	69	63	62	60	58	53	47
315	3	ESR31534	4	Outlet	64	67	69	63	62	60	58	53	47
355	3	ESR35534	4	Inlet	58	73	63	64	64	65	64	58	50
355	3	ESR35534	4	Outlet	58	73	63	64	64	65	64	58	50
400	3	ESR40034	4	Inlet	62	73	65	65	67	69	67	60	53
400	3	ESR40034	4	Outlet	62	73	65	65	67	69	67	60	53
450	3	ESR45034	4	Inlet	65	82	75	76	73	72	69	62	58
450	3	ESR45034	4	Outlet	65	82	75	76	73	72	69	62	58
500	3	ESR50034	4	Inlet	67	71	69	72	70	71	68	61	56
500	3	ESR50034	4	Outlet	67	71	69	72	70	71	68	61	56
560	3	ESR56034	4	Inlet	85	79	77	76	76	75	72	66	61
560	3	ESR56034	4	Outlet	85	79	77	76	76	75	72	66	61
630	3	ESR63034	4	Inlet	71	88	82	83	82	81	78	72	67
630	3	ESR63034	4	Outlet	71	88	82	83	82	81	78	72	67
710	3	ESR71034	4	Inlet	80	87	86	88	89	86	83	79	72
710	3	ESR71034	4	Outlet	80	87	86	88	89	86	83	79	72

Performance Curves

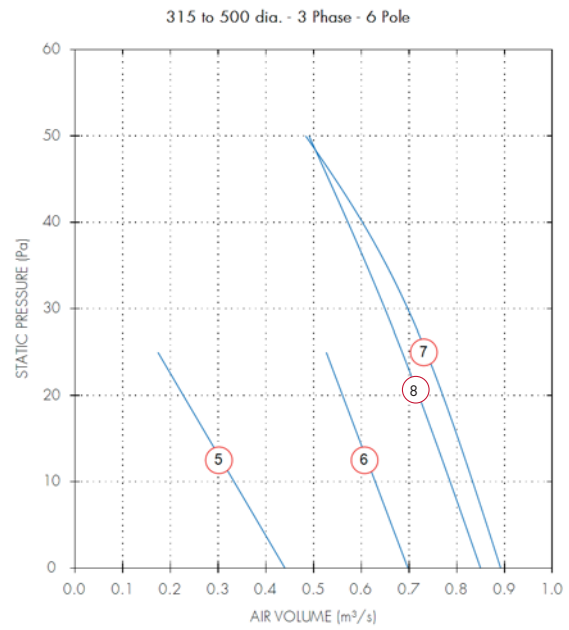
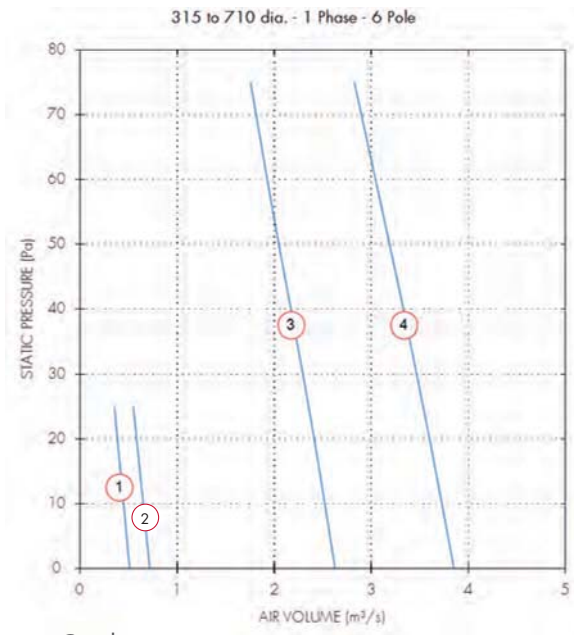

Performance Guide

Dia.	Motor Phase	Stock Ref	Poles	r.p.m	IP Rating	Curve Ref.	m ³ /s @ Pa				Motor kW	S.C. Amps	F.L.C Amps	dBA @ 3m
							0	25	50	75				
355	1	ESR35516	6	950	IP54	1	0.51	0.35			0.09	1.2	0.46	44
400	1	ESR40016	6	940	IP54	2	0.72	0.55			0.13	1.4	0.6	45
630	1	ESR63016	6	880	IP54	3	2.63	2.35	2.05	1.76	0.6	5.3	2.7	57
710	1	ESR71016	6	850	IP54	4	3.85	3.53	3.19	2.82	0.89	8	4.1	60
355	3	ESR35536	6	910	IP54	5	0.44	0.17			0.09	0.5	0.25	45
400	3	ESR40036	6	920	IP54	6	0.7	0.53			0.11	0.9	0.28	50
450	3	ESR45036	6	890	IP54	7	0.89	0.74	0.48		0.12	1	0.28	51
500	3	ESR50036	6	900	IP54	8	0.85	0.69	0.49		0.23	1.5	0.56	56

Sound Power Level Spectra dB (ref 10⁻¹² Watts)

Dia.	Motor Phase	Stock Ref	Poles	Spectrum	dB @ 3m								
					63	125	250	500	1k	2k	4k	8k	
355	1	ESR35516	6	Inlet	59	59	60	57	56	57	55	46	42
355	1	ESR35516	6	Outlet	59	59	60	57	56	57	55	46	42
400	1	ESR40016	6	Inlet	76	74	70	65	63	58	52	44	48
400	1	ESR40016	6	Outlet	76	74	70	65	63	58	52	44	48
630	1	ESR63016	6	Inlet	88	85	81	77	76	70	64	58	60
630	1	ESR63016	6	Outlet	88	85	81	77	76	70	64	58	60
710	1	ESR71016	6	Inlet	83	83	84	80	78	74	70	72	63
710	1	ESR71016	6	Outlet	83	83	84	80	78	74	70	72	63
355	3	ESR35536	6	Inlet	60	61	60	56	56	56	54	46	42
355	3	ESR35536	6	Outlet	60	61	60	56	56	56	54	46	42
400	3	ESR40036	6	Inlet	60	60	62	59	60	60	58	50	45
400	3	ESR40036	6	Outlet	60	60	62	59	60	60	58	50	45
450	3	ESR45036	6	Inlet	63	72	66	63	63	62	59	48	48
450	3	ESR45036	6	Outlet	63	72	66	63	63	62	59	48	48
500	3	ESR50036	6	Inlet	78	73	68	67	68	66	59	51	52
500	3	ESR50036	6	Outlet	78	73	68	67	68	66	59	51	52

Performance Curves

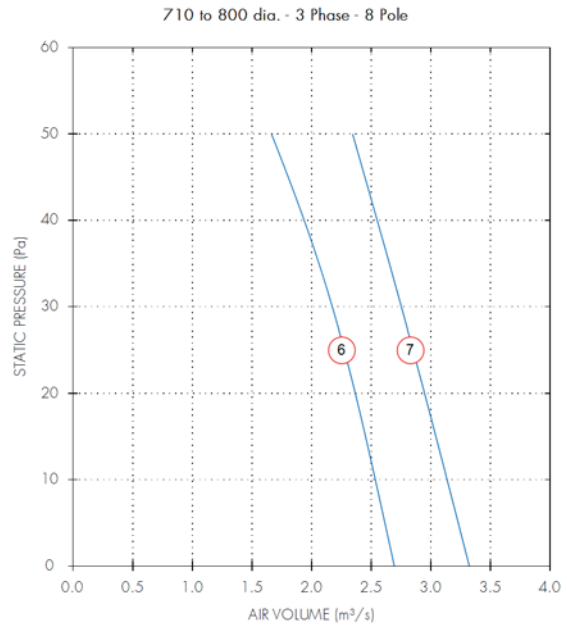
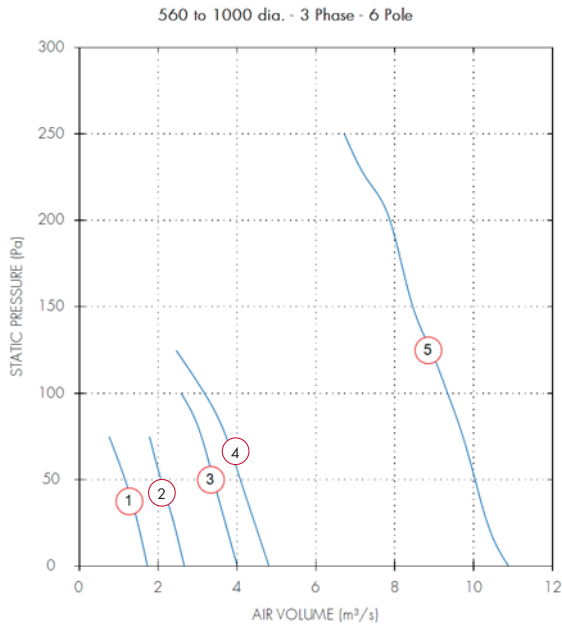

Performance Guide

Dia.	Motor Phase	Stock Ref	Poles	r.p.m	IP Rating	Curve Ref.	m ³ /s @ Pa							Motor kW	S.C. Amps	F.L.C Amps	dBA @ 3m	
							0	50	100	150	200	250						
560	3	ESR56036	6	860	IP54	1	1.72	1.16							0.36	1.75	0.74	56
630	3	ESR63036	6	890	IP54	2	2.66	2.07							0.59	3.6	1.3	59
710	3	ESR71036	6	860	IP54	3	4	3.4	2.58						1.1	7.7	2.2	62
800	3	ESR80036	6	900	IP54	4	4.81	4.08	3.18						1.4	7.7	2.2	64
1000	3	ESR100036	6	935	IP54	5	10.88	10.04	9.34	8.45	7.87	6.72			5.5	67	10.5	77
710	3	ESR71038	8	630	IP54	6	2.69	1.66							0.43	3.3	1.1	55
800	3	ESR80038	8	670	IP54	7	3.32	2.34							0.69	5	1.75	58

Sound Power Level Spectra dB (ref 10⁻¹² Watts)

Dia.	Motor Phase	Stock Ref	Poles	Spectrum	dB								dBA @ 3m
					63	125	250	500	1k	2k	4k	8k	
560	3	ESR56036	6	Inlet	67	72	72	68	68	68	65	57	53
560	3	ESR56036	6	Outlet	67	72	72	68	68	68	65	57	53
630	3	ESR63036	6	Inlet	67	78	76	74	73	72	77	59	60
630	3	ESR63036	6	Outlet	67	78	76	74	73	72	77	59	60
710	3	ESR71036	6	Inlet	80	77	78	75	76	75	70	64	60
710	3	ESR71036	6	Outlet	80	77	78	75	76	75	70	64	60
800	3	ESR80036	6	Inlet	73	83	79	75	75	77	74	64	62
800	3	ESR80036	6	Outlet	73	83	79	75	75	77	74	64	62
1000	3	ESR100036	6	Inlet	80	90	90	91	90	86	85	79	74
1000	3	ESR100036	6	Outlet	80	90	90	91	90	86	85	79	74
710	3	ESR71038	8	Inlet	75	75	73	71	72	70	64	57	56
710	3	ESR71038	8	Outlet	75	75	73	71	72	70	64	57	56
800	3	ESR80038	8	Inlet	75	75	73	71	72	70	64	57	56
800	3	ESR80038	8	Outlet	75	75	73	71	72	70	64	57	56

Models & Accessories

Fan Stock Ref	Speed Controllers				Overload Stock Ref	Fan Stock Ref
	Electronic	Auto	Starter			
	1ph Stock Ref	Transfor 1ph Stock Ref	1 phase Ref			
1 Phase - 2 Pole						3 Phase - 2 Pole
ESR25012	SP5001	SPM5020	444744	444699		ESR25032
ESR31512	SP5025	SPM5035	444744	444701		ESR31532
1 Phase - 4 Pole						3 Phase - 4 Pole
ESR25014	SP5001	SPM5020	444744	444696		
ESR31514	SP5001	SPM5020	444744	444699		ESR31534
ESR35514	SP5001	SPM5020	444744	444699		ESR35534
ESR40014	SP5025	SPM5020	444744	444701		ESR40034
ESR45014	SP5025	SPM5020	444744	444701		ESR45034
ESR50014	SP5025	SPM5035	444744	444702		ESR50034
ESR56014	SP5010	SPM5075	444744	444704		ESR56034
ESR63014		SPM5140	444744	444706		ESR63034
						ESR71034
1 Phase - 6 Pole						3 Phase - 6 Pole
ESR35516	SP5001	SPM5020	444744	444698		ESR35536
ESR40016	SP5001	SPM5020	444744	444699		ESR40036
						ESR50036
						ESR56036
ESR63016	SP5050	SPM5035	444744	444702		ESR63036
ESR71016	SP5050	SPM5060	444744	444703		ESR71036
						ESR80036
						ESR100036*
						3 Phase - 6 Pole
						ESR63038
						ESR71038
						ESR80038

*Not suitable for voltage speed control. Inverter speed control with sine filters only.

Model Ref	Roof Cowl Assembly	Drop in Curb Attenuator		
	ONLY (No Fan)	(600mm)	(900mm)	(1200mm)
	Stock Ref	Stock Ref	Stock Ref	Stock Ref
ESR250	-	RAZ300600	RAZ300900	-
ESR315 & 355	RCZ300	RAZ300600	RAZ300900	RAZ3001200
ESR400 & 450	RCZ400	RAZ400600	RAZ400900	RAZ4001200
ESR500 & 560	RCZ500	RAZ500600	RAZ500900	RAZ5001200
ESR630	RCZ630	RAZ600600	RAZ600900	RAZ6001200
ESR710	RCZ630	RAZ600600	RAZ600900	RAZ6001200
ESR800	RCZ800			
ESR1000	RCZ1000			

Speed Controllers

Auto Transfor 3ph Stock Ref	Starter 3 phase Stock Ref	Overload Stock Ref	Shutters Stock Ref	Birdguard Stock Ref	Adaptor Units (Purlin Box) Stock Ref
RDTK10	444747	444699	RSZ300	BGZ300	PBZ300
RDTK10	444747	444700	RSZ300	BGZ300	PBZ300
			RSZ300	BGZ300	PBZ300
RDTK10	444747	444697	RSZ300	BGZ300	PBZ300
RDTK10	444747	444698	RSZ300	BGZ300	PBZ300
RDTK10	444747	444699	RSZ400	BGZ400	PBZ400
RDTK10	444747	444699	RSZ400	BGZ400	PBZ400
RDTK20	444747	444700	RSZ500	BGZ500	PBZ500
RDTK40	444747	444701	RSZ500	BGZ500	PBZ560
RDTK40	444747	444702	RSZ630	BGZ630	PBZ630
RDTK70	444747	444703	RSZ630	BGZ630	PBZ710
RDTK10	444747	444697	RSZ300	BGZ300	PBZ300
RDTK10	444747	444697	RSZ400	BGZ400	PBZ400
RDTK10	444747	444699	RSZ500	BGZ500	PBZ500
RDTK10	444747	444699	RSZ500	BGZ500	PBZ560
RDTK20	444747	444700	RSZ630	BGZ630	PBZ630
RDTK40	444747	444702	RSZ630	BGZ630	PBZ710
RDTK40	444747	444702	-	INCL	PBZ800
-	444748	444706	-	INCL	PBZ1000
RDTK10	444747	444699	RSZ630	BGZ630	PBZ630
RDTK20	444747	444700	RSZ630	BGZ630	PBZ710
RDTK20	444747	444701	-	INCL	PBZ800

Note:

- The Standard roof cowl colour is BS 00A 05 (Goose Wing Grey) for all special B.S. or RAL colours contact Vent-Axia.
- When speed control is required a 5 step auto transformer speed controller is recommended, to ensure low noise levels.
- All 3 phase models are suitable for frequency inverter speed control.
- Vent-Axia only recommend using Inverters with integral Sine Filters for reliable operation.

NEW Quiet Pack (QP)

Features & Benefits

- 'O' Class rated acoustically treated casing, ensuring minimum duct and breakout noise levels
- Air volumes up to 1.59m³/s
- Suitable for external pressures up to 500Pa
- Designed to suit duct diameters from 100 to 500mm
- Operating Temperatures from -15°C up to +40°C
- Speed Controllable
- Quality Assurance to BS EN ISO 9001:1994
- Performance tested to BS848 Part 1 1980



The Quiet Pack in-line acoustic fans shall be as supplied from Roof Units, designed around a high performance centrifugal impeller, offering a highly efficient, quiet and compact in-line acoustic fan.

The Quiet Pack fan range is manufactured from prime quality galvanised sheet steel, ensuring a robust in-line fan for those tough site conditions.

Quiet Pack casings are suitable for internal mounting only and internally treated with an 'O' class rated acoustic foam, which offers the benefits of excellent low level duct bound and breakout sound levels, in addition self extinguishing properties, zero burn rate, resistant to ignition, and no toxic fumes.

Quiet Pack fans are suitable for circular ducting ranging in sizes 100, 125, 150, 160, 200, 250, 315, 400 and 500mm, with air volumes from 0.016m³/s to 1.8m³/s and pressure development of up to 500Pa.

The casing are specially designed to allow the unit to be mounted via drop rods or anti vibration mounts, ensuring a quick and easy solution to installation of the Quiet Pack in-line acoustic fans. All manufacturing progressed of the Quiet Pack fan units are computer designed and controlled to BS EN ISO 9001 Standards.

Impellers

The motor and backward curved impeller shall be factory matched, statically and dynamically balanced on precision machines, to DIN ISO 1940 Grade 6.3, to give quiet, vibration free running.

Motors

Motor insulation Class B, suitable for operating temperatures from -15°C to +40°C and atmospheres up to 95% RH.

All sizes are ideally suitable for speed control by electronic or voltage reduction. Vent-Axia would recommend that a voltage reduction Auto Transformer speed controller is used with all Quiet Pack units to ensure minimum noise levels during speed control and to eliminate any possibility of harmonic noise levels which may occur when using electronic speed controllers at lower speeds.

Performance

The fan performance, shall be in accordance with tests to BS848 Part 1 1980, with the fan sound levels, measured in a reverberant chamber in accordance with BS848 Part 2 1985.

Quality Assurance

Design and manufacture shall be in accordance with the standard for quality management systems BS EN ISO 9001:1994.

Accessories

A full range of accessories are available with the Fan Box range of fans such as:

- Auto Transformer Speed Controllers
- Electronic Speed Controllers
- D.O.L. Starters
- Standard, Acoustic & Thermal Flexible Ducting
- Pre-Panel or Secondary Bag Filters
- Electric Heater Batteries
- Backdraught Shutters
- In-Line Attenuators
- Wall & Roof Terminals
- Fast Clamps

Dimensions (mm)

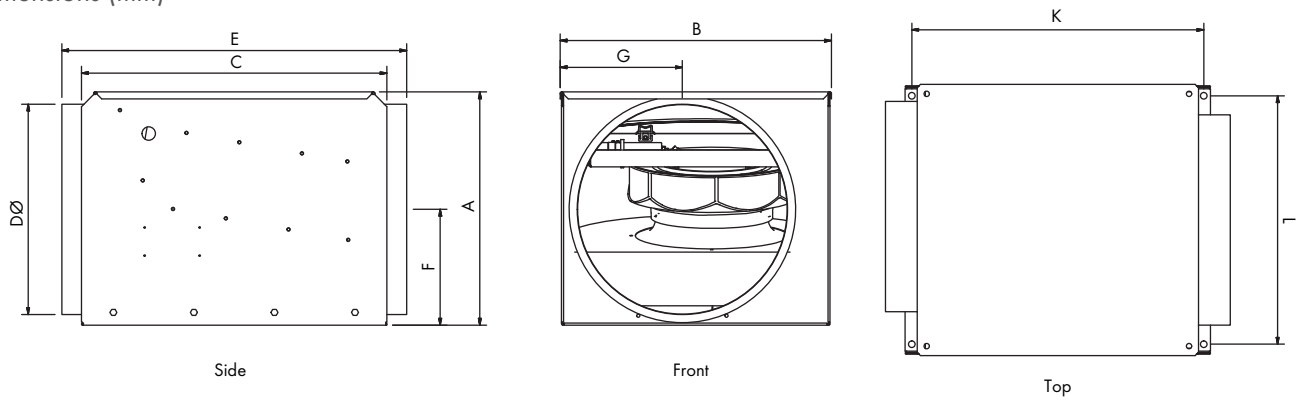

Stock Ref	A	B	C	ØD	E	F	G	K	L
QP100C	190	310	400	100	460	94	111	380	275
QP125C	190	310	400	125	460	94	111	380	275
QP150C	190	310	400	150	460	94	111	380	275
QP160C	190	310	400	160	460	94	111	380	275
QP200C	285	364	455	200	515	141	127	435	330
QP250C	285	364	455	250	515	141	127	435	330
QP315C	456	572	730	315	792	227	243	710	540
QP400C	456	572	730	400	792	227	243	710	540
QP500C	575	769	918	500	1006	286	326	898	735

Anti Vibration Mountings

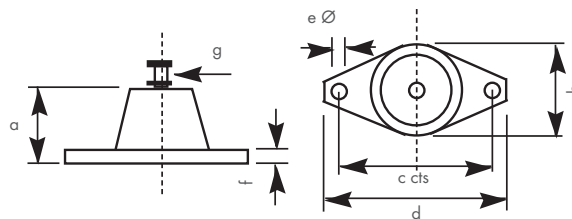

Stock Ref	a	b	c	d	eØ	f	g
68MP033G	27	37	54	67	7	3	M8

Performance Curves

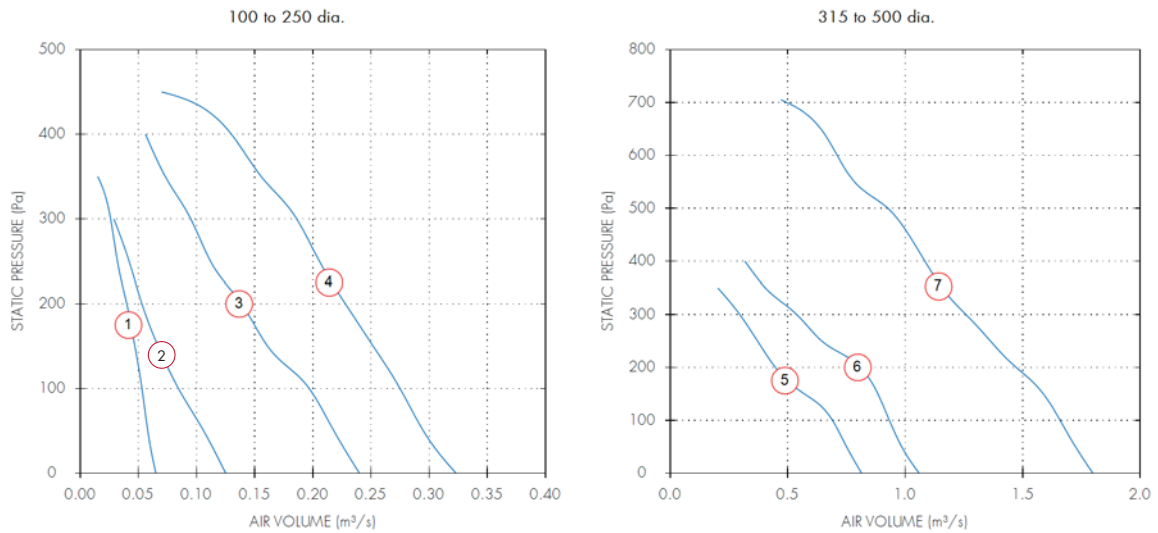

Performance Guide

Dia.	Motor Phase	Stock Ref	r.p.m	Curve Ref.	m³/s @ Pa					Motor kW	S.C. Amps	F.L.C Amps	dBA @ 3m
					0	100	200	300	400				
100	1	QP100C	2350	1	0.06	0.05	0.04	0.03		0.05	0.37	0.23	32
125	1	QP125C	2350	1	0.07	0.05	0.04	0.02		0.05	0.37	0.23	33
150	1	QP150C	2350	2	0.12	0.08	0.05	0.03		0.05	0.37	0.23	33
160	1	QP160C	2350	2	0.12	0.08	0.05	0.03		0.05	0.37	0.23	33
200	1	QP200C	2700	3	0.24	0.2	0.14	0.09	0.06	0.09	0.85	0.38	36
250	1	QP250C	2500	4	0.32	0.27	0.23	0.19	0.13	0.16	1.25	0.68	36
315	1	QP315C	1330	5	0.81	0.69	0.45	0.3		0.27	2.2	1.18	38
400	1	QP400C	1340	6	1.06	0.93	0.81	0.54	0.32	0.47	5.9	2.33	39
500	1	QP500C	1330	7	1.8	1.66	1.47	1.26	1.08	0.73	6.27	3.21	47

Sound Power Level Spectra dB (ref 10⁻¹² Watts)

Dia.	Motor Phase	Stock Ref	Spectrum	63	125	250	500	1k	2k	4k	8k	dBA @ 3m
100	1	QP100C	Inlet	53	59	68	58	50	45	34	33	41
100	1	QP100C	Outlet	54	57	63	59	60	54	49	42	43
100	1	QP100C	Breakout	48	52	59	49	41	39	31	32	32
125	1	QP125C	Inlet	51	65	73	62	51	46	36	36	45
125	1	QP125C	Outlet	52	62	67	64	62	55	52	45	46
125	1	QP125C	Breakout	51	53	60	49	41	40	33	33	33
150	1	QP150C	Inlet	54	60	70	59	52	46	38	36	42
150	1	QP150C	Outlet	56	58	63	58	59	56	49	43	43
150	1	QP150C	Breakout	50	55	60	50	43	38	31	32	33
160	1	QP160C	Inlet	54	60	70	59	52	46	38	36	42
160	1	QP160C	Outlet	56	58	63	58	59	56	49	43	43
160	1	QP160C	Breakout	50	55	60	50	43	38	31	32	33
200	1	QP200C	Inlet	60	65	63	68	58	55	54	46	46
200	1	QP200C	Outlet	60	63	68	72	68	67	62	53	53
200	1	QP200C	Breakout	54	58	60	57	46	41	35	34	36
250	1	QP250C	Inlet	64	74	72	67	57	55	56	53	48
250	1	QP250C	Outlet	64	74	75	69	70	71	65	64	56
250	1	QP250C	Breakout	52	57	68	52	44	40	36	38	39
315	1	QP315C	Inlet	66	78	68	60	52	49	42	40	45
315	1	QP315C	Outlet	67	75	77	71	69	62	56	49	53
315	1	QP315C	Breakout	54	70	63	53	47	41	35	34	38
400	1	QP400C	Inlet	73	82	79	68	62	55	50	49	52
400	1	QP400C	Outlet	72	78	78	75	74	66	58	53	57
400	1	QP400C	Breakout	57	71	63	56	51	46	39	35	39
500	1	QP500C	Inlet	77	85	78	71	64	62	54	52	54
500	1	QP500C	Outlet	74	83	82	78	77	72	64	58	61
500	1	QP500C	Breakout	68	81	72	63	56	49	42	41	48

Models & Accessories

Fan Stock Ref	Speed Controller			Overload Stock Ref	Anti Vibration Mounts (set of 4) Stock Ref
	Electronic Stock Ref	Auto Transfor.	Starter Stock Ref		
QP100C	SP5001	SPM5020	444744	444699	68MP033G
QP125C	SP5001	SPM5020	444744	444699	68MP033G
QP150C	SP5001	SPM5020	444744	444699	68MP033G
QP160C	SP5001	SPM5020	444744	444699	68MP033G
QP200C	SP5001	SPM5020	444744	444699	68MP033G
QP250C	SP5001	SPM5020	444744	444699	68MP033G
QP315C	SP5025	SPM5035	444744	444699	68MP033G
QP400C	SP5050	SPM5035	444744	444699	68MP033G
QP500C	SP5050	SPM5060	444744	444171	68MP033G

Fan Stock Ref	Electric Heaters Stock Ref		Panel Filters Stock Ref	Bag Filters Stock Ref
	QP100C	10531100T1		
QP125C	10531125T1	QPF125A	QPFB125A	
QP150C	10531150T1	QPF150A	QPFB150A	
QP160C	-	QPF160A	QPFB160A	
QP205C	10531200T1	QPF200A	QPFB200A	
QP250C	10531250T1	QPF250A	QPFB250A	
QP315C	10531315T1	QPF315A	QPFB315A	
QP400C	10531400T3	QPF400A	QPFB400A	
QP500C	10531500T3	QPF500A	QPFB500A	

Fan Stock Ref	In-line Attenuators				Wall Terminal Stock Ref
	300mm Stock Ref	600mm Stock Ref	900mm Stock Ref	1200mm Stock Ref	
QP100C	83010030	83010060	83010090	-	SA100/280
QP125C	83012030	83012060	83012090	-	SA125/280
QP150C	83015030	83015060	83015090	-	SA150/280
QP160C	83016030	83016060	83016090	-	SA150/280
QP205C	-	83020060	83020090	83020120	SA200/280
QP250C	-	83025060	83025090	83025120	SA250/280
QP315C	-	83031060	83031090	83031120	SA315/280
QP400C	-	83040060	83040090	83040120	QSA400/280
QP500C	-	83050060	83050090	83050120	-

NEW Quiet Pack Twin Fan (QPTW)

Features & Benefits

- Air volumes up to 1.35m³/s
- Suitable for external pressures up to 450Pa
- Designed to suit duct diameters from 100 to 500mm
- Operating temperatures up to 40°C
- Speed controllable
- Quality assurance to BS EN ISO 9001:1994
- Performance tested to BS848 Part 1 1980



The all new Quiet Pack Twin in-line fans shall be as supplied from Roof Units, designed around a high performance centrifugal impeller, offering a highly efficient, quiet and compact twin in-line acoustic fan.

The Quiet Pack Twin fan range is manufactured from prime quality galvanised sheet steel, ensuring a robust twin in-line fan for those tough site conditions.

Casings are suitable for internal mounting only and internally treated with an 'O' class rated acoustic foam, which offers the benefits of excellent low level duct bound and breakout sound levels, in addition self extinguishing properties, zero burn rate, resistant to ignition, and no toxic fumes.

Quiet Pack Twin fans are suitable for circular ducting ranging in sizes 100, 125, 150, 160, 200, 250, 315, 400 and 500mm, with air volumes up to 1.35m³/s and pressure development of up to 450Pa.

They are specially designed to allow the unit to be mounted via drop rods or anti vibration mounts, ensuring a quick and easy solution to installation with all units fitted with backdraught shutters to prevent air flow returning back through the system during shutdown periods.

Impellers

The motor and backward curved impeller is factory matched, statically and dynamically balanced on precision machines, to ISO 1940 Grade 6.3., to give quiet, vibration free running.

Motors

Motor insulation Class B, suitable for operating temperatures from -15°C up to +40°C and atmospheres up to 95% RH.

All sizes are suitable for speed control by electronic or voltage reduction. Vent-Axia would recommend that a voltage reduction Auto Transformer speed controller is used with all units to ensure minimum noise levels during speed control and to eliminate any possibility of harmonic noise levels which may occur when using electronic speed controllers at lower speeds.

Performance

The fan performance, shall be in accordance with tests to BS848 Part 1 1980, with the fan sound levels, measured in a reverberant chamber in accordance with BS848 Part 2 1985.

Quality Assurance

Design and manufacture shall be in accordance with the standard for quality management systems BS EN ISO 9001:1994.

Accessories

A full range of accessories are available to compliment the range of fans such as:

- Manual/Auto Changeover Twin Fan Controllers
 - Auto Transformer Speed Controllers
 - Electronic Speed Controllers
 - D.O.L. Starters
 - Standard, Acoustic & Thermal Flexible Ducting
 - In-Line Attenuators
 - Wall & Roof Terminals
 - Fast Clamps
-

ACOB1A Twin Fan Controller



Operating temperature: 0°C to +40°C.

IP rating: IP40.

Fuse Size: T rated 15 amp glass fuse (5x20mm).

Models

Stock Ref

ACOB1A

Features & Benefits

- Manual or auto changeover facilities
- 2 to 24 hour adjustable duty sharing
- Diagnostic program facility on start up
- Suitable for 1 phase twin fan units up to 8 amps
- Can be wired in conjunction with speed controllers
- Volt free contacts fitted as standard
- Neon failure indicators

Specification

Supply Voltage: 230 to 240V/1ph/50Hz.

Maximum Current Capacity: 0.1 to 8.0 amps.

Dimensions (mm)

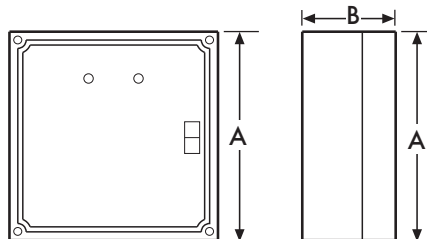

Size	A	B	Kg
ACOB1A	125	56	0.28

Dimensions (mm)

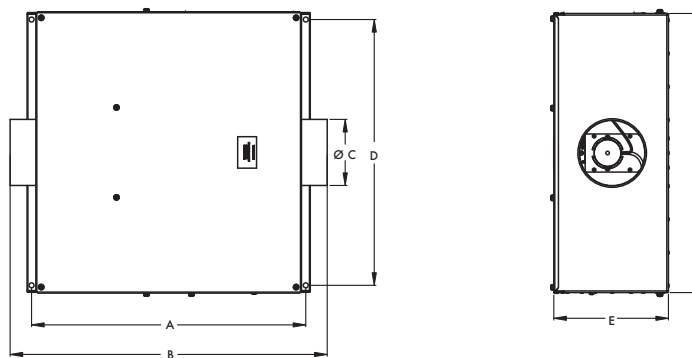

Stock Ref	Duct Diameter mm				Weight		
	A	B	ØC	D			
QPTW100C	610	705	100	591	256	622	26
QPTW125C	610	705	125	591	256	622	26
QPTW150C	610	705	150	591	256	622	26
QPTW200C	801	896	200	703	343	734	39
QPTW250C	925	1020	250	798	354	829	48
QPTW315C	1255	1353	315	1145	536	1176	88
QPTW400C	1255	1353	400	1145	536	1176	90
QPTW500C	1492	1590	500	1533	675	1564	175

Anti Vibration Mountings

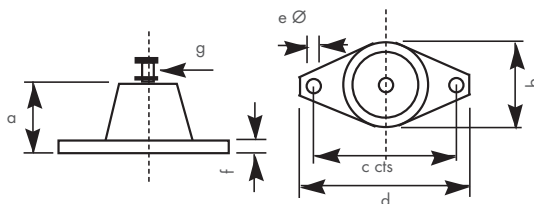

Stock ref	a	b	c	d	eØ	f	g
68MP033G	27	37	54	67	7	3	M8

Performance Curves

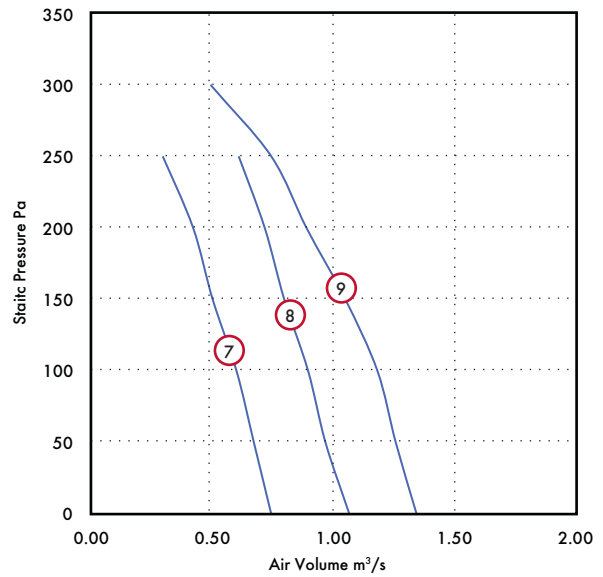
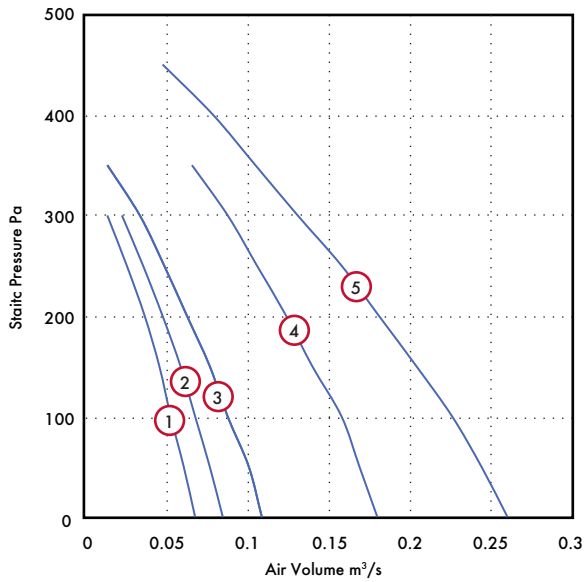

Performance Guide

Stock Ref	rpm	Phase	Curve Ref	Duty m³/s @ Pa										Motor kW	S.C. Amps	F.LC Amps	dBa @ 3m	
				0	50	100	150	200	250	300	350	400	450					
QPTW100C	2450	1	1	0.068	0.061	0.053	0.046	0.037	0.026	0.014					0.05	0.37	0.23	32
QPTW125C	2450	1	2	0.085	0.077	0.068	0.059	0.048	0.036	0.023					0.05	0.37	0.23	33
QPTW150C	2450	1	3	0.109	0.101	0.088	0.077	0.063	0.049	0.034	0.014				0.05	0.37	0.23	33
QPTW160C	2700	1	3	0.109	0.101	0.088	0.077	0.063	0.049	0.034	0.014				0.05	0.37	0.23	33
QPTW200C	2400	1	4	0.180	0.169	0.158	0.140	0.124	0.106	0.088	0.066				0.09	0.85	0.38	36
QPTW250C	2550	1	5	0.260	0.244	0.226	0.204	0.181	0.158	0.131	0.105	0.079	0.048		0.16	1.25	0.68	36
QPTW315C	1330	1	6	0.747	0.675	0.603	0.504	0.423	0.297						0.27	2.2	1.18	38
QPTW400C	1340	1	7	1.071	0.972	0.9	0.801	0.72	0.612						0.47	5.9	2.33	39
QPTW500C	1330	1	8	1.35	1.263	1.187	1.054	0.890	0.747	0.495					0.73	6.27	3.21	47

FLC = Full Load Current SC = Starting Current

Sound Power Level Spectra dB (ref 10⁻¹² Watts)

Dia.	Motor Phase	Stock Ref	Spectrum	63	125	250	500	1k	2k	4k	8k	dBa @ 3m
100	1	QPTW100C	Inlet	53	59	68	58	50	45	34	33	41
100	1	QPTW100C	Outlet	54	57	63	59	60	54	49	42	43
100	1	QPTW100C	Breakout	48	52	59	49	41	39	31	32	32
125	1	QPTW125C	Inlet	51	65	73	62	51	46	36	36	45
125	1	QPTW125C	Outlet	52	62	67	64	62	55	52	45	46
125	1	QPTW125C	Breakout	51	53	60	49	41	40	33	33	33
150	1	QPTW150C	Inlet	54	60	70	59	52	46	38	36	42
150	1	QPTW150C	Outlet	56	58	63	58	59	56	49	43	43
150	1	QPTW150C	Breakout	50	55	60	50	43	38	31	32	33
160	1	QPTW160C	Inlet	54	60	70	59	52	46	38	36	42
160	1	QPTW160C	Outlet	56	58	63	58	59	56	49	43	43
160	1	QPTW160C	Breakout	50	55	60	50	43	38	31	32	33
200	1	QPTW200C	Inlet	60	65	63	68	58	55	54	46	46
200	1	QPTW200C	Outlet	60	63	68	72	68	67	62	53	53
200	1	QPTW200C	Breakout	54	58	60	57	46	41	35	34	36
250	1	QPTW250C	Inlet	64	74	72	67	57	55	56	53	48
250	1	QPTW250C	Outlet	64	74	75	69	70	71	65	64	56
250	1	QPTW250C	Breakout	52	57	68	52	44	40	36	38	39
315	1	QPTW315C	Inlet	66	78	68	60	52	49	42	40	45
315	1	QPTW315C	Outlet	67	75	77	71	69	62	56	49	53
315	1	QPTW315C	Breakout	54	70	63	53	47	41	35	34	38
400	1	QPTW400C	Inlet	73	82	79	68	62	55	50	49	52
400	1	QPTW400C	Outlet	72	78	78	75	74	66	58	53	57
400	1	QPTW400C	Breakout	57	71	63	56	51	46	39	35	39
500	1	QPTW500C	Inlet	77	85	78	71	64	62	54	52	54
500	1	QPTW500C	Outlet	74	83	82	78	77	72	64	58	61
500	1	QPTW500C	Breakout	68	81	72	63	56	49	42	41	48

Models & Accessories

Fan Stock Ref	Auto Changeover Controller Stock Ref	Speed Controller	
		Electronic 1ph Stock Ref	Auto Transformer Stock Ref
QPTW100C	ACOB1A	SP5001	SPM5020
QPTW125C	ACOB1A	SP5001	SPM5020
QPTW150C	ACOB1A	SP5001	SPM5020
QPTW160C	ACOB1A	SP5001	SPM5020
QPTW200C	ACOB1A	SP5001	SPM5020
QPTW250C	ACOB1A	SP5025	SPM5035
QPTW315C	ACOB1A	SP5050	SPM5060
QPTW400C	ACOB1A	SP5050	SPM5060
QPTW500C	ACOB1A	SP5050	SPM5060

Fan Stock Ref	In-line Attenuators			
	300mm Stock Ref	600mm Stock Ref	900mm Stock Ref	1200mm Stock Ref
QPTW100C	83010030	83010060	83010090	-
QPTW125C	83012030	83012060	83012090	-
QPTW150C	83015030	83015060	83015090	-
QPTW160C	-	83016060	83016090	-
QPTW200C	-	83020060	83020090	83020120
QPTW250C	-	83025060	83025090	83025120
QPTW315C	-	83031060	83031090	83031120
QPTW400C	-	-	83040090	83040120
QPTW500C	-	-	83050090	83050120

Fan Stock Ref	Anti Vibration Mounts Stock Ref	Intumescent Fire Dampers Stock Ref	Wall Terminal Stock Ref	Roof Terminal Stock Ref
QPTW125C	68MP033G	CVT130	SA125/280	WB160
QPTW150C	68MP033G	CVT150	SA150/280	WB160
QPTW160C	68MP033G	-	SA150/280	WB200
QPTW200C	68MP033G	CVT200	SA200/280	WB200
QPTW250C	68MP033G	CVT250	SA250/280	WB200
QPTW315C	68MP033G	CVT300	SA315/280	RCZ300
QPTW400C	68MP033G	-	QSA400/280	RCZ400
QPTW500C	68MP133G	-	-	RCZ500

Slimpak (SLP)

Features & Benefits

- Ultra slim and compact
- Acoustically treated 'O' class rated
- 'Eco Flow' computer modelled design
- Latest external rotor motor
- Fully speed controllable
- Matching ancillaries



The Slimpak in-line acoustic fans shall be as supplied from Roof Units. Manufactured from prime quality galvanised sheet steel, ensuring a robust in-line fan for those tough site conditions. Slimpak shall be internally treated with an 'O' class rated acoustic foam, which offers the benefits of excellent low level duct bound and breakout sound levels, in addition self extinguishing properties, zero burn role, resistant to ignition, and no toxic fumes.

Slimpak fans are to be suitable for circular ducting ranging in sizes 100, 125, 150, 200, 250 and 315mm with air volumes from 0.075m³/s to 0.380m³/s and pressure development of up to 550Pa.

The casing shall be specially designed to allow the unit to be mounted quickly and easily. All manufacturing progressed of the Slimpak fan units are computer designed and controlled to BS EN ISO 9001 Standards.

Impellers

The backward curved centrifugal impellers shall be aerodynamically designed, utilising computer technology combining the impeller with the external rotor motor. The motor and impeller shall be factory matched, statically and dynamically balanced on precision machines, to DIN ISO1940 Grade 6.3, to give quiet, vibration free running. The aerodynamic blades and motor housing shall be manufactured from prime quality galvanised sheet steel.

Motors

All sizes from 100 to 315 shall be protected to IP44 in accordance with BS EN 60529:1992. With motor insulation Class B, suitable for operating temperatures from -15°C and atmospheres up to 95% RH. The range shall incorporate maintenance free external rotor motors, fitted with sealed for life ball bearings.

All sizes are ideally suitable for speed control by electronic or voltage reduction. Vent-Axia would recommend that a voltage reduction Auto Transformer speed controller is used with all Slimpak units to ensure

minimum noise levels during speed control and to eliminate any possibility of harmonic noise levels which occur when using electronic speed controllers at lower levels.

Terminal Box

An IP54 terminal box shall be supplied with all models with 20mm cable gland entry.

Performance

The fan performance, shall be in accordance with tests to BS848 Part 1 1980, with the fan sound levels, measured in a reverberant chamber in accordance with BS848 Part 2 1985.

Quality Assurance

Design and manufacture shall be in accordance with the standard for quality management systems BS EN ISO 9001:1994.

Accessories

A full range of accessories are available with the Slimpak range of fans such as:

- Auto Transformer Speed Controllers
- Electronic Speed Controllers
- D.O.L. Starters
- Pre & Secondary Filter Cassettes
- Electric Heater Batteries
- Backdraught Shutters
- In-Line Attenuators
- Wall & Roof Terminals
- Fast Clamps

Dimensions (mm)

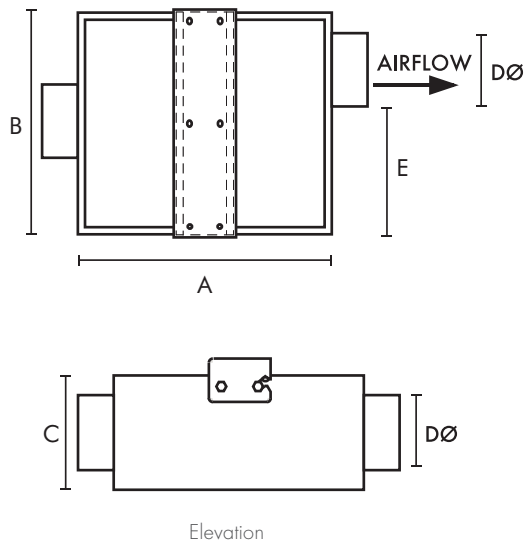

Fan Stock Ref	A	B	C	DØ	E	Weight kg
SLP100	360	306	160	100	178	8
SLP125	360	306	160	125	165	8
SLP150	360	306	180	150	140	9
SLP200	415	360	285	200	140	13
SLP250	415	360	285	250	90	15
SLP315	450	400	350	315	65	17

Mounting bracket (mm)

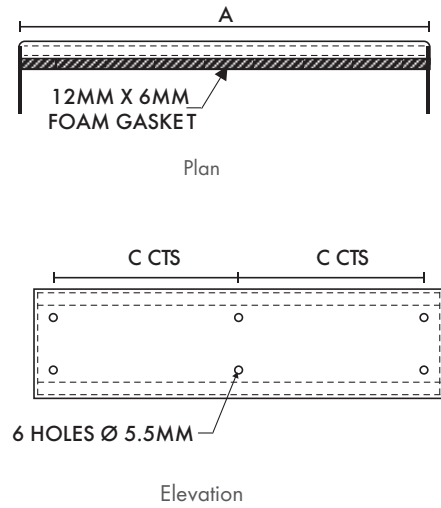

Fan Stock Ref	A	B	C
SLP100	306	80	138
SLP125	306	80	138
SLP150	306	80	138
SLP200	360	130	165
SLP250	360	130	165
SLP315	400	180	184.5

Performance Curves

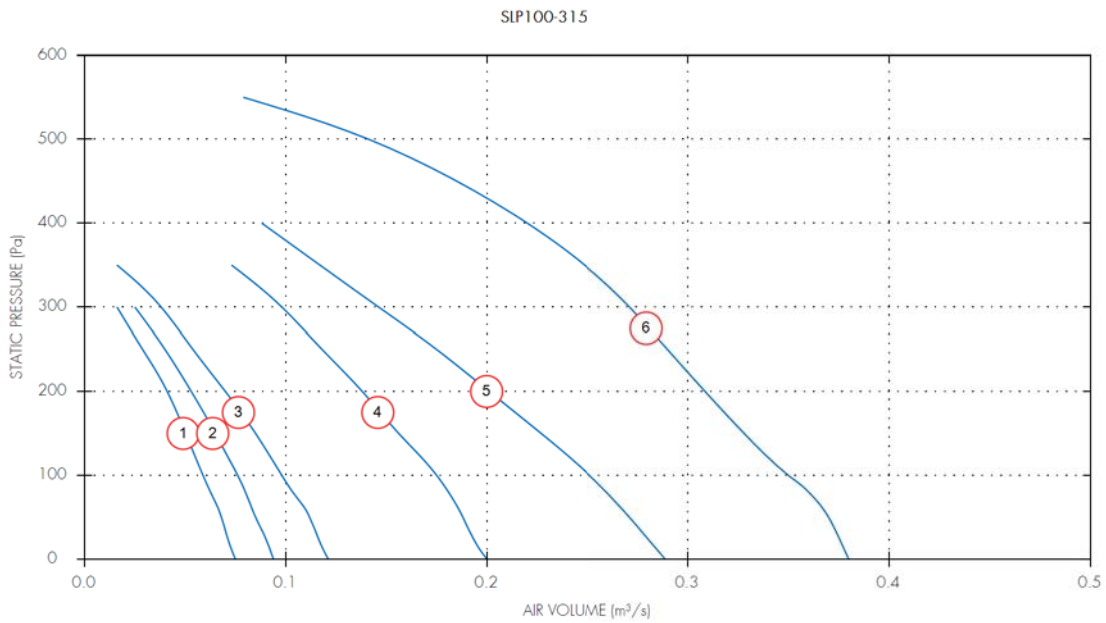

Performance Guide

Dia.	Motor Phase	Stock Ref	r.p.m	IP Rating	Curve Ref.	m³/s @ Pa					Motor kW	S.C. Amps	F.L.C Amps	dBA @ 3m	
						0	100	200	300	400					500
100	1	SLP100	2450	IP44	1	0.08	0.06	0.04	0.02		0.06	1.04	0.26	30	
125	1	SLP125	2450	IP44	2	0.09	0.08	0.05	0.02		0.06	1.04	0.26	31	
150	1	SLP150	2450	IP44	3	0.12	0.1	0.07	0.04		0.06	1.04	0.26	41	
200	1	SLP200	2700	IP44	4	0.2	0.17	0.14	0.1		0.12	1.92	0.48	39	
250	1	SLP250	2400	IP44	5	0.29	0.25	0.2	0.15	0.09	0.21	3.6	0.9	43	
315	1	SLP315	2550	IP44	6	0.38	0.35	0.31	0.27	0.22	0.14	0.27	4.6	1.15	45

Sound Power Level Spectra dB (ref 10⁻¹² Watts)

Dia.	Motor Phase	Stock Ref	Spectrum	dB								dBA @ 3m
				63	125	250	500	1k	2k	4k	8k	
100	1	SLP100	Inlet	60	63	56	62	51	48	43	40	40
100	1	SLP100	Outlet	61	65	57	58	56	54	50	43	41
100	1	SLP100	Breakout	51	52	53	51	42	38	34	30	30
125	1	SLP125	Inlet	55	59	58	64	53	49	42	39	42
125	1	SLP125	Outlet	59	61	59	61	59	58	54	45	44
125	1	SLP125	Breakout	52	54	54	52	43	38	34	30	31
150	1	SLP150	Inlet	52	58	57	64	55	52	47	42	42
150	1	SLP150	Outlet	58	60	60	63	60	59	55	47	45
150	1	SLP150	Breakout	52	53	53	52	43	38	34	30	31
200	1	SLP200	Inlet	65	68	72	64	56	51	52	47	46
200	1	SLP200	Outlet	60	66	68	71	66	65	65	58	52
200	1	SLP200	Breakout	58	65	65	59	48	43	38	35	39
250	1	SLP250	Inlet	74	76	75	68	58	57	55	48	50
250	1	SLP250	Outlet	62	72	74	73	72	69	68	59	56
250	1	SLP250	Breakout	61	70	68	63	54	47	43	32	43
315	1	SLP315	Inlet	71	75	74	70	70	66	63	58	54
315	1	SLP315	Outlet	62	70	76	78	72	71	70	63	59
315	1	SLP315	Breakout	61	69	70	64	58	52	46	37	45

Models & Accessories

Fan Stock Ref	Speed Controller					Electric Heaters Stock Ref
	Electronic	Auto Transfor.	Starter	Overload		
	Stock Ref	Stock Ref	Stock Ref	Stock Ref	Stock Ref	
SLP100	SP5001	SPM5020	444744	444699	10531100T1	
SLP125	SP5001	SPM5020	444744	444699	10531125T1	
SLP150	SP5001	SPM5020	444744	444699	10531150T1	
SLP200	SP5001	SPM5020	444744	444699	10531200T1	
SLP250	SP5001	SPM5020	444744	444700	10531250T1	
SLP315	SP5001	SPM5020	444744	444702	10531315T1	

Fan Stock Ref	Attenuators			Wall Terminal Stock Ref
	Inlet	Discharge		
	Stock Ref	Stock Ref	Stock Ref	
SLP100	SLSI100/1	SLSD100/1	SA100/280	
SLP125	SLSI125/1	SLSD125/1	SA125/280	
SLP150	SLSI150/1	SLSD150/1	SA150/280	
SLP200	SLSI200/1	SLSD200/1	SA200/280	
SLP250	SLSI250/1	SLSD250/1	SA250/280	
SLP315	SLSI315/1	SLSD315/1	SA315/280	

Fan Stock Ref	Roof Terminal Stock Ref	Louvre	Flexible	Panel Filters Stock Ref	Back Draught
		Shutter	Connections		Shutters
		Stock Ref	Stock Ref		Stock Ref
SLP100	WRC100	LS250	FLX100	SLPF100	BDS100
SLP125	WB160C	LS250	FLX125	SLPF125	BDS125
SLP150	WB160C	LS315	FLX150	SLPF150	BDS150
SLP200	WB200C	LS315	FLX200	SLPF200	BDS200
SLP250	WB200C	LS315	FLX250	SLPF250	BDS250
SLP315	RCZ300	LS400	FLX315	SLPF315	BDS315

Slimpak (SLPT)

Features & Benefits

- Motor Insulation Class B, protected to IP44
- All units suitable for speed control
- Quality Assurance to BS EN ISO 9001:1994
- Performance tested to BS848 Part 1 1980
- Units suitable as a run & standby extract fan or simultaneously running fan

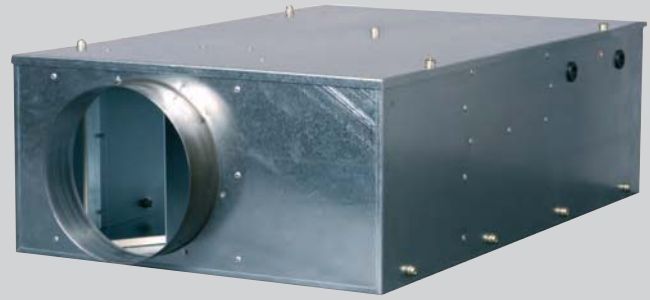

The Slimpak range of streamline twin fan units, which have been designed to allow the unit to be installed as a Run & Standby extract fan.

Slimpak housings are manufactured from prime quality galvanised sheet steel with circular inlet and outlet spigot connections. To ensure minimum noise levels the units casing is treated with an acoustic lining, Class O rated which offers self extinguishing, zero burn rate, resists ignition and no toxic fume properties.

Each unit incorporates a back draught shutter to prevent air recirculation via the standby fan and to ensure easy access for cleaning and maintenance purposes a full sized access panel is provided to both fans.

Designed and developed to provide one of the most powerful and compact twins in the market, available in three sizes 200, 250 and 315mm dia, with extract performance ranging from 0.116m³/s up to 0.400m³/s (417m³/h to 1,440m³/h), with pressure characteristics of up 550Pa.

Motors

At the heart of the range is a proven 230V/1/50Hz external rotor motor and backward curved impeller assembly. The assembly is dynamically balanced to ISO 1940. Motors are rated to IP44 according to BS EN 60529. Ball bearings are greased for life and allow the fan to run at any angle. Insulation is Class 'B' (from -15°C to +40°C).

All Acoustic fans are suitable for speed control, an Auto Transformer is recommended to ensure minimum noise levels during speed control so eliminating any possibility of motor harmonic noise.

Performance and Sound

Tested to BS 848 Parts 1 & 2. Published dB(A) figures are free field sound pressure levels at 3m with spherical propagation at a reference level of 2 x 10⁻⁵ Pa (20 micro-Pascal). The inlet, outlet and breakout sound power level spectra figures are dB with a reference of 10-12 Watts (1 pico-watt).

Quality Assurance

Design and manufacture shall be in accordance with BS EN ISO 9001:1994.

Dimensions (mm)

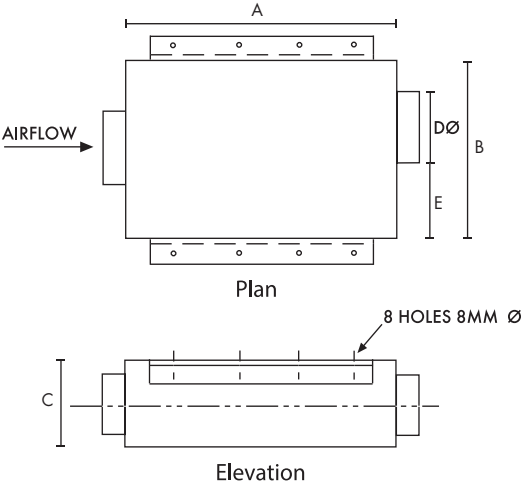

Unit	A	B	C	DØ	E	Weight
DuctØ						kg
200	760	490	235	200	205	20
250	865	590	285	250	233	32
315	955	650	350	315	240	39

Performance Curves

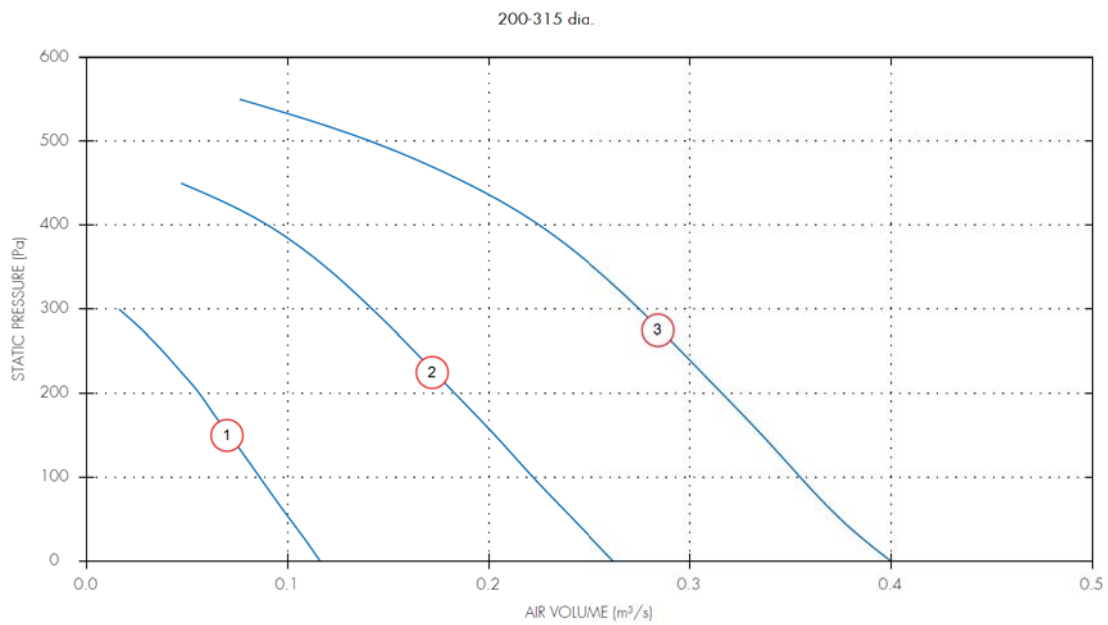

Performance Guide

Dia.	Motor Phase	Stock Ref	Poles	r.p.m	IP Rating	Curve Ref.	m³/s @ Pa					Motor kW	S.C. Amps	F.L.C Amps	dBA @ 3m	
							0	100	200	300	400					500
200	1	SLPT200	2	2450	IP44	1	0.12	0.09	0.06	0.02		0.09	1.44	0.36	31	
250	1	SLPT250	2	2400	IP44	2	0.26	0.22	0.18	0.14	0.09	0.21	3.6	0.9	43	
315	1	SLPT315	2	2550	IP44	3	0.4	0.36	0.32	0.27	0.22	0.14	0.27	4.6	1.15	45

Sound Power Level Spectra dB (ref 10⁻¹² Watts)

Dia.	Motor Phase	Stock Ref	Poles	Spectrum	dB								dBA @ 3m
					63	125	250	500	1k	2k	4k	8k	
200	1	SLPT200	2	Inlet	55	60	61	62	55	51	49	41	41
200	1	SLPT200	2	Outlet	53	59	60	62	61	57	54	43	44
200	1	SLPT200	2	Breakout	52	53	53	52	43	38	34	30	31
250	1	SLPT250	2	Inlet	74	76	75	68	58	57	55	48	50
250	1	SLPT250	2	Outlet	62	72	74	73	72	69	68	59	56
250	1	SLPT250	2	Breakout	61	70	68	63	54	47	43	32	43
315	1	SLPT315	2	Inlet	71	75	74	70	70	66	63	58	54
315	1	SLPT315	2	Outlet	62	70	76	78	72	71	70	63	59
315	1	SLPT315	2	Breakout	61	69	70	64	58	52	46	37	45

Models & Accessories

Fan	ITC Man/Auto Changeover Controller	ITC-DS12/24hr Auto Changeover Controller	RVC ELV Remote Visual Indicator	Auto Transformer
Stock Ref	Stock Ref	Stock Ref	Stock Ref	Stock Ref
SLPT200	10314200	10314210	10314220	10314103
SLPT250	10314200	10314210	10314220	10314103
SLPT315	10314200	10314210	10314220	10314103

Electronic Speed Controller	Auto Transformer & Coil	Starter	Overload	Flexible Connection	Anti-Vibration Mounts (set of 4)	
Size	Stock Ref	Stock Ref	Stock Ref	Stock Ref	Stock Ref	
200mm	W10303102M	10314103	444744	444698	FLX200	68MP033G
250mm	W10303102M	10314103	444744	444700	FLX250	68MP033G
315mm	W10303102M	10314103	444744	444700	FLX315	68MP033G

Heat Exchange Unit	Backdraught Shutter	Fast Clamp	Worm Drive Clips
Size	Stock Ref	Stock Ref	Stock Ref
200mm	10538290	-	-
	+10577315	10542200	10540200
	+10578315	-	-
250mm	10538290	-	-
	+10577315	10542250	10540250
	+10578315	-	-
315mm	10538290	-	-
	+10577315	10542315	10540315
			561710

Pre Filter Cassette	5 Spare Pre Filters	Bag Filter Cassette	Spare Bag Filter Each	3-Way Splitter	Duct Air Heater	
Size	Stock Ref	Stock Ref	Stock Ref	Stock Ref	Stock Ref	
200mm	10532200	10556200A	10533200	10557200	10551250	10531200T1
250mm	10532250	10556250A	10533250	10557250	10551250	10531250T1
315mm	10532315	10556315A	10533315	10557315	10553400	10531315T1

Duct Attenuator					
Size	600mm Stock Ref	900mm Stock Ref	1200mm Stock Ref	Joining Piece Stock Ref	Louvre Shutter Stock Ref
200mm	10535200	10536200	10537200	561808	LS200
250mm	10535250	10536250	10537250	561810	LS250
315mm	10535315	10536315	10537315	561813	LS315

EuroSeries (SDX)

Features & Benefits

- Available in sizes 100 to 315
- 200 and 250 sizes also available as high performance
- Motor Insulation Class B, protected to IP44
- Operating Temperatures from -25°C up to +60°C
- All units suitable for speed control
- Quality Assurance to BS EN ISO 9001:1994
- Performance tested to BS848 Part 1 1980
- 2 Year Warranty



The SDX Euroflow in-line centrifugal duct fans are designed around an efficient backward curved centrifugal impeller and external rotor motor to ensure a compact design, high performance and low sound levels.

The in-line fan casing is constructed from pressed steel and incorporates an aerodynamically designed airflow guide vane, ensuring maximum performance from the unit whilst maintaining minimum noise levels. All models are supplied with a simple mounting foot for ease of installation.

The SDX range is available in eight model sizes: 100, 125, 150, 200, 250 & 315mm diameter as standard performance and sizes 200 and 250 also available as a high performance in-line centrifugal duct fan. The range provides a performance up to 0.372m³/s with a maximum pressure development of 500 Pa.

The SDX range is suitable for the extract of clean air only. It is not suitable for extracting or transporting grinding dust, soot, explosive or other aggressive gases etc.

Impellers

The impellers are aerodynamically designed centrifugal backward curved type, manufactured by injection moulding of a polypropylene resin. The motor and impeller is factory matched, statically and dynamically balanced in two planes to ISO 1940, Grade G 6.3.

Motors

All units are fitted with motors protected to IP44, insulation Class B and are suitable for temperatures ranging from -25°C to +60°C with humidity levels of up to 95% RH ensuring reliable operation. All sizes are for a 220V/1/50Hz electrical supply and incorporate a manual reset thermal protection device.

Terminal Box

An IP54 terminal box fitted to the casing with multiple cable entry positions.

Performance

The fan performance is in accordance with tests to BS848 Part 1 1980, with the fan sound levels measured in a reverberant chamber in accordance with BS848 Part 2 1985.

Quality Assurance

Design and manufacture is in accordance with the standard for quality management systems BS EN ISO 9001:1994.

Accessories

A full range of accessories are available with the Euroflow in-line centrifugal duct fans such as:

- Electronic Speed Controllers
 - Auto Transformer Speed Controllers
 - D.O.L. Starter and Overload
 - Pre & Secondary Filter Cassettes
 - Electric Heater Batteries
 - In-Line Attenuators
 - Backdraught Shutters
 - Fast Clamps
 - Flexible Ducting
 - Wall Terminals
 - Roof Terminals
-

Dimensions (mm)

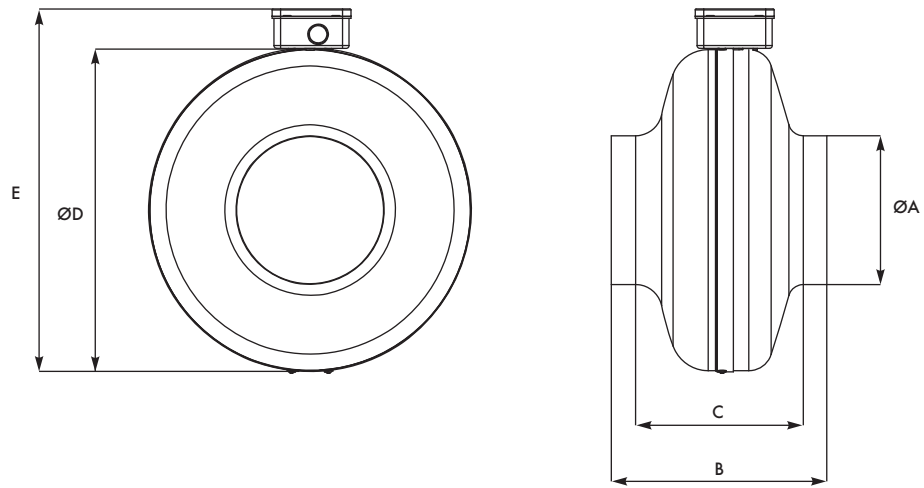

Unit Size	ØA	B	C	ØD	E	kg
SDX100	100	189	152	244	287	3
SDX125	125	182	143	243	286	3
SDX150	150	217	166	344	387	3
SDX200	200	219	167	344	387	4
SDX200H	200	231	179	344	387	4.7
SDX250	250	223	167	344	387	4
SDX250H	250	230	167	344	387	4.7
SDX315	315	243	175	402	444	5.6

Performance Curves

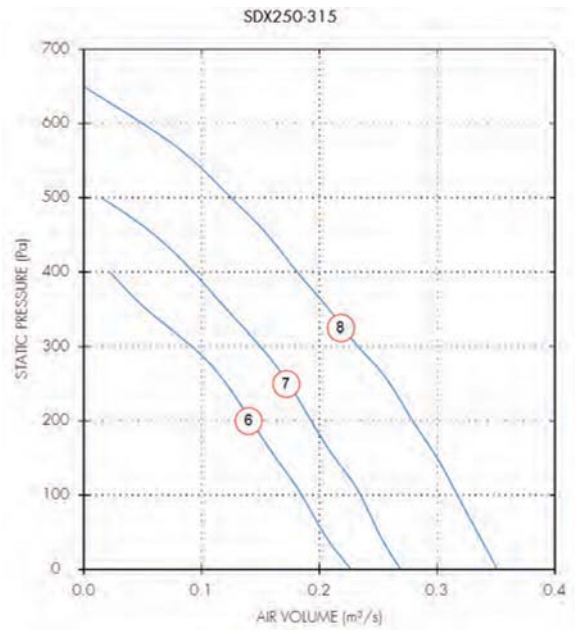
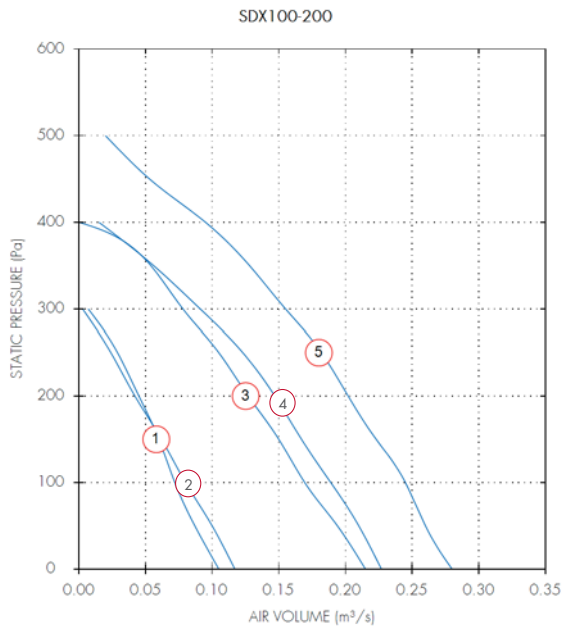

Performance Guide

Dia.	Motor Phase	Stock Ref	r.p.m	IP Rating	Curve Ref.	m³/s @ Pa						Motor kW	F.L.C Amps	dBA @ 3m	
						0	100	200	300	400	500				600
100	1	SDX100	2800	IP44	1	0.1	0.07	0.05	0.01				0.07	0.31	26
125	1	SDX125	2800	IP44	2	0.12	0.08	0.04	0				0.08	0.31	24
150	1	SDX150	2800	IP44	3	0.22	0.17	0.13	0.08	0			0.1	0.44	35
200	1	SDX200	2600	IP44	4	0.23	0.19	0.15	0.09	0.02			0.11	0.45	34
200	1	SDX200H	2660	IP44	5	0.28	0.24	0.2	0.16	0.09	0.02		0.14	0.56	38
250	1	SDX250	2600	IP44	6	0.23	0.18	0.14	0.09	0.02			0.11	0.45	31
250	1	SDX250H	2460	IP44	7	0.27	0.23	0.19	0.15	0.09	0.02		0.13	0.56	34
315	1	SDX315	2567	IP44	8	0.35	0.32	0.28	0.23	0.18	0.13	0.05	0.22	0.96	36

Sound Power Level Spectra dB (ref 10⁻¹² Watts)

Dia.	Motor Phase	Stock Ref	Spectrum	dB @ 3m							
				125	250	500	1k	2k	4k	8k	
100	1	SDX100	Inlet	53	58	60	66	65	58	47	49
100	1	SDX100	Outlet	54	60	61	67	66	58	48	50
100	1	SDX100	Breakout	34	58	44	55	54	47	37	39
125	1	SDX125	Inlet	50	54	63	65	64	56	47	48
125	1	SDX125	Outlet	49	53	61	64	63	55	45	47
125	1	SDX125	Breakout	28	29	45	53	52	44	35	36
150	1	SDX150	Inlet	51	66	67	71	62	61	53	52
150	1	SDX150	Outlet	52	67	68	72	64	63	50	54
150	1	SDX150	Breakout	30	49	51	60	52	50	36	41
200	1	SDX200	Inlet	46	53	62	66	63	64	54	50
200	1	SDX200	Outlet	45	54	61	68	64	65	53	51
200	1	SDX200	Breakout	22	24	41	49	53	43	40	35
200	1	SDX200H	Inlet	53	60	66	69	66	65	63	53
200	1	SDX200H	Outlet	54	62	65	70	67	67	63	54
200	1	SDX200H	Breakout	25	35	46	53	55	47	45	38
250	1	SDX250	Inlet	41	52	61	66	66	64	56	51
250	1	SDX250	Outlet	43	53	60	68	67	65	57	52
250	1	SDX250	Breakout	24	30	38	48	47	45	40	32
250	1	SDX250H	Inlet	54	62	67	69	67	67	65	54
250	1	SDX250H	Outlet	55	63	66	70	68	67	65	54
250	1	SDX250H	Breakout	33	38	47	50	48	47	46	34
315	1	SDX315	Inlet	50	59	67	68	66	65	64	52
315	1	SDX315	Outlet	51	60	66	69	67	66	65	53
315	1	SDX315	Breakout	33	38	45	48	47	45	43	32

Models & Accessories

Fan	Speed Controller		Starter (requires Overload)	Overload
Stock Ref	Stock Ref	Stock Ref	Stock Ref	Stock Ref
SDX100	SP5001	SPM5020	444744	444696
SDX125	SP5001	SPM5020	444744	444696
SDX150	SP5001	SPM5020	444744	444697
SDX200	SP5001	SPM5020	444744	444698
SDX200H	SP5001	SPM5020	444744	444699
SDX250	SP5001	SPM5020	444744	444698
SDX250H	SP5001	SPM5020	444744	444699
SDX315	SP5001	SPM5020	444744	444699

Dia	In-Line Attenuators			
	300mm Stock Ref	600mm Stock Ref	900mm Stock Ref	1200mm Stock Ref
100	83010030	83010060	83010090	-
125	83012030	83012060	83012090	-
150	83015030	83015060	83015090	-
200	-	83020060	83020090	83020120
250	-	83025060	83025090	83025120
315	-	83031060	83031090	83031120

Fan	Wall Terminal	Wall Terminal	Electric Heaters	Panel Filters
Stock Ref	Stock Ref	Stock Ref	Stock Ref	Stock Ref
100	SA100/280	SA100/80	10531100T1	QPF100A
125	SA125/280	SA125/80	10531125T1	QPF125A
150	SA150/280	SA150/80	10531150T1	QPF150A
200	SA200/280	SA200/80	10531200T1	QPF200A
250	SA250/280	SA250/80	10531250T1	QPF250A
315	SA315/280	SA315/80	10531315T1	QPF315A

Fan	Bag Filters	Roof Terminal	Louvre Shutter
Stock Ref	Stock Ref	Stock Ref	Stock Ref
100	QPFB100A	WRC100	LS250
125	QPFB125A	WB160	LS250
150	QPFB150A	WB160	LS250
200	QPFB200A	WB200	LS250
250	QPFB250A	RCZ300	LS250
315	QPFB315A	RCZ300	LS315

Speed Controllers

Single Phase SP & SPTK (Electronic)



Features & Benefits

- Single Phase, electronic, infinitely variable, stepless speed control with MIN/MAX preset facility
- Separate starter not required when used with HOT SPOT protected fan (SPTK only)
- Compact and easy to install
- Suitable for surface or flush mounting (SP5010 surface only)*
- SP type include ON/OFF switch with neon indicator
- SPTK type include ON/OFF/RESET switch and indication light fan trip indicator and built in facility for manual reset
- Complies with required statutory regulations and carries CE mark

Unit	*Max Peak	Dimensions	Weight	
Stock Ref	Load Current	H x W x D (mm)	kg	Enclosure
SP5001	1.7 amps	86 x 86 x 71	0.33	IP40
SP5025	3.0 amps	147 x 86.5 x 62	0.5	IP40
SP5050	5.0 amps	147 x 86.5 x 62	0.6	IP40
SPTK5050	5.0 amps	147 x 86.5 x 62	0.8	IP40
SP5010	10.0 amps	185 x 172 x 135	2.0	IP54

* Note:- The max peak load current is for surface mounting installation.

Stock Ref

SP5001
 SP5025
 SP5050
 SPTK5050
 SP5010

Single Phase SPM (Auto-Transformer)



Features & Benefits

- Single Phase, 5 step auto-transformer speed controller
- Low motor noise - no magnetic hum
- ON/OFF Switch

Unit	Max Peak	Dimensions	Weight	Damper	
Stock Ref	Load Current	H x W x D (mm)	kg	Enclosure	Connection
SPM5020	2.0	230 x 168 x 118	2.2	IP54	Yes
SPM5035	3.5	230 x 168 x 118	4.6	IP54	Yes
SPM5060	6.0	230 x 166 x 118	5.0	IP50	Yes
SPM5075	7.5	284 x 240 x 132	6.2	IP54	Yes
SPM5090	9.0	316 x 270 x 168	10.5	IP54	No
SPM5140	14.0	316 x 270 x 168	16.5	IP54	No

Stock Ref

SPM5020
 SPM5035
 SPM5060
 SPM5075
 SPM5090
 SPM5140

Single Phase RTRE (Enhanced Auto-Transformer)



Features & Benefits

- Single Phase 5 step auto-transformer speed controller
- Separate starter not required when used with HOT SPOT protected fans
- Low motor noise - no magnetic hum
- Additional terminals to allow connection of remote switching device
- Allows operation via BMS interface
- Additional terminals to allow connection of remote anti-freezing thermostat

Unit	Max Peak	Dimensions	Weight	Damper		
Stock Ref	Load Current	H x W x D (mm)	kg	IP	Connection	VFC
RTRE20	2.0 amps	230 x 166 x 118	2.3	IP54	Yes	Yes
RTRE35	3.5 amps	230 x 166 x 118	3.6	IP54	Yes	Yes
RTRE60	6.0 amps	230 x 166 x 118	5.1	IP54	Yes	Yes
RTRE75	7.5 amps	284 x 240 x 132	6.1	IP54	Yes	Yes
RTRE90	9.0 amps	284 x 240 x 132	10.6	IP54	Yes	Yes

Stock Ref

RTRE20
RTRE35
RTRE60
RTRE75
RTRE90

Three Phase RDTK (Auto - Transformer)



Features & Benefits

- Three phase 5 step auto - transformer speed controller
- Separate starter not required when used with HOT SPOT protected fans
- Low motor noise - no magnetic hum
- Compact fire retardant surface mounting enclosure
- Additional terminals to allow connection of remote switching device
- Additional terminals to allow connection of remote anti-freezing thermostat

Unit	Max Peak	Dimensions	Weight	Damper	
Stock Ref	Load Current	H x W x D (mm)	kg	Enclosure	Connection
RDTK10	1.0 amps	284 x 240 x 132	4.7	IP54	Yes
RDTK20	2.0 amps	284 x 240 x 132	7.4	IP54	Yes
RDTK40	4.0 amps	316 x 270 x 168	12.9	IP21	No
RDTK70	7.0 amps	324 x 270 x 168	15.6	IP21	Yes
RD14	14.0 amps	295 x 400 x 170	30.0	IP21	No

Stock Ref

RDTK10
RDTK20
RDTK40
RDTK70
RD14

Starters & Overloads

Features & Benefits

- Suitable for all models
- Push button Start/Stop
- 240V contactor coil for single phase applications and three phase supplies where a neutral is present
- 415V contactor coil for three phase supplies where a neutral is not present or required
- Protection is given by an overload relay which is selected to match the load of the fan
- Enclosures are protected to IP55



Stock Ref	Starters	DOL Rating (Amps)	Star Delta Rating (Amps)	Dimensions HXWXD	Weight Kg
444744	DOL Starter 1 Phase 240V 12A	12	-	174x104x134	3.0
444745	DOL Starter 1 Phase 240V 25A	25	-	174x104x134	1.5
444746	DOL Starter 1 Phase 240V 32A	32	-	184x184x149	2.5
444747	DOL Starter 3 Phase 415V 12A	12	-	174x104x134	3.0
444748	DOL Starter 3 Phase 415V 25A	25	-	174x104x134	3.5
444749	DOL Starter 3 Phase 415V 32A	32	-	184x184x149	2.5
444750	DOL Starter 3 Phase 415 V 50A	50	-	305x285x159	7.0
444842	Star Delta Starter 21A	n/a	21	184x284x149	3.5
444843	Star Delta Starter 30A	n/a	30	184x284x149	3.5

Stock Ref	Overloads	DOL Rating (Amps)	Star Delta Rating (Amps)
444696	OVERLOAD 0.16-0.25	0.16-0.25	-
444697	OVERLOAD 0.25-0.40	0.25-0.40	-
444698	OVERLOAD 0.40-0.63	0.40-0.63	-
444699	OVERLOAD 0.63-1.0	0.63-1.0	-
444700	OVERLOAD 1.0-1.6	1.0-1.6	-
444701	OVERLOAD 1.6-2.5	1.6-2.5	2.7-4.3
444702	OVERLOAD 2.5-4.0	2.5-4.0	4.3-6.9
444703	OVERLOAD 4.0-6.0	4.0-6.0	6.9-10
444704	OVERLOAD 5.5-8.0	5.5-8.0	9.5-13.8
444705	OVERLOAD 7-10	7-10	12-17
444706	OVERLOAD 10-13	10-13	17-22
444707	OVERLOAD 13-18	13-18	22-31
444708	OVERLOAD 18-25	18-25	31-43
444709	OVERLOAD 23-32A	23-32A	39-55

This range of Starters and Overloads is not cross compatible with previous versions.

Sonex Circular Sound Attenuators

Features & Benefits

- Low cost – exceptional performance, exstock availability
- Sheet steel casing and end plates 30 minute fire rating as standard
- Fitted spigot for direct connection to circular ductwork



Application Data

The effective and economic solution for sound attenuation in circular duct systems from 100 to 500mm diameter. With at least three models per size throughout the range the system designer is given complete flexibility of choice allowing a selection which is the best balance of attenuation, size and cost for any application. Sonex Attenuators are fitted with a patented duct seal which enables leak free 'plug-in' connection to rigid ductwork with consequent savings of installation costs. The excellent attenuation characteristics of the Sonex range are achieved without imposing undue system resistance. Pressure losses are little more than those which would occur over a comparable section of straight duct.

Construction

The attenuator consists of a perforated tubular liner manufactured from sheet steel. The liner is enclosed by a thick layer of mineral wool sound absorbing material. Casing and end plates are formed from galvanised sheet steel. Standard models have a 30 minute fire rating (60 minutes also available).

Dimensions, Weights & Insertion Loss

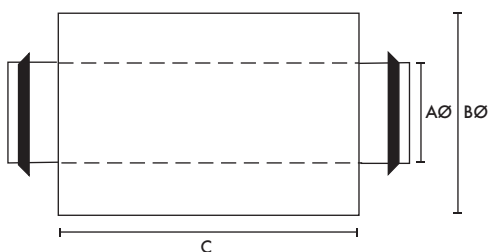

Stock Ref	Dimensions (mm)			Attenuation dB mid Frequency Hz								
	AØ	BØ	C	kg.	63	125	250	500	1K	2K	4K	8k
83010030	100	200	300	2.4	3	3	9	17	23	26	25	13
83010060	100	200	600	4.1	6	9	15	34	40	40	37	18
83010090	100	200	900	6.6	10	13	21	40	45	39	36	16
83012030	125	225	300	2.6	3	3	7	16	20	24	22	17
83012060	125	225	600	4.5	5	8	13	29	35	35	32	22
83012090	125	225	900	7.6	10	12	19	37	40	38	34	32
83015030	150	260	300	2.9	3	3	6	13	19	23	22	16
83015060	150	260	600	5.8	5	7	12	24	30	35	31	20
83015090	150	260	900	9	8	10	15	32	38	37	34	29
83016030	160	260	300	2.9	3	3	6	13	19	23	22	16
83016060	160	260	600	5.8	5	7	12	24	30	35	31	20
83016090	160	260	900	9	8	10	15	32	38	37	34	29
83020060	200	300	600	7	4	6	10	20	27	33	19	17
83020090	200	300	900	10	8	9	14	28	32	35	28	25
83020120	200	300	1200	14	10	12	17	36	41	43	28	26
83025060	250	355	600	8.6	4	5	10	19	25	29	18	17
83025090	250	355	900	12.2	6	7	12	23	30	30	22	19
83025120	250	355	1200	18	8	10	15	32	37	38	26	20
83031060	315	400	600	9.8	4	5	8	15	20	22	17	15
83031090	315	400	900	15	5	7	10	20	30	29	18	16
83031120	315	400	1200	21	7	9	13	22	32	33	19	18
83040090	400	606	900	21	3	5	9	19	26	20	13	11
83040120	400	606	1200	27	6	8	14	24	30	28	17	9
83050090	500	711	900	29	3	4	9	15	23	17	12	11
83050120	500	711	1200	38	5	7	13	18	26	23	15	9

Pyrocheck Intumescent Fire Dampers

Features & Benefits

- Suitable for air transfer in doors and partitions
- Complete seal achieved in approximately five minutes when tested in accordance with BS 476 pt 20 & 22
- UV Stabilised material UPVC
- Pyrocheck offer much lower resistance to airflow compared to traditional designs
- Independently tested to BS 476 pt. 22; fire integrity of 68 mins



Pyrocheck CVT Intumescent Fire Dampers are circular and have a minimum fire integrity of one hour (in accordance with BS476 Part 8 1972). The fire dampers have been independently tested at the Warrington Fire Research Centre.

Intumescent fire dampers require no mechanical or external device to operate as they rely solely on an internal reaction initiated by heat. They are, therefore, especially suitable for applications where regular inspection is unlikely or difficult or where mechanical devices would be susceptible to shock or corrosion damage.

Typical applications are air transfer in fire doors or partitions.

The active material is encased in a PVC sleeve giving maximum protection against moulds, fungi, insect attack or similar biological damage, and may reasonably be expected to last for the life of the building. Unaffected by UV light, capable of withstanding freeze/thaw cycling and able to support ambient temperatures within the range -10°C to +80°C.

In a fire situation Pyrocheck CVT Dampers will rapidly expand to completely block the duct or opening thus preventing the further passage of smoke and hot gasses.

An unusually high free area means that Pyrocheck CVT Dampers offer much lower resistance to air flow compared to traditional intumescent designs.

Dimensions

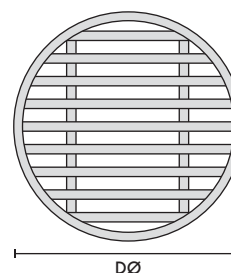

Stock Ref	DØ
CVT100	100
CVT130	125
CVT150	150
CVT200	198
CVT250	248
CVT300	298

Vent-Axia does not guarantee compliance with Building Regulations Part B, Fire Spread or other regulations that relate to fire planning. Suitability to comply with these regulations should be determined prior to installation and in conjunction with Building Control Officers. Compliance with the Regulations is specifically excluded from quotations and designs.

Models

Size	Stock Ref
4" Ø	CVT100
5" Ø	CVT130
6" Ø	CVT150
8" Ø	CVT200
10" Ø	CVT250
12" Ø	CVT300

Unitex Roof Cowl System

Features & Benefits

- Complete weather proofing with low pressure drop
- Size 160 to 250 supplied with bird guard
- Galvanised steel construction additionally protected by a dark brown epoxy powder coat finish (110mm grey PVC)
- Weather apron in stock aluminium
- Suitable for flat or pitched roofs up to 20° as standard
- Can be supplied in special colours to match building design (110mm grey PVC only)



The Unitex Roof Cowl System greatly simplifies the roof termination of mechanical ventilation systems. Consisting of an attractive epoxy finished cowl with a lead weather slate and a range of direct connection reducing fittings. It is suitable for connection to spiral duct, soil pipe and flexible duct from 125 to 250mm diameter.

Product Range

Cowl Assembly

WB160 For ducts from 125 to 160mm
WB200 For ducts from 200 to 250mm

Weather Apron for Flat Roofs

WA160
WA200

Weather Apron for Pitched Roofs (20° MAX)

WA160/20
WA200/20

Adaptor

370304 (125 to 150mm)
370309 (200 to 250mm)

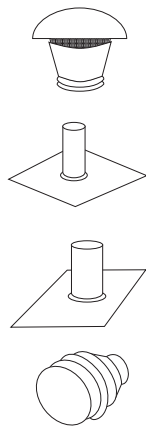

Installation with an Adaptor

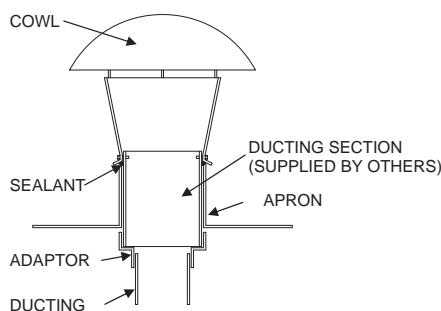

WB160 with 125mm connection using adaptor 370304
WB200 with 250mm connection using adaptor 370309

Models



110mm (4") Roof System

Description
PVC Roof Cowl
Weather Apron (pitch roofs)

Stock Ref
WRC100
WA100



125mm to 160mm Roof System

Description
Roof Cowl - Standard Colour BSO8B29
Roof Cowl - Non-standard Colour
Weather Apron (flat roofs)

Stock Ref
WB160
WB160C
WA160



200mm to 250mm Roof System

Description
Roof Cowl - Standard Colour BSO8B29
Roof Cowl - Non-standard Colour
Weather Apron (flat roofs)

Stock Ref
WB200
WB200C
WA200

Weather Apron for pitched roof

Description
Weather Apron 20° (max) pitch roof
Weather Apron 20° (max) pitch roof

Stock Ref
WA160/20
WA200/20

Adaptor

Description
OR16012 (125 to 150mm)
OR25020 (200 to 250mm)

Stock Ref
370304
370309

Unitex Wall Terminals

Features & Benefits

- External weather louvre, wall sleeve and duct connection spigot in one unit
- Satin anodised louvre gives full weather protection
- Epoxy powder coated finish, weather louvre available as optional extra
- 280mm or 80mm wall sleeve section
- Spigot connections from 100mm to 400mm



The Unitex SA Wall Terminal Module consists of a high grade satin anodised weather louvre fitted with bird guard (epoxy finish optional extra). This is located in a galvanised sheet metal 'box section' linked to a reinforced circular stub for direct connection to rigid or flexible ductwork.

Two lengths of 'box section' are available; 80mm and 280mm. An airstream operated back draught shutter can be fitted in the 280mm version. For applications where larger air volumes are involved the Unitex QSA range of wall terminals is available.

Note:

Volume Control Dampers, Speed Clamps & Backdraught Shutters available: see Accessories Section.

Models

Description	Stock Ref
80mm wall sleeve, std. format louvre	
100mm	SA100/80
125mm	SA125/80
150mm	SA150/80
200mm	SA200/80
250mm	SA250/80
315mm	SA315/80

80mm wall sleeve, large format louvre

125mm	QSA125/80
200mm	QSA200/80
250mm	QSA250/80
315mm	QSA315/80

280mm wall sleeve, std. format louvre

100mm	SA100/280
125mm	SA125/280
150mm	SA150/280
200mm	SA200/280
250mm	SA250/280
315mm	SA315/280

280mm wall sleeve, large format louvre

100mm	QSA100/280
125mm	QSA125/280
150mm	QSA150/280
200mm	QSA200/280
250mm	QSA250/280
315mm	QSA315/280
400mm	QSA400/280

Dimensions (mm)

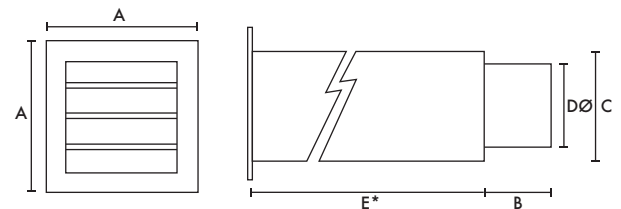

*Dimensions E select from 280 or 80mm

Model Ref	A	B	C	DØ
SA100	180	80	130	99
SA125	210	80	160	124
SA150	230	80	180	149
SA200	280	80	230	199
SA250	330	80	280	249
SA315	400	80	350	313
QSA100	230	80	180	98
QSA125	280	80	230	124
QSA150	330	80	280	149
QSA200	400	80	350	199
QSA250	500	80	450	249
QSA315	550	80	500	313
QSA400	550	80	500	400

Stock Reference Index

Stock Ref	Product	Page
120801	Genova Cooker Hood - Silver	60
120841	Milano Cooker Hood - Silver	60
120851	Roma Cooker Hood - Silver	60
140120	VA140/150KP (Pullcord)	50
140220	VA140/150KT (Timer)	50
140320	VA140/150KHP (Humidistat)	50
140420	VA140/150KHT (Humidistat/Timer)	50
140901	Window Fitting Kit White	168
140902	Wall Fitting Kit White	168
140903	Wall Fitting Kit Brown	168
152110	VA150P	51
153110	VA150A	51
165510	ST355-16-WL	204
165620	STGF355	204
165710	STX355	204
165810	STARX355	204
165910	STAR355	204
166510	ST400-16-WL	204
166620	STGF400	204
166710	STX400	204
167510	ST450-16-WL	204
167710	STX450	204
167810	STARX450	204
167910	STAR450	204
168510	ST500-16-WL	204
168710	STX500	204
181510	Multivent MV250	74
181520	Lo-Carbon Multivent MVDC	72
183010	Multivent MV250H	74
183020	Lo-Carbon Multivent MVDCH	72
188110	LuminAir L	40
188210	LuminAir T	40
188610	LuminAir H	40

Stock Ref	Product	Page
231710	S6SD/R	209
232710	S7SD/R	209
233710	S9SD/R	209
234710	S12SD/R	209
248710	Minivent SK	62
248810	Minivent SKT	62
249944	Horizontal 45° Bend 204x60 Uninsulated	158
251110	VA100LP	34
251210	VA100LT (Timer)	34
251310	VA100XP (Shutter)	34
251410	VA100XT (Timer/Shutter)	34
251510	VA100XHT (Shutter/Humidity/Timer)	34
251610	VA100LHP (Humidity)	34
251710	VA100XHP (Shutter/Humidity)	34
254100	Wall Kit Brown	168
254101	Window Fitting Kit	168
254102	Wall Kit White	168
256120	Centrif Duo P	54
256220	Centrif Duo T (Timer)	54
256320	Centrif Duo DP (Two Speed)	54
256420	Centrif Duo HTP (Humidity)	54
258110	VA100SVL12	34
258112	VA100SVLHP12	34
258310	VA100SVX12	34
258312	VA100SVXH12	34
258410	VA100SVXT12	34
258512	VA100SVXHT12	34
370127	Round to Rectangular Adaptor	162
370179	Acoustic Mat	165
370202	90° Bend 200Ø	166
370203	90° Bend 250Ø	166
370238	Equal Tee 200Ø	166
370239	Equal Tee 250Ø	166

Stock Ref	Product	Page
370295	90° Bend 150mmØ	163
370299	Circular Connector 150Ø	163
370302	Reducer R125/100	164
370303	Reducer R150/100	164
370304	Reducer R150/125	164
370307	Reducer R200/150	164
370309	Reducer R250/200	164
370310	Reducer R300/100	164
370312	Reducer R300/200	164
370328	RD104TC Louvre Grille with Spigot	169
370329	RD104BR Louvre Grille with Spigot	169
370330	RD104WH Louvre Grille with Spigot	169
370337	RD604BR Louvre Grille with Spigot	169
370338	RD604TC Louvre Grille with Spigot	169
370339	RD604WH Louvre Grille with Spigot	169
370346	TIM2 Overrun Timer	259
370356	VCON6	258
370377	HR100R	136
370394	HR300	94
370402	HR300 Filters	94
370421	HR200WK Extension Wall Sleeve	92
370422	HR300 Extension Wall Sleeve	94
370447	HR500IP	144
370450	HR500D	142
370451	HR500EP	144
370538	VT100 Tile Vent	165
371301	Collar for Exhaust &	165
372004	90° Bend 100mmØ	163
372005	45° Bend 100mmØ	163
372006	Circular Connector 100Ø	163
372007	Equal Tee Uninsulated MMM 100Ø	162
372261	Lo-Carbon HR25	90
372262	Lo-Carbon HR25H	90

Stock Ref	Product	Page
372264	Lo-Carbon HR25L	90
372265	Lo-Carbon HR25LH	90
400144	Flush metal wall box	251
400733	Round to Rectangular Adaptor	160
400735	Flat Channel Connector with Damper 110x54	160
400740	Round to Rectangular Adaptor 100mm 125Ø	161
400743	Louvred Grille with Flyscreen	161
400749	Equal Tee 100Ø	166
400750	Equal Tee 125Ø	166
400751	Equal Tee 150Ø	166
400752	90° Bend 100Ø	166
400753	90° Bend 125Ø	166
400754	90° Bend 150Ø	166
400755	Female Coupler 100Ø	166
400756	Female Coupler 125Ø	166
400757	Female Coupler 150Ø	166
400758	Balancing Damper 100Ø	166
400759	Balancing Damper 125Ø	166
400760	Balancing Damper 150Ø	166
400900	Spiral Ductwork - 3 m length 100Ø	166
400901	Spiral Ductwork - 3 m length 125Ø	166
400902	Spiral Ductwork - 3 m length 150Ø	166
403025	Flat Channel Duct 220x90 Uninsulated	158
403026	Flat Channel Connector	158
403027	Elbow bend 100mm 220x90	159
403028	Horizontal 90° bend 220x90 Uninsulated	158
403029	Vertical 90° Bend Uninsulated	159
403030	Channel Fixing Clip	158
403031	Round Adaptor 220x90x150mm	162
403255	Low Resistance Air Brick 1st Fix Duct Section	157
403431	Circular Fire Valve 100mm	167
403432	Circular Fire Valve 125mm	167
403698	Rectangular Balancing Damper 204x60	166

Stock Reference Index

Stock Ref	Product	Page
403699	Rectangular Balancing Damper 220x90	166
403832	Lo-Carbon Tempra 460mm LP	88
403833	Lo-Carbon Tempra 460mm SELV LP	88
403834	Lo-Carbon Tempra 460mm LT	88
403835	Lo-Carbon Tempra 460mm SELV LT	88
403836	Lo-Carbon Tempra 460mm LHTP	88
403837	Lo-Carbon Tempra 460mm SELV LHTP	88
403847	150mm Conversion Kit for Tempra	88
404106	Solo Plus Bezel Assembly	22
404274	Rectangular Fire Wrap & Cage 204x60mm	167
404276	Rectangular Fire Wrap & Cage 110x54mm	167
404535	Lo-Carbon Response dMEV	66
404876	Lo-Carbon Response TP	66
404877	Lo-Carbon Response Fan HTP	66
404878	Lo-Carbon Response Fan SELV TP	66
404879	Lo-Carbon Response Fan SELV HTP	66
405155	Lo-Carbon iQ	12
405156	Rectangular Balancing Damper 110x54	166
405215	Lo-Carbon Sentinel Kinetic Advance S	98
405216	Lo-Carbon Sentinel Kinetic Advance SX	98
406587	Semi-Rigid Ducting 75mmØx50m	152
406588	Semi-Rigid Ducting 90mmØx50m	152
406605	Lo-Carbon iQ Backdraught Shutter	12
406762	Lo-Carbon iQ Wall Mounting Plate	12
406870	Flat Channel Duct 204x60 Insulated	158
406871	Vertical 45° Bend 204x60 Insulated	159
406872	Vertical 90° Bend 204x60 Insulated	159
406873	Round 2m Ducting 100mmØ Insulated	162
406874	Round 2m Ducting 125mmØ Insulated	162
406875	Round 2m Ducting length Insulated 150mmØ	162
406876	Horizontal 45° Bend 204x60 Insulated	158
406877	45° Bend Insulated 100mmØ	163
406878	45° Bend Insulated 125mmØ	163

Stock Ref	Product	Page
406879	Horizontal 90° Bend 204x60 Insulated	158
406880	90° Bend Insulated 100mmØ	163
406881	90° Bend Insulated 125mmØ	163
406882	90° Bend Insulated 150mmØ	163
406883	Horizontal T-Piece 204x60 Insulated	159
406884	Equal Tee Insulated 100mmØ	162
406885	Equal Tee Insulated 125mmØ	162
406886	Equal Tee Insulated 150mmØ	162
407001	Lo-Carbon Sentinel Multivent Plus	76
407162	Lo-Carbon Sentinel Kinetic Horizontal 200ZPH	122
407206	Aluminium Pull-out System Hood	61
407287	Aircheck Kitchen Grille	165
407329	Universal Roof Vents 125mmØ - Red	154
407330	Universal Roof Vents 125mmØ - Brown	154
407331	Universal Roof Vents 125mmØ - Grey	154
407332	Universal Roof Vents 150mmØ - Red	154
407333	Universal Roof Vents 150mmØ - Brown	154
407334	Universal Roof Vents 150mmØ - Grey	154
407335	Universal Roof Vents 125mmØ - Slate Grey	154
407336	Universal Roof Vents 150mmØ - Slate Grey	154
407337	Universal Roof Vents 110mmØ - Black	154
407338	Universal Roof Vents 131mmØ - Black	154
407339	Universal Roof Vents 166mmØ - Black	154
407342	Horizontal 90° Bend 204x60 Insulated	158
407343	Flat Channel Duct 220x90 Uninsulated	158
407381	Aircheck Bathroom Grille	165
407382	Wind Baffle Kit White	171
407509	White Pull-out System Hood	61
407577	Wind Baffle Kit Brown	171
407582	Jet Dry White	218
407655	Round Fire Sleeve 100mmØ	167
407656	Round Fire Sleeve 125mmØ	167
407657	Round Fire Sleeve 150mmØ	167

Stock Ref	Product	Page
407658	Rectangular Fire Sleeve 110x54mm	167
407659	Rectangular Fire Sleeve 204x60mm	167
407660	Rectangular Fire Sleeve 220x90mm	167
407849	Lo-Carbon Sentinel Multivent Plus H	76
407927	Response Window Kit	66
407928	Response Ceiling Kit	66
408167	Lo-Carbon Sentinel Kinetic FH Right	108
408169	Lo-Carbon Sentinel Kinetic FH Left	108
408449	Kinetic High Flow Right	116
408451	Kinetic High Flow Left	116
408680	Response 150mm Conversion Kit	66
408828	Circular Fire Valve 200mm	167
408872	Arterial Single Spigot Adaptor 220x90 to 78Ø	150
408873	Arterial Double Connector Plate 220x90 to 78Ø	150
408874	Arterial Single Connector Plate 220x90 to 78Ø	150
408875	Arterial Blank Plate 220x90 to 78Ø	150
408885	Arterial Reducer 120 to 78Ø	150
409117	Jet Dry Plus Silver	218
409158	Sentinel Kinetic F Spare G3 filter 2 pack	108
409159	Solo Pro P	48
409160	Solo Pro T	48
409161	Solo Pro HTP	48
409162	Solo Pro TM	48
409163	Solo Pro SELV SVP	48
409164	Solo Pro SELV SVT	48
409165	Solo Pro SELV SVHTP	48
409195	Wifi Controller for Kinetic Advance	98
409802	Lo-Carbon Svara	10
409819	Back draught shutter for Svara	10
409820	Cover plate for Svara	10
410020	Surface mount box	250
410922	Spiral Ductwork - 3m length 200Ø	166
410923	Spiral Ductwork - 3m length 250Ø	166

Stock Ref	Product	Page
410924	Spiral Ductwork - 3m length 315Ø	166
410925	Equal Tee 315Ø	166
410927	Female Coupler 200Ø	166
410929	Female Coupler 315Ø	166
410930	Balancing Damper 200Ø	166
410931	Balancing Damper 250Ø	166
410932	Balancing Damper 315Ø	166
426035	Multivent Wireless Controller	72
426250	Convactor Heater	246
426715	Portable Fan Heater	247
427166	Rimini Cookerhood	60
427281	Eclipse 100XP	64
427282	Eclipse 100XT	64
427283	Eclipse 150X	64
427310	Eclipse 100X	64
427313	Eclipse 150XP	64
427360	90° Bend Uninsulated 125mmØ	163
427477	Solo Plus P (Pullcord)	46
427478	Solo Plus T (Timer)	46
427479	Solo Plus HT (Humidistat-timer)	46
427480	Solo Plus TM (Timer/PIR)	46
427481	Lo-Carbon Solo Plus P	22
427482	Lo-Carbon Solo Plus T	22
427483	Lo-Carbon Solo Plus HT	22
427484	Lo-Carbon Solo Plus TM	22
427485	Lo-Carbon Solo Plus SELV P	22
427486	Lo-Carbon Solo Plus SELV T	22
427487	Lo-Carbon Solo Plus SELV HT	22
427488	Lo-Carbon Solo Plus SELV TM	22
427583	12" Wall Fan	227
427584	Box Fan	227
427935	Easy Dry Range 1kW	220
427936	Easy Dry Range 2kW	220

Stock Reference Index

Stock Ref	Product	Page
428049	Ceiling Fan HL 90	225
428050	Ceiling Fan HL 120	225
428051	Ceiling Fan HL 140	225
428238	SAC5 Reversible Controller	225
428632	Reducer 150 -125Ø	163
428633	Circular Connector 125Ø	163
428636	Equal Tee 125Ø	162
431515	Easy Dry 1.5kW Metal	220
431613	Centrif Duo Plus P	54
431614	Centrif Duo Plus T	54
431615	Centrif Duo Plus DP	54
431616	Centrif Duo Plus HTP	54
432504	Shower Fan & Light Kit Basic	62
432505	Shower Fan & Light Kit Timer	62
433257	CO2 + Temp Room Sensor	79
434656	Quick Fix Termination	170
434715	Round 2m Ducting Uninsulated 125Ø	162
435004	HR100RS	136
435137	Intumescent Fire Wrap 110x54	167
435138	Intumescent Fire Wrap 204x60	167
435424	Turbodry White Manual	220
435427	Turbodry White Auto	220
435430	Turbodry Chrome Auto	220
435956	Current sensor 6m cable	256
435957	Current sensor 12m cable	256
435958	Temperature sensor 6m cable	256
435959	Temperature sensor 12m cable	256
435960	Ventwise 3 sensor inputs	256
436064	Lo-Carbon VA100 SELV XHTP	14
436297	Easy Dry 1.5kW ABS	220
436480	Eclipse Chrome Bezel 100mm	64
436483	Eclipse Chrome Bezel 150mm	64
436494	Warm Air curtain switch VARSU	245

Stock Ref	Product	Page
436519	Toilet/Bathroom BAS100B	62
436520	Toilet/Bathroom BAS100P	62
436521	Toilet/Bathroom BAS100T	62
436525	Kitchen BAS150B	62
436526	Kitchen BAS150P	62
436527	Kitchen BAS150T	62
436530	Toilet/Bathroom BAS100SLB	62
436532	Toilet/Bathroom BAS100SLT	62
436533	Kitchen/Utility BAS150SLB	62
436535	Kitchen/Utility BAS150SLT	64
436551	Horizontal T-Piece 204x60 Uninsulated	159
436580	PVC Flexible Ducting 100Ø	164
436584	PVC Flexible Ducting 125Ø	164
436588	PVC Flexible Ducting 150Ø	164
436592	PVC Flexible Ducting 200Ø	164
436599	Flat Channel Duct 204x60 Uninsulated	158
436602	Horizontal 90° Bend 110x54 Uninsulated	158
436603	Vertical 90° Bend 110x54 Uninsulated	159
436605	Flat Channel Connector 110x54	158
436606	Flat Channel Wall Plate 110x54	161
436607	Elbow Bend with 100mm Spigot 110x54	159
436608	Elbow Bend with Socket 110x54	160
436609	Grille Adaptor 110x54	161
436610	Horizontal Louvred Grille 110x54	160
436611	Horizontal Louvred Grille 204x60	160
436612	Horizontal Louvred Grille 204x60	160
436613	Horizontal Louvred Grille 204x60	160
436614	Horizontal T-Piece 110x54 Uninsulated	159
436617	Flat Channel Duct Uninsulated 204x60	158
436620	Horizontal 90° Bend 204x60 Uninsulated	158
436621	Vertical 90° Bend 204x60 Uninsulated	159
436623	Connector 204x60	158
436624	Elbow Bend with 100mm Spigot 204x60	159

Stock Ref	Product	Page
436625	Elbow Bend with 125mm Spigot 204x60	159
436626	Elbow Bend with 150mm Spigot 204x60	160
437320	Trickle/Boost Switch - SS	258
437598	Integral Humidistat	79
437601	Lo-Carbon Sentinel Multivent	76
437634	Lo-Carbon Multivent MVDC-MS	80
437666EC	Integra Plus EC	134
437827	Wireless Transmitter Controller	79
438195	Acoustic Lining Kit	72
438222	Sentinel Kinetic B Right	104
438342	Sentinel Kinetic V	104
438594	Soldier Louvred Grille 110x54	160
438604	Double Louvred Airbrick - White	161
438605	Double Louvred Airbrick - Brown	161
438606	Double Louvred Airbrick - Beige	161
438607	Double Louvred Airbrick - Terracotta	161
438608	Double Airbrick Adaptor	161
438673	VASH 6A Optimax Plus Storage Heater	243
438919	VACSH 12A Optimax Combination Heater	242
438920	VACSH 18A Optimax Combination Heater	242
438921	VACSH 24A Optimax Combination Heater	242
439034	VAPH075 Panel Heater	241
439035	VAPH 125 Panel Heater	241
439036	VAPH 150 Panel Heater	241
439037	VAPH 200 Panel Heater	241
439038	VAPH 075T Panel Heater	241
439039	VAPH 125T Panel Heater	241
439040	VAPH 150T Panel Heater	241
439041	VAPH 200T Panel Heater	241
439181	Lo-Carbon Quadra HTP	26
439251	Lo-Carbon Quadra TP	26
439253	Lo-Carbon Quadra TM	26
439256	Flush mounting Kit	26

Stock Ref	Product	Page
439352	Wireless Transmitter Controller Receiver Kit	79
439359	VASH 12A Optimax Plus Storage Heater	243
439360	VASH 18A Optimax Plus Storage Heater	243
439361	VASH 24A Optimax Plus Storage Heater	243
439463	Polished Stainless Hand Dryer	218
439464	Satin Stainless Hand Dryer	218
439927	Quadra & Centrif filter	26
439974	Silhouette 100SVB	36
439975	Silhouette 100SVT	36
439976	Silhouette 100SVH	36
441421	Lo-Carbon Minivent Shower Fan - Basic	24
441422	Lo-Carbon Minivent Shower Fan - Timer	24
441423	Lo-Carbon Vent-A-Light Fan & Light - Standard	25
441424	Lo-Carbon Vent-A-Light Fan & Light - Timer	25
441511	Lo-Carbon Silhouette 100SVB	16
441512	Lo-Carbon Silhouette 100SVT	16
441513	Lo-Carbon Silhouette 100SVH	16
441614	Lo-Carbon VA100 SELV LP	14
441615	Lo-Carbon VA100 SELV LT	14
441616	Lo-Carbon VA100 SELV LHTP	14
441624	Lo-Carbon Silhouette 100B	16
441625	Lo-Carbon Silhouette 100T	16
441626	Lo-Carbon Silhouette 100HT	16
441628	Lo-Carbon Silhouette 150B	30
441629	Lo-Carbon Silhouette 150T	30
441630	Lo-Carbon Silhouette 150HT	30
441654	Round to Rectangle Adaptor 100m 204x60	161
441655	Vertical 45° Bend 110x54 Uninsulated	159
441657	45° Bend Uninsulated 125mmØ	163
441774	Kinetic B/BH/C Spare G3 filter 2 pack	104
441780	Vent-Wise controller	103
441782	Lo-Carbon Centra	18
441865	Wireless enable kit	103

Stock Reference Index

Stock Ref	Product	Page
442030	Isolator Relay Controller	257
442273	Drop down section	160
442356	Kinetic V Spare G3 filter 2 pack	104
442551	Centrif Duo & Quadra Decoration Frame	169
442865	Lo-Carbon Quadra SVTP	26
442866	Lo-Carbon Quadra SVHTP	26
442867	Lo-Carbon Quadra SVTM	26
442947	Window Fitting Kit Centra/Silhouette 100	168
442954	Lo-Carbon Centra T	18
442955	Lo-Carbon Centra HT	18
443028	Lo-Carbon Kinetic Plus B Right	112
443045	Lo-Carbon Centra HTP	18
443159	Lo-Carbon VA100 LP (Pullcord)	14
443160	Lo-Carbon VA100 XP (Shutter/Pullcord)	14
443161	Lo-Carbon VA100 LT (Timer)	14
443162	Lo-Carbon VA100 XT (Shutter/Timer)	14
443163	Lo-Carbon VA100 LHTP (Humidity/Pullcord)	14
443164	Lo-Carbon VA100 XHTP (Shutter/Humidity/ Pullcord)	14
443175	Lo-Carbon Centra SELV T	18
443176	Lo-Carbon Centra SELV HT	18
443177	Lo-Carbon Centra SELV HTP	18
443234	Window Fitting Kit VA100 (110Ø)	168
443273	Acoustic Insulated Ducting 100mmØ 1m	164
443274	Acoustic Insulated Ducting 125mmØ 1.5m	164
443283	Wired Remote Controller	103
443298	Lo-Carbon Multivent MVDC-MSH	80
443310	Lo-Carbon Tempra T	88
443311	Lo-Carbon Tempra HTP	88
443312	Lo-Carbon Tempra P	88
443319	Sentinel Kinetic BH Right	104
443351	Kinetic Plus Spare G3 filter 2 pack	112
443793	Acoustic Insulated Ducting 150mmØ 1m	164
443800	Ceiling Mounting Kit 100mm	18

Stock Ref	Product	Page
444075	Lo-Carbon Pozidry	82
444076	Lo-Carbon Pozidry Compact	84
444199	Kinetic V Spare F5 pollen filter	100
444200	Kinetic B/BH Spare F5 pollen filter	100
444201	Kinetic Plus Spare F5 pollen filter	100
444368	Lo-Carbon Tempra SELV P	88
444369	Lo-Carbon Tempra SELV T	88
444370	Lo-Carbon Tempra SELV HTP	88
444696	Overload 0.16-0.25	320
444697	Overload 0.25-0.40	320
444698	Overload 0.40-0.63	320
444699	Overload 0.63-1.0	320
444700	Overload 1.0-1.6	320
444701	Overload 1.6-2.5	320
444702	Overload 2.5-4.0	320
444703	Overload 4.0-6.0	320
444704	Overload 5.5-8.0	320
444705	Overload 7-10	320
444706	Overload 10 - 13	320
444707	Overload 13- 18	320
444708	Overload 18-25	320
444709	Overload 23-32A	320
444744	DOL Starter 1 Phase 240V 12A	320
444745	DOL Starter 1 Phase 240V 25A	320
444746	DOL Starter 1 Phase 240V 32A	320
444747	DOL Starter 3 Phase 415V 12A	320
444748	DOL Starter 3 Phase 415V 25A	320
444749	DOL Starter 3 Phase 415V 32A	320
444750	DOL Starter 3 Phase 415V 50A	320
444766	Lo-Carbon Pozidry with integral heater	82
444767	Lo-Carbon Pozidry Compact with integral heater	84
444842	Star Delta Starter 21A	320
444843	Star Delta Starter 30A	320

Stock Ref	Product	Page
444956	Lo-Carbon eTempest	218
444959	Tempest Filter Assembly Pack	218
444960	Tempest Filter Replacement	218
445161	Silhouette 125B	39
445162	Silhouette 125T	39
445163	Silhouette 125H	39
445196	Vertical 45° Bend 204x60 Uninsulated	159
445529	Telescopic Wall Tube for Tempra	88
445655	Lo-Carbon Sentinel Multivent H	76
445832	Weathercowl (ERV1000)	271
445851	Filter G4 (ERV1000)	271
446174	Underfloor Heating Thermostatic Controller	234
446175	Underfloor Heat Mat 100 1m2	232
446176	Underfloor Heat Mat 100 1.5m2	232
446177	Underfloor Heat Mat 100 2m2	232
446178	Underfloor Heat Mat 100 2.5m2	232
446179	Underfloor Heat Mat 100 3m2	232
446180	Underfloor Heat Mat 100/HS 3.5m2	232
446181	Underfloor Heat Mat 100/HS 4m2	232
446182	Underfloor Heat Mat 100/HS 5m2	232
446183	Underfloor Heat Mat 100/HS 6m2	232
446184	Underfloor Heat Mat 100/HS 7m2	232
446185	Underfloor Heat Mat 100/HS 8m2	232
446186	Underfloor Heat Mat 100/HS 10m2	232
446187	Underfloor Heat Mat 100/HS 12m2	232
446188	Underfloor Heat Mat 150 1m2	232
446189	Underfloor Heat Mat 150 1.5m2	232
446190	Underfloor Heat Mat 150 2m2	232
446191	Underfloor Heat Mat 150 2.5m2	232
446192	Underfloor Heat Mat 150 3m2	232
446193	Underfloor Heat Mat 150/HS 3.5m2	232
446194	Underfloor Heat Mat 150/HS 4m2	232
446195	Underfloor Heat Mat 150/HS 5m2	232

Stock Ref	Product	Page
446196	Underfloor Heat Mat 150/HS 6m2	232
446197	Underfloor Heat Mat 150/HS 7m2	232
446198	Underfloor Heat Mat 150/HS 8m2	232
446199	Underfloor Heat Mat 150/HS 10m2	232
446200	Underfloor Heat Mat 150/HS 12m2	232
446201	Underfloor Heat Cable 300W	230
446202	Underfloor Heat Cable 400W	230
446203	Underfloor Heat Cable 500W	230
446204	Underfloor Heat Cable 600W	230
446205	Underfloor Heat Cable 700W	230
446206	Underfloor Heat Cable 840W	230
446207	Underfloor Heat Cable 1500W	230
446208	Underfloor Heat Cable 12500W	230
446209	Underfloor Heat Cable 1370W	230
446210	Underfloor Heat Cable 1700W	230
446211	Underfloor Heat Cable 2150W	230
446212	Underfloor Heat Cable 2600W	230
446213	Underfloor Heat Cable 3300W	230
446214	Splicing Kit for Underfloor Heating Cables	234
446269	Lo-Carbon Quadra SVTP Datalogger	26
446270	Lo-Carbon Quadra SVHTP Datalogger	26
446409	Ventwise 6 sensor inputs	256
446483	Lo-Carbon Silhouette 125B	28
446484	Lo-Carbon Silhouette 125T	28
446485	Lo-Carbon Silhouette 125HT	28
446523	Kinetic Plus 180mm/200mm Spigot Kit	112
446591	Weathercowl (ERV1500)	271
446658	Silent Fan VASF100B	38
446659	Silent Fan VASF100T	38
446756	Lo-Carbon Sentinel Kinetic CWH L	118
446757	Lo-Carbon Sentinel Kinetic CSH L	118
446758	Lo-Carbon Sentinel Kinetic CWH R	118
446759	Lo-Carbon Sentinel Kinetic CSH R	118

Stock Reference Index

Stock Ref	Product	Page
446877	Portable Insect Killer	221
446878	Insect Killer 50	221
446879	Insect Killer 80	221
446880	Insect Killer 150	221
447127	Lo-Carbon Centra TP	18
447128	Lo-Carbon Centra SELV TP	18
447251	Filter G4 (ERV1500)	271
447267	Underfloor Heat Insulation Boards 6mm	234
447268	Underfloor Heat Insulation Boards 10mm	234
447269	Underfloor Heat Insulation Boards 12mm	234
447270	Underfloor Heat Insulation Boards 20mm	234
447271	Underfloor Heat Insulation Boards 30mm	234
447272	Underfloor Heat Insulation Boards 40mm	234
447273	Underfloor Heat Insulation Boards 50mm	234
447274	Underfloor Heat Insulation Boards 60mm	234
447275	Underfloor Heat Insulation Boards 70mm	234
447276	Underfloor Heat Insulation Boards Tape	234
447277	Underfloor Heat Insulation Boards 10mm Screws	234
447278	Underfloor Heat Insulation Boards 20mm Screws	234
447279	Underfloor Heat Insulation Boards 30mm Screws	234
447280	Underfloor Heat Insulation Boards 40mm Screws	234
447281	Underfloor Heat Insulation Boards 50mm Screws	234
447282	Underfloor Heat Insulation Boards 60mm Screws	234
447283	Underfloor Heat Insulation Boards Washers	234
472318	Internal fit wall kit - White	156
472319	Internal fit wall kit - Brown	156
447340	Opto-Coupler	112
447600	Radiant Heater VARO 1800	239
447602	Radiant Heater VARI 2000	239
447603	Radiant Heater VARI 4000	239
447604	Radiant Heater VARI 6000	239
447854	VATRS100C Towel Rail	236
447855	VATRF150C Towel Rail	236

Stock Ref	Product	Page
447856	VATRF250W Towel Rail	236
447857	VATRF250C Towel Rail	236
447858	VATRF400C Towel Rail	236
447859	VATRC250C Towel Rail	236
447860	VATRC400C Towel Rail	236
447861	Atacama LS Towel Rail	236
447862	Atacama OS Towel Rail	236
447863	Atacama SS Towel Rail	236
447864	VATRCW Controller	236
447865	VATRCC Controller	236
447866	VATRDFK150 Replacement Element	236
447867	VATRDFK250 Replacement Element	236
447868	VATRDFK400 Replacement Element	236
448356	LED Indicator	258
448469	Opal Aluminium Radiators 500W	240
448470	Opal Aluminium Radiators 750W	240
448471	Opal Aluminium Radiators 1000W	240
448472	Opal Aluminium Radiators 1250W	240
448473	Opal Aluminium Radiators 1500W	240
448778	Lo-Carbon Sentinel Kinetic Horizontal 200ZMH	122
448919	Portable Air Conditioner	226
448929	Momentary Push Switch	258
449011	100mm High Rise Kit for Tempra	88
449059	Lo-Carbon Kinetic Plus E	128
449060	Normal Boost Switch with Light Indicator	258
449071	PIV Twin Spigot Kit	82
449223	Low Resistance Air Brick White	157
449224	Low Resistance Air Brick Brown	157
449225	Low Resistance Air Brick Stone	157
449226	Low Resistance Air Brick Grey	157
449227	Low Resistance Air Brick Terracotta	157
449265	Solo Plus Filter Pack	22
449361	Elbow bend 125mm 220x90	159

Stock Ref	Product	Page
449362	Elbow bend 150mm 220x90	160
449363	Horizontal 45° Bend 220x90 Uninsulated	158
449364	Vertical 45° bend 220x90 Uninsulated	159
449365	Horizontal T 220x90 Uninsulated	159
449366	3M Flexible Rectangular duct	161
449524	Kinetic 200Z/ZH/ZMH Spare G3 filter 2 Pack	122
449536	Lo-Carbon Sentinel Kinetic Horizontal 300ZH	122
449540	Lo-Carbon Sentinel Kinetic Horizontal 200ZH	122
449575	Kinetic 300ZH Spare G3 filter 2 Pack	122
452044	LuminAir Bezels Chrome	42
452045	LuminAir Bezels Gold	42
452076	Duct Y-Piece 250/250mm	164
452078	Duct Y-Piece 200/250mm	164
452079	Duct Y-Piece 250/300mm	164
452081	Duct Y-Piece 100/100mm	164
452082	Duct Y-Piece 100/150mm	164
452083	Duct Y-Piece 150/150mm	164
452084	Duct Y-Piece 150/200mm	164
452085	Duct Y-Piece 200/200mm	164
452094	Wind Baffle 100mm White	171
452095	Wind Baffle 100mm Brown	171
452096	Wind Baffle 150mm White	171
452097	Wind Baffle 150mm Brown	171
452550	Replacement Grease Filter 355	204
452551	Replacement Grease Filter 450	204
452725	Heavy Duty wall fan Grille size 6	266
452726	Heavy Duty wall fan Grille size 7	266
452727	Heavy Duty wall fan Grille size 9	266
452728	Heavy Duty wall fan Grille size 12	266
452814	Replacement Air Filters 355	204
452815	Replacement Air Filters 450	204
453182	Freshvent 100 Thermo	58
453188	Filter for Freshvent 100	58

Stock Ref	Product	Page
453197	Filter for Freshvent 100 Thermo	58
453200	Freshvent 100	58
453206	Storm Sheild for Freshvent	58
453208	Freshvent 100 dB	58
453253	Freshvent 100 Thermo dB	58
453275	Freshvent Extension Bushing	58
453395	LuminAir Vent Light SELV Duct Air Inlet	40
453410	LuminAir Shower Ventilation Kit L - White	42
453413	LuminAir Shower Ventilation Kit T - White	42
453416	LuminAir Shower Ventilation Kit H - White	42
453419	LuminAir Turbo SKL	44
453422	LuminAir Turbo SKT	44
453546	Installation Packs for Pozidry Compact	84
453547	Installation Packs for Pozidry Compact	84
453548	Installation Packs for Pozidry Compact	84
453915	Hand Dryer + Dryline	219
454055	Silhouette 100B	36
454056	Silhouette 100T	36
454057	Silhouette 100H	36
454058	Silhouette 100TM	36
454059	Silhouette 150X	52
454060	Silhouette 150XT	52
454061	Silhouette 150XH	52
455035	Short Round to Rectangular Adaptor 100mm 110x54	162
455190	Condensation Trap 150mm	170
455191	Condensation Trap 125mm	170
455211	Duct Y Piece 2x 125mm into 1x 125mm	164
455212	Duct Y Piece 2x 125mm into 1x 150mm	164
455213	Normal Boost Switch	258
455219	Aircheck Ceiling Adaptor - (CA125)	165
455226	125mm Wall Kits	39
455262	Window Wind Cowl	171
455873	Controllers Wired T-series	182

Stock Reference Index

Stock Ref	Product	Page
455874	Controllers Wireless T-series	182
456343	Warm Air Curtains 3kW	245
456344	Warm Air Curtains 4.5kW	245
456345	Warm Air Curtains 6kW	245
456864	Integra	132
457485	Jupiter - NJUP315	224
457486	Jupiter - NJUP315CTS	224
457487	Jupiter - NJUP400	224
457488	Jupiter - NJUP400CTS	224
457490	Suspension Pack	224
457845	100mm Wind Cowl White	170
457986	Remote Delay Timer	257
458153	Fan Speed Adjuster	256
458915	VA140/150VS	50
459049	Lo-Carbon VA100 SELV XP	14
459050	Lo-Carbon VA100 SELV XT	14
459112	Plinth Heaters VAPL2-S	244
459113	Plinth Heaters VAPL2-W	244
459114	Plinth Heaters VAPL2-B	244
459115	Plinth Heaters VAPL2TC-S	244
459116	Plinth Heaters VAPL2TC-W	244
459117	Plinth Heaters VAPL2TC-B	244
459123	Lo-Carbon VA150P	29
459124	Lo-Carbon VA150T	29
459125	Lo-Carbon VA150HP	29
459623	Vent-Axia Visionex PIR 225 x 25	255
459624	Vent-Axia Visionex SELV 12 PIR	255
459746	2-Way Switch and Neons	259
460086	T-Series Wall Liners size 6	261
460096	T-Series Wall Liners size 12	261
460585	T-Series Darkroom Cowl Assembly size 6	262
460586	T-Series Darkroom Cowl Assembly size 7	262
460587	T-Series Darkroom Cowl Assembly size 9	262

Stock Ref	Product	Page
460588	T-Series Darkroom Cowl Assembly size 12	262
468728	Terracotta Soldier Louvred Airbrick	160
468729	Beige Soldier Louvred Airbrick	160
468730	Brown Soldier Louvred	160
472012	Traditional T-Series 6" Core	192
472013	Traditional T-Series 7" Core	192
472014	Traditional T-Series 9" Core	192
472015	Traditional T-Series 12" Core	192
472016	Traditional T-Series 6" Wall Kit	194
472017	Traditional T-Series 7" Wall Kit	194
472018	Traditional T-Series 9" Wall Kit	194
472019	Traditional T-Series 12" Wall Kit	194
472020	Traditional T-Series 6" Window Kit	192
472021	Traditional T-Series 7" Window Kit	192
472022	Traditional T-Series 9" Window Kit	192
472023	Traditional T-Series 12" Window Kit	192
472024	Traditional T-Series 6" Panel Kit	198
472025	Traditional T-Series 7" Panel Kit	198
472026	Traditional T-Series 9" Panel Kit	198
472027	Traditional T-Series 12" Panel Kit	198
472028	Traditional T-Series 6" Roof Kit	196
472029	Traditional T-Series 7" Roof Kit	196
472030	Traditional T-Series 9" Roof Kit	196
472031	Traditional T-Series 12" Roof Kit	196
472032	Traditional T-Series 6" Darkroom Kit	200
472033	Traditional T-Series 7" Darkroom Kit	200
472034	Traditional T-Series 9" Darkroom Kit	200
472035	Traditional T-Series 12" Darkroom Kit	200
472036	Traditional T-Series 6" In-line Kit	202
472037	Traditional T-Series 9" In-line Kit	202
472038	Traditional T-Series 12" In-line Kit	202
472039	Lo-Carbon T-Series 9" Wired Core	182
472040	Lo-Carbon T-Series 12" Wired Core	182

Stock Ref	Product	Page
472041	Lo-Carbon T-Series 9" Wireless Core	182
472042	Lo-Carbon T-Series 12" Wireless Core	182
472043	Lo-Carbon T-Series 9" Wired Wall Kit	184
472044	Lo-Carbon T-Series 12" Wired Wall Kit	184
472045	Lo-Carbon T-Series 9" Wireless Wall Kit	184
472046	Lo-Carbon T-Series 12" Wireless Wall Kit	184
472047	Lo-Carbon T-Series 9" Wired Window Kit	182
472048	Lo-Carbon T-Series 12" Wired Window Kit	182
472049	Lo-Carbon T-Series 9" Wireless Window Kit	182
472050	Lo-Carbon T-Series 12" Wireless Window Kit	182
472051	Lo-Carbon T-Series 9" Wired Panel Kit	188
472052	Lo-Carbon T-Series 12" Wired Panel Kit	188
472053	Lo-Carbon T-Series 9" Wireless Panel Kit	188
472054	Lo-Carbon T-Series 12" Wireless Panel Kit	188
472055	Lo-Carbon T-Series 9" Wired Roof Kit	186
472056	Lo-Carbon T-Series 12" Wired Roof Kit	186
472057	Lo-Carbon T-Series 9" Wireless Roof Kit	186
472058	Lo-Carbon T-Series 12" Wireless Roof Kit	186
472442	Traditional Standard Panel 6" Fan	214
472443	Traditional Standard Panel 7" Fan	214
472444	Traditional Standard Panel 9" Fan	214
472445	Traditional Standard Panel 12" Fan	214
472226	Traditional Standard Window/Roof 6" Core	208
472227	Traditional Standard Window/Roof 7" Core	208
472228	Traditional Standard Window/Roof 9" Core	208
472229	Traditional Standard Window/Roof 12" Core	208
472230	Traditional Standard Window 6" Kit	208
472231	Traditional Standard Window 7" Kit	208
472232	Traditional Standard Window 9" Kit	208
472233	Traditional Standard Window 12" Kit	208
472234	Traditional Standard Roof 6" Kit	210
472235	Traditional Standard Roof 7" Kit	210
472236	Traditional Standard Roof 9" Kit	210

Stock Ref	Product	Page
472237	Traditional Standard Roof 12" Kit	210
472248	Uniflex+ 90° Valve Collector (2xØ90 - Ø125)	152
472249	Uniflex+ 90° Valve Collector (1xØ90 - Ø125)	152
472250	Uniflex+ Distribution Box (12xØ90 - Ø125)	152
472251	Uniflex+ Distribution Box (8xØ90 - Ø125)	152
472252	Uniflex+ Ø90 Ductknife	152
472253	Uniflex+ 90° Bend (Ø90mm)	152
472254	Uniflex+ Ø90mm Coupler	152
472255	Uniflex+ 90° Valve Collector (2xØ75 - Ø125)	152
472256	Uniflex+ Distribution Box (12xØ75 - Ø125)	152
472257	Uniflex+ Distribution Box (8xØ75 - Ø125)	152
472258	Uniflex+ Ø75 Ductknife	152
472259	Uniflex+ 90° Bend (Ø75mm)	152
472260	Uniflex+ Ø75mm Coupler	152
472261	Uniflex+ Straight Valve Collector (2xØ75 - Ø125)	152
472262	Uniflex+ Straight Valve Collector (2xØ90 - Ø125)	152
473848	Lo-Carbon Revive 7	20
473849	Lo-Carbon Revive SELV 7	20
473850	Lo-Carbon Revive 5	20
473851	Lo-Carbon Revive SELV 5	20
473852	Lo-Carbon Revive	20
473853	Lo-Carbon Revive SELV	20
474041	Revive & Response Decoration Frame	21
474077	Semi-Rigid Ducting 75mmØx25m	152
474078	Semi-Rigid Ducting 90mmØx25m	152
560136	Roof Plate Assemblies size 6	267
560137	Roof Plate Assemblies size 7	267
560139	Roof Plate Assemblies size 9	267
560142	Roof Plate Assemblies size 12	267
560161	Roof Termination 6RF	265
560162	Roof Termination 7RF	265
560163	Roof Termination 9RF	265
560164	Roof Termination 12RF	265

Stock Reference Index

Stock Ref	Product	Page
560236	Mounting Boxes 6/7	261
560239	Mounting Boxes 9/12	261
560501	Direct Mount Spigot size 6	262
560502	Direct Mount Spigot size 7	262
560503	Direct Mount Spigot size 9, WW/RF	262
560504	Direct Mount Spigot size 9, WL/PL	262
560505	Direct Mount Spigot size 12	262
560601	Plenum Box 125/150mm	263
560602	Plenum Box 150/175mm	263
560603	Plenum Box 200/225mm	263
560604	Plenum Box 250/300mm	263
560605	Plenum Box 315/400mm	263
560637	Single Spigots 6 175mm(B)	261
560639	Single Spigots 6/7 225mm(B)	261
560640	Single Spigots 7 250mm(A)	261
560642	Single Spigots 9 300mm(A)	261
560734	2-3-4 Spigot Plate	262
560735	5 Spigot Plate	262
560846	Eggcrate Grille - White, 125mm	264
560847	Eggcrate Grille - White, 200mm	264
560848	Eggcrate Grille - White, 250mm	264
560849	Eggcrate Grille - White, 300mm	264
560850	Eggcrate Grille - White, 450mm	264
560856	Terminal Connector	168
560900	Non-Vision Grille + Flanges - Brown 150mm	266
560901	Non-Vision Grille + Flanges - Brown 300mm	266
560910	External Louvres - Brown, 225mm	266
560911	External Louvres - Brown, 300mm	266
560912	External Louvres - Brown, 400mm	266
560913	External Louvres - Brown, 450mm	266
560936	Cone Connectors size 6	262
561011	Standard Range Adaptor Kits - Size 6	267
561012	Standard Range Adaptor Kits - Size 7	267

Stock Ref	Product	Page
561013	Standard Range Adaptor Kits - Size 9	267
561014	Standard Range Adaptor Kits - Size 12	267
561136	Fixing Plates 6	260
561137	Fixing Plates 7	260
561139	Fixing Plates 9	260
561142	Fixing Plates 12	260
561301	Eggcrate Grille - Satin, 300mm	264
561302	Eggcrate Grille - Satin, 450mm	264
561303	Eggcrate Grille - Satin, 200mm	264
561305	Eggcrate Grille - Satin, 250mm	264
561311	Non-Vision Grille - Satin, 300mm	265
561312	Non-Vision Grille - Satin, 450mm	265
561321	Non-Vision Grille - Satin, 300mm	265
561322	Non-Vision Grille - Satin, 450mm	265
561341	Opposed Blade Dampers - 200mm	264
561342	Opposed Blade Dampers - 250mm	264
561343	Opposed Blade Dampers - 300mm	264
561344	Opposed Blade Dampers - 450mm	264
561350	External Louvres Satin Finish	266
561351	External Louvre Satin, 225mm	266
561352	External Louvres Satin, 300mm	266
561355	External Louvres Satin, 450mm	266
561370	Single Deflection Grille 200mm	263
561371	Single Deflection Grille 250mm	263
561372	Single Deflection Grille 300mm	263
561373	Single Deflection Grille 450mm	263
561380	Double Deflection Grille 200mm	263
561381	Double Deflection Grille 250mm	263
561382	Double Deflection Grille 300mm	263
561383	Double Deflection Grille 450mm	263
561390	Non-Vision Grille + Flange - Satin 0/150mm	266
561391	Non-Vision Grille + Flange - Satin 0/300mm	266
561400	Air Replacement Grille Set - Brown	170

Stock Ref	Product	Page
561401	Air Replacement Grille Set - Ivory	170
561403	Vent Cowl Grey	170
561411	Louvre Grille - Size 6, Brown	266
561412	Louvre Grille - Size 7, Brown	266
561413	Louvre Grille - Size 9, Brown	266
561414	Louvre Grille - Size 12, Brown	266
561421	Louvre Grille - Size 6 White	266
561422	Louvre Grille - Size 7 White	266
561423	Louvre Grille - Size 9 White	266
561424	Louvre Grille - Size 12 White	266
561654	Insulated Flexible Ducting - 100mm	164
561655	Insulated Flexible Ducting - 125mm	164
561656	Insulated Flexible Ducting - 150mm	164
561704	Worm Drive Clips - 110mm	267
561707	Worm Drive Clips - 180mm	267
561710	Worm Drive Clips - 270mm	267
561715	Worm Drive Clips - 380mm	267
561720	Worm Drive Clips - 525mm	267
561726	Worm Drive Clips - 600mm	267
561804	Joining Piece - 100mm Ø	166
561805	Joining Piece - 125mm Ø	166
561806	Joining Piece - 150mm Ø	166
561808	Joining Piece - 200mm Ø	166
561809	Joining Piece - 225mm Ø	166
561810	Joining Piece - 250mm Ø	166
561812	Joining Piece - 300mm Ø	166
561813	Joining Piece - 315mm Ø	166
561816	Joining Piece - 400mm Ø	166
561901	Fire Damper size 6/7	265
561902	Fire Damper size 9/12	265
563000	Joining Bolt Set	261
563106	Standard Range Protective Grille - size 6	262
563107	Standard Range Protective Grille - size 7	262

Stock Ref	Product	Page
563109	Standard Range Protective Grille - size 9	262
563112	Standard Range Protective Grille - size 12	262
563406	Standard Range Protective Grille - size 6	262
563407	Standard Range Protective Grille - size 7	262
563409	Standard Range Protective Grille - size 9	262
563412	Standard Range Protective Grille - size 12	262
563500	Air Grille White	168
563501	Vent-Axia HumidiSwitch	253
563502	Vent-Axia ThermoSwitch	254
563506	Air Quality Sensor	251
563511	Air Grille Brown	168
563513	Termination Set	168
563515	7 Day TimeSwitch	254
563516	Condensation Trap	170
563518	3 Pole Isolator	255
563519	TimeSpan Controller	250
563521	Quick Fix Wall Grille - White	170
563522	Quick Fix Airflow Shutter - White	169
563531	Ecotronic SELV 12	253
563532	Ecotronic Humidity Sensor	253
563533	3 Speed Controller	259
563535	Quick Fix Termination	170
563538	150VA Transformer	257
563541	Quick Fix Wall Grille - Brown	170
563542	Quick Fix Airflow Shutter - Brown	169
563548	Guardian Personnel Detector	254
563550	Ambient Response Humidity Sensor	252
563551	Ambient Response SELV 12	252
563552	Lo-Carbon Ambient Response Humidity Sensor	252
566142	Single Spigot size 9	261
566146	Single Spigot size 12	261
566607	PVC Flexible Ducting 175Ø	164
566609	PVC Flexible Ducting 225Ø	164

Stock Reference Index

Stock Ref	Product	Page
566612	PVC Flexible Ducting 300Ø	164
566616	PVC Flexible Ducting 400Ø	164
568104	T-Series Fixing Rod Set size 6/7/9	260
568106	T-Series Fixing Rod Set size 12	260
5108248	Round 2m Ducting 150mmØ Uninsulated	162
5108250	Round 2m Ducting 100mmØ Uninsulated	162
5108454	Normal Boost Purge	258
5109662	Flexible Connection 204 x 60mm	161
10314103	3A Transformer Controller	256
10314105	5A Transformer Controller	256
10314107	7A Transformer Controller	256
10314200	ITC Man/Auto Changeover Controller	313
10314210	ITC-DS12/24hr Auto Changeover Controller	313
10314220	RVC®ELV Remote Visual Indicator	313
10502325	Impeller Discharge Side Guide 250/315	281
10502375	Impeller Discharge Side Guide 355	281
10502450	Impeller Discharge Side Guide 400	281
10502525	Impeller Discharge Side Guide 450/500	281
10502630	Impeller Discharge Side Guide 560/630	281
10502800	Impeller Discharge Side Guide 710/800	281
10532200	Pre Filter Cassette	313
10532250	Pre Filter Cassette	313
10532315	Pre Filter Cassette	313
10538290	HR500DP	146
10540200	Fast Clamp	313
10540250	Fast Clamp	313
10540315	Fast Clamp	313
10542200	Backdraught Shutter	313
10542250	Backdraught Shutter	313
10542315	Backdraught Shutter	313
10543100	Round Supply Diffuser - 100mm	164
10543125	Round Supply Diffuser - 125mm	164
10543150	Round Supply Diffuser - 150mm	164

Stock Ref	Product	Page
10544100	Round Exhaust Diffuser - 100mm	164
10544125	Round Exhaust Diffuser - 125mm	164
10544150	Round Exhaust Diffuser - 150mm	164
10544200	Round Exhaust Diffuser - 200mm	164
10546230	4-Way Diffuser - 200/225mm	264
10546300	4-Way Diffuser - 250/300mm	264
10546350	4-Way Diffuser - 300/315/350mm	264
10546400	4-Way Diffuser - 400mm	264
10546450	4-Way Diffuser - 450mm	264
10547150	4-Way Diffuser Neck Adptr - 150mm	264
10547200	4-Way Diffuser Neck Adptr - 200mm	264
10547250	4-Way Diffuser Neck Adptr - 250mm	264
10547300	4-Way Diffuser Neck Adptr 300/315	264
10547400	4-Way Diffuser Neck Adptr 400	264
10548400	4-Way Diffuser Neck Adptr 400	264
10555150	100/125/150 Roof Termination	265
10555200	200mm Roof Termination	265
10555250	250mm Roof Termination	265
10555315	315mm Roof Termination	265
10577315	Heat Exchange Spigot Adptr	313
10578315	Heat Exchange Spigot Adptr	313
11461685	Window Fitting Kit	168
14101010	HR500	140
14101070	HR500X	140
14120010	HR200V	138
14120020	HR200WK	92
17104010	ACM100	174
17104020	ACM100T	174
17105010	ACM125	174
17105020	ACM125T	174
17106010	ACM150	174
17106020	ACM150T	174
17108010	ACM200	174

Stock Ref	Product	Page
17108020	ACM200T	174
17110010	ACM250	176
17112010	ACM315	176
20101402	Professional E	219
20101440	Prepdry-Stainless Steel	219
83010030	In-Line Attenuators 100mm Ø 300mm	321
83010060	In-Line Attenuators 100mm Ø 600mm	321
83010090	In-Line Attenuators 100mm Ø 900mm	321
83012030	In-Line Attenuators 125mm Ø 300mm	321
83012060	In-Line Attenuators 125mm Ø 600mm	321
83012090	In-Line Attenuators 125mm Ø 900mm	321
83015030	In-Line Attenuators 150mm Ø 300mm	321
83015060	In-Line Attenuators 150mm Ø 600mm	321
83015090	In-Line Attenuators 150mm Ø 900mm	321
83016030	In-Line Attenuators 160mm Ø 300mm	321
83016060	In-Line Attenuators 160mm Ø 600mm	321
83016090	In-Line Attenuators 160mm Ø 900mm	321
83020060	In-Line Attenuators 200mm Ø 600mm	321
83020090	In-Line Attenuators 200mm Ø 900mm	321
83020120	In-Line Attenuators 200mm Ø 1200mm	321
83025060	In-Line Attenuators 250mm Ø 600mm	321
83025090	In-Line Attenuators 250mm Ø 900mm	321
83025120	In-Line Attenuators 250mm Ø 1200mm	321
83031060	In-Line Attenuators 315mm Ø 600mm	321
83031090	In-Line Attenuators 315mm Ø 900mm	321
83031120	In-Line Attenuators 315mm Ø 1200mm	321
83040090	In-Line Attenuators 400mm Ø 900mm	321
83040120	In-Line Attenuators 400mm Ø 1200mm	321
83050090	In-Line Attenuators 500mm Ø 900mm	321
83050120	In-Line Attenuators 500mm Ø 1200mm	321
105021000	Impeller Discharge Side Guide 1000	281
10531100T1	Electric Heaters	313
10531125T1	Electric Heaters	313

Stock Ref	Product	Page
10531150T1	Electric Heaters	313
10531200T1	Electric Heaters	313
10531250T1	Electric Heaters	313
10531315T1	Electric Heaters	313
10556200A	5 Spare Pre Filters	313
10556250A	5 Spare Pre Filters	313
10556315A	5 Spare Pre Filters	313
20101600SX	Powerdry SX	219
20101800SX	Ultradry SX	219
20101840SX	Ultradry SX Stainless Steel	219
258310BDO25	VA100SVXP12	34
438222L	Sentinel Kinetic B Left	104
443028L	Lo-Carbon Kinetic Plus B Left	112
443319L	Sentinel Kinetic BH Left	104
63PF665	Spare Panel Filter 500Ø	301
68MP033G	Anti Vibration Mounts (set of 4)	289
ACOB1A	Manual & Auto Changeover controller	309
ACP10012	Powerflow - 100mm	178
ACP12512	Powerflow - 125mm	178
ACP15012	Powerflow - 150mm	178
ACP16012	Powerflow - 160mm	178
ACP20012	Powerflow - 200mm	178
ACP25012	Powerflow - 250mm	178
ACP31512	Powerflow - 315mm	178
ACZ2501D	Attenuator 250mm Ø 1D Long No Pod	288
ACZ2502D	Attenuator 250mm Ø 2D Long No Pod	288
ACZ3151D	Attenuator 315mm Ø 1D Long No Pod	288
ACZ3151DP	Attenuator 315mm Ø 1D Long with Pod	288
ACZ3152D	Attenuator 315mm Ø 2D Long No Pod	288
ACZ3152DP	Attenuator 315mm Ø 2D Long with Pod	288
ACZ3551D	Attenuator 355mm Ø 1D Long No Pod	288
ACZ3551DP	Attenuator 355mm Ø 1D Long with Pod	288
ACZ3552D	Attenuator 355mm Ø 2D Long No Pod	288

Stock Reference Index

Stock Ref	Product	Page
ACZ3552DP	Attenuator 355mm Ø 2D Long with Pod	288
ACZ4001D	Attenuator 400mm Ø 1D Long No Pod	288
ACZ4001DP	Attenuator 400mm Ø 1D Long with Pod	288
ACZ4002D	Attenuator 400mm Ø 2D Long No Pod	288
ACZ4002DP	Attenuator 400mm Ø 2D Long with Pod	288
ACZ4501D	Attenuator 450mm Ø 1D Long No Pod	288
ACZ4501DP	Attenuator 450mm Ø 1D Long with Pod	288
ACZ4502D	Attenuator 450mm Ø 2D Long No Pod	288
ACZ4502DP	Attenuator 450mm Ø 2D Long with Pod	288
ACZ5001D	Attenuator 500mm Ø 1D Long No Pod	288
ACZ5001DP	Attenuator 500mm Ø 1D Long with Pod	288
ACZ5002D	Attenuator 500mm Ø 2D Long No Pod	288
ACZ5002DP	Attenuator 500mm Ø 2D Long with Pod	288
ACZ5601D	Attenuator 560mm Ø 1D Long No Pod	288
ACZ5601DP	Attenuator 560mm Ø 1D Long with Pod	288
ACZ5602D	Attenuator 560mm Ø 2D Long No Pod	288
ACZ5602DP	Attenuator 560mm Ø 2D Long with Pod	288
ACZ6301D	Attenuator 630mm Ø 1D Long No Pod	288
ACZ6301DP	Attenuator 630mm Ø 1D Long with Pod	288
ACZ6302D	Attenuator 630mm Ø 2D Long No Pod	288
ACZ6302DP	Attenuator 630mm Ø 2D Long with Pod	288
ACZ7101D	Attenuator 710mm Ø 1D Long No Pod	288
ACZ7101DP	Attenuator 710mm Ø 1D Long with Pod	288
ACZ7102D	Attenuator 710mm Ø 2D Long No Pod	288
ACZ7102DP	Attenuator 710mm Ø 2D Long with Pod	288
ACZ8001D	Attenuator 800mm Ø 1D Long No Pod	288
ACZ8001DP	Attenuator 800mm Ø 1D Long with Pod	288
ACZ8002D	Attenuator 800mm Ø 2D Long No Pod	288
ACZ8002DP	Attenuator 800mm Ø 2D Long with Pod	288
APZ250	Ancillary Pack 250mm Ø	289
APZ315	Ancillary Pack 315mm Ø	289
APZ355	Ancillary Pack 355mm Ø	289
APZ400	Ancillary Pack 400mm Ø	289

Stock Ref	Product	Page
APZ450	Ancillary Pack 450mm Ø	289
APZ500	Ancillary Pack 500mm Ø	289
APZ560	Ancillary Pack 560mm Ø	289
APZ630	Ancillary Pack 630mm Ø	289
APZ710	Ancillary Pack 710mm Ø	289
APZ800	Ancillary Pack 800mm Ø	289
BDS100	Back Draught Shutters 100mm Ø	309
BDS125	Back Draught Shutters 125mm Ø	309
BDS150	Back Draught Shutters 150mm Ø	309
BDS200	Back Draught Shutters 200mm Ø	309
BDS250	Back Draught Shutters 250mm Ø	309
BDS315	Back Draught Shutters 315mm Ø	309
CFZ250	Matching Flanges 250mm Ø	289
CFZ315	Matching Flanges 315mm Ø	289
CFZ355	Matching Flanges 355mm Ø	289
CFZ400	Matching Flanges 400mm Ø	289
CFZ450	Matching Flanges 450mm Ø	289
CFZ500	Matching Flanges 500mm Ø	289
CFZ560	Matching Flanges 560mm Ø	289
CFZ630	Matching Flanges 630mm Ø	289
CFZ710	Matching Flanges 710mm Ø	289
CFZ800	Matching Flanges 800mm Ø	289
CVT100	Intumescent Fire Damper 4" Ø	322
CVT130	Intumescent Fire Damper 5" Ø	322
CVT150	Intumescent Fire Damper 6" Ø	322
CVT200	Intumescent Fire Damper 8" Ø	322
CVT250	Intumescent Fire Damper 10" Ø	322
CVT300	Intumescent Fire Damper 12" Ø	322
ERV1000HIS	ERV-HiBox Standard 1000	271
ERV1500HIS	ERV-HiBox Standard 1500	271
ESC100036	S/Cased Fan 1000mm Ø, 3 ph. 6 Pole	288
ESC25012	S/Cased Fan 250mm Ø, 1 ph. 2 Pole	288
ESC25014	S/Cased Fan 250mm Ø, 1 ph. 4 Pole	288

Stock Ref	Product	Page
ESC25032	S/Cased Fan 250mm Ø, 3 ph. 2 Pole	288
ESC31512	S/Cased Fan 315mm Ø, 1 ph. 2 Pole	288
ESC31514	S/Cased Fan 315mm Ø, 1 ph. 4 Pole	288
ESC31532	S/Cased Fan 315mm Ø, 3 ph. 2 Pole	288
ESC35514	S/Cased Fan 355mm Ø, 1 ph. 4 Pole	288
ESC35532	S/Cased Fan 355mm Ø, 3 ph. 2 Pole	288
ESC35534	S/Cased Fan 355mm Ø, 3 ph. 4 Pole	288
ESC40014	S/Cased Fan 400mm Ø, 1 ph. 4 Pole	288
ESC40034	S/Cased Fan 400mm Ø, 3 ph. 4 Pole	288
ESC45014	S/Cased Fan 450mm Ø, 1 ph. 4 Pole	288
ESC45034	S/Cased Fan 450mm Ø, 3 ph. 4 Pole	288
ESC50014	S/Cased Fan 500mm Ø, 1 ph. 4 Pole	288
ESC50034	S/Cased Fan 500mm Ø, 3 ph. 4 Pole	288
ESC56014	S/Cased Fan 560mm Ø, 1 ph. 4 Pole	288
ESC56016	S/Cased Fan 560mm Ø, 1 ph. 6 Pole	288
ESC56034	S/Cased Fan 560mm Ø, 3 ph. 4 Pole	288
ESC63014	S/Cased Fan 630mm Ø, 1 ph. 4 Pole	288
ESC63016	S/Cased Fan 630mm Ø, 1 ph. 6 Pole	288
ESC63034	S/Cased Fan 630mm Ø, 3 ph. 4 Pole	288
ESC63036	S/Cased Fan 630mm Ø, 3 ph. 6 Pole	288
ESC71016	S/Cased Fan 710mm Ø, 1 ph. 6 Pole	288
ESC71034	S/Cased Fan 710mm Ø, 3 ph. 4 Pole	288
ESC71036	S/Cased Fan 710mm Ø, 3 ph. 6 Pole	288
ESC80034	S/Cased Fan 800mm Ø, 3 ph. 4 Pole	288
ESC80036	S/Cased Fan 800mm Ø, 3 ph. 6 Pole	288
ESP100036	S/Cased Fan 1000mm Ø, 3 ph. 6 Pole	281
ESP100038	S/Cased Fan 1000mm Ø, 3 ph. 8 Pole	281
ESP25012	Plate Fan 250mm Ø, 1 ph. 2 Pole	281
ESP25014	Plate Fan 250mm Ø, 1 ph. 4 Pole	281
ESP25032	Plate Fan 250mm Ø, 3 ph. 2 Pole	281
ESP31512	Plate Fan 315mm Ø, 1 ph. 2 Pole	281
ESP31514	Plate Fan 315mm Ø, 1 ph. 4 Pole	281
ESP31532	Plate Fan 315mm Ø, 3 ph. 2 Pole	281

Stock Ref	Product	Page
ESP31534	Plate Fan 315mm Ø, 3 ph. 4 Pole	281
ESP35514	Plate Fan 355mm Ø, 1 Ph. 4 Pole	281
ESP35516	Plate Fan 355mm Ø, 1 Ph. 6 Pole	281
ESP35534	Plate Fan 355mm Ø, 3 Ph. 4 Pole	281
ESP35536	Plate Fan 355mm Ø, 3 Ph. 6 Pole	281
ESP40014	Plate Fan 400mm Ø, 1 Ph. 4 Pole	281
ESP40016	Plate Fan 400mm Ø, 1 Ph. 6 Pole	281
ESP40034	Plate Fan 400mm Ø, 3 Ph. 4 Pole	281
ESP40036	Plate Fan 400mm Ø, 3 Ph. 6 Pole	281
ESP45014	Plate Fan 450mm Ø, 1 Ph. 4 Pole	281
ESP45016	Plate Fan 450mm Ø, 1 Ph. 6 Pole	281
ESP45034	Plate Fan 450mm Ø, 3 Ph. 4 Pole	281
ESP45036	Plate Fan 450mm Ø, 3 Ph. 6 Pole	281
ESP50014	Plate Fan 500mm Ø, 1 Ph. 4 Pole	281
ESP50034	Plate Fan 500mm Ø, 3 Ph. 4 Pole	281
ESP50036	Plate Fan 500mm Ø, 3 Ph. 6 Pole	281
ESP56014	Plate Fan 560mm Ø, 1 Ph. 4 Pole	281
ESP56016	Plate Fan 560mm Ø, 1 Ph. 6 Pole	281
ESP56034	Plate Fan 560mm Ø, 2 Ph. 4 Pole	281
ESP56036	Plate Fan 560mm Ø, 3 Ph. 6 Pole	281
ESP63014	Plate Fan 630mm Ø, 1 Ph. 4 Pole	281
ESP63016	Plate Fan 630mm Ø, 1 Ph. 6 Pole	281
ESP63034	Plate Fan 630mm Ø, 3 Ph. 4 Pole	281
ESP63036	Plate Fan 630mm Ø, 3 Ph. 6 Pole	281
ESP63038	Plate Fan 630mm Ø, 3 Ph. 8 Pole	281
ESP71016	Plate Fan 710mm Ø, 1 Ph. 6 Pole	281
ESP71034	Plate Fan 710mm Ø, 3 Ph. 4 Pole	281
ESP71036	Plate Fan 710mm Ø, 3 Ph. 6 Pole	281
ESP71038	Plate Fan 710mm Ø, 3 Ph. 8 Pole	281
ESP80034	Plate Fan 800mm Ø, 3 Ph. 4 Pole	281
ESP80036	Plate Fan 800mm Ø, 3 Ph. 6 Pole	281
ESP80038	Plate Fan 800mm Ø, 3 Ph. 8 Pole	281
ESR100036	Plate Fan 1000mm Ø, 3 Ph. 6 Pole	296

Stock Reference Index

Stock Ref	Product	Page
ESR100038	Plate Fan 1000mm Ø, 3 Ph. 8 Pole	296
ESR25012	Roof Fan 250mm Ø, 1Ph. 2 Pole	296
ESR25032	Roof Fan 250mm Ø, 3 Ph. 2 Pole	296
ESR31512	Roof Fan 315mm Ø, 1 Ph. 2 Pole	296
ESR31514	Roof Fan 315mm Ø, 1 Ph. 4 Pole	296
ESR31532	Roof Fan 315mm Ø, 3 Ph. 2 Pole	296
ESR31534	Roof Fan 315mm Ø, 3 Ph. 4 Pole	296
ESR35514	Roof Fan 355mm Ø, 1 Ph. 4 Pole	296
ESR35516	Roof Fan 355mm Ø, 1 Ph. 6 Pole	296
ESR35534	Roof Fan 355mm Ø, 3 Ph. 4 Pole	296
ESR35536	Roof Fan 355mm Ø, 3 Ph. 6 Pole	296
ESR40014	Roof Fan 400mm Ø, 1 Ph. 4 Pole	296
ESR40016	Roof Fan 400mm Ø, 1 Ph. 6 Pole	296
ESR40034	Roof Fan 400mm Ø, 3 Ph. 4 Pole	296
ESR40036	Roof Fan 400mm Ø, 3 Ph. 6 Pole	296
ESR45014	Roof Fan 450mm Ø, 1 Ph. 6 Pole	296
ESR45034	Roof Fan 450mm Ø, 3 Ph. 4 Pole	296
ESR45036	Roof Fan 450mm Ø, 3 Ph. 6 Pole	296
ESR50014	Roof Fan 500mm Ø, 1 Ph. 4 Pole	296
ESR50034	Roof Fan 500mm Ø, 3 Ph. 4 Pole	296
ESR50036	Roof Fan 500mm Ø, 3 Ph. 6 Pole	296
ESR56014	Roof Fan 560mm Ø, 1 Ph. 4 Pole	296
ESR56034	Roof Fan 560mm Ø, 3 Ph. 4 Pole	296
ESR56036	Roof Fan 560mm Ø, 3 Ph. 6 Pole	296
ESR63014	Roof Fan 630mm Ø, 1 Ph. 4 Pole	296
ESR63016	Roof Fan 630mm Ø, 1 Ph. 6 Pole	296
ESR63034	Roof Fan 630mm Ø, 3 Ph. 4 Pole	296
ESR63036	Roof Fan 630mm Ø, 3 Ph. 6 Pole	296
ESR63038	Roof Fan 630mm Ø, 3 Ph. 8 Pole	296
ESR71016	Roof Fan 710mm Ø, 1Ph. 6 Pole	296
ESR71034	Roof Fan 710mm Ø, 3Ph. 4 Pole	296
ESR71036	Roof Fan 710mm Ø, 3 Ph. 6 Pole	296
ESR71038	Roof Fan 710mm Ø, 3 Ph. 8 Pole	296

Stock Ref	Product	Page
ESR80034	Roof Fan 800mm Ø, 3 Ph. 4 Pole	296
ESR80036	Roof Fan 800mm Ø, 3 Ph. 6 Pole	296
ESR80038	Roof Fan 800mm Ø, 3 Ph. 8 Pole	296
ESR25014	Roof Fan 250mm Ø, 1Ph. 4 Pole	296
FILTERQPFB250	Spare bag filters	301
FILTERQPFB315	Spare bag filters	301
FILTERQPFB400	Spare bag filters	301
FILTERS100	Spare panel filters	301
FILTERS125160	Spare panel filters	301
FILTERS200	Spare panel filters	301
FILTERS250	Spare panel filters	301
FILTERS315	Spare panel filters	301
FILTERS400	Spare panel filters	301
FLX200	Flexible Connection	309
FLX250	Flexible Connection	309
FLX315	Flexible Connection	309
LS1000	Louvre Shutter - Size 1000	281
LS250	Louvre Shutter - Size 250	281
LS315	Louvre Shutter - Size 315	281
LS350	Louvre Shutter - Size 350	281
LS400	Louvre Shutter - Size 400	281
LS450	Louvre Shutter - Size 450	281
LS500	Louvre Shutter - Size 500	281
LS560	Louvre Shutter - Size 560	281
LS630	Louvre Shutter - Size 630	281
LS710	Louvre Shutter - Size 710	281
LS800	Louvre Shutter - Size 800	281
MFZ250	Mounting Feet 250mm Ø	289
MFZ315	Mounting Feet 315mm Ø	289
MFZ355	Mounting Feet 355mm Ø	289
MFZ400	Mounting Feet 400mm Ø	289
MFZ450	Mounting Feet 450mm Ø	289
MFZ500	Mounting Feet 500mm Ø	289

Stock Ref	Product	Page
MFZ560	Mounting Feet 560mm Ø	289
MFZ630	Mounting Feet 630mm Ø	289
MFZ710	Mounting Feet 710mm Ø	289
MFZ800	Mounting Feet 800mm Ø	289
QP100B	Quiet Pack 100mm Ø	301
QP125B	Quiet Pack 125mm Ø	301
QP150B	Quiet Pack 150mm Ø	301
QP160B	Quiet Pack 160mm Ø	301
QP200A	Quiet Pack 200mm Ø	301
QP250B	Quiet Pack 250mm Ø	301
QP315B	Quiet Pack 315mm Ø	301
QP400B	Quiet Pack 400mm Ø	301
QP500B	Quiet Pack 500mm Ø	301
QPF100A	Panel Filters	317
QPF125A	Panel Filters	317
QPF150A	Panel Filters	317
QPF200A	Panel Filters	317
QPF250A	Panel Filters	317
QPF315A	Panel Filters	317
QPFB100A	Bag Filters	317
QPFB125A	Bag Filters	317
QPFB150A	Bag Filters	317
QPFB200A	Bag Filters	317
QPFB250A	Bag Filters	317
QPFB315A	Bag Filters	317
QPTW100	Quiet Pack Twin Fan 100mm Ø	305
QPTW125	Quiet Pack Twin Fan 125mm Ø	305
QPTW150	Quiet Pack Twin Fan 150mm Ø	305
QPTW160	Quiet Pack Twin Fan 160mm Ø	305
QPTW200	Quiet Pack Twin Fan 200mm Ø	305
QPTW250	Quiet Pack Twin Fan 250mm Ø	305
QPTW315	Quiet Pack Twin Fan 315mm Ø	305
QPTW400	Quiet Pack Twin Fan 400mm Ø	305

Stock Ref	Product	Page
QPTW500	Quiet Pack Twin Fan 500mm Ø	305
QSA100/280	100mm Ø 280mm wall sleeve	324
QSA125/280	125mm Ø 280mm wall sleeve	324
QSA125/80	125mm Ø 80mm wall sleeve	324
QSA150/280	150mm Ø 280mm wall sleeve	324
QSA200/280	200mm Ø 280mm wall sleeve	324
QSA200/80	200mm Ø 80mm wall sleeve	324
QSA250/280	250mm Ø 280mm wall sleeve	324
QSA250/80	250mm Ø 80mm wall sleeve	324
QSA315/280	315mm Ø 280mm wall sleeve	324
QSA315/80	315mm Ø 80mm wall sleeve	324
QSA400/280	400mm Ø 280mm wall sleeve	324
RD14	Auto Transformer 14Amp, 3 Phase	319
RDTK10	Auto Transformer 1Amp, 3 Phase	319
RDTK20	Auto Transformer 2Amp, 3 Phase	319
RDTK4	Auto Transformer 4Amp, 3 Phase	319
RDTK7	Auto Transformer 7Amp, 3 Phase	319
RTRE20	Speed Controller 2Amp, 1 Phase	319
RTRE35	Speed Controller 3.5Amp, 1 Phase	319
RTRE60	Speed Controller 6Amp, 1 Phase	319
RTRE75	Speed Controller 7.5Amp, 1 Phase	319
RTRE9	Speed Controller 9Amp, 1 Phase	319
SA100/280	Unitex Wall Terminals 100mmØ 280mm Sleeve	324
SA100/80	Unitex Wall Terminals 100mmØ 80mm Sleeve	324
SA125/280	Unitex Wall Terminals 125mmØ 280mm Sleeve	324
SA125/80	Unitex Wall Terminals 125mmØ 80mm Sleeve	324
SA150/280	Unitex Wall Terminals 150mmØ 280mm Sleeve	324
SA150/80	Unitex Wall Terminals 150mmØ 80mm Sleeve	324
SA200/280	Unitex Wall Terminals 200mmØ 280mm Sleeve	324
SA200/80	Unitex Wall Terminals 200mmØ 80mm Sleeve	324
SA250/280	Unitex Wall Terminals 250mmØ 280mm Sleeve	324
SA250/80	Unitex Wall Terminals 250mmØ 80mm Sleeve	324
SA315/280	Unitex Wall Terminals 315mmØ 280mm Sleeve	324

Stock Reference Index

Stock Ref	Product	Page
SA315/80	Unitex Wall Terminals 315mmØ 80mm Sleeve	324
SDX100A	EuroSeries (SDX) 100mm	317
SDX125A	EuroSeries (SDX) 125mm	317
SDX150A	EuroSeries (SDX) 150mm	317
SDX200A	EuroSeries (SDX) 200mm	317
SDX200H	EuroSeries (SDX) 200mm - High Performance	317
SDX250A	EuroSeries (SDX) 250mm	317
SDX250H	EuroSeries (SDX) 250mm - High Performance	317
SDX315A	EuroSeries (SDX) 315mm	317
SLP100	Slimpack In-line centrifugal Fan	309
SLP125	Slimpack In-line centrifugal Fan	309
SLP150	Slimpack In-line centrifugal Fan	309
SLP200	Slimpack In-line centrifugal Fan	309
SLP250	Slimpack In-line centrifugal Fan	309
SLP315	Slimpack In-line centrifugal Fan	309
SLPF100	Panel Filters	309
SLPF125	Panel Filters	309
SLPF150	Panel Filters	309
SLPF200	Panel Filters	309
SLPF250	Panel Filters	309
SLPT200	Slimpack Twin Duct In-line Fan 200mm	313
SLPT250	Slimpack Twin Duct In-line Fan 250mm	313
SLPT315	Slimpack Twin Duct In-line Fan 315mm	313
SLS100/1	In-line Attenuators 900mm - 100mm Ø	309
SLS125/1	In-line Attenuators 900mm - 125mm Ø	309
SLS150/1	In-line Attenuators 900mm - 150mm Ø	309
SLS200/1	In-line Attenuators 900mm - 200mm Ø	309
SLS250/1	In-line Attenuators 900mm - 250mm Ø	309
SLS315/1	In-line Attenuators 900mm - 315mm Ø	309
SLSI100/1	In-line Attenuators 300mm - 100mm Ø	309
SLSI125/1	In-line Attenuators 300mm - 125mm Ø	309
SLSI150/1	In-line Attenuators 300mm - 150mm Ø	309
SLSI200/1	In-line Attenuators 300mm - 200mm Ø	309

Stock Ref	Product	Page
SLSI250/1	In-line Attenuators 300mm - 250mm Ø	309
SLSI315/1	In-line Attenuators 300mm - 315mm Ø	309
SP5001	Speed Controller 1Amp, 1 Phase	318
SP5010	Speed Controller 10Amp, 1 Phase	318
SP5025	Speed Controller 3Amp, 1 Phase	318
SP5050	Speed Controller 5Amp, 1 Phase	318
SPM5020	Auto Transformer 2Amp, 1 Phase	318
SPM5035	Auto Transformer 3.5Amp, 1 Phase	318
SPM5060	Auto Transformer 6Amp, 1 Phase	318
SPM5075	Auto Transformer 7.5Amp, 1 Phase	318
SPM5090	Auto Transformer 9Amp, 1 Phase	318
SPM5140	Auto Transformer 14Amp, 1 Phase	318
SPTK5050	Speed Controller 5Amp, 1 Phase	318
VA54119	Reducer 150 to 125 100Ø	163
W10303102M	Speed controller 2.5 Amp	204
W10554150	Window/Wall/Ceiling Termination Sets 150mm	265
W10554200	Window/Wall/Ceiling Termination Sets 200mm	265
W10554250	Window/Wall/Ceiling Termination Sets 250mm	265
W10554315	Window/Wall/Ceiling Termination Sets 315mm	265
W14301010	HR500 Controller	259
W161110A	Traditional T-Series 6" Window Fan	192
W161210A	Traditional T-Series 6" Roof Fan	196
W161240	Traditional T-Series 6" Darkroom Fan	200
W161510A	Traditional T-Series 6" Wall Fan	204
W161610A	Traditional T-Series 6" Panel Fan	198
W161710	Traditional T-Series 6" In-Line Fan	202
W162110A	Traditional T-Series 7" Window Fan	192
W162210	Traditional T-Series 7" Roof Fan	196
W162240A	Traditional T-Series 7" Darkroom Fan	200
W162510A	Traditional T-Series 7" Wall Fan	204
W162610A	Traditional T-Series 7" Panel Fan	198
W163110A	Traditional T-Series 9" Window Fan	192
W163210A	Traditional T-Series 9" Roof Fan	196

Stock Ref	Product	Page
W163240	Traditional T-Series 9" Darkroom Fan	200
W163510A	Traditional T-Series 9" Wall Fan	204
W163610A	Traditional T-Series 9" Panel Fan	198
W163710	Traditional T-Series 9" In-Line Fan	202
W164110A	Traditional T-Series 12" Window Fan	192
W164210A	Traditional T-Series 12" Roof Fan	196
W164240A	Traditional T-Series 12" Darkroom Fan	200
W164510A	Traditional T-Series 12" Wall Fan	204
W164610A	Traditional T-Series 12" Panel Fan	198
W164710	Traditional T-Series 12" In-Line Fan	202
W300310	1.5A Electronic Controller	251
W361119	T-Series Controller Surface mounting 220 - 240V	250
W362320	T-Series Ecotronic Controllers Surface mounting	250
W560151	Window/Wall/Ceiling Termination Sets 175mm	265
W560152	Window/Wall/Ceiling Termination Sets 225mm	265
W560153	Window/Wall/Ceiling Termination Sets 300mm	265
W560154	Window/Wall/Ceiling Termination Sets 400mm	265
W561031	T-Series Adaptor Kits 6"	260
W561032	T-Series Adaptor Kits 7"	260
W561033	T-Series Adaptor Kits 9"	260
W561034	T-Series Adaptor Kits 12"	260
W561431	Louvre Grilles 6" Grey	266
W561432	Louvre Grilles 7" Grey	266
W561433	Louvre Grilles 9" Grey	266
W561434	Louvre Grilles 12" Grey	266
W563536	Filtered Inlet Grille	264
WA100	100mm Weather Apron (flat roofs)	323
WA160	125mm - 160mm Weather Apron (flat roofs)	323
WA160/20	Weather Apron (pitched roof)	323
WA200	200mm to 250mm '8' to '10' Roof System	323
WA200/20	Weather Apron (pitched roof)	323
WB160	125mm to 160mm Roof Cowl (Standard Colour)	323
WB160C	125mm to 160mm Roof Cowl (Non-standard Colour)	323

Stock Ref	Product	Page
WB200	200mm to 250mm Roof Cowl (Standard Colour)	323
WB200C	200mm to 250mm Roof Cowl (Non-standard Colour)	323
WGZ250	Wire Guards	289
WGZ315	Wire Guards	289
WGZ355	Wire Guards	289
WGZ400	Inlet Wire Guard 400mm dia	289
WGZ450	Inlet Wire Guard 450mm dia	289
WGZ500	Inlet Wire Guard 500mm dia	289
WGZ560	Inlet Wire Guard 560mm dia	289
WGZ630	Inlet Wire Guard 630mm dia	289
WGZ710	Inlet Wire Guard 710mm dia	289
WGZ800	Inlet Wire Guard 800mm dia	289
WRC100	100mm '4' Roof System	323



By Appointment to H.M. The Queen
Suppliers of Unit Ventilation Equipment
Vent-Axia, Crawley, West Sussex

Vent-Axia®

VENT-AXIA CONTACT NUMBERS

Free technical, installation and sales advice is available

Sales Centre:

Domestic & Commercial

Sales Tel: 0844 856 0590
Sales Fax: 01293 565169
Tech Support Tel: 0344 856 0594
Tech Support Fax: 01293 532814

Heating Support

Sales Tel: 0844 856 0590
Tech Support Tel: 0344 856 0594

Industrial

Sales Tel: 0844 856 0591
Sales Fax: 01293 534898
Tech Support Tel: 0344 856 0595
Tech Support Fax: 01293 532814

Web: www.vent-axia.com

Email: sales@vent-axia.com

Supply & Service

All sales made by Vent-Axia Limited are made only upon the terms of the Company's Conditions of Sale, a copy of which may be obtained on request. As part of the policy of continuous product improvement Vent-Axia reserves the right to alter specifications without notice.



A British company supporting British manufacturing
Vent-Axia Group Ltd Products you can trust

402399/0516



FSC
www.fsc.org

MIX

Paper from
responsible sources

FSC® C013417