

# AC Variable Speed Drives For Water & Wastewater Applications

---



The drive for **perfection**

# The IMO Jaguar VXA (Aqua) range...

Specifically designed to fulfil the exacting requirements of the water industry

In close consultation with water industry experts worldwide, the VXA (Aqua) drive has been developed to offer a three-pronged approach to reducing costs and wastage for those in the business of handling water.

## *Reducing Energy Usage*

Whether it is simply a case of reducing speed to suit the demand, automatically stopping a pump during periods of low flow rate or one of the drives specific energy saving functions, energy conservation is always a major consideration in pumping systems.

## *Reducing Downtime*

The IMO Jaguar VXA (Aqua) is a key element in the daily battle to keep plant operational for longer. With features such as anti-jamming, dry pump detection, through to features that reduce startup stresses on both the pumps and the system as a whole. Even the drive itself has been designed with a longer life expectancy.

## *Reducing Wastage & Seepage*

With features such as linearization, which is designed to reduce excessive terminal pressures during periods of low flow and soft pressurizing features, the IMO Jaguar VXA is able to help reduce pipe bursts, water seepage and general stresses on the system.

Inverter Capacity	EMC Filter	DC Reactor	Protective Structure
0.75kW to 90kW	Built-in	Built-in	IP21 / IP55
110kW to 710kW	Built-in	External	IP00

All Drives up to 90kW have integral EMC filter and DCR as standard and are available as IP21 or IP55 thus offering a wide range of installation options.

## *Slim Body*

Same frame size for IP21 and IP55 variants, slim body design allows for compact installation.

## *Specific PUMP Functions*

- Cascading Pump Control
- Dry pump protection
- End of curve protection
- Anti-jam
- Check valve protection
- Slow flow rate protection

## *Additional Functions*

- 4 built-in PID controllers
- Torque vector control
- Programmable Logic Controller
- Password function
- Fire mode (forced operation)
- Real time clock / Timer function
- User friendly, informative keypad

## *Peace Of Mind*

The IMO Jaguar VXA range has a 10 year design life backed by our unique 5 Year Warranty.



## *Optimum control for water and wastewater applications*

### **Water purification plant, wastewater, clean water and sewage treatment plants**

The IMO Jaguar VXA (Aqua) drive has specific water industry features that suit almost all of the applications found within water treatment plants. In addition to accurate process control the VXA can also significantly reduce energy usage and maintenance costs.

### **Pumping stations and pressure boosting stations**

With cascading pump control, 4 built in PID controllers, dry pump detection, condensation prevention and linearization functions the VXA is ideally suited to this type of application. With the built in PLC and real time clock functions and multitude of communication options the drive can be installed as part of a system or used as a stand-alone controller.

### **Irrigation systems**

Sharing many of the same requirements as remote pumping stations the VXA as a stand-alone controller is ideally suited to modern irrigation systems.

### **Blowers**

The VXA is also equipped with many functions that control blowers which are used within water treatment facilities for aeration. These features include automatic energy saving operation and the ability to start onto a rotating load.

### **Other fluid-pressure applications**

The IMO Jaguar VXA (Aqua) has features which are also suited to other fluid handling applications outside of the water industry such as:

- Oil pumping
- CNC coolant pumping
- Injection moulding machines
- Hydraulic presses
- Extruders



## User-friendly, easy-to-read keypad

The following values can be shown on the enlarged LCD display\*

- |                          |                       |
|--------------------------|-----------------------|
| 1. Present value (PV)    | 6. Output voltage     |
| 2. Set value (SV)        | 7. Torque             |
| 3. Manipulate value (MV) | 8. Rotation speed     |
| 4. Frequency             | 9. Power consumption  |
| 5. Output current        | 10. Cumulative energy |

\* User defined process value display options

Multi-language supported: 19 languages + user customised language



## Real-time clock (RTC) provided as standard

Alarm information with date and time.

Previous 10 alarms are stored and displayed with date and time

Timer function:

- Ability to set up to four timers per week.
- Ability to set up to 20 holidays per year.
- Daylight saving feature

**Example:**  
When operation is performed to the same schedule throughout a week

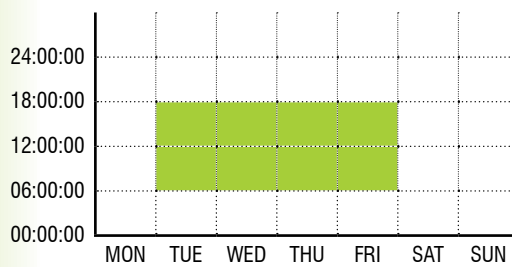

### Example:

The operational schedule can be set using four independent timers when operation requirement varies depending on the day of the week.

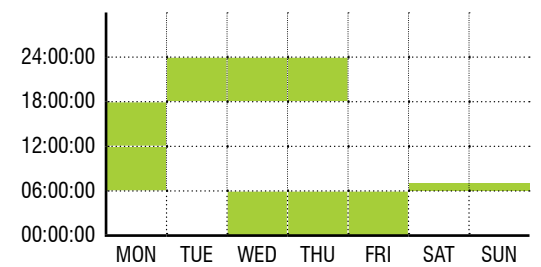

## Unit conversion

Unit conversion function between present value (PV) and set value (SV) values allows you to easily set data

Function	Units			
Unit Conversion	No conversion	%	RPM	l / min
	m³/h	°C	mbar	bar
	kPa	mWG	mmHg	kW
	in-wg	psi	°F	ppm



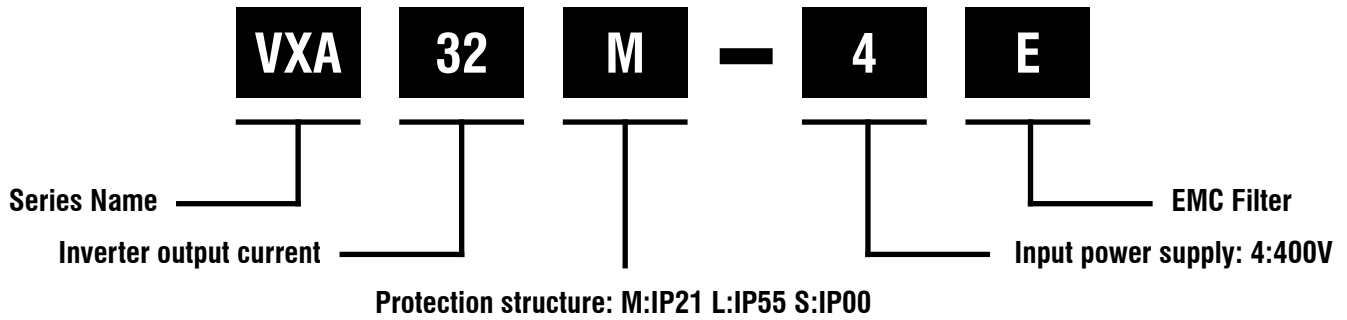

**User-friendly, easy-to-read dedicated keypad**

Multi-language support, HELP function feature, unit setting with SV and PV values, data copy (three types), detachable (can be attached on a control panel using an optional cable)

**Capacitor Board**

Outputs the capacitor life prediction signal determining capacitor level drop and cumulative running hours. This allows the user to determine replacement period

**Control Board**

USB port equipped. Max. three types of built-in optional boards can be mounted at the same time. Optional battery connection for RTC. Various communications option functions

**Control Terminal Block**

A detachable control terminal block design. This allows the control PCB to be replaced easily without disconnecting cables

**Cooling Fan**

Easy replacement just by simply removing and attaching the part. Life expectancy can be increased by controlling ON and OFF

**EMC Filter**

Effectively reduces noise. Integral to units of all capacities. Conforming to IEC61800-3

**DCR**

Effectively reduces harmonic noise. Conforming to IEC/EN61000-3-2 and IEC/EN61000-3-12. Provided as standard (models up to 90kW), and can be attached externally as an option (models from 110kW to 710kW)

**Environmental Immunity**

3C2, IEC60721-3-3 supported

**Others**

Support/analysis by custom built IMO Drive Loader software, RTC backup by battery (option)

Standard Equipment	Optional Equipment	
BACnet MS/TP	LonWorks	DeviceNet
Modbus RTU	Ethernet	CANopen
Metasys N2	Profibus	CC-Link

# Specific Functions for Use in Water Treatment

## Cascade Control

Cascading pump control is the function that controls multiple pumps with one inverter. The pumps are controlled with a combination of inverter drive and mains driven motors. This can be applied in a large-scale water treatment plant.

In cascading pump control, the signals of flow rate and pressure sensors are controlled by the PID controller built into the inverter. Each pump is driven either by the inverter or mains driven motor according to the switching signal from the inverter. The pumps are controlled only by the inverter when the discharge volume is small, the inverter then starts extra pumps one by one by one as the discharge volume increases in order to maintain the required discharge volume.

There are two different methods of control: inverter drive fixed method and inverter drive floating method.

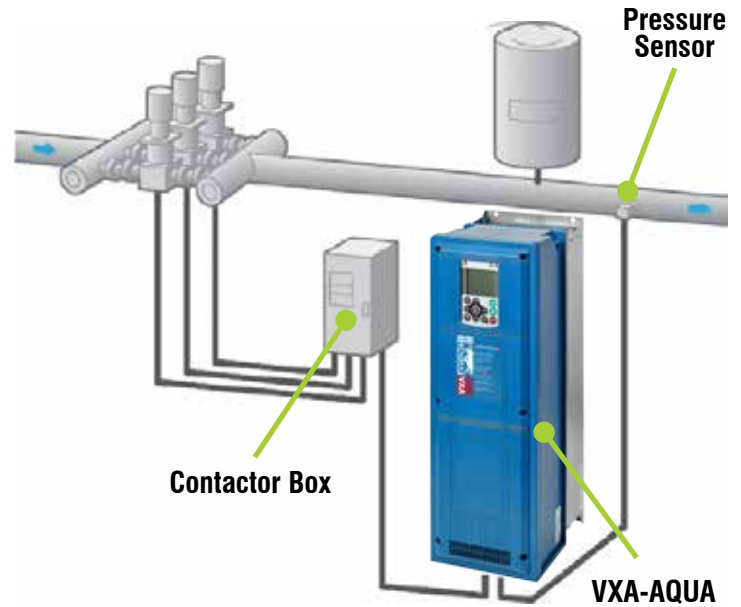

## Inverter drive fixed method (FIXED)

The system for this method is configured by combining the motor driven by the inverter (M0), motors that are mains driven (M1 to M8) and auxiliary motor (MA). The motor driven by the inverter is always fixed as motor M0. Mains driven motors are added one by one when the required discharge flow rate cannot be achieved with motor M0 only.

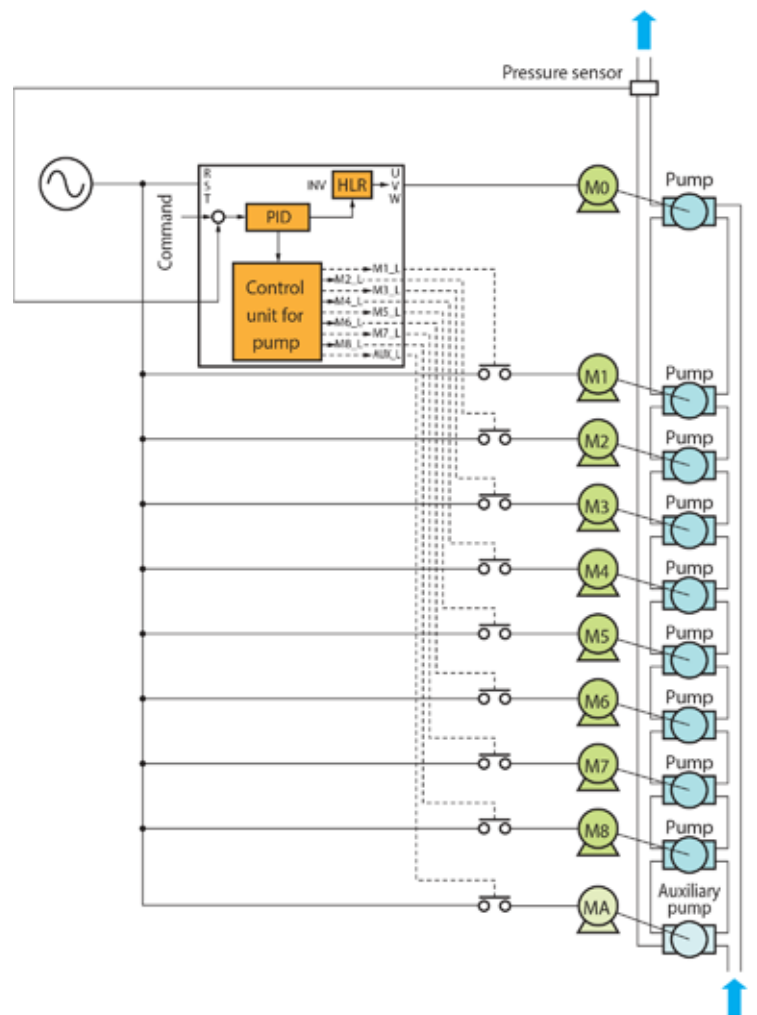

### Inverter drive motor fixed method (FIXED)

**MAX**

**1 Unit**

(Driven by inverter)



**8 Units**

(Mains driven)



**1 Unit**

(Auxiliary motor)

### Inverter drive floating method (FLOATING)

The system for this method is configured by combining the motors that can be switched between inverter drive and mains driven motor (M1 to M4) and auxiliary motor that is mains driven (MA). The motors are driven by the inverter with variable speed control at start. When the desired discharge flow rate cannot be achieved with the first motor, operations FLOATING-1 or FLOATING-2 can be selected.

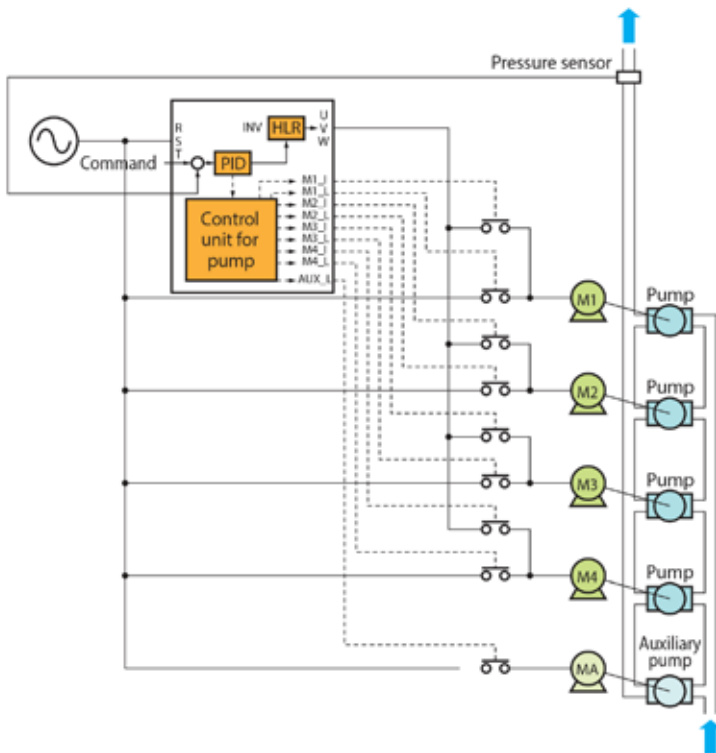

### Inverter drive motor fixed method (FIXED)

**MAX**

**4 Units**



**1 Unit**

(Auxiliary motor)

#### FLOATING-1

The first motor: to be a mains operated motor.  
 Second and subsequent motors: operated by inverter drive  
 The inverter-driven motor is changed by rotation as the motors are added.

#### FLOATING-2

The first motor: remains inverter driven.  
 Second and subsequent motors: Mains driven.

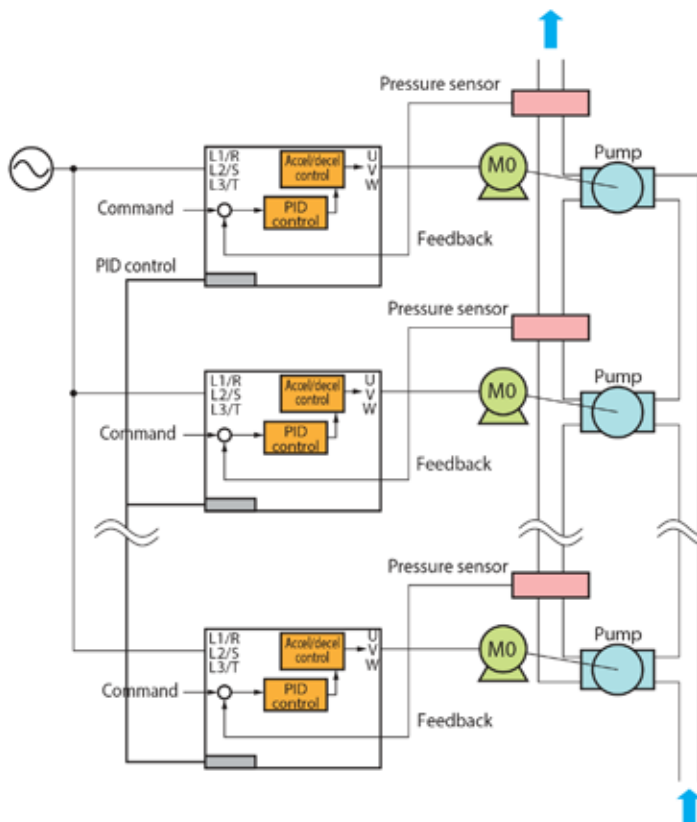

### Mutual Operation

The system can be configured without using a controller by connecting the inverters via communications. In this system if failure occurs to the master inverter, the next inverter is assigned as the master inverter. Wiring can be saved by using the inbuilt Modbus RTU communications.

# Standard Specifications

Item		Specifications																
Model	VXA#**-4E	2A5	4A1	5A5	9	13A5	18A5	24A5	32	39	45	60	75	91	112			
Applicable standard motor (rated output) [kW] <sup>*1</sup>		0.75	1.5	2.2	4.0	5.5	7.5	11	15	18.5	22	30	37	45	55			
Output ratings	Rated capacity [kVA] <sup>*2</sup>	1.9	3.1	4.1	6.8	10	14	18	24	29	34	45	57	69	85			
	Voltage [V] <sup>*3</sup>	3-phase, 380 to 480V (with Automatic Voltage Regulation function)																
	Rated current [A]	2.5	4.1	5.5	9.0	13.5	18.5	24.5	32	39	45	60	75	91	112			
	Overload current rating	110%-1 min (overload tolerated interval: compliant with IEC 61800-2)																
	Rated frequency [Hz]	50, 60Hz																
Input power supply	Main power supply (No. of phase, voltage, frequency)	3-phase, 380 to 480V, 50/60Hz																
	Control power supply auxiliary input (No. of phase, voltage, frequency)	Single phase, 380 to 480V, 50/60Hz																
	Voltage, frequency variations	Voltage: +10 to -15% (Unbalance rate between phases is with 2%) <sup>*4</sup> Frequency: +5 to -5%																
	Rated input current [A]	1.6	3.0	4.3	7.4	10.3	13.9	20.7	27.9	34.5	41.1	55.7	69.4	83.1	102			
	Required power supply capacity [kVA]	1.2	2.1	3.0	5.2	7.2	9.7	15	20	24	29	39	49	58	71			
Braking	Braking torque [%] <sup>*5</sup>	20										10 to 15						
	DC braking	Braking starting frequency: 0.0 to 60.0Hz, Braking time: 0.0 to 30.0s, Braking level: 0 to 60%																
EMC filter		Built-in [Compliant with EMC standard (IEC/EN61800-3:2004)]																
DC reactor (DCR)		Built-in [IEC/EN61000-3-2, IEC/EN61000-3-12]																
Compliant with Electrical Safety Standards		UL508C, C22.2 No.14, IEC/EN61800-5-1:2007																
Enclosure (IEC/EN60529)		IP21 / IP55																
Cooling		Natural cooling							Fan cooling									
Weight / Mass (kg)		IP21 / IP55		10	10	10	10	10	10	10	18	18	18	18	23	23	50	50

Item		Specifications															
Model	VXA#**-4E	150	176	210	253	304	377	415	520	585	650	740	960	1170	1370		
Applicable standard motor (rated output) [kW] <sup>*1</sup>		75	90	110	132	160	200	220	280	315	355	400	500	630	710		
Output ratings	Rated capacity [kVA] <sup>*2</sup>	114	134	160	192	231	287	315	396	445	495	563	731	891	1044		
	Voltage [V] <sup>*3</sup>	3-phase, 380 to 480V (with Automatic Voltage Regulation function)															
	Rated current [A]	150	176	210	253	304	377	415	520	585	650	740	960	1170	1370		
	Overload current rating	110%-1 min (overload tolerated interval: compliant with IEC 61800-2)															
	Rated frequency [Hz]	50, 60Hz															
Input power supply	Main power supply (No. of phase, voltage, frequency)	3-phase, 380 to 480V, 50/60Hz															
	Control power supply auxiliary input (No. of phase, voltage, frequency)	Single phase, 380 to 480V, 50/60Hz															
	Voltage, frequency variations	Voltage: +10 to -15% (Unbalance rate between phases is with 2%) <sup>*4</sup> Frequency: +5 to -5%															
	Rated input current [A]	136	162	201	238	286	357	390	500	559	628	705	881	1115	1256		
	Required power supply capacity [kVA]	95	113	140	165	199	248	271	347	388	436	489	611	773	871		
Braking	Braking torque [%] <sup>*5</sup>	10 to 15															
	DC braking	Braking starting frequency: 0.0 to 60.0Hz, Braking time: 0.0 to 30.0s, Braking level: 0 to 60%															
EMC filter		Built-in [Compliant with EMC standard (IEC/EN61800-3:2004)]															
DC reactor (DCR)		Built-in		Standard accessory (IEC/EN61000-3-2, IEC/EN61000-3-12)													
Compliant with Electrical Safety Standards		UL508C, C22.2 No.14, IEC/EN61800-5-1:2007															
Enclosure (IEC/EN60529)		IP21 / IP55				IP00											
Cooling		Fan cooling															
Weight / Mass (kg)		IP21 / IP55		70	70												
		IP00				62	64	94	98	129	140	245	245	245	330	530	530

\*1) Applicable standard motors are the case for IMO 4-pole standard motors

\*2) The rated capacity indicates the case of 440V ratings

\*3) Output voltage cannot exceed the power supply voltage

\*4) Interphase voltage unbalance ration [%] = max. voltage [V] - min. voltage [V] / 3 phase average voltage [V] x 67 (see IEC61800-3). When unbalance ratio is between 2 and 3% please use optional AC reactor (ACR)

\*5) Average braking torque obtained by use of a motor (varies with the efficiency of the motor)





# Outline Drawing

Basic configuration diagram

(Factory shipped condition: with SOURCE mode input and enable input function)

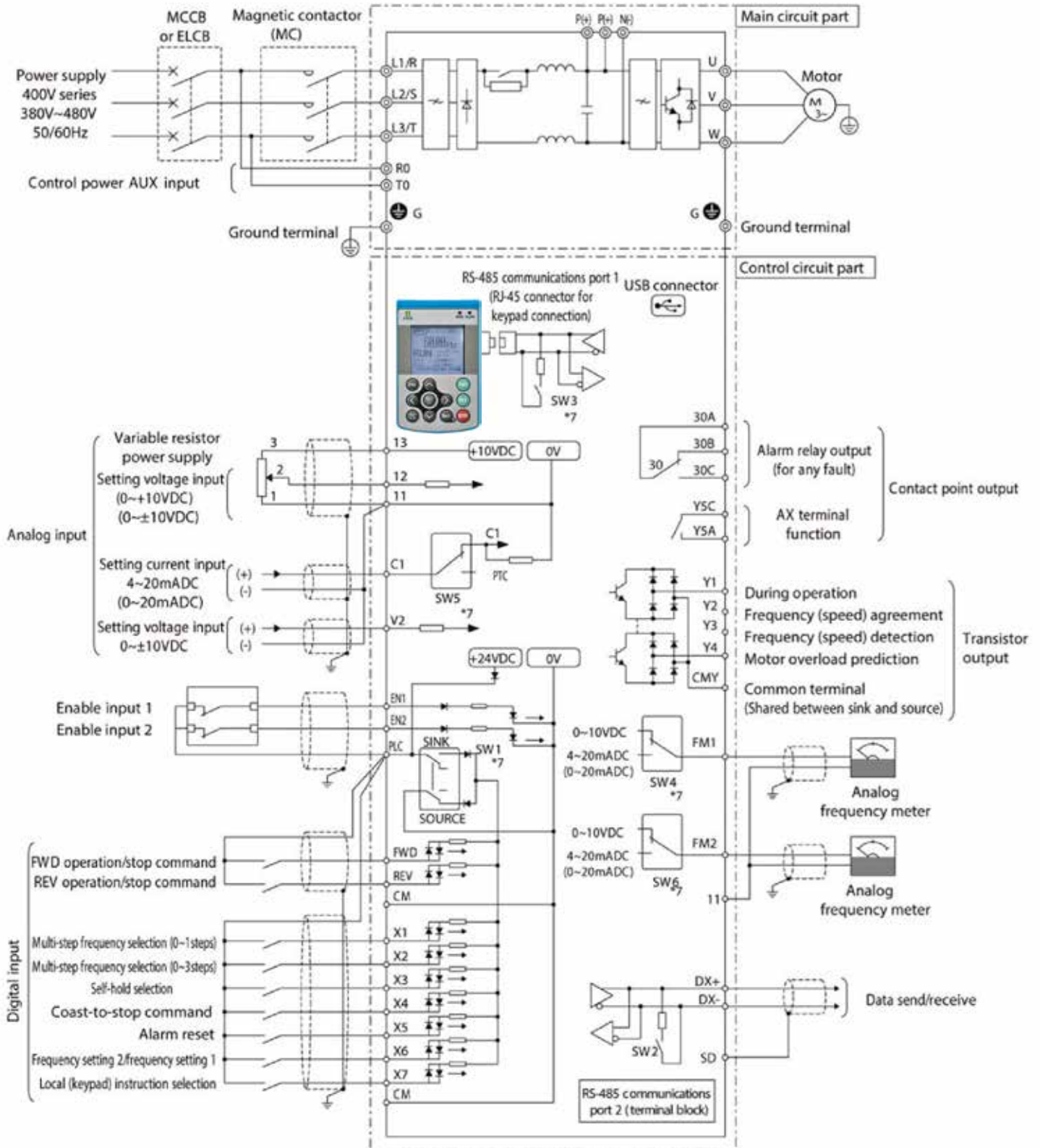

# Options

Description	Part Number
Relay output interface card - 7 Relay NO	OPC-G1-RY
Relay output interface card - 2 Pole C/O	OPC-G1-RY2
Analog input interface card	OPC-G1-AIO
Analog current output interface card	OPC-G1-AO
CC-Link communications card	OPC-G1-CCL
DeviceNet communications card	OPC-G1-DEV
PROFIBUS DP communications card	OPC-G1-PDP
CANopen communications card	OPC-G1-COP
LonWorks communications card	OPC-G1-LNW
Ethernet communications card	OPC-G1-ETH
Pt100 temperature sensor input card	OPC-G1-PT
Battery	OPK-BP

## The Jaguar Range

From our market leading CUB, VXR, VXG, VXH and VXA range of drives with varying functionality and power, IMO has the right frequency inverter to meet the needs of your application, whatever it might be. From a simple small pump or fan through to the most complex large scale hoists, you can be assured that IMO has the drive and the knowledge to meet your application needs.

The IMO CUB features a full range of functions, a compact body, simple operation, wide model variations and global compatibility. It will meet the needs of higher performance machines and equipment such as conveyors, fans, pumps, centrifugal separators and food processing machines, as well as the needs of system integration, energy saving, labour saving and total cost reduction.

With an extended range of functions, the IMO VXR features connectivity, compact body, wide model variations and global compatibility. The VXR with Dynamic Torque Vector Control sets new standards for vector controlled drives. It will meet the needs of high performance machines and equipment such as pumps, fans, conveyors, material handling machines, packaging, special machines and textile machines.

The Building Services specific VXH drive has been designed with energy saving in mind. Equally at home as part of a BMS system with its many inputs and outputs, or as a stand-alone solution with its 4 PID controllers, PLC and real time clock functions.

The VXA or "AQUA" drive has been designed to suit the demands of the water industry where application specific functions cascading pump control, anti-jam and dry pump detection need to be included.

The high performance VXG multi-function inverter boasts state-of-the-art technology, with control performance that has evolved to a new dimension. Control methods now include: PG Vector control, sensorless vector control, dynamic torque vector control and V/F Control. It meets the need of the most demanding drives applications such as hoisting, packaging, material handling, wood, textile and process machinery.



## IMO Worldwide Offices

### IMO Precision Controls Limited

1000 North Circular Road  
Staples Corner  
London NW2 7JP  
United Kingdom

Tel: 020 8452 6444  
Fax: 020 8450 2274  
Email: imo@imopc.com  
Web: www.imopc.com

### IMO Jeambrun Automation SAS

Centre D'Affaires Rocroy  
30, Rue de Rocroy  
94100 Saint-Maur-Des-Fosses  
France

Tel: 0800 912 712 (n° gratuit)  
Fax: 0145 134 737  
Email: imo-fr@imopc.com  
Web: www.imojeambrun.fr

### IMO Automazione

Via Ponte alle Mosse, 61  
50144 Firenze (FI)  
Italia

Tel: 800 930 872 (toll free)  
Fax: 8000 452 6445  
Email: imo-it@imopc.com  
Web: www.imopc.it

### IMO Canada

Unit 32 - B - North  
18 Stratheam Avenue, Brampton  
Ontario L6T 4Y2  
Canada

Tel: 905 799 9237 (local)  
Fax: 905 799 0450  
Email: imo-ca@imopc.com  
Web: www.imopc.com

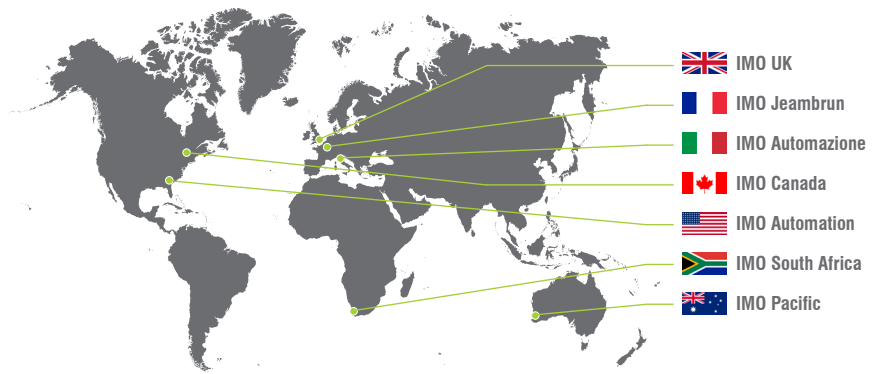

### IMO Automation LLC

101 Colony Park Drive, Suite 300  
Cumming  
Georgia 30040  
USA

Tel: 404 476 8810  
Fax: 404 476 8811  
Email: imo-usa@imopc.com  
Web: www.imoautomation.com

### IMO South Africa (Pty) Ltd

G16 Centurion Business Park  
Montague Gardens  
Cape Town 7441  
South Africa

Tel: 021 551 1787  
Fax: 021 555 0676  
Email: info@imopc.co.za  
Web: www.imopc.co.za

### IMO Pacific Pty Ltd

1/6 Dillington Pass  
Landsdale  
Perth WA 6065  
Australia

Tel: 08 9302 5246 (local)  
Fax: 08 9303 9908  
Email: sales@imopacific.com.au  
Web: www.imopacific.com.au