

TeSyS T Motor Management System

Catalogue

August 2009



TeSys T Motor Management System

- [“TeSys protection components” selection guide page 2](#)
- [General: motor and machine protection page 4](#)
- [“TeSys T Motor Management System” selection guide. page 10](#)
- **TeSys T Motor Management System**
 - [Presentation. page 12](#)
 - [Description. page 14](#)
 - [Functions. page 17](#)
 - [Topology page 19](#)
 - [Programming page 21](#)
 - [Characteristics. page 23](#)
 - [Tripping curves. page 27](#)
 - [References page 28](#)
 - [Dimensions, mounting page 32](#)
 - [Schemes page 34](#)
 - [Combinations for customer assembly page 38](#)
 - [Substitution table page 40](#)

Applications

Motor protection

Thermal motor protection



Protection

- Motor overload
- Stalling
- Phase failure

Tripping class

Class 10 A	Classes 10 A and 20	Classes 10 and 20
------------	---------------------	-------------------

Communication

–

Used with contactor type

LC1 K, LP1 K	LC1 D	LC1 F
--------------	-------	-------

Motor current (In)

0.11...16 A	0.1...150 A	30...630 A
-------------	-------------	------------

Relay or controller type

LR2 K	LRD, LR2 D and LR9 D	LR9 F
--------------	-----------------------------	--------------

Pages

Please consult our catalogue "Control and protection components".

Machine protection

Motor and machine protection

Protection of slip ring motors and of circuits without current peaks

Protection of resistors, bearings, capacitors

Specific motor protection

Protection and control



- Strong overcurrent
- Stalling

- Frequent starting
- Harsh environments

- Overtorque
- Mechanical shocks
- Locked rotor
- Phase failure

- Overtorque
- Mechanical shocks

- Thermal overload
- Phase imbalance and phase failure
- Motor stalling
- Long starting times
- Earth fault

- Thermal overload
- Phase imbalance and phase failure
- Locked rotor
- Long starting times
- Phase reversal
- Earth fault

-

Classes 5 to 30

Classes 5 to 30

-

Modbus, CANopen, DeviceNet, Profibus DP, Advantys STB, AS-Interface

Modbus, CANopen, DeviceNet, Profibus DP, Ethernet TCP/IP

All contactors

0.7...630 A

Unlimited

0.3...38 A

0.3...60 A

0.35...800 A

0.4...810 A

RM1 XA

LT3 S

LR97D

LT47

LUTM 00BL

LTM R

Please consult our catalogue "Control and protection components".

Please consult our catalogue "TeSys U Starter-controllers".

28

Introduction

Exceeding the operating limits of an electric motor will lead, eventually, not only to destruction of the motor itself but also of the mechanisms it drives.

This type of load can be the cause of electrical or mechanical faults.

■ **Electrical faults:**

- overvoltage, voltage drop, imbalance and phase failure which cause variations in the current drawn,
- short-circuits which can cause the current to reach levels capable of destroying the load.

■ **Mechanical faults:**

- locked rotor,
- brief or prolonged overload which leads to an increase in the current drawn by the motor, and therefore overheating.

The cost of these faults must take into account loss of production, loss of raw materials, repair of the production tool, poor quality of production and delays in delivery.

These faults can also have dramatic consequences on the safety of persons in direct or indirect contact with the motor.

To prevent these faults, protection measures are necessary. They make it possible to isolate the equipment to be protected from the mains supply by measuring variations in electrical values (voltage, current, etc...).

Each motor starter must therefore have:

■ **short-circuit protection**, to detect and break, as quickly as possible, abnormal currents generally greater than 10 times the rated current (I_n).

■ **overload protection**, to detect increases in current up to about $10 I_n$ and switch off the starter before overheating of the motor and conductors damages the insulation.

This protection is provided by specific devices such as fuses, circuit-breakers and thermal overload relays, or by more integrated devices offering several types of protection.

Causes, effects and consequences of various faults

There are two types of fault:

- Internal faults within the motor.
- External faults: these are located outside the electric motor but their consequences can lead to damage inside the motor.

Faults	Causes	Effects	Consequences on the motor and on the machine
Short-circuit	Contact between several phases, or between one phase and neutral or between several turns of the same phase.	<ul style="list-style-type: none"> ■ Current peak ■ Electrodynamical forces on the conductors 	Destruction of windings
Overvoltage	<ul style="list-style-type: none"> ■ Lightning ■ Electrostatic discharge ■ Operation 	Dielectric breakdown in the windings	Destruction of the windings due to loss of insulation
Phase imbalance and phase failure	<ul style="list-style-type: none"> ■ Opening of a phase ■ Single-phase load upstream of the motor ■ Short-circuit between the turns of the same winding 	<ul style="list-style-type: none"> ■ Reduction of usable torque, efficiency and speed ■ Increase in losses ■ Starting impossible if phase failure 	Overheating (1)
High starting frequency	<ul style="list-style-type: none"> ■ Failure of the automation system ■ Too many manual control operations ■ Numerous fault trips 	High stator and rotor temperature rise due to the frequent start current	Overheating (1) Consequences on the process
Voltage variations	<ul style="list-style-type: none"> ■ Instability of the mains voltage ■ Connection of heavy loads 	<ul style="list-style-type: none"> ■ Reduction of usable torque ■ Increase in losses 	Overheating (1)
Harmonics	■ Pollution of the mains supply by variable speed drives, inverters, etc...	<ul style="list-style-type: none"> ■ Reduction of usable torque ■ Increase in losses 	Overheating (1)
Long starting time	<ul style="list-style-type: none"> ■ Resistive torque too high (load too heavy) ■ Voltage drop 	Increase in starting time	Overheating (1)
Jamming	<ul style="list-style-type: none"> ■ Mechanical problem (crusher) ■ Seizures 	Overcurrent	Overheating (1) Consequences on the process
No-load running	<ul style="list-style-type: none"> ■ Pump running empty ■ Mechanical break in drive to the load 	Drop in current drawn	Consequences on the process
Frequency fluctuations	<ul style="list-style-type: none"> ■ Overload of a supply powered by limited independent sources ■ Faulty alternator speed regulator 	<ul style="list-style-type: none"> ■ Increase in losses ■ Interferes with synchronous devices (clock, recorder, ...) 	–
Overload	<ul style="list-style-type: none"> ■ Increase in resistive torque ■ Voltage drop ■ Drop in power factor 	Increase in current consumption	Overheating (1)
Loss of machine excitation	<ul style="list-style-type: none"> ■ Significant drop in excitation current ■ Break in rotor winding 	<ul style="list-style-type: none"> ■ Increase in active power ■ Drop in power factor 	Significant overheating of rotor and cage
Phase-Earth fault	<ul style="list-style-type: none"> ■ Accidental Phase-Earth contacts ■ Accidental Phase-machine casing contacts (casing connected to earth) 	<ul style="list-style-type: none"> ■ Overvoltage developed in the mains supply ■ Rise in earth potential (safety of persons) 	Consequences on safety of persons

(1) Then, in the longer or shorter term, depending on the seriousness of the fault and/or its frequency, short-circuit and destruction of the windings.

Protection functions

Short-circuit protection

General

A short-circuit results in a very rapid rise in current which can reach several hundred times the value of the operational current. The consequences of a short-circuit are dangerous to both equipment and persons. It is therefore imperative to use protection devices to detect the fault and very quickly break the circuit.

Two types of protection are commonly used:

- fuses (cutout) which break the circuit by melting, which then requires their replacement,
 - magnetic trip circuit-breakers, often more simply called "magnetic circuit-breakers", which only require re-setting to put them back into service.
- Short-circuit protection can also be built-into multifunction devices such as motor circuit-breakers and contactor-breakers.

The main characteristics of short-circuit protection devices are:

- their breaking capacity: this is the highest prospective short-circuit current value that a protection device can break at a given voltage.
 - their making capacity: this is the highest current value that the protection device can make at its rated voltage in specified conditions.
- The making capacity is equal to k times the breaking capacity.

Fuses (cutouts)

Fuses provide individual phase protection (single-pole), with a high breaking capacity in a compact size:

- mounted either in fuse carriers,
- or in isolators, replacing the original links or shunt bars.

For motor protection, aM type fuses are used. Their design characteristics allow them to conduct the high magnetising currents that occur when motors are switched on. They are therefore unsuitable for overload protection (unlike gG type fuses). This is why an overload relay must be included in the motor power supply circuit.

Magnetic circuit-breakers

These circuit-breakers protect installations against short-circuits, within the limit of their breaking capacity.

Magnetic circuit-breakers provide omnipole breaking as standard.

For relatively low short-circuit currents, the operation of a circuit-breaker is faster than that of fuses.

This protection conforms to standard IEC 60947-2.

The thermal and electrodynamic effects are also limited, therefore ensuring better protection of cables and equipment.



LS1 D32
fuse carrier

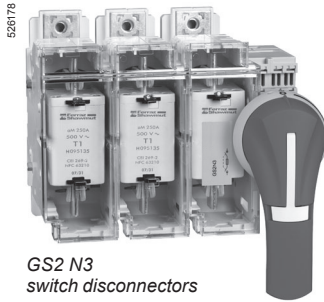

GS2 N3
switch disconnectors



GV2 L
magnetic circuit-breaker



TeSys U
LUB 12 power base with
LUCA control unit

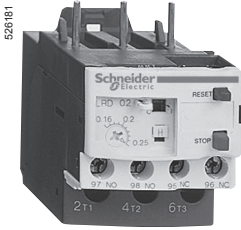

LRD 02
thermal overload relay



LRD 365
thermal overload relay



RM4 JA current measurement relay



TeSys U starter-controller with "thermal overload alarm" function module

Protection functions (continued)

Overload protection

General

An overload condition is the most frequently encountered fault. The symptoms are a rise in the current drawn by the motor and thermal effects. A rapid return to normal operating conditions is important.

The actual operating conditions (ambient temperature, operating altitude and type of standard duty) are essential to determine the operating values of the motor (power, current) and to be able to select effective overload protection. These operational values are given by the motor manufacturer.

According to the level required, protection can be provided by:

- overload relays and thermal overload relays (bi-metallic or electronic type) which protect motors in the event of:
 - overload, by monitoring the current drawn by each phase,
 - phase imbalance or failure, by their differential mechanism.
- relays with PTC thermistor probes (Positive Temperature Coefficient).
- overtorque relays,
- multifunction relays.

Overload relays

These relays protect motors against overload. They must allow the temporary overload that occurs on starting and must only trip if the starting time is abnormally long.

The overload relay will be selected according to the length of the starting time (tripping class) and the motor rating.

These relays have a thermal memory (except for certain electronic overload relays, indicated by their manufacturers) and can be connected:

- either in series with the load,
- or to current transformers placed in series with the load.

Bi-metallic thermal overload relays

Combined with a contactor, these relays protect the line and the equipment against small and prolonged overloads. They must be protected against strong overcurrent by a circuit-breaker or fuses.

These relays may be used on an a.c. or d.c. system and are generally:

- 3-pole,
- compensated, i.e. insensitive to ambient temperature variations,
- with manual or automatic reset,
- graduated with a "motor FLC" scale: allowing direct setting to the full load current as shown on the motor rating plate.

They can also be sensitive to phase failure: this is known as 'differential'. This function conforms to standards IEC 60947-4-1 and 60947-6-2

This type of relay is extremely reliable and is a relatively low cost device.

Electronic thermal overload relays

Electronic thermal overload relays have the advantage of electronics which allow a more complex thermal image of the motor to be created.

They can be combined with products having complementary functions, such as:

- temperature sensing via PTC probes,
- protection against jamming and overtorque,
- protection against phase reversal,
- earth fault protection,
- protection against no-load running,
- alarm function.



LT3 S
relays for use with
thermistor probes



LR97 D07
instantaneous electronic
overcurrent relays



TeSys U
starter-controller LUB 32
with multifunction control
unit LUC M



TeSys U controller
LUTM 20BL



TeSys T controller
LTM R08MBD

Protection functions (continued)

Overload protection (continued)

Relays for use with PTC thermistor probes

With direct sensing of the stator windings, these relays can be used to protect motors against:

- overload,
- a rise in ambient temperature,
- a ventilation circuit fault,
- a high starting frequency,
- mechanical shocks, etc...

Overload (or overtorque) relays

These relays protect the drive line in the event of a locked rotor, seizure or mechanical shocks. This is an additional protection.

Unlike thermal overload relays, these relays do not have a thermal memory. They have definite time characteristics (adjustable current threshold and time delay).

The overtorque relay can be used as overload protection for motors with long starting times or very frequent starting (for example, lifting hoists).

Multifunction relays

■ Overcurrent relays are limited when it is necessary to take into account problems associated with voltage, temperature or special applications. New production or maintenance management needs have prompted manufacturers to offer products which provide not only adaptable protection, but also complete management of the motor and its load.

They incorporate:

- current and voltage sensors (TeSys T controllers),
- hybrid analog and digital electronic technology,
- the use of communication buses for data exchange and control,
- powerful motor modelling algorithms,
- integrated application programs whose parameters can be set.

These products make it possible to reduce installation and operating costs by reducing maintenance and downtime.

TeSys U starters:

The multifunction relay is incorporated in the motor starter.

This solution is very compact with reduced wiring. It is limited to 32 A.

TeSys U controllers:

The multifunction relay is separate from the power line and reuses the function blocks from the TeSys U solution. It can be used in conjunction with a contactor up to 810 A.

TeSys T controllers:

The multifunction relay is separate from the power line and incorporates inputs and outputs. It can be used in conjunction with a contactor up to 810 A.

Protection components

Motor and machine protection

Protection relay selection table					
Relay type	Motor protection		Machine protection	Motor and machine protection	
	Thermal overload relay	Relays for use with PTC probes	Overtorque relays	TeSys U controller	TeSys T controller
	LR2 K, LRD, LRD 3, LR9 F, LR9 D (1)	LT3 S	LR97 D, LT47	LUT M	LTM R
Causes of overheating	(2)		(2)	(2)	(3)
Slight overload	■	■	■	■	■
Locked rotor	■	■	■	■	■
No-load running	■	■	■	■	■
Supply phase failure	■	■	LR9 7D	■	■
Ventilation fault	■	■	■	■	With probes
Abnormal temperature rise	■	■	■	■	With probes
Shaft bearing seizure	■	■	■	■	With probes
Insulation fault	■	■	■	■	■
Protracted starting time	■	■	■	■	■
Severe duty	■	■	■	■	With probes
Voltage variation	■	■	■	■	■
Frequency fluctuations	■	■	■	■	■
Loss of machine excitation	■	■	■	■	■

- Ideally suited
- Possible solution
- Not suitable (no protection)

(1) for motor circuit-breaker type GV2ME.
 (2) Protection based on current.
 (3) Protection based on current and voltage.

Applications

Multifunction motor and machine protection

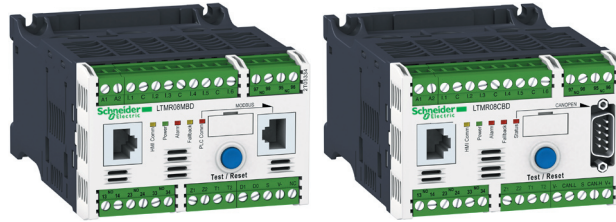

Device type

Controllers

For network/bus

Modbus	CANopen	DeviceNet	Profibus DP	Ethernet TCP/IP
--------	---------	-----------	-------------	-----------------

Current range

0.4...100 A (with internal current transformer)
100...810 A (with external current transformer)

Control voltage

⎓ 24 V
~ 100...240 V

Number of I/O

6 inputs
4 outputs

Measurements

- Current between phases
- Earth fault.
- Motor temperature.

Functions

- Protection and monitoring functions:**
- thermal overload,
 - motor temperature monitoring,
 - phase imbalance and phase failure,
 - locked rotor,
 - long starting times,
 - phase reversal,
 - earth fault.

Device type

LTM R●●M●●	LTM R●●C●●	LTM R●●D●●	LTM R●●P●●	LTM R●●E●●
------------	------------	------------	------------	------------

Pages

28



Input extension modules,
for all LTM R controllers

Operator control unit

–

–

–

–

≡ 24 V (1)

~ 100...240 V (1)

Powered via the LTM R controller or via the LTM E extension module.

4 independent inputs

–

Voltage between phases

–

Monitoring functions:
- voltage,
- power,
- Cos φ (power factor)

Display functions:
- measurements,
- faults and alarms,
- statistics, etc...

LTM EV40BD

LTM EV40FM

LTM CU

29

29

(1) Input control voltage. The electronics are powered via the controller.

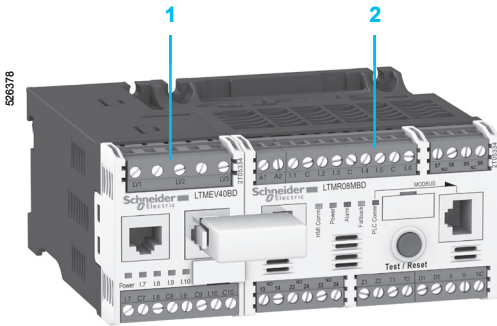

- 1 LTM EV40BD extension module
- 2 LTM R08MBD controller

Presentation

TeSys T is a motor management system that provides protection, metering and monitoring functions for single-phase and 3-phase, constant speed, a.c. motors up to 810 A.

Suitable for the harshest applications, this product range offers:

- high-performance multifunction protection, independent of the automation system,
- a local HMI control unit for reading, displaying and modifying the parameters monitored, diagnostics, etc.....
- configuration of the application using PowerSuite software,
- connection to the automation system via a communication network (selection according to various protocols).

Application

The TeSys T motor management system is used for motor control and protection in harsh industrial applications, in which downtime must be avoided because it is very costly: Oil & Gas, chemical industry, water treatment, metal, minerals and mining, pharmaceutical industry, microelectronics, tunnels, airports etc.

With TeSys T, untimely stoppages of a process or manufacturing, associated with a motor, are anticipated via predictive analysis of fault situations. Fault tripping is therefore reduced to a minimum.

Its use in motor control panels makes it possible to:

- increase the operational availability of installations,
- improve flexibility from project design through to implementation,
- increase productivity by making available all information needed to run the system.

The TeSys motor management system integrates perfectly with Schneider Electric low voltage equipment, such as Okken, Blokset and Prisma.

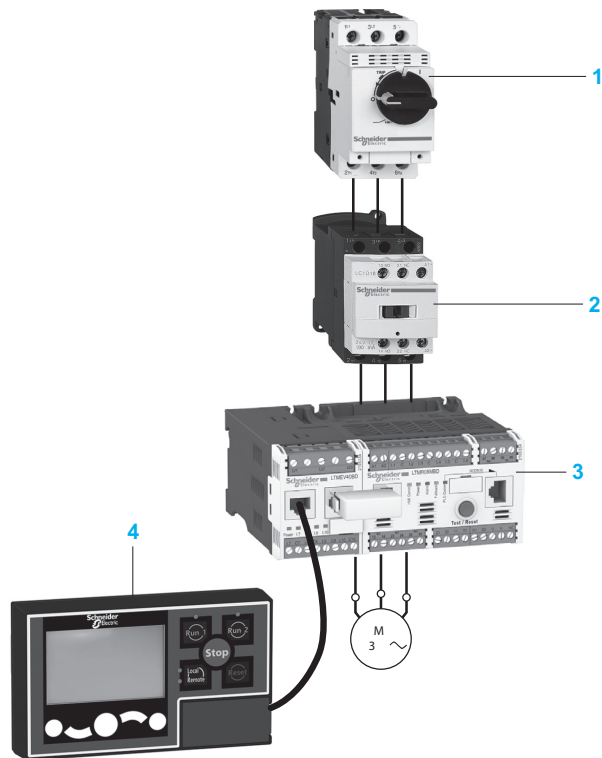

- 1 Magnetic circuit-breaker
- 2 Contactor
- 3 Controller with extension module
- 4 Operator control unit

526379

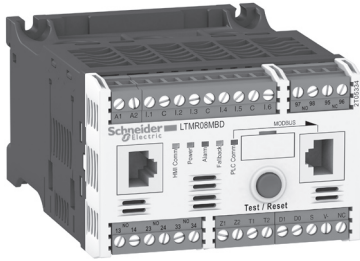

LTM R08MBD

526380

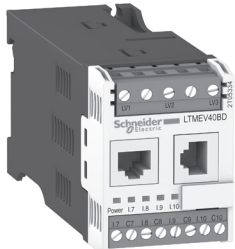

LTM EV40BD

568605



LTM CU

Presentation (continued)

Composition of the motor management system

The system comprises:

- an LTM R motor management controller
 - with integral current transformer up to 100 A,
 - above 100 A, by external current transformer up to 810 A,
- an LTM E extension module,
- an LTM CU operator control unit,
- configuration software incorporated in the PowerSuite software application,
- accessories for system set-up.

Communication

The LTM R controller is equipped with a communication interface to allow remote monitoring and control of the motor. All motor information is then available at automation system level.

The following networks are available:

- Modbus, CANopen, DeviceNet, ProfiBus DP and Ethernet TCP/IP.

TeSys T system functions

Protection functions:

- against thermal overload,
- against phase imbalance and phase failure,
- thermal motor protection via PTC probes,
- against phase reversal,
- against earth faults,
- against long starting times and motor stalling,
- against automatic load shedding and restarting,
- against load fluctuations (I, U, P),
- against variations of Cos φ (power factor).

Metering functions

- Measurements (rms values):
 - current on the 3 phases,
 - voltage on the 3 phases (shedding),
 - motor temperature,
 - earth fault,
- Values calculated:
 - average current,
 - frequency,
 - Cos φ (power factor), power, power consumption...

Motor control functions

A motor managed by TeSys T can be controlled:

- locally, using the logic inputs present on the product, or via the HMI terminal
- remotely, via the network (connection by terminal block or connector except for DeviceNet: terminal block only).

Motor control modes

5 predefined motor control modes are incorporated in the controller:

- overload mode: monitoring of motors whose control is not managed by the controller,
- independent mode: starting of non-reversing motors,
- reverser mode: starting of reversing motors,
- 2-step mode: 2-step starting of motors (star-delta, by autotransformer and by resistor),
- 2-speed mode: 2-speed starting of motors (Dahlander, pole changer).

A 6th "Custom" mode is available to allow the user to create a specific motor control mode that is not predefined in the controller.

Statistical and diagnostic functions

- fault statistics: counters per type of protection and history of the last 5 faults,
- motor statistics: saving of motor statistics values,
- diagnosis of faults affecting correct operation of the product.

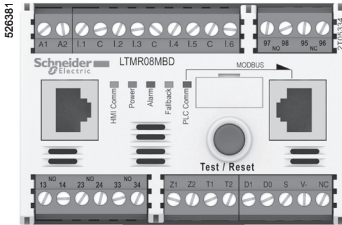

LTM R●●

Description

The LTM R controller

The controller is the central component in the motor management system. It manages the basic functions such as:

- measurement of 3-phase current via integral current transformers from 0.4 to 100 A (up to 810 A by external current transformers),
- measurement of earth current by external earth fault toroid.
- measurement of motor temperature by PTC probe,
- inputs and outputs for the various motor control modes, fault management and associated functions.

Characteristics

As standard, the controller manages the following predefined control mode functions:

- overload mode,
- independent mode,
- reverser mode,
- 2-speed mode,
- 2-step mode,
- "Custom" mode.

Supply

2 types of controller power supply are available:

- $\overline{\text{---}}$ 24 V,
- \sim 100...240 V.

Current ranges

3 current ranges allow measurement of motor current from 0.4 to 100 A:

- 0.4...8 A,
- 1.35...27 A,
- 5...100 A.

For use with external current transformers, choose the 0.4...8 A range (1 or 5 A current transformer secondary).

Inputs

- 6 discrete logic inputs.

Outputs

- 3 relay logic outputs (1N/O)
- 1 relay output for fault signalling (1N/O + 1N/C))

Measurements

- connections for a temperature probe,
- connections for an earth fault toroid.

LTM E extension module

The extension module adds the following functionalities to the TeSys T controller:

- voltage measurement on the 3 phases. This enables it to calculate numerous engine monitoring parameters (power, frequency, $\text{Cos } \varphi$...),
- 4 additional inputs.

Characteristics

Inputs

- 4 discrete logic inputs (independent).

Power supplies

- 2 types of power supply for the inputs: $\overline{\text{---}}$ 24 V and \sim 100...240 V.

A $\overline{\text{---}}$ 24 V controller can be assembled with an \sim 100...240 V extension module and vice versa.

Voltage measurement between phases up to 690 V nominal.

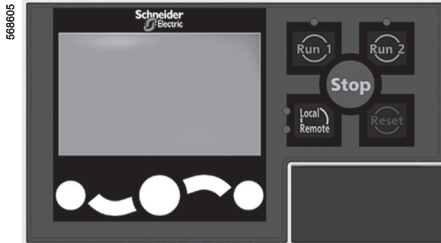

LTM CU

Description (continued)

Human/Machine Interfaces (HMI)

Depending on the application, 2 types of HMI can be used with the LTM R controller.

- The LTM CU operator control unit:
 - Entirely dedicated to the TeSys T range,
 - Only for control/monitoring of an LTM R controller.
- A Magelis XBT N410 terminal
 - For control/monitoring of 1 to 8 LTM R controllers.

LTM CU operator control unit

Dedicated exclusively to TeSys T controllers, control unit LTM CU makes it possible to:

- Configure the parameters of the LTM R controller
- Display information on controller configuration and operation.
- Monitor the alarms and faults generated by the controller.
- Local control of the motor via the local control interface (keys can be customised). Three different languages can be loaded into the LTM CU controller at the same time.

By default, these 3 languages are: English, French and Spanish.

Note: *English is the only compulsory language.*

A language download utility (LangTool), together with all the other languages, are available on the website "www.schneider-electric.com".

This tool allows the languages present in the LTM CU control unit to be adapted.

The LTM CU HMI control unit has an RJ45 port, protected by a flexible cover to provide a good level of protection (IP54).

This port on the front panel allows connection to a PC, via a connecting cable, in order to use PowerSuite software.

In this case, the control unit acts as a transmitter and all information can then be viewed in PowerSuite.

The Magelis XBT N410 HMI terminal

Two applications have been predefined for TeSys T. Depending on the application loaded, the HMI terminal makes it possible to:

- configure and monitor a motor starter (LTM_1T1_V1.dop).
- monitor and modify certain parameters on up to 8 motor starters (LTM_1T8_X_V1.dop) (1).

XBT L1000 programming software is needed for loading applications into the HMI terminal.

These applications are available on the website "www.schneider-electric.com".

(1) Replace the X with an E for the English version, or an F for the French version.

LTM R controllers

Modbus

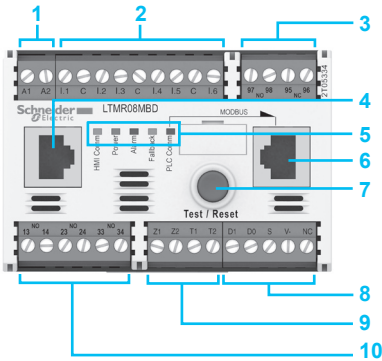

DeviceNet

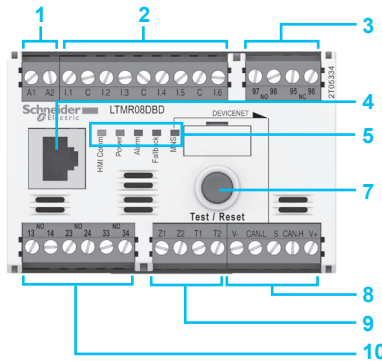

Profibus DP

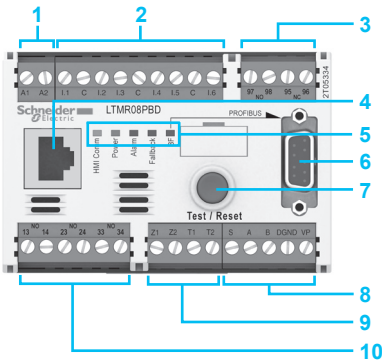

CANopen

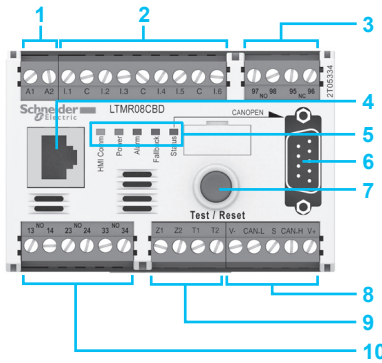

Ethernet TCP/IP

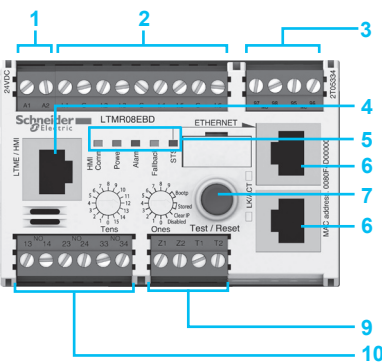

LTM EV40 extension modules

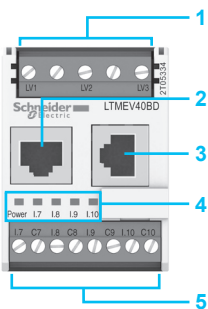

Extension modules have the following on their front face:

- 1 Inputs for voltage measurement.
- 2 Port for connection to the HMI terminal or to the PC.
- 3 Port for connection to the controller.
- 4 Extension module status LEDs.
- 5 Connection of additional inputs.

LTM CU operator control unit

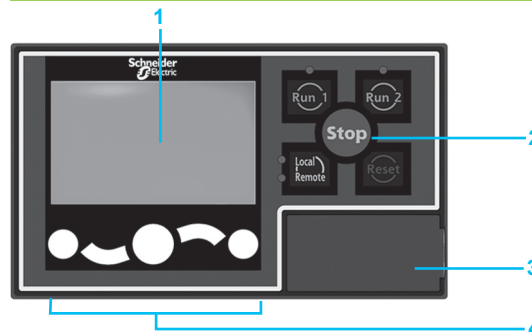

The control unit has the following on its front face:

- 1 Screen. LCD display
- 2 Local control interface including control keys and LEDs.
- 3 RJ45 port on front panel for connection to a PC (protected by a cover).
- 4 Contextual navigation keys.

Controllers feature the following on their front panel:

- 1 Controller power supply.
- 2 Input connections.
- 3 Fault outputs (N/O+N/C).
- 4 Port for connection to the HMI terminal, a PC or an extension module (RJ45).
- 5 Controller status LEDs.
- 6 Network port for connection to the network by connector (except DeviceNet) (1).
- 7 Test/Reset button.
- 8 Connection to the network by terminal block (except Ethernet TCP/IP).
- 9 Connection for an earth fault toroid and temperature probes.
- 10 Outputs for motor control mode function.

(1) Connection using power extension (daisy-chaining) is possible for Ethernet TCP/IP.

Thermal and current protection functions					
Functions	Setting range	Controller LTM R	Controller and extension module (LTM R + LTM E)	Alarm threshold	Fault threshold
Description					
Thermal overload: thermal protection of motor by monitoring current consumption	Class: 5, 10, 15, 20, 25, 30. Inverse ther/definite time				
Motor temperature: thermal monitoring of the motor using temperature probes (winding, paper...). Up to 3 sensors in series.	PTC binary PTC/NTC analogue: 20 ...6500 Ohm				
Phase imbalance: monitors the symmetry of currents. To be used for imbalance < 80% of the average current (1).	10...70% I average 0.2...20 s				
Phase failure: monitors the symmetry of currents. To be used for imbalance < 80% of the average current (1).	0.1...30 s				
Phase reversal: signals when the phase sequence is different from the defined sequence (motor running).	A-B-C A-C-B				
Long starting time: monitors the motor starting time	100...800 % of FLC (2) 1...200 s				
Locked rotor: locking detected by a sudden increase in current after the start phase	100...800 % of FLC (2) 1...30 s				
Min/max current load limit variations: monitors motor load through variations of current around preset thresholds.	min.: 30...100 % of FLC (2) 1...200 s max.: 20...800 % of FLC (2) 1...250 s				
Earth fault: signals internal insulation faults, by vectorial summing of external currents, via earth fault toroid.	internal: 20...500 % min FLC (2) 0.05...25 s external: 0.02...10 A 0.05...25 s				
Frequent starting: Protects the motor against overheating due to frequent starting.	0...999.9 s				
Voltage and power protection functions					
Phase imbalance: monitors the symmetry of voltage between phases. To be used for imbalance < 40 % of the average voltage (3).	3...15 % 0.2...20 s				
Phase failure: monitors the symmetry of voltage between phases. To be used for imbalance > 40 % of the average voltage (3).	0.1...30 s				
Phase reversal: signals when the phase sequence is different from the defined sequence (motor stopped).	A-B-C A-C-B				
Voltage variations. Min/max voltage limits: monitors voltage variations around preset thresholds.	min.: 70...99 % 0.2...25 s max.: 101...115 % 0.2...25 s				
Load shedding: opens outputs O.1 and O.2 if voltage drops below a preset threshold.	68...115 % 1...9999 s				
Power variations. Min/max power limits: monitors power variations around preset thresholds.	20...800 % 0...100 s				
Variations of Cos φ. Min/max limits of Cos φ : monitors variations of Cos φ around preset thresholds.	0...10...25 s				

 Function performed.

(1) Average current value measured on the 3 phases.
(2) FLC: Full Load Current (setting current).
(3) Average voltage value measured on the 3 phases.

Motor control functions				
Functions	Description		With controller LTM R	With controller LTM R and extension module LTM E
Control modes	Local, via terminal block		X	X
	Local, via HMI terminal (1)		X	X
	Remote, via network		X	X
Operating modes	Overload		X	X
	Independent		X	X
	Reverser		X	X
	2-step		X	X
	2-speed		X	X
	"Custom" mode		X	X
Fault management	Manual reset		X	X
	Automatic reset		X	X
	Remote reset		X	X
Metering functions and statistics				
Functions	Description	Measurement range	With controller LTM R	With controller LTM R and extension module LTM E
Measurements (2)	Current/Phase	0.08...1000 A	X	X
	Earth current	0.1633 x CT ratio	X	X
	Average current	0.08...1000 A	X	X
	Current imbalance between phases	0...200 %	X	X
	Thermal capacity level	0...200 %	X	X
	Motor temperature rise	0...6500 Ohm	X	X
	Frequency	0... 100 Hz		X
	Voltage between phases	~ 0...830 V		X
	Voltage imbalance between phases	0...200 %		X
	Active power	0...6553.5 kW		X
	Reactive power	0...6553.5 kW _r		X
	Cos φ (power factor)	0...100		X
	Active power consumption	0...400 kWh		X
	Reactive power consumption	0...400 kWh _r		X
Fault statistics	Protection fault counters		X	X
	Protection alarm counters		X	X
	Diagnostic fault counters		X	X
	Motor control function counters		X	X
	Fault history		X	X
Fault diagnostics	Internal watchdog fault		X	X
	Controller internal temperature		X	X
	Temperature sensor connection		X	X
	Current connection		X	X
	Voltage connection			X
	Motor control commands (start, stop, run check back and stop check back)		X	X
	Control configuration checksum		X	X
Loss of communication		X	X	
Motor statistics	Number of motor control commands (O.1/O.2 starts)		X	X
	Operating time		X	X
	Number of starts/hour		X	X
	Last start I max.		X	X
	Duration of last start		X	X
Thermal overload statistics	Time to trip		X	X
	Time to restart		X	X
System operating statistics	Run, ON, Start, alarm, fault.		X	X

(1) HMI: Human Machine Interface.
See measurement details page 24.

Service classes offered by the Ethernet TCI/IP version

Class	A 20 ETH10/100 + FTP server	
Basic Web server	None	
Basic communications services	Modbus messaging (read/write of data words)	
Ethernet TCP/IP communication advanced management services	I/O Scanning	Yes
	Global Data	No
	Client FDR (1)	Automatic monitoring and updating of product parameter configuration. Automatic assignment of IP address and network parameters.
	SNMP network administrator (2)	Yes

Ethernet: different network topologies

Star topology

In a star topology, all the peripherals are linked via an intermediate peripheral (hub or switch)..

In industrial Ethernet applications, the use of full duplex switches (instead of hubs) as central peripherals is strongly recommended.

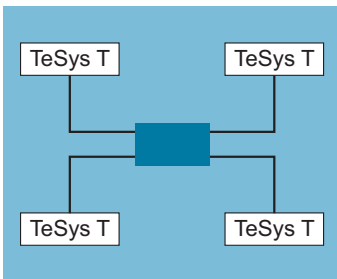

Star topology

Power extension (Daisy chain) topology

Power extension (or *Daisy chaining*), at bus level, is another connection topology commonly used in traditional, industrial automation system networks. The cable segments link several peripherals to each other, constituting the peripheral "section" of the network cable.

Ethernet Power extension (Daisy chain)

Power extension is not yet a very commonly used Ethernet connection topology, but will quickly become so when a large number of peripherals are made available in the market.

In an Ethernet power extension topology, the peripherals have:

- 2 Ethernet ports
- and an integrated switch.

Schneider Electric is progressively introducing, into the industrial market, Ethernet peripherals that can be used in daisy chain type architectures.

Implementation of a power extension topology

No hub or switch is required for using a power extension topology. Each peripheral must have an integrated switch (two ports).

A port on the peripheral is connected to a port on the neighbouring upstream and downstream peripherals. These consecutive connections constitute the power extension (daisy chain).

Ethernet switches may be included in a power extension (daisy chain) topology when several scan chains are used by the monitoring peripheral.

The Ethernet switch must be installed close to the monitoring peripheral, with the various scan chains coming from the switch.

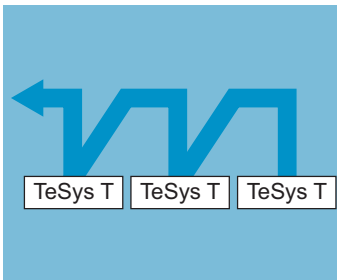

Daisy chain topology

(1) FDR: Faulty Device Replacement.

(2) SNMP: Simple Network Management Protocol.

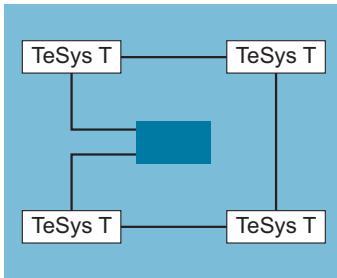

Ring topology

Ethernet: different network topologies (continued)

Ring topology

In a ring topology, all the peripherals or components of the network infrastructure are connected within a loop.

This type of topology makes it possible to achieve different levels of redundancy of the network.

Ethernet ring

Ethernet rings are generally the main networks in applications where a high level of reliability is required. If a ring topology is required, the switches handling this function must be used.

Redundancy

Redundancy of the network infrastructure is the key to development of applications with high operational reliability.

Implementing a single or double ring architecture makes it possible to provide protection against breaks in network segments.

Single ring

The first level of redundancy can be achieved by installing a single ring.

ConneXium switches can be used to establish main network ring configurations.

The ring is created using HIPER-Ring ports.

If a section of the line fails, the ring structure (including a maximum of 50 switches) converts into a line type configuration in less than 0.5 seconds.

Possible configurations and applications

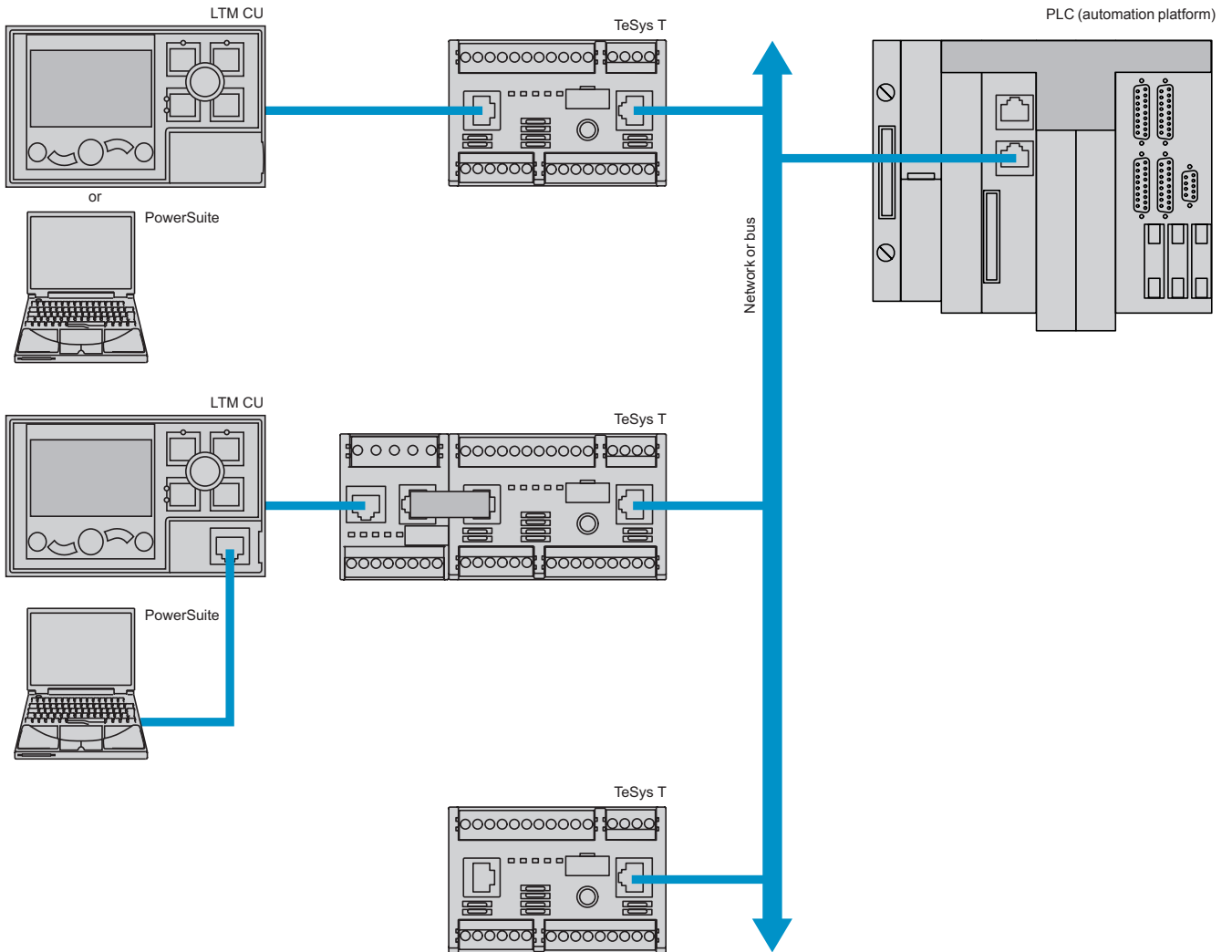

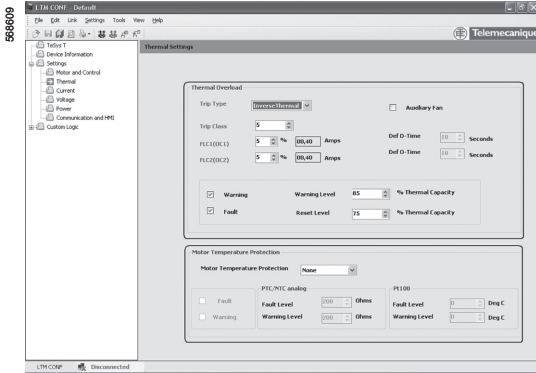

Example of TeSys T configurator setup screen

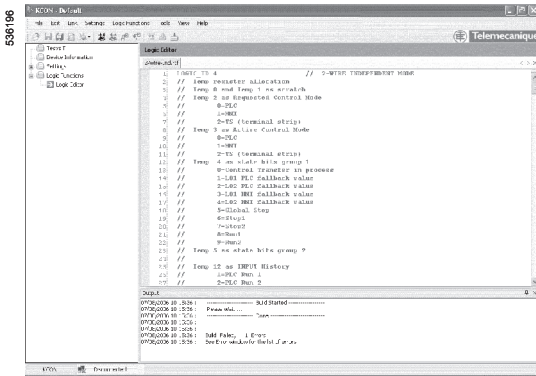

Example of logic editor screen.

Configuration with PowerSuite

The TeSys T configurator is incorporated in the PowerSuite software application, as from version 2.5. (1)
It allows configuration, commissioning and maintenance of motor starters protected by TeSys T.

A library containing predefined motor control mode functions is available in order to:

- allow standardisation,
- avoid errors,
- reduce motor starter setup times.

5 predefined motor control modes are incorporated in the controller:

- overload mode: monitoring of motors whose control is not managed by the controller,
- independent mode: starting of non-reversing motors,
- reverser mode: starting of reversing motors,
- 2-step mode: 2-step starting of motors (star-delta, by autotransformer and by resistor),
- 2-speed mode: 2-speed starting of motors (Dahlander, pole changer).

By using logic functions, a "Custom" mode makes it possible to:

- easily adapt these predefined motor control mode functions to the specific needs of your applications,
- create a link with the motor starter environment or
- create new functions.

The functions thus defined can be saved and used to build your function library for future applications.
To create special functions, a logic editor is incorporated in the configurator and allows a choice of 2 programming languages:

- function block,
- structured text.

(1) An update file is available, free of charge, on the website "www.schneider-electric.com". It will enable you to take advantage of the latest functions in the TeSys T motor management system.

Environment		LTM R controllers		LTM EV40 extension modules			
Product type		LTM R controllers		LTM EV40 extension modules			
Conforming to standards		IEC/EN 60947-4-1, UL 508, CSA 22-2 n°14, IACS E10					
Product certifications		UL, CSA, BV, LROS, DNV, GL, RINA, ABS, RMRos, NOM, CCC, C-TIC'K, ATEX, GOST, KERI (1)					
Rated insulation voltage of the outputs (Ui)	Conforming to IEC/EN 60947-1, overvoltage category III, degree of pollution 3	V	690				
	Conforming to UL 508, CSA C222 n° 14	V	690				
Rated impulse withstand voltage (Uimp)	Conforming to IEC/EN 60947-4-1						
	~ 100...240 V supply, inputs and outputs	kV	4	4			
	--- 24 V supply, inputs and outputs	kV	0.8	0.8			
	Communication circuits	kV	0.8	-			
	Current or voltage measurement circuit	kV	6	6			
Short-circuit withstand	Conforming to IEC/EN 60947-4-1	kA	100				
Protective treatment	Conforming to IEC/EN 60068		"TH"				
	Conforming to IEC/EN 60068-2-30		12 x 24 hour cycles				
	Conforming to IEC/EN 60070-2-11	h	48				
Ambient air temperature around the device	Storage	°C	- 40...+80				
	Operation	°C	- 20...+60				
Operating position without dating	In relation to normal vertical mounting plane		± 30° in relation to mounting plate, ± 90°				
Flame resistance	Conforming to UL 94	°C	960 (for parts supporting live components)				
	Conforming to IEC/EN 60695-2-12	°C	650 (for other parts)				
Shock resistance (1/2 sine wave, 11 ms)	Conforming to IEC/EN 60068-2-27 (2)		15 gn				
Vibration resistance	Conforming to IEC/EN 60068-2-6 (2)		4 gn (plate mounted)				
	5...300 Hz		1 gn (mounted on rail)				
Resistance to electrostatic discharge	Conforming to IEC/EN 61000-4-2	kV	In open air: 8 - Level 3 On contact: 6 - Level 3				
Immunity to radiated electromagnetic interference	Conforming to IEC 61000-4-3	V/m	10 - Level 3				
Immunity to fast transient bursts	Conforming to IEC 61000-4-4	kV	On supply and relay outputs: 4 - Level 4 Other circuits: 2 - Level 3				
Immunity to radioelectric fields	Conforming to IEC/EN 61000-4-6	V	10 - Level 3				
Immunity to dissipated shock waves	Conforming to IEC/EN 61000-4-5		Common mode	Serial mode	Common mode	Serial mode	
	Relay outputs and supply	kV	4	2	-	-	
	--- 24 V inputs	kV	1	1	1	1	
	~ 100...240 V inputs	kV	2	1	2	1	
	Voltage inputs	kV	-	-	4	2	
	Communication	kV	2	-	2	-	
	Temperature sensor (IT1/IT2)	kV	1	0.5	-	-	
Altitude derating			2000 m	3000 m	3500 m	4000 m	4500 m
	Rated operational voltage (Ui)		1	0.93	0.87	0.8	0.7
	Max. operating temperature		1	0.93	0.92	0.9	0.88

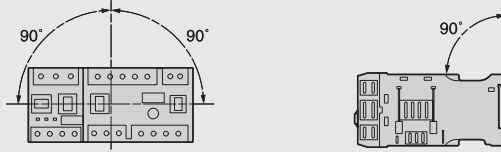

(1) Certain certifications are pending: please consult your Customer Care Centre.
1) Without modifying the contact states, in the most unfavourable direction.

Controller and extension module characteristics							
Product type		Controllers			Extension modules		
		LTM R●●●BD	LTM R●●●FM	LTM EV40BD	LTM EV40FM		
Control supply							
Operational voltage (U)	Conforming to IEC/EN 60947-1	V	--- 24	~ 100...240	-		
Resistance to voltage dips	Conforming to IEC/EN 61000-4-11	V	0 for 3 ms 70% of U for 500 ms		-		
Associated protection		A	gG fuse, 0.5		-		
Operational voltage		V	--- 20.4...26.24	~ 93.5...264	-		
Current consumption	50/60 Hz	mA	--- 56...127	~ 8...62.8	-		
Cabling							
Connectors	Pitch	mm	5.08		5.08		
Flexible cable without cable end	1 conductor	mm ²	0.2...2.5		0.2...2.5		
	2 identical conductors	mm ²	0.2...1.5		0.2...1.5		
Flexible cable with cable end	Without insulated ferrule	1 conductor	0.25...2.5		0.25...2.5		
		2 identical conductors	0.5...1.5		0.5...1.5		
	With insulated ferrule	1 conductor	0.25...2.5		0.25...2.5		
		2 identical conductors	0.2...1		0.2...1		
Solid cable without cable end	1 conductor	mm ²	0.2...2.5		0.2...2.5		
	2 identical conductors	mm ²	0.2...1		0.2...1		
Conductor size			AWG 24 to AWG 14		AWG 24 to AWG 14		
Tightening torque		N.m	0.5...0.6		0.5...0.6		
Flat screwdriver		mm	3		3		
Input characteristics							
Nominal values	Conforming to IEC/EN 61131-1		Type 1 positive logic (---: resistive, ~: capacitive)				
Voltage		V	--- 24	~ 100...240	--- 24	~ 100...240	
Current		mA	--- 7	~ 3.1 for 100 V ~ 7.5 for 240 V	--- 7	~ 3.1 for 100 V ~ 7.5 for 240 V	
Logic inputs	Logic state 1	Voltage	V	15 max	79 < U < 264	15 max	79 < U < 264
		Current	mA	2 min...15 max	2 min at 110 V... 3 min at 220 V	2 min...15 max	2 min at 110 V... 3 min at 220 V
	Logic state 0	Voltage	V	5 max	0 < U < 40	5 max	0 < U < 40
		Current	mA	15 max	15 max	15 max	15 max
Response time	Change to state 1	ms	15	25	15	25	
	Change to state 0	ms	5	25	5	25	
Output characteristics							
Type			Volt free, single break				
Load	~		250 V / 5 A B300				
	---		30 V / 5 A				
Permissible power in cat. AC-15	For 500 000 operating cycles	VA	480 / I _e max: 2 A				
Permissible power in cat. DC-13	For 500 000 operating cycles	W	30 / I _e max: 1.25 A				
Associated protection		A	gG fuse, 4				
Max. frequency		Hz	2				
Max. operating level		op. cycles/h	1800				
Response time	Change to state 1	ms	10 max				
	Change to state 0	ms	10 max				
Measurement details							
Current			1 % for the 0.4...8 A and 1.35...27 A ranges 2 % for the 5...100 A range				
Voltage			1% from 100 to 830 V				
Earth fault current	Internal measurement without earth fault toroid		5...15 % for current > 0.1 A in the 0.4...8 A range current > 0.2 A in the 1.35...27 A range current > 0.3 A in the 5...100 A range				
	External measurement with earth fault toroid		< 5 % or 0.01 A				
Temperature measurement			2 %				
Power factor			3 % for a Cos φ > 0.6				
Active and reactive power			5 % (typical value)				
Internal clock			± 30 min / year				

Bus and network characteristics						
Type of bus/network		Modbus	CANopen	DeviceNet	Profibus DP	Ethernet
Physical interface		2-wire RS 485	ISO 11898	ISO 11898	polarised 2-wire RS 485	IEEE 802.3
Addressing		1 to 247	1 to 127	1 to 64	1 to 125	0 to 159
Transmission speeds		1.2 to 19.2 K bits/s	10, 20, 50, 125, 250, 500, 800 and 1000 K bits/s + Auto baud	125 to 500 K bits/s	9.6 K to 12 M bits/s	10/100 Mbit/s, with automatic recognition
Connections		RJ45/terminal block	9-way SUB-D/terminal block	Terminal block	9-way SUB-D/terminal block	RJ45
Cables		2 shielded twisted pairs	4 twisted, shielded wires	4 twisted, shielded wires	2 shielded twisted pairs, type A	2 shielded twisted pairs

LTM CU operator control unit			
Environment			
Conforming to standards			IEC/EN 61131-2, UL 508, CSA 22-2 n°14
Product certifications			UL, CSA, CE, C-TIC'K, NOM, GOST
Ambient air temperature around the device	Storage	°C	-40...+80
	Operation	°C	-20...+60
Relative humidity			15...95 % without condensation
Protective treatment	Conforming to IEC/EN 60068-2-30		12 x 24 hour cycles
Degree of protection	Conforming to IEC 60947-1		IP 54
Shock resistance	Conforming to IEC/EN 60068-2-27		15 gn / 11ms
Vibration resistance	Conforming to IEC/EN 60068-2-6 5...30 Hz		4 gn
Flame resistance	Conforming to IEC 60947-1	°C	650
	Conforming to UL 94		V2

Electrical characteristics			
Supply to the product			Powered via the controller
Maximum current		mA	140
Maximum power dissipated		W	1
Resistance to electromagnetic discharge	Conforming to IEC/EN 61000-4-2	kV	In open air: 8. Level 3 On contact: 4. Level 3
Immunity to radiated electromagnetic interference	Conforming to IEC/EN 61000-4-3	V/m	10 - Level 3
Immunity to fast transient bursts	Conforming to IEC/EN 61000-4-4	kV	2, shielded access. Level 3
Immunity to radioelectric fields	Conforming to IEC/EN 61000-4-6	V	10. Level 3
Immunity to shock waves	Conforming to IEC/EN 61000-4-5	kV	2, shielded access. Level 3

Physical characteristics		
Mounting		Flush mounted
Display		Backlit LCD
Signalling		By 4 LEDs
Cabling		RJ45

LT6 CT●●●● external current transformer characteristics

Conforming to standards	IEC 60185, BS 7626				
Precision	Class 5P				
Precision limit factor	15				
Rated insulation voltage (Ui)	690				
Maximum operating temperature	°C	50			
Transformer ratio	A	100/1	200/1	400/1	800/1
Diameter of conductor passage hole	mm	35	35	35	35
Maximum cabling c.s.a.	mm ²	30 x 10	30 x 10	30 x 10	incorporated (1)

Earth fault toroid characteristics

Toroid type	50437 50438 50439 50440 50441 50442 50485 50486								
Rated insulation voltage Ui	V	1000							
Operating temperature	°C	- 35... + 70							
Protection index	IP30 (connections IP20)								
Transformer ratio	1/1000								
Rated operational current Ie	A	65	85	160	250	400	630	85	250
Max. conductor c.s.a. per phase	mm ²	25	50	95	240	2 x 185	2 x 240	50	240

DA1 TT●● probe characteristics

Conforming to standards	IEC 60034-11 mark A	
Economy resistor	At 25 °C	Ω 3 x 250 in series
Rated operational voltage (Ue)	Per probe	V --- 2.5 max
Rated insulation voltage (Ui)		kV 2.5
Insulation		Reinforced
Length of connecting cables	Between probes	mm 250
	Between probe and motor terminal plate	m 1

Guaranteed operating zones: example with 3 probes type DA1 TT●●● (250 Ω at 25 °C) in series, conforming to standard EC 60034-11, mark A.

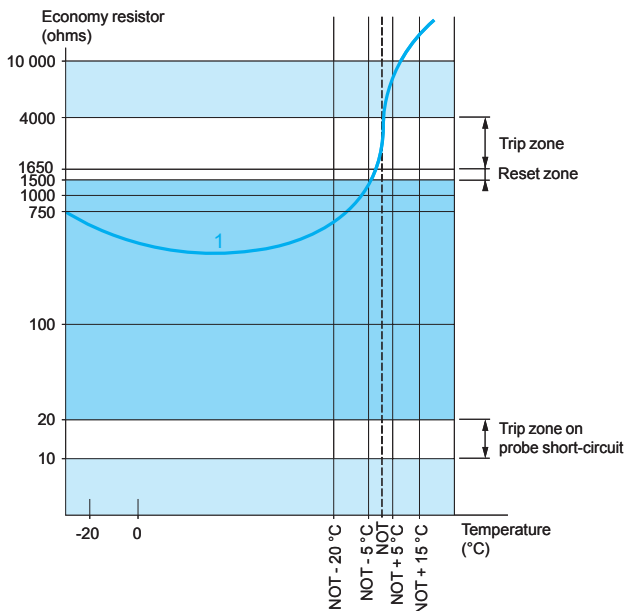

1 3 probes type DA1●●● (250 Ω at 25 °C) in series.

NOT: Nominal Operating Temperature.

Protection unit tripped.

Protection unit reset.

(1) Electrical connection to be made using M10 bolt.

Cold state curves

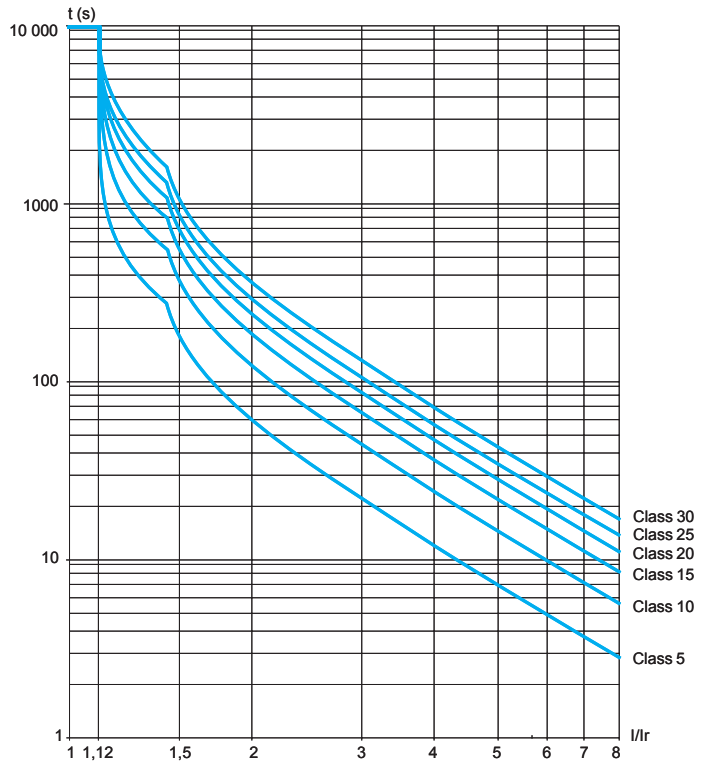

Hot state curves

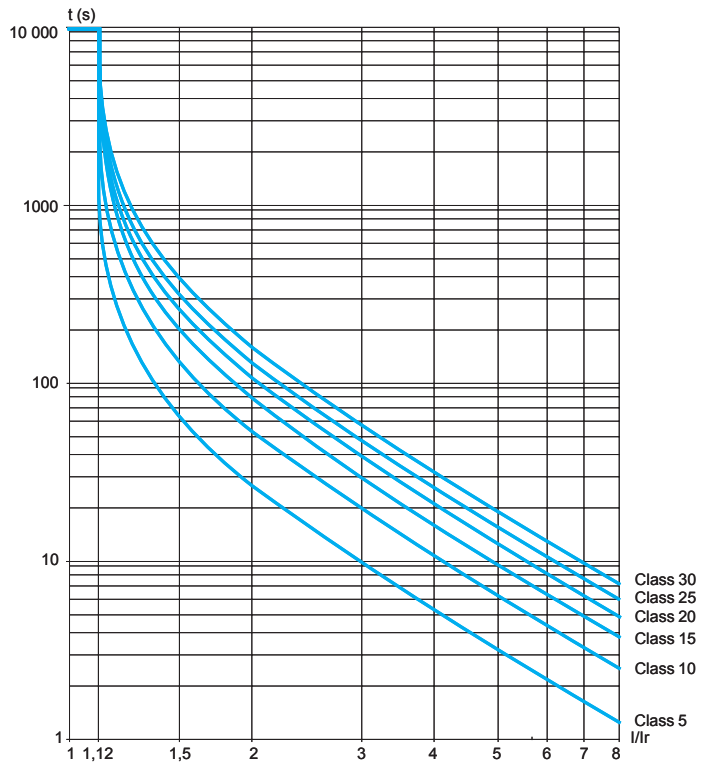

526387

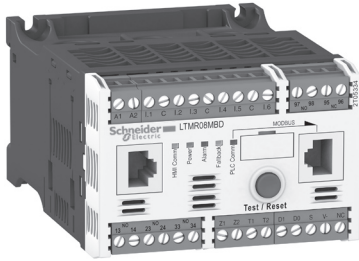

LTM R08MBD

526388

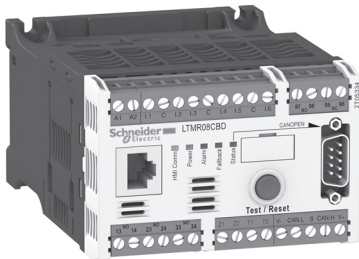

LTM R08CBD

526389

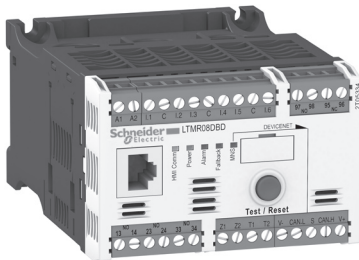

LTM R08DBD

526390

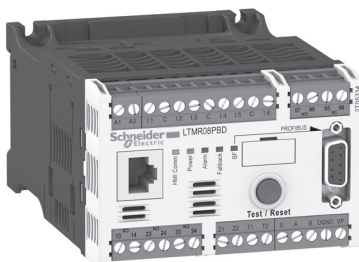

LTM R08PBD

526391

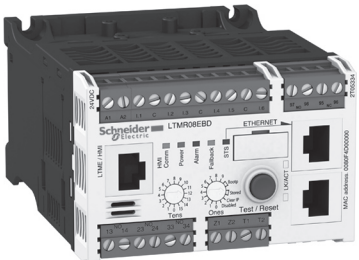

LTM R08EBD

Controllers				
Setting range	Control voltage	Current range	Reference	Weight
A	V	A		kg
For Modbus				
8	— 24	0.4...8	LTM R08MBD	0.530
	~ 100...240 V	0.4...8	LTM R08MFM	0.530
27	— 24	1.35...27	LTM R27MBD	0.530
	~ 100...240 V	1.35...27	LTM R27MFM	0.530
100	— 24	5...100	LTM R100MBD	0.530
	~ 100...240 V	5...100	LTM R100MFM	0.530
For CANopen				
8	— 24	0.4...8	LTM R08CBD	0.530
	~ 100...240 V	0.4...8	LTM R08CFM	0.530
27	— 24	1.35...27	LTM R27CBD	0.530
	~ 100...240 V	1.35...27	LTM R27CFM	0.530
100	— 24	5...100	LTM R100CBD	0.530
	~ 100...240 V	5...100	LTM R100CFM	0.530
For DeviceNet				
8	— 24	0.4...8	LTM R08DBD	0.530
	~ 100...240 V	0.4...8	LTM R08DFM	0.530
27	— 24	1.35...27	LTM R27DBD	0.530
	~ 100...240 V	1.35...27	LTM R27DFM	0.530
100	— 24	5...100	LTM R100DBD	0.530
	~ 100...240 V	5...100	LTM R100DFM	0.530
For Profibus DP				
8	— 24	0.4...8	LTM R08PBD	0.530
	~ 100...240 V	0.4...8	LTM R08PFM	0.530
27	— 24	1.35...27	LTM R27PBD	0.530
	~ 100...240 V	1.35...27	LTM R27PFM	0.530
100	— 24	5...100	LTM R100PBD	0.530
	~ 100...240 V	5...100	LTM R100PFM	0.530
For Ethernet TCP/IP				
8	— 24	0.4...8	LTM R08EBD	0.530
	~ 100...240 V	0.4...8	LTM R08EFM	0.530
27	— 24	1.35...27	LTM R27EBD	0.530
	~ 100...240 V	1.35...27	LTM R27EFM	0.530
100	— 24	5...100	LTM R100EBD	0.530
	~ 100...240 V	5...100	LTM R100EFM	0.530

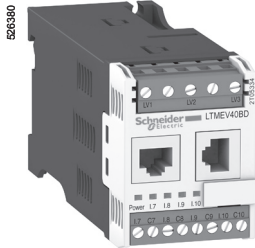

LTM EV40BD



LTM CU

Extension modules. with voltage measurement on the 3 phases

Input control voltage	Number of inputs	Supply to the electronics	Reference	Weight
				V
⎓ 24	4	Via the controller	LTM EV40BD	0.210
~ 100...240	4	Via the controller	LTM EV40FM	0.210

HMI terminals

Description	Supply Voltage	Reference	Weight
Operator control unit	Supply via the controller	LTM CU	0.400
Magelis compact display.	⎓ 24 V external	XBT N410	0.380

Description	Number and type of connectors	Length m	Reference	Weight kg
Connecting cables for the LTM CU control unit	2 x RJ45	1	VW3 A1 104R10	0.065
		3	VW3 A1 104R30	0.140
		5	VW3 A1 104R50	0.210
Connecting cables for the XBT N410	SUB-D 25-way female RJ45	2.5	XBT Z938	0.200

Cables

Description	Number and type of connectors	Length m	Reference	Weight kg
Connecting cables For connecting the controller to the extension module	2 x RJ45	0.04	LTM CC004 (1)	0.120
		0.3	LU9 R03	0.045
		1	LU9 R10	0.065

Replacement connectors

Description	Number and type of connectors	Reference	Weight kg
Complete set of connectors for controllers and extension modules	10 screw terminals (all network versions included)	LTM 9TCS	0.200

(1) Sold in lots of 6.

Configuration tools			
Description	Composition	Reference	Weight kg
Connection kit for PC serial port for Modbus multidrop connection	<ul style="list-style-type: none"> 1 x 3 m length cable with two RJ45 connectors, 1 RS 232/RS 485 converter with one 9-way female SUB-D connector and one RJ45 connector. 	VW3 A8 106	–
Interface for USB port (for use with cable VW3 A8 106) Length: 1.8 m	<ul style="list-style-type: none"> 1 USB cable, SUB-D 9-way Drivers supplied on CD-Rom 	SR2 CBL06	0.350

Current transformers (1)			
Operational current		Reference	Weight
Primary	Secondary		kg
A	A		
100	1 (2)	LT6 CT1001	0.550
200	1 (2)	LT6 CT2001	0.550
400	1 (2)	LT6 CT4001	0.550
800	1 (2)	LT6 CT8001	0.680

Earth fault toroids (marketed under the Schneider Electric brand)			
Rated operational current Ie	Internal Ø of toroid	Reference	Weight
A	mm		kg
Closed toroids, type A			
65	30	50437	0.120
85	50	50438	0.200
160	80	50439	0.420
250	120	50440	0.530
400	200	50441	1.320
630	300	50442	2.230

Split toroids, type OA			
85	46	50485	1.300
250	110	50486	3.200

PTC thermistor probes (3)				
Description	Nominal Operating Temperature (NOT)	Colour	Unit reference (4)	Weight
	°C			kg
Triple probes	90	Green/green	DA1 TT090	0.010
	110	Brown/brown	DA1 TT110	0.010
	120	Grey/grey	DA1 TT120	0.010
	130	Blue/blue	DA1 TT130	0.010
	140	White/blue	DA1 TT140	0.010
	150	Black/black	DA1 TT150	0.010
	160	Blue/red	DA1 TT160	0.010
	170	White/green	DA1 TT170	0.010

(1) The transformers offered for use with TeSys U starters are suitable. Please consult our "TeSys U starter-controllers" catalogue.

(2) For use with LTM R08●● controllers.

(3) PTC: Positive Temperature Coefficient.

(4) Sold in lots of 10.



LT6 CT4001



DA1 TT●●●

Protection components

TeSys T Motor Management System

Marking accessories (to be ordered separately)

Description	Composition	Sold in lots of	Unit reference	Weight kg
Clip-in markers (maximum of 5 per unit)	Strips of 10 identical numbers (0 to 9)	25	AB1 R● (1)	0.002
	Strips of 10 identical capital letters (A to Z)	25	AB1 G● (1)	0.002

Connection accessories

Description	Length m	Reference	Weight kg
For Modbus connection			
Cables fitted with 2 x RJ45 connectors	0.3	VW3 A8 306 R03	0.045
	1	VW3 A8 306 R10	0.065
	3	VW3 A8 306 R30	0.125
T-junctions	0.3	VW3 A8 306 TF03	0.032
	1	VW3 A8 306 TF10	0.032
RS 485 line terminator	–	VW3 A8 306 R	0.012

For CANopen connection

Cables	50	TSX CAN CA50	4.930	
	100	TSX CAN CA100	8.800	
	300	TSX CAN CA300	24.560	
IP20 connectors SUB-D 9-way female Line end adapter switch	Elbowed (90°)	–	TSX CAN KCDF 90T	0.046
	Straight	–	TSX CAN KCDF 180T	0.049
	Elbowed (90°) with SUB-D 9-way connector for connection to PC or diagnostic tool	–	TSX CAN KCDF 90TP	0.051

For DeviceNet connection

Cables	50	TSX CAN CA50	4.930
	100	TSX CAN CA100	8.800
	300	TSX CAN CA300	24.560

For Profibus DP connection (2)

Cables	100	TSX PBSCA100	–	
	400	TSX PBSCA400	–	
Connectors	With line terminator	–	490 NAD 911 03	–
	Without line terminator	–	490 NAD 911 04	–
	With line terminator and terminal port	–	490 NAD 911 05	–

For Ethernet TCP/IP connection

Shielded twisted pair cables to standard EIA/TIA568				
Cables fitted with 2 x RJ45 connectors for connection to terminal equipment	Straight	2	490 NTW 000 02	–
		5	490 NTW 000 05	–
		12	490 NTW 000 12	–
		40	490 NTW 000 40	–
		80	490 NTW 000 80	–
Shielded twisted pair cables, UL and CSA 22.1 approved				
Cables fitted with 2 x RJ45 connectors for connection to terminal equipment	Straight	2	490 NTW 000 02U	–
		5	490 NTW 000 05U	–
		12	490 NTW 000 12U	–
		40	490 NTW 000 40U	–
		80	490 NTW 000 80U	–

(1) When ordering, replace the ● in the reference with the number or letter required.

(2) To order other connectors and cables (UL cables for harsh environments, etc.), please consult your Customer Care Centre.

LTM R●● controllers

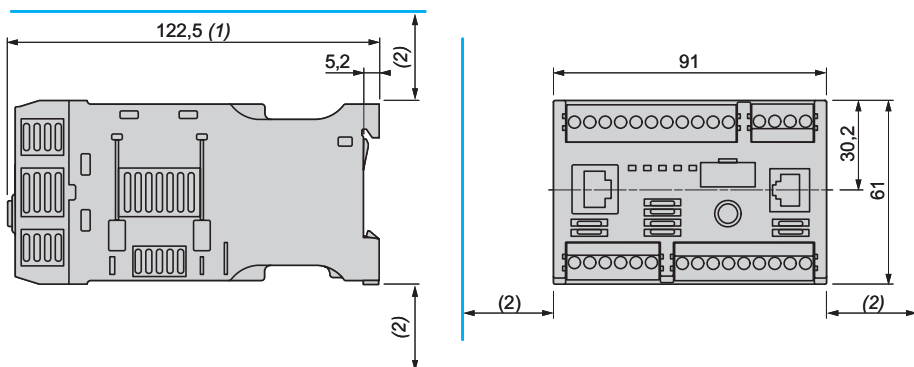

LTM EV40●● extension modules

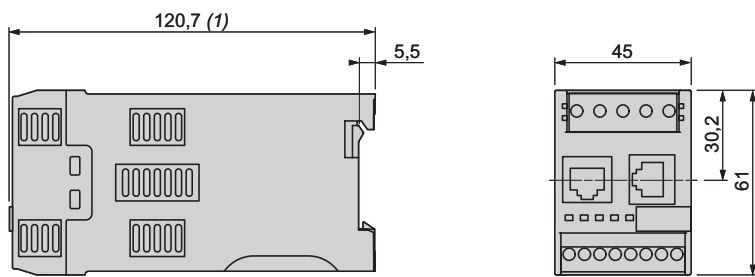

LTM CU operator control unit

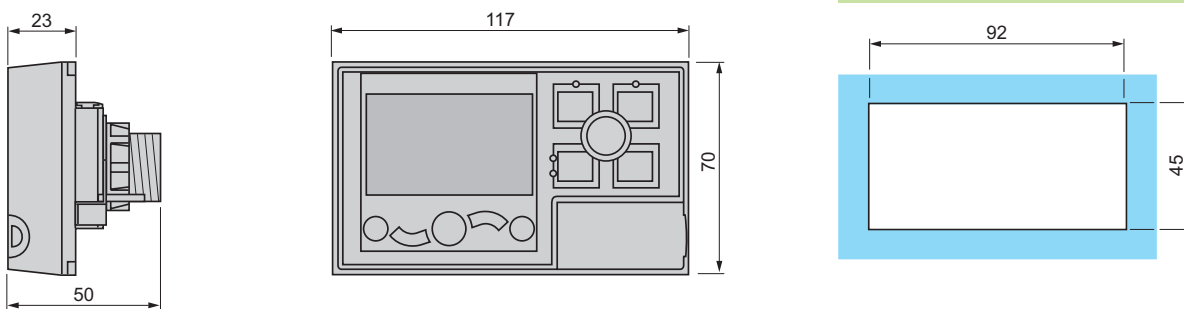

Panel mounting, cut-out

(1) 140 mm with RJ45 connector for connection to extension module and to network,
166 mm with Profibus DP/CANopen connector.
(2) Leave a gap around the device of: 9 mm at 45 °C, 9 to 40 mm from 45 to 50 °C, 40 mm at 60 °C.

Current transformers

LT6 CT

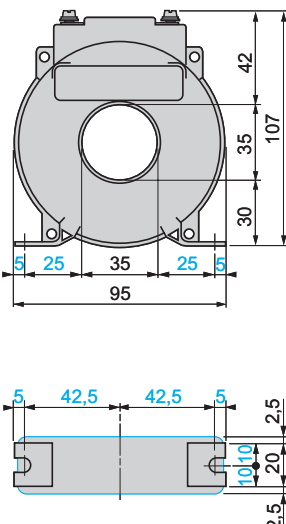

HMI terminal

XBT N410

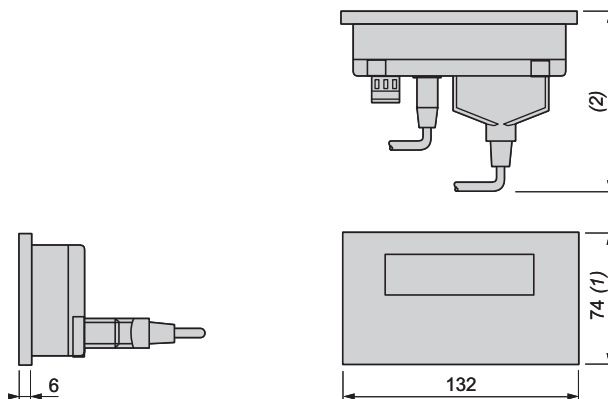

(1) 104 mm with fixing clips (supplied with the product).
 (2) 58 mm with SUB-D 25-way elbowed cable **XBT Z9680** for Twido, TSX Micro and Premium or **XBT Z998** for Advantys STB.
 104 mm with SUB-D 25-way cable **XBT Z68/Z9681** for Twido, TSX Micro and Premium

Earth fault toroids

50437 and 50438

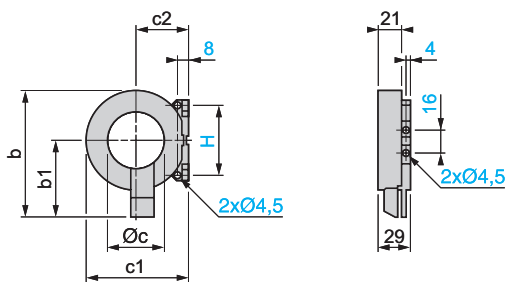

50439, 50440 and 50441

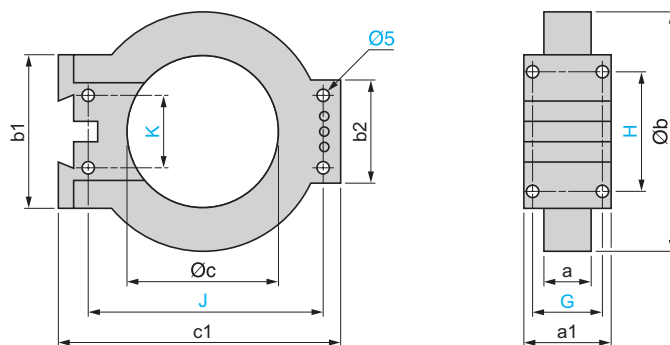

Type	b	b1	Øc	c1	c2	H
50437	83	53	30	60	31	50
50438	109	66	50	87	45	60

Type	a	a1	Øb	b1	b2	Øc	c1	G	H	J	K
50439	26.5	44	122	80	55	80	150	35	65	126	40
50440	26.5	44	164	80	55	120	190	35	65	166	40
50441	29	46	256	120	90	196	274	37	104	254	60

50442

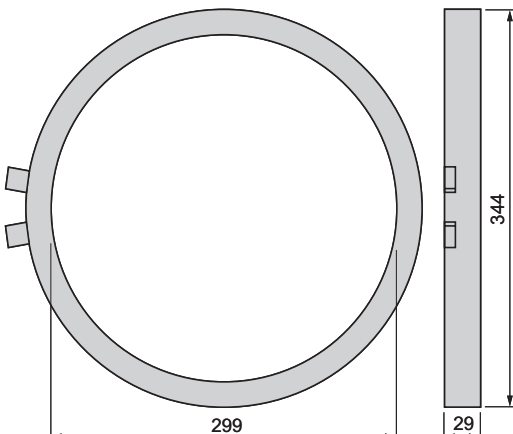

50485 and 50486

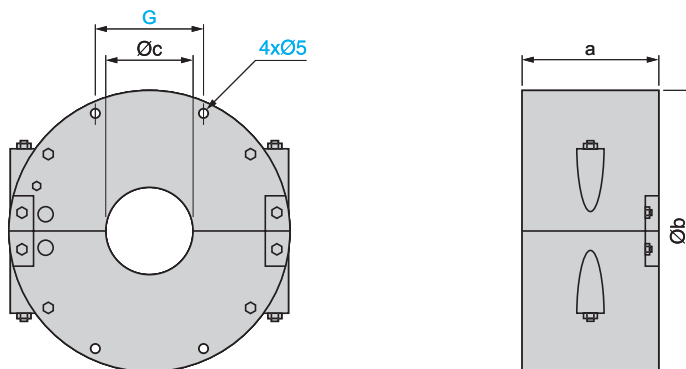

Type	a	Øb	Øc	G
50485	72	148	46	57
50486	78	224	110	76

Schemes

Overload mode

3-wire local-control

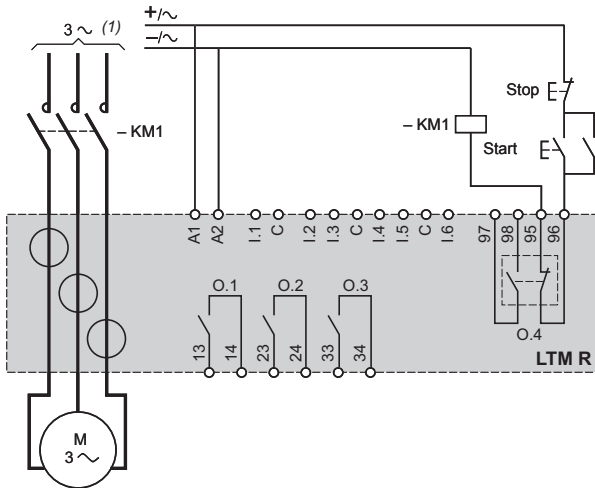

(1) Connection of a single-phase motor is possible. In this case, do not use the central current transformer.

Independent mode

3-wire local-control

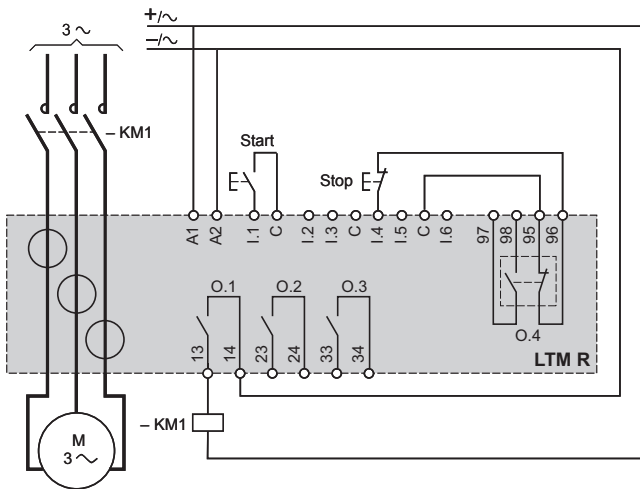

2-wire local-control

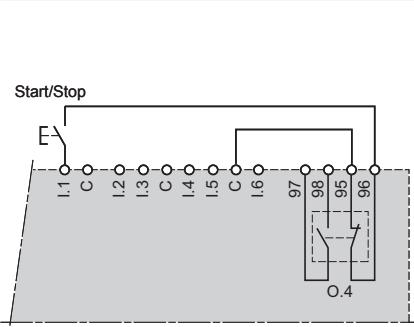

3-wire with switchable local/network control

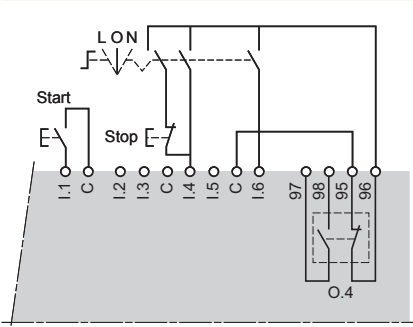

2-wire with switchable local/network control

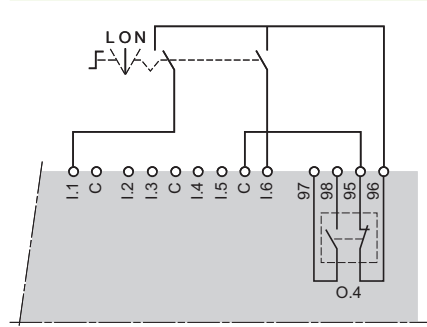

L : Local control
 O : Stop
 N : Network control

Schemes (continued)

Reverser mode
3-wire local-control

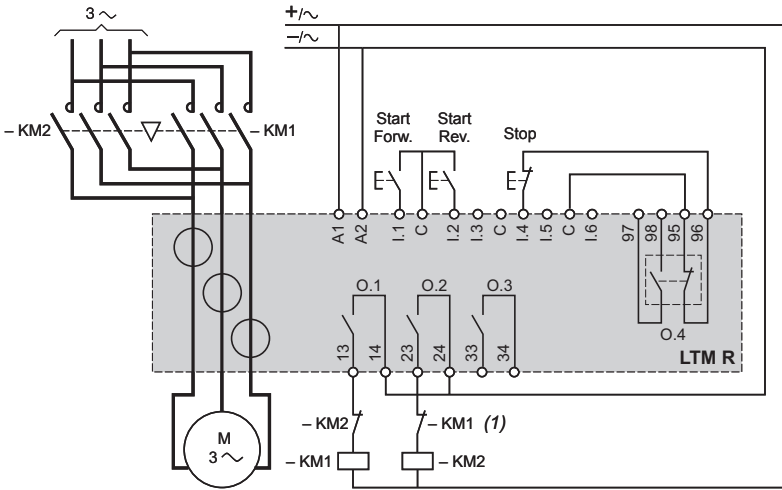

2-step mode, star-delta application
3-wire local-control

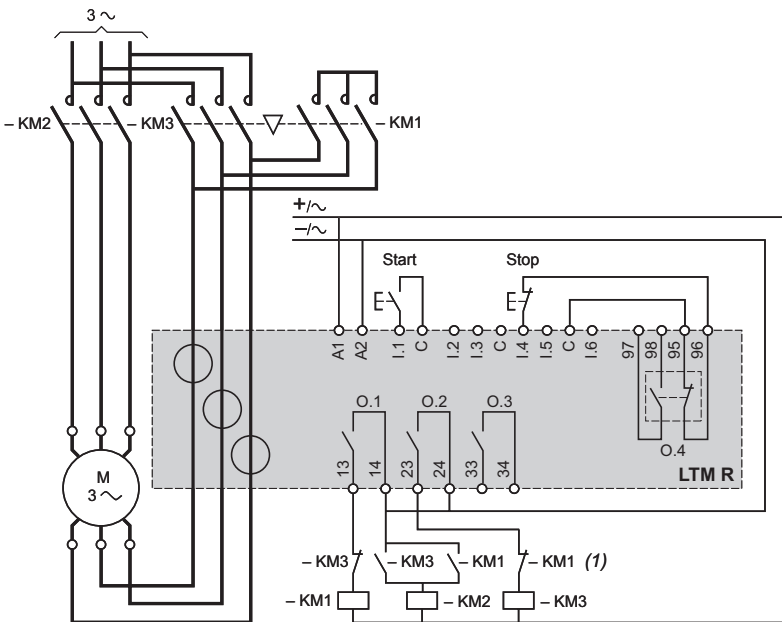

(1) Contacts for interlocking KM1 and KM2 are not obligatory because the controller electronically interlocks outputs O.1 and O.2.

Schemes (continued)

2-step mode, primary resistor application

3-wire local-control

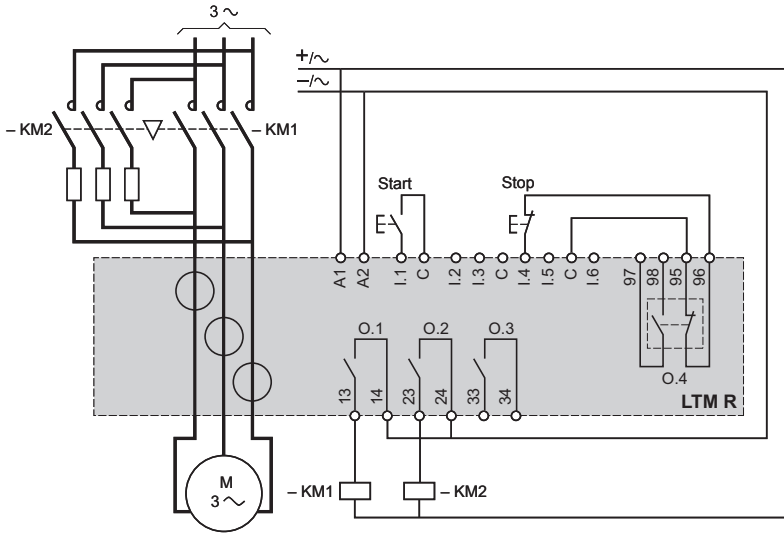

2-speed mode, Dahlander application

3-wire local-control

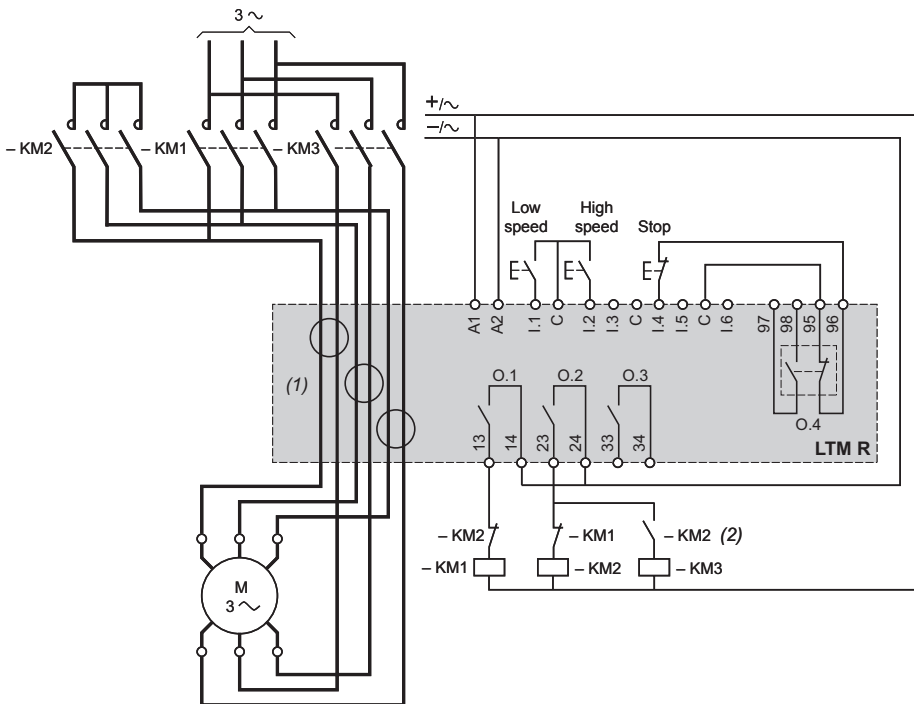

(1) For a Dahlander application, all the power cables must pass through current transformers. The controller can also be placed upstream of the contactor. In this case, and if the Dahlander motor is used in "variable torque" mode, all the cables downstream of the contactors must be of identical size.
 (2) Contacts for interlocking KM1 and KM2 are not obligatory because the controller electronically interlocks outputs O.1 and O.2.

Schemes (continued)

Earth fault toroid and motor temperature probe connection

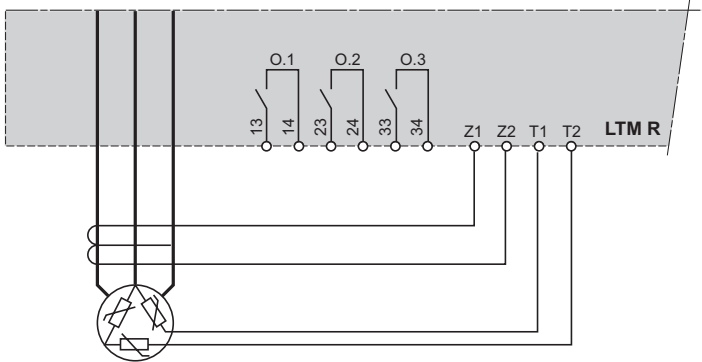

Connection of outputs for motor control mode function

Without intermediate relay

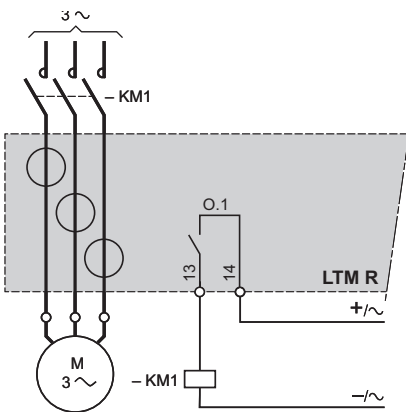

With intermediate relay

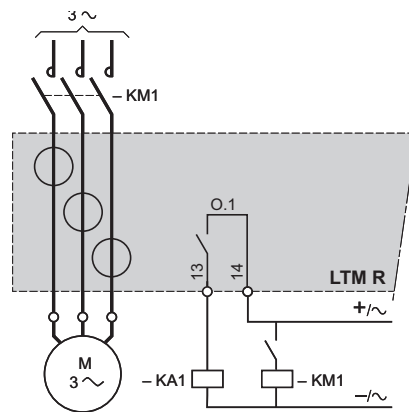

0.37 to 355 kW at 400/415 V: type 2 coordination							
With switch-disconnector, contactor and class 10 controller							
Standard power ratings of 3-phase motors 50/60 Hz in category AC-3 400/415 V		Switch-disconnector	aM fuses		Contactor	TeSys T controller	External current transformer
P	I _e	Reference (1)	Size	Rating	Reference (2)	Reference	Reference
kW	A			A			
0.37	1.1	GS1 DD	10 x 38	2	LC1 D09	LTM R08●●	–
0.55	1.5	GS1 DD	10 x 38	2	LC1 D09	LTM R08●●	–
0.75	1.9	GS1 DD	10 x 38	4	LC1 D09	LTM R08●●	–
1.1	2.7	GS1 DD	10 x 38	4	LC1 D09	LTM R08●●	–
1.5	3.6	GS1 DD	10 x 38	4	LC1 D09	LTM R08●●	–
2.2	4.9	GS1 DD	10 x 38	6	LC1 D09	LTM R08●●	–
3	6.5	GS1 DD	10 x 38	8	LC1 D09	LTM R27●●	–
4	8.5	GS1 DD	10 x 38	10	LC1 D09	LTM R27●●	–
5.5	11.5	GS1 DD	10 x 38	16	LC1 D12	LTM R27●●	–
7.5	15.5	GS1 DD	10 x 38	16	LC1 D25	LTM R27●●	–
10	19	GS● F	14 x 51	25	LC1 D25	LTM R27●●	–
11	22	GS● F	14 x 51	25	LC1 D25	LTM R27●●	–
15	29	GS● F	14 x 51	32	LC1 D32	LTM R100●●	–
18.5	35	GS● F	14 x 51	40	LC1 D40A	LTM R100●●	–
22	41	GS● J	22 x 58	50	LC1 D50A	LTM R100●●	–
30	55	GS● J	22 x 58	80	LC1 D65A	LTM R100●●	–
37	66	GS● J	22 x 58	100	LC1 D80	LTM R100●●	–
45	80	GS● J	22 x 58	100	LC1 D95	LTM R100●●	–
55	97	GS● K	T00	125	LC1 D115	LTM R08●●	LT6 CT2001
75	132	GS● L	T0	160	LC1 D150	LTM R08●●	LT6 CT2001
90	160	GS● N	T1	200	LC1 F185	LTM R08●●	LT6 CT2001
110	195	GS● N	T1	250	LC1 F225	LTM R08●●	LT6 CT4001
132	230	GS● QQ	T2	315	LC1 F265	LTM R08●●	LT6 CT4001
160	280	GS● QQ	T2	355	LC1 F400	LTM R08●●	LT6 CT4001
200	350	GS2 S	T3	500	LC1 F400	LTM R08●●	LT6 CT8001
250	430	GS2 S	T3	500	LC1 F500	LTM R08●●	LT6 CT8001
315	540	GS2 S	T3	630	LC1 F630	LTM R08●●	LT6 CT8001
355	610	GS2 V	T4	800	LC1 F630	LTM R08●●	LT6 CT8001

(1) GS●: GS1 for direct operator, GS2 for external operator.

(2) For reversing operation, replace the prefix LC1 with LC2.

0.06 to 250 kW at 400/415 V: type 2 coordination						
With circuit-breaker, contactor and class 10 controller						
Standard power ratings of 3-phase motors 50/60 Hz in category AC-3 400/415 V			Circuit-breaker	Contactor	TeSys T controller	External current transformer
P	I _e	I _{cc}	Reference	Reference	Reference	Reference
kW	A	kA				
0.06	0.2	130	GV2 L03	LC1 D09	LTM R08●●	–
0.09	0.3	130	GV2 L03	LC1 D09	LTM R08●●	–
0.12	0.44	130	GV2 L04	LC1 D09	LTM R08●●	–
0.18	0.6	130	GV2 L04	LC1 D09	LTM R08●●	–
0.25	0.85	130	GV2 L05	LC1 D09	LTM R08●●	–
0.37	1.1	130	GV2 L05	LC1 D09	LTM R08●●	–
0.55	1.5	130	GV2 L06	LC1 D09	LTM R08●●	–
0.75	1.9	130	GV2 L07	LC1 D09	LTM R08●●	–
1.1	2.7	130	GV2 L07	LC1 D18	LTM R08●●	–
1.5	3.6	130	GV2 L08	LC1 D18	LTM R08●●	–
2.2	4.9	130	GV2 L10	LC1 D18	LTM R08●●	–
3	6.5	130	GV2 L14	LC1 D18	LTM R08●●	–
4	8.5	130	GV2 L14	LC1 D18	LTM R27●●	–
5.5	11.5	130	GV2 L16	LC1 D25	LTM R27●●	–
7.5	15.5	50	GV2 L20	LC1 D25	LTM R27●●	–
9	18.1	50	GV2 L22	LC1 D25	LTM R27●●	–
11	22	50	GV2 L22	LC1 D25	LTM R27●●	–
15	29	50	GV3 L32	LC1 D40A	LTM R100●●	–
18.5	35	50	GV3 L40	LC1 D50A	LTM R100●●	–
22	41	50	GV3 L50	LC1 D50A	LTM R100●●	–
30	55	50	GV3 L65	LC1 D65A	LTM R100●●	–
37	66	70	NS80HMA	LC1 D80	LTM R100●●	–
45	80	25	NS100HMA	LC1 D115	LTM R100●●	–
45	80	70	NS100HMA	LC1 D115	LTM R100●●	–

0.06 to 250 kW at 400/415 V: type 2 coordination (continued)

With circuit-breaker, contactor and class 10 controller

Standard power ratings of 3-phase motors 50/60 Hz
in category AC-3
400/415 V

Standard power ratings of 3-phase motors 50/60 Hz in category AC-3 400/415 V			Circuit-breaker	Contactor	TeSys T controller	External current transformer
P	I _e	I _{cc}	Reference	Reference	Reference	Reference
kW	A	kA				
55	97	36	NS160NMA	LC1 D115	LTM R08●●	LT6 CT2001
55	97	70	NS160HMA	LC1 D115	LTM R08●●	LT6 CT2001
75	132	36	NS160NMA	LC1 D150	LTM R08●●	LT6 CT2001
75	132	70	NS160HMA	LC1 D150	LTM R08●●	LT6 CT2001
90	160	36	NS250NMA	LC1 F185	LTM R08●●	LT6 CT2001
90	160	70	NS250HMA	LC1 F185	LTM R08●●	LT6 CT2001
110	195	36	NS250NMA	LC1 F225	LTM R08●●	LT6 CT2001
110	195	70	NS250HMA	LC1 F225	LTM R08●●	LT6 CT2001
132	230	70	NS400HMA	LC1 F265	LTM R08●●	LT6 CT4001
132	230	130	NS400LMA	LC1 F265	LTM R08●●	LT6 CT4001
160	280	70	NS400HMA	LC1 F330	LTM R08●●	LT6 CT4001
160	280	130	NS400LMA	LC1 F330	LTM R08●●	LT6 CT4001
200	350	70	NS630HMA	LC1 F400	LTM R08●●	LT6 CT4001
200	350	130	NS630LMA	LC1 F400	LTM R08●●	LT6 CT4001
220	388	70	NS630HMA	LC1 F500	LTM R08●●	LT6 CT4001
220	388	130	NS630LMA	LC1 F500	LTM R08●●	LT6 CT4001
250	430	70	NS630HMA	LC1 F500	LTM R08●●	LT6 CT6001
250	430	130	NS630LMA	LC1 F500	LTM R08●●	LT6 CT6001

Substitution table

Motor current	Old range LT6 P multifunction protection relay			New range TeSys T controllers		
	Reference	Reference	External current transformer Reference	Reference	Reference	External current transformer Reference
	~ 100...240 V	≡ 24 V		~ 100...240 V	≡ 24 V	
I < 5 A	LT6 P0M005FM	LT6 P0M005S144	–	LTM R08●FM	LTM R08●BD	–
5 A < I < 25 A	LT6 P0M025FM	LT6 P0M025S144	–	LTM R27●FM	LTM R27●BD	–
25 A < I < 100 A	LT6 P0M005FM	LT6 P0M005S144	LT6 CT1001	LTM R100●FM	LTM R100●BD	–
100 A < I < 200 A	LT6 P0M005FM	LT6 P0M005S144	LT6 CT2001	LTM R08●FM	LTM R08●BD	LT6 CT2001
200 A < I < 400 A	LT6 P0M005FM	LT6 P0M005S144	LT6 CT4001	LTM R08●FM	LTM R08●BD	LT6 CT4001
400 A < I < 800 A	LT6 P0M005FM	LT6 P0M005S144	LT6 CT8001	LTM R08●FM	LTM R08●BD	LT6 CT8001

0.37 to 400 kW at 690 V: type 2 coordination							
With switch-disconnector, contactor and class 10 controller							
Standard power ratings of 3-phase motors 50/60 Hz in category AC-3		Switch-disconnector (1)	aM fuses		Contactor	TeSys T controller	External current transformer
P	I _e	Reference	Size	Rating	Reference	Reference	Reference
kW	A			A			
0.37	0.64	GS● F	14 x 51	1	LC1 D09	LTM R08●●	–
0.55	0.87	GS● F	14 x 51	2	LC1 D09	LTM R08●●	–
0.75	1.1	GS● F	14 x 51	2	LC1 D09	LTM R08●●	–
1.1	1.6	GS● F	14 x 51	2	LC1 D09	LTM R08●●	–
1.5	2.1	GS● F	14 x 51	4	LC1 D09	LTM R08●●	–
2.2	2.8	GS● F	14 x 51	4	LC1 D09	LTM R08●●	–
3	3.8	GS● F	14 x 51	6	LC1 D09	LTM R08●●	–
4	4.9	GS● F	14 x 51	6	LC1 D09	LTM R08●●	–
5.5	6.7	GS● F	14 x 51	8	LC1 D25	LTM R08●●	–
7.5	8.9	GS● F	14 x 51	10	LC1 D25	LTM R27●●	–
11	12.8	GS● F	14 x 51	16	LC1 D25	LTM R27●●	–
15	17	GS● G	T000	20	LC1 D32	LTM R27●●	–
18.5	21	GS● G	T000	25	LC1 D32	LTM R27●●	–
22	24	GS● G	T000	32	LC1 D40A	LTM R27●●	–
30	32	GS● G	T000	40	LC1 D50A	LTM R100●●	–
37	39	GS● J	22 x 58	50	LC1 D65A	LTM R100●●	–
45	47	GS● J	22 x 58	63	LC1 D80	LTM R100●●	–
55	57	GS● J	22 x 58	80	LC1 D115	LTM R100●●	–
75	77	GS● KK	T00	100	LC1 D115	LTM R100●●	–
90	93	GS● KK	T00	125	LC1 F150	LTM R08●●	LT6 CT2001
110	113	GS● KK	T00	125	LC1 F185	LTM R08●●	LT6 CT2001
132	134	GS● L	T0	160	LC1 F265	LTM R08●●	LT6 CT2001
160	162	GS● N	T1	200	LC1 F265	LTM R08●●	LT6 CT2001
200	203	GS● N	T1	250	LC1 F330	LTM R08●●	LT6 CT4001
220	224	GS● QQ	T2	250	LC1 F400	LTM R08●●	LT6 CT4001
250	250	GS● QQ	T2	315	LC1 F400	LTM R08●●	LT6 CT4001
290	292	GS● QQ	T2	355	LC1 F500	LTM R08●●	LT6 CT4001
315	313	GS● QQ	T2	355	LC1 F500	LTM R08●●	LT6 CT4001
355	354	GS2 S	T3	400	LC1 F630	LTM R08●●	LT6 CT4001
400	400	GS2 S	T3	500	LC1 F630	LTM R08●●	LT6 CT8001

(1) GS●: GS1 for direct operator, GS2 for external operator.

Schneider Electric Industries SAS

www.schneider-electric.com

Head Office
35, rue Joseph Monier
F-92500 Rueil-Malmaison
France

The information provided in this documentation contains general descriptions and/or technical characteristics of the performance of the products contained herein. This documentation is not intended as a substitute for and is not to be used for determining suitability or reliability of these products for specific user applications. It is the duty of any such user or integrator to perform the appropriate and complete risk analysis, evaluation and testing of the products with respect to the relevant specific application or use thereof. Neither Schneider Electric nor any of its affiliates or subsidiaries shall be responsible or liable for misuse of the information contained herein.

Design: Schneider Electric
Photos: Schneider Electric
Printed by: