

# Variable speed drives

## Altivar 61

Catalogue  
October

# 07



For 3-phase motors from 0.75 to 800 kW

*Simply Smart !*

telemecanique.com



This international site allows you to access all the Telemecanique products in just 2 clicks via comprehensive range data-sheets, with direct links to:

- Complete library: technical documents, catalogs, certificates, FAQs, brochures...
- Selection guides from the e-catalog.
- Product discovery sites and their Flash animations.

You will also find illustrated overviews, news to which you can subscribe, a discussion forum, the list of country contacts...

To live automation solutions every day!



### *Flexibility*

- Interchangeable modular functions, to better meet the requirements for extensions
- Software and accessories common to multiple product families



### *Ingenuity*

- Auto-adapts to its environment, "plug & play"
- Application functions, control, communication and diagnostics embedded in the products
- User-friendly operation either directly on the product or remotely



### *Simplicity*

- Cost effective "optimum" offers that make selection easy for most typical applications
- Products that are easy to understand for users, electricians and automation specialists
- User-friendly intuitive programming



### *Compactness*

- High functionality in a minimum of space
- Freedom in implementation



### *Openness*

- Compliance with field bus, connection, and software standards
- Enabling decentralised or remote surveillance via the web with Transparent Ready products





# Variable speed drives

## Altivar 61

---

<b>Selection guide</b> .....	<b>page 2</b>
<b>■ Presentation</b> .....	<b>page 4</b>
<b>■ Altivar 61 variable speed drives</b>	
□ Characteristics .....	<i>page 10</i>
□ Operation .....	<i>page 18</i>
□ UL Type 1/IP 20 and UL Type 12/IP 54 variable speed drives .....	<i>page 20</i>
□ Accessories for UL Type 1/IP 20 and UL Type 12/IP 54 variable speed drives .....	<i>page 26</i>
□ Pre-equipped IP 54 floor-standing enclosure kit .....	<i>page 34</i>
□ IP 23 or IP 54 floor-standing enclosure compact version .....	<i>page 44</i>
□ UL Type 12/IP 54 drives with Vario .....	<i>page 74</i>
□ IP 54 floor-standing enclosure with separate air flows .....	<i>page 78</i>
<b>■ Options</b>	
□ Dialogue .....	<i>page 108</i>
□ Encoder interface cards .....	<i>page 110</i>
□ I/O extension cards .....	<i>page 112</i>
□ Multi-pump cards .....	<i>page 114</i>
□ “Controller Inside” programmable card .....	<i>page 118</i>
□ Communication buses and networks .....	<i>page 126</i>
□ Resistance braking units .....	<i>page 136</i>
□ Braking resistors .....	<i>page 138</i>
□ Reduction of current harmonics	
- DC chokes .....	<i>page 146</i>
- line chokes .....	<i>page 150</i>
- passive filters .....	<i>page 155</i>
□ Additional EMC input filters .....	<i>page 160</i>
□ Output filters	
- motor chokes .....	<i>page 165</i>
- sinus filters .....	<i>page 168</i>
<b>■ Combinations of variable speed drives and options</b> .....	<b>page 170</b>
<b>■ Dimensions</b> .....	<b>page 180</b>
<b>■ Schemes</b> .....	<b>page 206</b>
<b>■ Motor starters</b> .....	<b>page 228</b>
<b>■ Mounting recommendations</b> .....	<b>page 240</b>
<b>■ Functions</b> .....	<b>page 254</b>
<b>■ Function compatibility table</b> .....	<b>page 282</b>
<b>■ PowerSuite software workshop</b> .....	<b>page 284</b>
<b>■ Communication via Modbus TCP network</b> .....	<b>page 288</b>
<b>■ Communication via Fipio bus</b> .....	<b>page 294</b>
<b>■ Communication via Modbus serial link</b> .....	<b>page 298</b>
<b>■ Communication via Modbus Plus network</b> .....	<b>page 302</b>
<b>■ Communication via Uni-Telway bus</b> .....	<b>page 306</b>
<b>■ Communication gateways LUF P</b> .....	<b>page 308</b>
<b>■ Product reference index</b> .....	<b>page 311</b>

# Variable speed drives for asynchronous and synchronous motors

Type of machine	Simple machines	Pumps and fans (building HVAC) (1)	
			
<b>Power range for 50...60 Hz (kW) line supply</b>	<b>0.18...2.2</b>	<b>0.18...15</b>	<b>0.75...75</b>
Single-phase 100...120 V (kW)	0.18...0.75	–	–
Single-phase 200...240 V (kW)	0.18...2.2	0.18...2.2	–
Three-phase 200...230 V (kW)	0.18...2.2	–	–
Three-phase 200...240 V (kW)	–	0.18...15	0.75...30
Three-phase 380...480 V (kW)	–	–	0.75...75
Three-phase 380...500 V (kW)	–	0.37...15	–
Three-phase 525...600 V (kW)	–	0.75...15	–
Three-phase 500...690 V (kW)	–	–	–
<b>Drive</b>	<b>0.5...200 Hz</b>	<b>0.5...500 Hz</b>	<b>0.5...200 Hz</b>
Output frequency	0.5...200 Hz	0.5...500 Hz	0.5...200 Hz
Type of control	Asynchronous motor	Sensorless flux vector control	Sensorless flux vector control, voltage/frequency ratio (2 points), energy saving ratio
	Synchronous motor	–	–
Transient overtorque	150...170% of the nominal motor torque	180% of the nominal motor torque for 2 seconds	110% of the nominal motor torque
<b>Functions</b>			
Number of functions	26	50	50
Number of preset speeds	4	16	7
Number of I/O	1	3	2
Analog inputs	4	6	3
Logic inputs	–	1	1
Analog outputs	1	–	–
Logic outputs	1	2	2
Relay outputs	–	–	–
<b>Communication</b>	Integrated	Modbus and CANopen	Modbus
Available as an option	–	Modbus TCP, DeviceNet, Fipio, PROFIBUS DP	LONWORKS, METASYS N2, APOGEE FLN, BACnet
<b>Cards (available as an option)</b>	–	–	–
<b>Standards and certifications</b>	IEC/EN 61800-5-1, IEC/EN 61800-3 (environments 1 and 2) EN 55011: Group 1, class A and class B. CE, UL, CSA, C-Tick, N998	EN 55011: Group 1, class A and class B with option card, CE, UL, CSA, C-Tick, N998	EN 55011: Group 1, class A and class B with option card, CE, UL, CSA, C-Tick, NOM 117
<b>References</b>	<b>ATV 11</b>	<b>ATV 31</b>	<b>ATV 21</b>
<b>Pages</b>	Please consult our "Soft starters and variable speed drives" catalogue		

(1) Heating, Ventilation and Air Conditioning

**Pumps and fans  
(industrial)**



**Complex machines**



**0.37...800**

- 
- 0.37...5.5
- 
- 0.75...90
- 0.75...630
- 
- 
- 2.2...800

0.5...500 Hz for the entire range  
0.5...1000 Hz up to 37 kW at 200...240 V ~ and 380...480 V ~  
Sensorless flux vector control,  
voltage/frequency ratio (2 or 5 points), energy saving ratio

–  
120...130% of the nominal motor torque for 60 seconds

- > 100
- 8
- 2...4
- 6...20
- 1...3
- 0...8
- 2...4

**Modbus and CANopen**

Modbus TCP, Fipio, Modbus/Uni-Telway, Modbus Plus,  
EtherNet/IP, DeviceNet, PROFIBUS DP, INTERBUS, CC-Link,  
LonWorks, METASYS N2, APOGEE FLN, BACnet

I/O extension cards,  
"Controller Inside" programmable card,  
multi-pump cards

IEC/EN 61800-5-1, IEC/EN 61800-3 (environments 1 and 2, C1 to C3), EN 55011, IEC/EN 61000-4-2/4-3/4-4/4-5/4-6/4-11  
CE, UL, CSA, DNV, C-Tick, NOM 117, GOST

**ATV 61**

20 to 25

**0.37...630**

- 
- 0.37...5.5
- 
- 0.37...75
- 0.75...500
- 
- 
- 1.5...630

1...500 Hz across the entire range  
1...1600 Hz up to 37 kW at 200...240 V ~ and 380...480 V ~  
Sensor/sensorless flux vector control, voltage/frequency ratio (2 or 5 points),  
ENA System

Vector control with or without speed feedback  
220% of the nominal motor torque for 2 seconds  
170% for 60 seconds

- > 150
- 16
- 2...4
- 6...20
- 1...3
- 0...8
- 2...4

Modbus TCP, Fipio, Modbus/Uni-Telway, Modbus Plus, EtherNet/IP, DeviceNet,  
PROFIBUS DP, INTERBUS, CC-Link

Interface cards for incremental, resolver or absolute encoders,  
I/O extension cards,  
"Controller Inside" programmable card

**ATV 71**

Please consult our "Altivar 71 variable speed drives" catalogue and our "Soft starters and  
variable speed drives" catalogue

522835



Ventilation application

522836



Air treatment application

522834



Pumping application

### Applications

The Altivar 61 drive is a frequency inverter for 0.75 kW to 800 kW three-phase asynchronous motors.

It has been designed for state-of-the-art applications in heating, ventilation and air conditioning (HVAC) in industrial and commercial buildings:

- ventilation
- air conditioning
- pumping

The Altivar 61 can reduce operating costs in buildings by optimizing energy consumption whilst improving user comfort.

Its numerous comprehensive options enable it to be adapted and incorporated into electrical installations, sophisticated control systems and building management systems.

With one variant the Altivar 61 can be used for applications involving medium voltage motors.

Observing requirements in respect of electromagnetic compatibility and reducing harmonics were considered right from the design stage.

Depending on the various standard versions (UL Type 1/IP 20 and/or UL Type 12/IP 54), class A or class B EMC filters and DC chokes are either integrated, or available as options.

### Functions

With its macro-configurations and its Simply Start menu, the Altivar 61 drive gets your applications up and running immediately, and its settings are quickly entered with the help of user-friendly dialogue tools.

#### Functions designed specifically for pumping and ventilation applications

- Energy saving ratio, 2 or 5 point quadratic ratio
- Automatic catching a spinning load with speed detection
- Adaptation of current limiting according to speed
- Noise and resonance suppression by means of the switching frequency, which is adjustable up to 16 kHz during operation, by modulating the switching frequency and by the frequency jump.
- Preset speeds
- Integrated PID regulator with preset PID references and automatic/manual ("Auto/Man.") mode
- Electricity and service hours meter
- Fluid absence detection, zero flow and limited flow detection
- Sleep function, wake-up function
- Customer settings with display of physical measurements: bar, l/s, °C, etc.

#### Protection functions

- Motor and drive thermal protection, PTC thermal probe management
- Protection against overloads and overcurrents in continuous operation
- Machine mechanical protection via jump frequency function, output phase rotation.
- Protection of the installation by means of underload, overload and zero flow detection
- Protection via management of multiple faults and configurable alarms

#### Safety functions

- Machine safety via the integrated Power Removal function  
This function prevents the motor from restarting unintentionally; it complies with machine safety standard EN 954-1, category 3 and the standard for functional safety IEC/EN 61508, SIL2 capability (safety control-signalling applied to processes and systems).
- Installation safety is assured by means of the forced operation function with configurable fault inhibiting, direction of operation and references.

637421



ATV 61HC31N4,  
ATV 61HD37M3X, ATV 61HU22N4

107485



ATV 61W075N4,  
ATV 61W075N4C

### A comprehensive offer

The Altivar 61 range of variable speed drives can be used with motor power ratings from 0.75 kW to 800 kW with three types of power supply:

- 200...240 V three-phase, 0.75 kW to 90 kW, UL Type 1/IP 20, (ATV 61H●●●M3, ATV 61H●●●M3X)
- 380...480 V three-phase, 0.75 kW to 630 kW, UL Type 1/IP 20, (ATV 61H●●●N4)
- 380...480 V three-phase, 0.75 kW to 90 kW, UL Type 12/IP 54, (ATV 61W●●●N4, ATV 61W●●●N4C)
- 500...690 V three-phase, 1.5 kW to 800 kW, UL Type 1/IP 20, (ATV 61H●●●Y)

Altivar 61 UL Type 1/IP 20 drives can also be used with motor power ratings from 0.37 kW to 5.5 kW at single-phase 200...240 V, if the motor is derated.

The Altivar 61 drive integrates the Modbus and CANopen protocols as standard, as well as numerous functions. These functions can be extended using communication option cards, I/O extension cards, multi-pump cards and a "Controller Inside" programmable card, see page 9.

External options such as braking resistors, resistance braking units and filters complete the offer, see page 9.

The entire range conforms to international standards IEC/EN 61800-5-1, IEC/EN 61800-2, IEC/EN 61800-3, is UL, CSA, DNV, C-Tick, NOM 117 and GOST certified and has been developed to meet the requirements of directives regarding the protection of the environment (RoHS, WEEE, etc.) as well as those of European Directives so as to meet CE requirements.

### Functional safety and ATEX applications (1)

The Altivar 61 variable speed drive features a safety function that is designed to ensure a motor stop and prevent accidental restarts. This Power Removal safety function means that the drive can be installed as part of the safety system for an electrical/electronic/programmable electronic control system in order to ensure the safety of a machine or industrial process. This function meets the requirements of category 3 of the EN 954-1 machine safety standard, SIL 2 of IEC/EN 61508 and the standard dealing with the functional safety requirements of power drive products: IEC/EN 61800-5-2.

The Power Removal safety function also enables the Altivar 61 variable speed drive to offer protection for motors that are installed in explosive atmospheres (ATEX), see pages 208 and 209.

### Electromagnetic compatibility (EMC)

Reducing harmonics and observing requirements in respect of electromagnetic compatibility were considered right from the design stage. The incorporation of EMC filters in ATV 61H●●●M3 and ATV 61●●●●N4 drives and the observance of requirements in respect of EMC simplifies installation and provides an economical means of ensuring machines meet CE marking requirements.

ATV 61W●●●N4C drives have integrated class B EMC filters, which make them compliant with the requirements of EN 55011 (class B group 1) and IEC/EN 61800-3 (category C1) standards.

The ATV 61H●●●M3X drives have been designed without an EMC filter. Filters are available as an option and can be installed by the user to reduce emission levels, see pages 160 to 163.

### Flexibility and user-friendliness

Altivar 61 has numerous logic and analog inputs and outputs that can be configured to adapt better to your applications.

It integrates the Modbus and CANopen protocols to enhance the performance of your control systems. It also offers the main communication buses for the industry and is easily integrated in building management systems (HVAC) via option cards. It also has multi-pump cards which make it both flexible and user-friendly when managing a number of pumps.

(1) Please refer to the ATEX guide, which is available on our website at [www.telemecanique.com](http://www.telemecanique.com).



537172

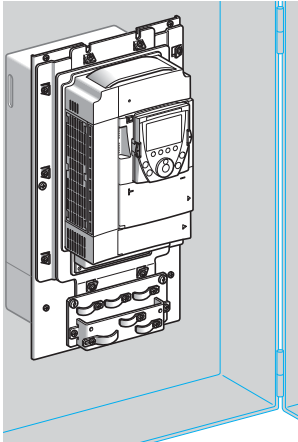

ATV 61HU75N4, flush-mounted

107560



ATV 61E5075N4

PF107545



Kit VW3 A9 544

PF107557



ATV 61EXC2...N4

### Installation

The Altivar 61 drive has been designed to optimize the size of enclosures (floor-standing, wall-mounted, etc):

- The power section, with IP 54 degree of protection, can be easily mounted outside the enclosure using kit **VW3 A9 5...** for flush-mounting in a dust and damp proof enclosure, see page 32. This type of mounting can be used to limit the temperature rise in the enclosure and reduce its size.
- Ambient temperature in the enclosure:
  - 50°C without derating, depending on the rating
  - up to 60°C using control card fan kit **VW3 A9 4...** depending on the rating, and derating the output current if necessary, see page 27
- Mounting side-by-side, see pages 240, 243 and 252

The Altivar 61 drive can also be mounted on a wall in compliance with UL Type 1 conformity with kit **VW3 A9 2...**, and IP 21 or IP 31 conformity with kit **VW3 A9 1...**, see pages 30 and 31.

### Standard versions

The Altivar 61 UL Type 1/IP 20 range of variable speed drives offers various standard versions.

#### Versions with IP 54 degree of protection for difficult environments

To meet the requirements of applications in difficult environments (dusty, humid, etc.), drives can be supplied individually or inside a floor-standing enclosure:

- A drive version with UL Type 12/IP 54 degree of protection (see page 22):
  - 380...480 V ~, 0.75 kW to 90 kW (**ATV 61W...**N4 and **ATV 61W...**N4C)
- A drive version with UL Type 12/IP 54 degree of protection and featuring a Vario switch disconnecter (see pages 74 to 77):
  - 380...480 V ~, 0.75 to 90 kW (**ATV 61E...**N4)
- A drive version ready-assembled in an IP 54 floor-standing enclosure (see pages 78 to 91):
  - 380...415 V ~, 90 kW to 630 kW (**ATV 61EXS...**N4)
  - 500 V and 600...690 V ~, 90 kW to 800 kW (**ATV 61EXS...**N and **ATV 61EXS...**Y)

The **ATV 61EXS...**N4, **ATV 61EXS...**N and **ATV 61EXS...**Y products have been designed for easy set-up in highly polluted environments and, in particular, to ensure optimum enclosure ventilation by keeping the control and power air circuits separate.

- A preassembled kit for creating an IP 54-certified floor-standing enclosure (see pages 34 to 43):

This straightforward and cost-effective solution, which is available by quoting a single reference, provides you with all the mechanical components you need to create an IP 54 floor-standing enclosure (**VW3 A9 541...VW3 A9 551**).

This product has been designed for compatibility with Altivar 61 UL Type 1/IP 20 drives, 110 kW to 630 kW at 380...480 V ~ (**ATV 61HC11N4...HC63N4**).

#### Compact floor-standing enclosure versions for industrial environments and infrastructure contexts

The following product is available to facilitate set-up in industrial environments and infrastructure contexts (tunnels, subways, smoke extraction and pumping, etc.):

- A drive version ready-assembled in an IP 23 or IP 54 compact floor-standing enclosure (see pages 44 to 57):
  - 380...415 V ~, 90 kW to 630 kW (**ATV 61EXC...**N4)
  - 500 V ~, 90 kW to 630 kW (**ATV 71EXC...**N)
  - 600...690 V ~, 110 kW to 800 kW (**ATV 61EXC...**Y)

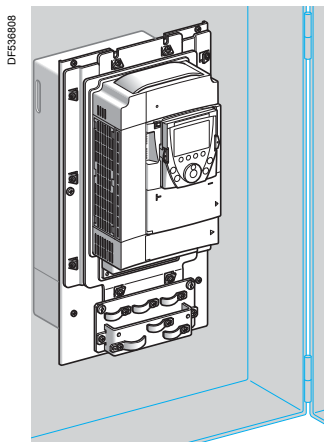

ATV 61HU75N4, flush-mounted

### Mounting options

The Altivar 61 drive can be mounted in a variety of ways for integration into machines.

#### Mounting outside enclosure

The Altivar 61 can be mounted directly on a wall without having to be installed inside an enclosure. UL Type 1 conformity can be achieved using kit **VW3 A9 2●●**, and IP 21 or IP 31 with kit **VW3 A9 1●●**, (see pages 30 and 31).

#### Flush-mounting in a dust and damp proof enclosure

The Altivar 61 drive has been designed to optimize the size of enclosures (floor-standing, wall-mounted, etc).

This type of flush-mounting can be used to reduce the size of enclosure required and to limit the temperature rise inside the enclosure:

- The power section, with IP 54 degree of protection, can be easily mounted outside the enclosure using kit **VW3 A9 5●●** for flush-mounting in a dust and damp proof enclosure, see page 32.
- This type of mounting can lead to ambient temperatures of up to 60°C inside the enclosure without derating. It may be necessary to use a control card fan kit **VW3 A9 4●●** appropriate for the drive rating in order to avoid hot spots, see page 27
- This option permits mounting side-by-side, see pages 240 and 243.

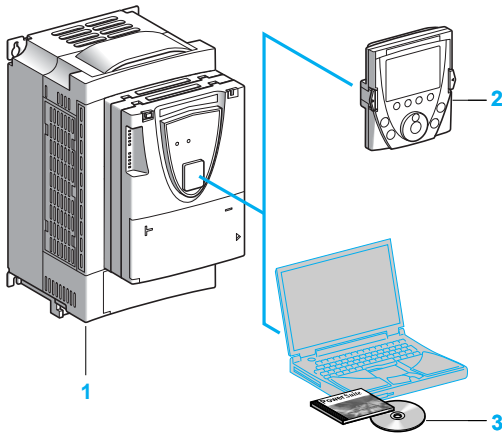

### Dialogue tools

The Altivar 61 **1** is supplied with a remote graphic display terminal **2**:

- The navigation button can be used to access the drop-down menus quickly and easily.
- The graphic screen displays 8 lines of 24 characters of plain text.
- The advanced functions on the display unit can be used to access the more complex drive functions with ease.
- The display screens, menus and parameters can all be customized for the user or the machine.
- Online help screens are available.
- Configurations can be stored and downloaded (four configuration files can be stored).
- The drive can be connected to several other drives via a multidrop link.
- It can be located remotely on an enclosure door with IP 54 or IP 65 degree of protection (UL Type 1/IP20 drives) or built in (UL Type 12/IP 54 drives)
- It is supplied with six languages installed as standard (Chinese, English, French, German, Italian and Spanish). Other languages can be loaded to the flash memory.

Up to 45 kW at 200...240 V and 75 kW at 380...480 V, the Altivar 61 can be controlled using an integrated 7-segment display terminal, see page 24.

For all 500...690 V ~ ratings, the drive is supplied with an integrated 7-segment display terminal and a remote graphic display terminal.

The PowerSuite software workshop **3** can be used for configuration, adjustment, debugging and maintenance of the Altivar 61 drive, like all the other Telemecanique variable speed drives and starters. It can be used via a direct connection, Ethernet, via a modem or a Bluetooth® wireless connection.

### Quick programming

#### Macro-configuration

The Altivar 61 offers quick and easy programming using macro-configurations corresponding to different applications or uses: start-stop, pumping and ventilation, general use, connection to communication networks, PID regulator. Each of these configurations is still fully modifiable.

#### Simply Start menu

The Simply start menu can be used to ensure that the application is working correctly, maximize motor performance and ensure motor protection.

The architecture, the hierarchical parameter structure and the direct access functions all serve to make programming quick and easy, even for the more complex functions.

### Services

The Altivar 61 has numerous built-in maintenance, monitoring and diagnostic functions:

- Drive test functions with diagnostic screen on the remote graphic display terminal
- I/O maps
- Communication maps for the different ports
- Oscilloscope function that can be viewed using the PowerSuite software workshop
- Management of the drive installed base via microprocessors with flash memory
- Remote use of these functions by connecting the drive to a modem via the Modbus port
- Identification of all the drive's component parts as well as the software versions
- Fault logs that can display the values for up to 16 variables in the event of a fault
- Display terminal languages loaded in the flash memory
- A message of up to 5 lines of 24 characters can be stored in the drive.

534783

RUN	Term	+50.00Hz	5.4A
1.1 SIMPLY START <input type="checkbox"/>			
2/3 wire control :		2 wire	
Macro-configuration :		Pumps.Fans	
Standard mot. Freq. :		50Hz IEC	
Rated motor power :		2.2kW	
Rated motor volt. :		400V	
Code	<<	>>	Quick <input type="button" value="v"/>

Simply Start menu

533523

SCF1	Term	+50.00Hz	0.0A
FAULT HISTORY <input type="checkbox"/>			
Short circuit			
Overcurrent			
External FLT			
Overvoltage			
Undervoltage			
Help			Quick <input type="button" value="v"/>

Fault log

522162

SCF1	Term	+50.00Hz	0.0A
MOTOR SHORT CIRCUIT <input type="checkbox"/>			
Check the connection cables and the motor insulation.			
Perform the diagnostic test.			
			Quick <input type="button" value="v"/>

Troubleshooting screen

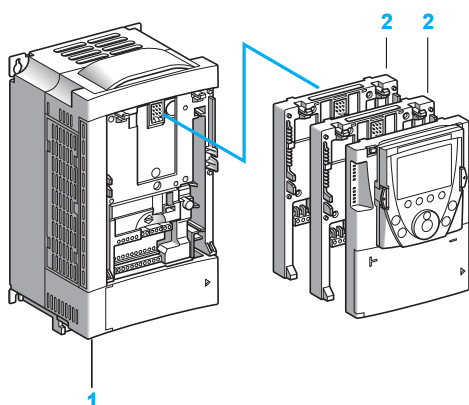

### Options

The Altivar 61 drive **1** can accommodate a maximum of two option cards simultaneously (**1**):

- I/O extension cards **2**, which can be configured to adapt better to your applications, see pages 112 and 113
- Communication cards **2** dedicated to industry or to building management (HVAC), see pages 126 to 135
- Multi-pump cards **2** which make it both flexible and user-friendly when managing a number of pumps, see pages 114 to 117
- "Controller Inside" programmable card **2**. This is used to adapt the drive to specific applications quickly and progressively, by decentralizing the control system functions (programming in IEC 61131-3 compliant languages), see pages 118 to 125.

Various external options can be combined with the Altivar 61:

- Braking units and resistors, see pages 136 to 145
- Line chokes, DC chokes and passive filters (to reduce harmonic currents), see pages 146 to 159
- Additional EMC input filters, see pages 160 to 163
- Motor chokes and sinus filters for long cable runs or to remove the need for shielding, see pages 164 to 169

**Note:** Please refer to the compatibility summary tables to determine which options are available for individual drives, see pages 170 to 179.

### Integration into control systems and building management systems

The Altivar 61 has a combined Modbus or CANopen port for adjustment, monitoring and configuration. A second port is available for connecting a Magelis terminal for machine dialogue.

The Altivar 61 can also be connected to other communication networks using the communication option cards, see pages 126 to 135. All communication protocols for use in industry (Modbus TCP, Fipio, Modbus, Modbus Plus, Ethernet/IP, Uni-Telway, PROFIBUS DP, DeviceNet, INTERBUS and CC-Link) or in building management (LonWorks, METASYS N2, APOGEE FLN, BACnet) are available.

The option of powering the control part separately enables communication to be maintained (monitoring, diagnostics) even if there is no power supply to the power part.

The "Controller Inside" programmable card transforms the drive into an automation island:

- The card has its own I/O; it can also manage those of the drive and an I/O extension card.
- It contains onboard application programs developed in IEC 61131-3 languages, which reduce the control system response time.
- Its CANopen master port enables control of other drives and dialogue with I/O modules and sensors.

The two multi-pump cards can be used to adapt the drive to pump applications. The VW3 A3 502 multi-pump card ensures compatibility of pump applications developed for an Altivar 38 drive with an Altivar 61.

The VW3 A3 503 multi-pump card is used to develop all multi-pump applications. Multi-pump cards have their own I/O. They can manage the drive I/O as well as those for the I/O extension cards. They can also use drive parameters such as speed, current, torque, etc.

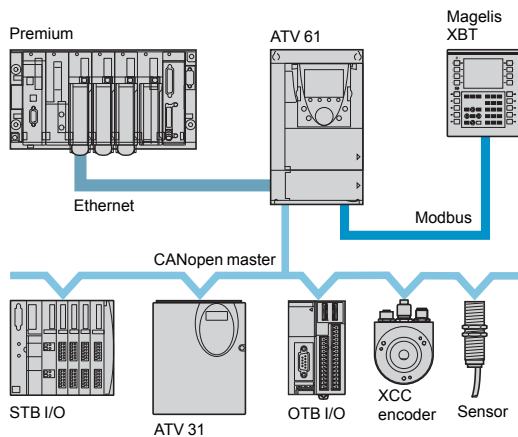

Example of a drive equipped with a communication card and the "Controller Inside" programmable card

(1) The Altivar 61 cannot support more than one option card with the same reference. Consult the summary tables of possible drive, option and accessory combinations, see pages 170 to 179.

### Environmental characteristics

<b>Conforming to standards</b>		Altivar 61 drives have been developed to conform to the strictest international standards and the recommendations relating to electrical industrial control devices (IEC, EN), in particular: low voltage, IEC/EN 61800-5-1, IEC/EN 61800-3 (conducted and radiated EMC immunity and emissions).
EMC immunity		IEC/EN 61800-3, environments 1 and 2 IEC/EN 61000-4-2 level 3 IEC/EN 61000-4-3 level 3 IEC/EN 61000-4-4 level 4 IEC/EN 61000-4-5 level 3 IEC/EN 61000-4-6 level 3 IEC/EN 61000-4-11 (1)
Conducted and radiated EMC emissions for drives	ATV 61H075M3...HU22M3 ATV 61H075N4...HU40N4	IEC/EN 61800-3, environments 1 and 2, categories C1, C2, C3 EN 55011 class A group 1, IEC/EN 61800-3 category C2 With additional EMC filter (2): ■ EN 55011 class B group 1, IEC/EN 61800-3 category C1
	ATV 61HU30M3...HU75M3 ATV 61HU55N4...HC63N4	EN 55011 class A group 2, IEC/EN 61800-3 category C3 With additional EMC filter (2): ■ EN 55011 class A group 1, IEC/EN 61800-3 category C2 ■ EN 55011 class B group 1, IEC/EN 61800-3 category C1
	ATV 61H...M3X	With additional EMC filter (2): ■ EN 55011 class A group 1, IEC/EN 61800-3 category C2 ■ EN 55011 class B group 1, IEC/EN 61800-3 category C1
	ATV 61H...Y	EN 55011 class A group 2, IEC/EN 61800-3 category C3
	ATV 61W075N4...WD90N4	EN 55011 class A group 1, IEC/EN 61800-3 category C2
	ATV 61W075N4C...WD90N4C	EN 55011 class B group 1, IEC/EN 61800-3 category C1
CE		The drives have CE marking in accordance with the European directives on low voltage (2006/95/EC) and EMC (89/336/EEC).
Product certification	ATV 61H...M3 ATV 61HD11M3X...HD45M3X ATV 61HD55M3XD, HD75M3XD ATV 61H075N4...HD75N4 ATV 61HD90N4D...HC50N4D ATV 61H...Y	UL, CSA, C-Tick, NOM 117 and GOST DNV with the dedicated kit, see pages 28 and 29
	ATV 61W...N4, W...N4C	UL, CSA, C-Tick, NOM 117 and GOST
Maximum ambient pollution Definition of insulation	ATV 61H...M3 ATV 61HD11M3X, HD15M3X ATV 61H075N4...HD18N4 ATV 61W075N4...WD15N4 ATV 61W075N4C...WD15N4C	Degree 2 conforming to IEC/EN 61800-5-1
	ATV 61HD18M3X...HD90M3X ATV 61HD22N4...HC63N4 ATV 61H...Y ATV 61WD18N4...WD90N4 ATV 61WD18N4C...WD90N4C	Degree 3 conforming to IEC/EN 61800-5-1 Degree 3 in accordance with UL marking conforming to UL840
Degree of protection		IEC/EN 61800-5-1, IEC/EN 60529
	ATV 61H...M3 ATV 61HD11M3X...HD45M3X ATV 61H075N4...HD75N4 ATV 61HU30Y...HD90Y	IP 21 and IP 41 on upper part IP 20 without blanking plate on upper part of cover IP 54 on lower part (heatsink) IP 21 with accessory VW3 A9 1... , UL Type 1 with accessory VW3 A9 2... , see pages 30 and 31
	ATV 61HD55M3X...HD90M3X ATV 61HD90N4...HC31N4 ATV 61HC11Y...HC40Y	IP 00, IP 41 on the upper part and IP 30 on the front panel and side parts IP 54 on lower part (heatsink) IP 31 with accessory VW3 A9 1... , UL Type 1 with accessory VW3 A9 2... , see pages 30 and 31
	ATV 61HC40N4...HC63N4 ATV 61HC50Y...HC80Y	IP 00, IP 41 on the upper part and IP 30 on the front panel and side parts IP 31 with accessory VW3 A9 1... , see page 31
	ATV 61W075N4...WD90N4 ATV 61W075N4C...WD90N4C	UL Type 12/IP 54
Vibration resistance	ATV 61H...M3 ATV 61HD11M3X...HD45M3X ATV 61HU075N4...HD75N4 ATV 61HU30Y...HD90Y ATV 61W075N4...WD75N4 ATV 61W075N4C...WD75N4C	1.5 mm peak to peak from 3...13 Hz, 1 gn from 13...200 Hz, conforming to IEC/EN 60068-2-6
	ATV 61HD55M3X...HD90M3X ATV 61HD90N4...HC63N4 ATV 61HC11Y...HC80Y ATV 61WD90N4 ATV 61WD90N4C	1.5 mm peak to peak from 3...10 Hz, 0.6 gn from 10...200 Hz, conforming to IEC/EN 60068-2-6

**Note:** Unless specifically indicated on pages 10 to 17, the characteristics of drives with a "337", "S337", "387" or "A24" variant are identical, at equivalent ratings, to the standard drive.

(1) Drive behaviour according to the drive configurations, see pages 272, 273, 279 and 280.  
(2) See table on page 162 to check permitted cable lengths.

Environmental characteristics (continued)			
<b>Shock resistance</b>	ATV 61H●●●M3 ATV 61HD11M3X...HD45M3X ATV 61H075N4...HD75N4 ATV 61HU30Y...HD90Y ATV 61W075N4...WD75N4 ATV 61W075N4C...WD75N4C		15 gn for 11 ms conforming to IEC/EN 60068-2-27
	ATV 61HD55M3X...HD90M3X ATV 61HD90N4...HC16N4 ATV 61HC11Y...HC20Y ATV 61WD90N4 ATV 61WD90N4C		7 gn for 11 ms conforming to IEC/EN 60068-2-27
	ATV 61HC22N4...HC63N4 ATV 61HC25Y...HC80Y		4 gn for 11 ms conforming to IEC/EN 60068-2-27
<b>Environmental conditions Use</b>	ATV 61H●●●M3, ATV 61HD11M3X...HD45M3X, ATV 61H075N4...HD75N4, ATV 61W●●●N4, ATV 61W●●●N4C		IEC 60721-3-3 classes 3C1 and 3S2
	ATV 61H●●●M3S337, ATV 61HD11M3X337...HD45M3X337, ATV 61HD55M3X...HD90M3X, ATV 61H075N4S337...HD75N4S337, ATV 61HD90N4...HC63N4, ATV 61H●●●Y, ATV 61W●●●N4A24		IEC 60721-3-3 class 3C2
<b>Relative humidity</b>			5...95% without condensation or dripping water conforming to IEC 60068-2-3
<b>Ambient air temperature around the device</b>	Operation	°C	For ATV 61H●●●●● drives: - 10...+ 50 without derating, depending on the rating. Up to + 60°C with derating (and with control card fan kit VW3 A9 4●● depending on the rating). For ATV 61W●●●●● drives: - 10...+ 40 without derating. See the derating curves on pages 241 to 253.
	Storage	°C	- 25...+ 70
<b>Maximum operating altitude</b>	ATV 61H●●●M3, ATV 61H●●●M3X, ATV 61H●●●N4, ATV 61W●●●N4, ATV 61W●●●N4C	m	1000 without derating 1000...3000 derating the current by 1% per additional 100 m. Limited to 2000 m for the Corner Grounded distribution network
	ATV 61H●●●Y	m	1000 without derating 1000...2260 derating the current by 1% per additional 100 m.
<b>Operating position</b> Maximum permanent angle in relation to the normal vertical mounting position			

Drive characteristics			
<b>Output frequency range</b>	ATV 61H●●●M3 ATV 61HD11M3X...HD37M3X ATV 61H075N4...HD37N4	Hz	0.5...1000
	ATV 61HD45M3X...HD90M3X ATV 61HD45N4...HC63N4 ATV 61H●●●Y ATV 61W●●●N4 ATV 61W●●●N4C	Hz	0.5...500
<b>Configurable switching frequency</b>	ATV 61H●●●M3, ATV 61HD11M3X...HD45M3X, ATV 61H075N4...HD75N4	kHz	Nominal switching frequency: 12 kHz without derating in continuous operation. Adjustable during operation from 1...16 kHz Above 12 kHz, see the derating curves on pages 240 and 241
	ATV 61HD55M3X	kHz	Nominal switching frequency: 2.5 kHz without derating in continuous operation. Adjustable during operation from 2.5...12 kHz Above 2.5 kHz, see the derating curves on pages 243 and 244
	ATV 61HD75M3X, HD90M3X	kHz	Nominal switching frequency: 2.5 kHz without derating in continuous operation. Adjustable during operation from 2.5...8 kHz Above 2.5 kHz, see the derating curves on pages 243 and 244
	ATV 61HD90N4	kHz	Nominal switching frequency: 4 kHz without derating in continuous operation. Adjustable during operation from 2...8 kHz Above 4 kHz, see the derating curves on pages 243 and 244
	ATV 61HC11N4...HC63N4	kHz	Nominal switching frequency: 2.5 kHz without derating in continuous operation. Adjustable during operation from 2...8 kHz Above 2.5 kHz, see the derating curves on pages 243 to 246.
	ATV 61HU30Y...HD30Y	kHz	Nominal switching frequency: 4 kHz without derating in continuous operation. Adjustable during operation from 2.5...6 kHz Above 4 kHz, see the derating curves on pages 240 and 242
	ATV 61HD37Y...HC80Y	kHz	Nominal switching frequency: 2.5 kHz without derating in continuous operation. Adjustable during operation from 2.5...4.9 kHz Above 2.5 kHz, see the derating curves on pages 240, 242, 243, 247 and 248
	ATV 61W075N4...WD15N4 ATV 61W075N4C...WD15N4C	kHz	Nominal switching frequency: 8 kHz without derating in continuous operation. Adjustable during operation from 2...16 kHz Above 8 kHz, see the derating curves on pages 252 and 253
	ATV 61WD18N4...WD90N4 ATV 61WD18N4C...WD90N4C	kHz	Nominal switching frequency: 4 kHz without derating in continuous operation. Adjustable during operation from 2...16 kHz Above 8 kHz, see the derating curves on pages 252 and 253
<b>Speed range</b>			1...100 in open-loop mode, without speed feedback
<b>Speed accuracy</b>	For a torque variation of 0.2 Tn to Tn		± 10% of nominal slip, without speed feedback
<b>Torque accuracy</b>			± 15% in open-loop mode, without speed feedback
<b>Transient overtorque</b>			130% of the nominal motor torque (typical value at ± 10%) for 60 s
<b>Braking torque</b>			30% of the rated motor torque without braking resistor (typical value) Up to 125% with braking resistor installed as an option, see page 140
<b>Maximum transient current</b>	ATV 61H●●●M3 ATV 61H●●●M3X ATV 61H●●●N4		130% of the nominal drive current for 60 s (typical value)
	ATV 61H●●●Y ATV 61W●●●N4 ATV 61W●●●N4C		120% of the nominal drive current for 60 s (typical value)
<b>Motor control profile</b>	Asynchronous motor		Sensorless Flux Vector Control (FVC) (voltage vector). Voltage/frequency ratio (2 or 5 points). Energy saving ratio
	Synchronous motor		Vector control without speed feedback
<b>Frequency loop</b>			PI regulator with adjustable structure for an adapted speed response (accuracy, speed)
<b>Slip compensation</b>			Automatic whatever the load. Can be suppressed or adjusted Not available in voltage/frequency ratio

Electrical power characteristics			
Power supply	Voltage	V	200 - 15%...240 + 10% single-phase for ATV 61H075M3...HU75M3 200 - 15%...240 + 10% three-phase for ATV 61H...M3 and ATV 61H...M3X 380 - 15%...480 + 10% three-phase for ATV 61...N4 and ATV 61W...N4C 500 - 15%...690 + 10% three-phase for ATV 61H...Y
	Frequency	Hz	50 - 5%...60 + 5%
Signalling			1 red LED: LED lit indicates the presence of drive voltage
Output voltage			Maximum three-phase voltage equal to line supply voltage
Drive noise level			Conforming to directive 86-188/EEC
	ATV 61H075M3, HU15M3 ATV 61H075N4...HU22N4 ATV 61W075N4...WU30N4 ATV 61W075N4C...WU30N4C	dBA	43
	ATV 61HU22M3...HU40M3 ATV 61HU30N4, HU40N4 ATV 61WU40N4, WU55N4 ATV 61WU40N4C, WU55N4C	dBA	54.5
	ATV 61HU55M3 ATV 61HU55N4, HU75N4 ATV 61WU75N4, WD11N4 ATV 61WU75N4C, WD11N4C	dBA	55.6
	ATV 61HU75M3 ATV 61HD11N4 ATV 61WD15N4 ATV 61WD15N4C	dBA	57.4
	ATV 61HD11M3X, HD15M3X ATV 61HD15N4, HD18N4 ATV 61WD18N4, WD22N4 ATV 61WD18N4C, WD22N4C	dBA	60.2
	ATV 61HD18M3X, HD22M3X ATV 61HD22N4 ATV 61HU30Y...HD30Y ATV 61WD30N4 ATV 61WD30N4C	dBA	59.9
	ATV 61HD30M3X...HD45M3X, ATV 61HD30N4, HD37N4 ATV 61WD37N4, WD45N4 ATV 61WD37N4C, WD45N4C	dBA	64
	ATV 61HD45N4...HD75N4 ATV 61HD37Y...HD90Y ATV 61WD55N4...WD90N4 ATV 61WD55N4C...WD90N4C	dBA	63.7
	ATV 61HD55M3X, HD75M3X ATV 61HD90N4, HC11N4	dBA	60.5
	ATV 61HD90M3X ATV 61HC13N4	dBA	69.5
	ATV 61HC16N4, HC22N4	dBA	66
	ATV 61HC11Y...HC20Y	dBA	77
	ATV 61HC25N4, HC31N4	dBA	68
	ATV 61HC25Y...HC40Y	dBA	77
	ATV 61HC40N4, HC50N4	dBA	70
	ATV 61HC63N4	dBA	71
	ATV 61HC50Y...HC80Y	dBA	77
Electrical isolation			Between power and control (inputs, outputs, power supplies)



### Connection cable characteristics

<b>Cable type for</b>	Mounting in an enclosure	Single-strand IEC cable, ambient temperature 45°C, copper 90°C XLPE/EPR or copper 70°C PVC
	Mounting in an enclosure with an IP 21 or IP 31 kit	3-strand IEC cable, ambient temperature 40°C, copper 70°C PVC
	Mounting in an enclosure with a UL Type 1 kit	3-strand UL 508 cable except for choke (2-strand UL 508 cable), ambient temperature 40°C, copper 75°C PVC

### Connection characteristics (terminals for the power supply, the motor, the DC bus and the braking resistor)

Drive terminals	L1/R, L2/S, L3/T, U/T1, V/T2, W/T3	PC/-, PO (1), PA/+	PA, PB	
<b>Maximum wire size and tightening torque</b>	ATV 61H075M3...HU40M3	4 mm <sup>2</sup> , AWG 10		
	ATV 61H075N4...HU40N4	1.4 Nm, 12.3 lb.in		
	ATV 61HU55M3	6 mm <sup>2</sup> , AWG 8		
	ATV 61HU55N4, HU75N4	3 Nm, 26.5 lb.in		
	ATV 61HU75M3	16 mm <sup>2</sup> , AWG 4		
	ATV 61HD11N4	3 Nm, 26.5 lb.in		
	ATV 61HD11M3X, HD15M3X	35 mm <sup>2</sup> , AWG 2		
	ATV 61HD15N4, HD18N4	5.4 Nm, 47.7 lb.in		
	ATV 61HD18M3X, HD22M3X	50 mm <sup>2</sup> , AWG 1/0		
	ATV 61HD22N4...HD37N4	12 Nm, 102.2 lb.in		
	ATV 61HU30Y...HD30Y			
	ATV 61HD30M3X...HD45M3X	150 mm <sup>2</sup> , 300 MCM		
	ATV 61HD45N4...HD75N4	41 Nm, 360 lb.in		
	ATV 61HD37Y...HD90Y			
	ATV 61HD55M3X, HD75M3X	2 x 100 mm <sup>2</sup> , 2 x 250 MCM M10, 24 Nm, 212 lb.in	2 x 100 mm <sup>2</sup> , 2 x 250 MCM M12, 41 Nm, 360 lb.in	60 mm <sup>2</sup> , 250 MCM M8, 12 Nm, 106 lb.in
	ATV 61HD90M3X	2 x 100 mm <sup>2</sup> , 2 x 250 MCM M10, 24 Nm, 212 lb.in	2 x 150 mm <sup>2</sup> , 2 x 250 MCM M12, 41 Nm, 360 lb.in	60 mm <sup>2</sup> , 250 MCM M8, 12 Nm, 106 lb.in
	ATV 61HD90N4, HC11N4	2 x 100 mm <sup>2</sup> , 2 x 250 MCM M10, 24 Nm, 212 lb.in	2 x 100 mm <sup>2</sup> , 2 x 250 MCM M12, 41 Nm, 360 lb.in	60 mm <sup>2</sup> , 250 MCM M8, 12 Nm, 106 lb.in
	ATV 61HC13N4	2 x 100 mm <sup>2</sup> , 2 x 250 MCM M10, 24 Nm, 212 lb.in	2 x 150 mm <sup>2</sup> , 2 x 250 MCM M12, 41 Nm, 360 lb.in	60 mm <sup>2</sup> , 250 MCM M8, 12 Nm, 106 lb.in
	ATV 61HC16N4	2 x 120 mm <sup>2</sup> , 2 x 250 MCM M10, 24 Nm, 212 lb.in	2 x 120 mm <sup>2</sup> , 2 x 250 MCM M10, 24 Nm, 212 lb.in	120 mm <sup>2</sup> , 250 MCM M10, 24 Nm, 212 lb.in
	ATV 61HC11Y...HC20Y			
	ATV 61HC22N4	2 x 150 mm <sup>2</sup> , 2 x 350 MCM M12, 41 Nm, 360 lb.in	2 x 150 mm <sup>2</sup> , 2 x 350 MCM M12, 41 Nm, 360 lb.in	120 mm <sup>2</sup> , 250 MCM M10, 24 Nm, 212 lb.in
	ATV 61HC25N4, HC31N4	4 x 185 mm <sup>2</sup> , 3 x 350 MCM M12, 41 Nm, 360 lb.in	4 x 185 mm <sup>2</sup> , 3 x 350 MCM M12, 41 Nm, 360 lb.in	–
	ATV 61HC25Y...HC40Y			
	ATV 61HC40N4	4 x 185 mm <sup>2</sup> , 4 x 500 MCM M12, 41 Nm, 360 lb.in	8 x 185 mm <sup>2</sup> , 4 x 500 MCM M12, 41 Nm, 360 lb.in	–
	ATV 61HC50N4	<b>R/L1.1, S/L2.1, T/L3.1, R/L1.2, S/L2.2, T/L3.2</b> 2 x 2 x 185 mm <sup>2</sup> , 2 x 2 x 500 MCM M12, 41 Nm, 360 lb.in	8 x 185 mm <sup>2</sup> , 4 x 500 MCM M12, 41 Nm, 360 lb.in	–
		<b>U/T1, V/T2, W/T3</b> 4 x 185 mm <sup>2</sup> , 4 x 500 MCM M12, 41 Nm, 360 lb.in		
	ATV 61HC63N4	<b>R/L1.1, S/L2.1, T/L3.1, R/L1.2, S/L2.2, T/L3.2</b> 2 x 4 x 185 mm <sup>2</sup> , 2 x 3 x 500 MCM M12, 41 Nm, 360 lb.in	8 x 185 mm <sup>2</sup> , 5 x 500 MCM M12, 41 Nm, 360 lb.in	–
	ATV 61HC50Y...HC80Y	<b>U/T1, V/T2, W/T3</b> 6 x 185 mm <sup>2</sup> , 5 x 500 MCM M12, 41 Nm, 360 lb.in		
	ATV 61W075N4...WU55N4	4 mm <sup>2</sup> , AWG 8		
	ATV 61W075N4C...WU55N4C	1.4 Nm, 12.3 lb.in		
	ATV 61WU75N4, WD11N4	6 mm <sup>2</sup> , AWG 6		
	ATV 61WU75N4C, WD11N4C	3 Nm, 26.5 lb.in		
	ATV 61WD15N4	16 mm <sup>2</sup> , AWG 4		
	ATV 61WD15N4C	3 Nm, 26.5 lb.in		
	ATV 61WD18N4, WD22N4	35 mm <sup>2</sup> , AWG 2		
	ATV 61WD18N4C, WD22N4C	5.4 Nm, 47.7 lb.in		
	ATV 61WD30N4	50 mm <sup>2</sup> , AWG 1/0		
	ATV 61WD30N4C	24 Nm, 212 lb.in		
	ATV 61WD37N4, WD45N4	50 mm <sup>2</sup> , AWG 1/0		
	ATV 61WD37N4C, WD45N4C	24 Nm, 212 lb.in		
	ATV 61WD55N4	150 mm <sup>2</sup> , 300 MCM		
	ATV 61WD55N4C	41 Nm, 360 lb.in		
	ATV 61WD75N4	150 mm <sup>2</sup> , 300 MCM		
	ATV 61WD75N4C	41 Nm, 360 lb.in		
	ATV 61WD90N4	150 mm <sup>2</sup> , 300 MCM		
	ATV 61WD90N4C	41 Nm, 360 lb.in		

(1) There is no PO terminal on ATV 61HC11Y...HC80Y drives.

Electrical control characteristics		
Available internal supplies		Short-circuit and overload protection: <ul style="list-style-type: none"> <li>■ 1 x 10.5 V <math>\pm</math> 5% supply for the reference potentiometer (1 to 10 k<math>\Omega</math>), maximum current 10 mA</li> <li>■ 1 x 24 V <math>\pm</math> supply (min. 21 V, max. 27 V), maximum current 200 mA</li> </ul>
External + 24 V power supply (1) (not supplied)		24 V $\pm$ (min. 19 V, max. 30 V) Power 30 W
Analog inputs	AI1-/AI1+	1 bipolar differential analog input $\pm$ 10 V $\pm$ (maximum safe voltage 24 V) Max. sampling time: 2 ms $\pm$ 0.5 ms Resolution: 11 bits + 1 sign bit Accuracy: $\pm$ 0.6% for a temperature variation of 60°C Linearity: $\pm$ 0.15% of the maximum value
	AI2	1 software-configurable voltage or current analog input: <ul style="list-style-type: none"> <li>■ Voltage analog input 0...10 V <math>\pm</math>, impedance 30 k<math>\Omega</math> (max. safe voltage 24 V)</li> <li>■ Current analog input X-Y mA by programming X and Y from 0 to 20 mA, with impedance 242 <math>\Omega</math></li> </ul> Max. sampling time: 2 ms $\pm$ 0.5 ms Resolution: 11 bits Accuracy: $\pm$ 0.6% for a temperature variation of 60°C Linearity: $\pm$ 0.15% of the maximum value
	Other inputs	See option cards
Analog outputs	AO1	1 software-configurable voltage or current analog output or logic output: <ul style="list-style-type: none"> <li>■ Voltage analog output 0...10 V <math>\pm</math>, min. load impedance 470 <math>\Omega</math></li> <li>■ Current analog output X-Y mA by programming X and Y from 0 to 20 mA, max. load impedance 500 <math>\Omega</math></li> </ul> Max. sampling time: 2 ms $\pm$ 0.5 ms Resolution: 10 bits Accuracy: $\pm$ 1% for a temperature variation of 60°C Linearity: $\pm$ 0.2% <ul style="list-style-type: none"> <li>■ Logic output: 10 V, 20 mA max.</li> </ul>
	Other outputs	See option cards
Configurable relay outputs	R1A, R1B, R1C	1 x relay logic output, 1 x "N/C" contact and 1 x "N/O" contact with common point Minimum switching capacity: 3 mA for 24 V $\pm$ Maximum switching capacity: <ul style="list-style-type: none"> <li>■ On resistive load (<math>\cos \varphi = 1</math>): 5 A for 250 V <math>\sim</math> or 30 V <math>\pm</math></li> <li>■ On inductive load (<math>\cos \varphi = 0.4</math> and L/R = 7 ms): 2 A for 250 V <math>\sim</math> or 30 V <math>\pm</math></li> </ul> Max. response time: 7 ms $\pm$ 0.5 ms Electrical service life: 100,000 operations
	R2A, R2B	1 x relay logic output, 1 x "N/O" contact Minimum switching capacity: 3 mA for 24 V $\pm$ Maximum switching capacity: <ul style="list-style-type: none"> <li>■ On resistive load (<math>\cos \varphi = 1</math>): 5 A for 250 V <math>\sim</math> or 30 V <math>\pm</math></li> <li>■ On inductive load (<math>\cos \varphi = 0.4</math> and L/R = 7 ms): 2 A for 250 V <math>\sim</math> or 30 V <math>\pm</math></li> </ul> Max. response time: 7 ms $\pm$ 0.5 ms Electrical service life: 100,000 operations
	Other outputs	See option cards
Logic inputs LI	LI1...LI5	5 programmable logic inputs 24 V $\pm$ , compatible with level 1 PLC, IEC/EN 61131-2 standard Impedance: 3.5 k $\Omega$ Maximum voltage: 30 V Max. sampling time: 2 ms $\pm$ 0.5 ms Multiple assignment makes it possible to configure several functions on one input (example: LI1 assigned to forward and preset speed 2, LI3 assigned to reverse and preset speed 3)
	LI6	1 logic input, switch-configurable as a logic input or as an input for PTC probes Logic input, characteristics identical to inputs LI1...LI5 Input for a maximum of 6 PTC probes mounted in series: <ul style="list-style-type: none"> <li>■ Nominal value &lt; 1.5 k<math>\Omega</math></li> <li>■ Trip resistance 3 k<math>\Omega</math>, reset value 1.8 k<math>\Omega</math></li> <li>■ Short-circuit protection &lt; 50 <math>\Omega</math></li> </ul> This logic input must never be used to protect an ATEX motor in applications in explosive atmospheres (2).
	Positive logic (Source)	State 0 if $\leq$ 5 V or logic input not wired, state 1 if $\geq$ 11 V
	Negative logic (Sink)	State 0 if $\geq$ 16 V or logic input not wired, state 1 if $\leq$ 10 V
Other inputs	See option cards	
Safety input	PWR	1 input for the Power Removal safety function and/or for thermal protection of the ATEX motor in applications in explosive atmospheres (2): <ul style="list-style-type: none"> <li>■ Power supply: 24 V <math>\pm</math> (max. 30 V)</li> <li>■ Impedance: 1.5 k<math>\Omega</math></li> <li>■ State 0 if &lt; 2 V, state 1 if &gt; 17 V</li> </ul>
Maximum I/O wire size and tightening torque		2.5 mm <sup>2</sup> (AWG 14) 0.6 Nm

(1) Please consult our specialist catalogue "Phaseo power supplies and transformers".

(2) Please refer to the ATEX guide, which is available on our website at [www.telemecanique.com](http://www.telemecanique.com).

Electrical control characteristics (continued)			
<b>Acceleration and deceleration ramps</b>			Ramp profiles: <ul style="list-style-type: none"> <li>■ Linear, can be adjusted separately from 0.01 to 9000 s</li> <li>■ S, U or customized</li> </ul> Automatic adaptation of deceleration ramp time if braking capacities exceeded, possible inhibition of this adaptation (use of braking resistor)
<b>Braking to a standstill</b>			By DC injection: <ul style="list-style-type: none"> <li>■ By a command on a programmable logic input</li> <li>■ Automatically as soon as the estimated output frequency drops to &lt; 0.1 Hz, period adjustable from 0 to 60 s or continuous, current adjustable from 0 to 1.2 In (in open-loop mode only).</li> </ul>
<b>Main drive protection and safety features</b>			Thermal protection: <ul style="list-style-type: none"> <li>■ Against overheating</li> <li>■ Of the power stage</li> </ul> Protection against: <ul style="list-style-type: none"> <li>■ Short-circuits between motor phases</li> <li>■ Input phase breaks</li> <li>■ Overcurrents between output phases and earth</li> <li>■ Overvoltages on the DC bus</li> <li>■ A break on the control circuit</li> <li>■ Exceeding the limit speed</li> </ul> Safety function for: <ul style="list-style-type: none"> <li>■ Line supply overvoltage and undervoltage</li> <li>■ Input phase loss, in three-phase</li> </ul>
<b>Motor protection</b> (see page 278)			Thermal protection integrated in drive via continuous calculation of $I^2t$ taking speed into account: <ul style="list-style-type: none"> <li>■ The motor thermal state is saved when the drive is powered down.</li> <li>■ Function can be modified via operator dialogue terminals, depending on the type of motor (force-cooled or self-cooled).</li> </ul> Protection against motor phase breaks Protection with PTC probes
<b>Dielectric strength</b>	ATV 61H●●●M3		Between earth and power terminals: 2830 V ---
	ATV 61H●●●M3X		Between control and power terminals: 4230 V ---
	ATV 61●●●●N4		Between earth and power terminals: 3535 V ---
	ATV 61W●●●N4C		Between control and power terminals: 5092 V ---
	ATV 61H●●●Y		Between earth and power terminals: 3110 V --- Between control and power terminals: 5345 V ---
<b>Insulation resistance to earth</b>			> 1 MΩ (electrical isolation) --- 500 V for 1 minute
<b>Frequency resolution</b>	Display units	<b>Hz</b>	0.1
	Analog inputs	<b>Hz</b>	0.024/50 Hz (11 bits)
Operational safety characteristics			
<b>Protection</b>	Of the machine		Power Removal (PWR) safety function which forces stopping and/or prevents the motor from restarting unintentionally, conforming to EN 954-1 category 3 and draft standard IEC/EN 61800-5-2.
	Of the system process		Power Removal (PWR) safety function which forces stopping and/or prevents the motor from restarting unintentionally, conforming to IEC/EN 61508 level SIL2 and draft standard IEC/EN 61800-5-2.
	Of the ATEX motor (1)		The PWR safety input of the Power Removal safety function is connected to the switching device integrated in the thermal sensor of the ATEX motor (or connected to the switching device of the control device when using PTC ATEX probes).
<b>Response time</b>		<b>ms</b>	≤ 100 in STO (Safe Torque Off)

(1) Please refer to the ATEX guide, which is available on our website at [www.telemecanique.com](http://www.telemecanique.com).

Communication port characteristics			
Modbus protocol			
Type of connection	Modbus RJ45 connector port	Modbus RJ45 network port	
<b>Structure</b>	Physical interface	2-wire RS 485	
	Transmission mode	RTU	
	Transmission speed	Configurable via the display terminal or the PowerSuite software workshop: 9600 bps or 19200 bps	Configurable via the display terminal or the PowerSuite software workshop: 4800 bps, 9600 bps, 19200 bps or 38.4 K bps
	Format	Fixed = 8 bits, even parity, 1 stop	Configurable via the display terminal or the PowerSuite software workshop: - 8 bits, odd parity, 1 stop - 8 bits, even parity, 1 stop - 8 bits, no parity, 1 stop - 8 bits, no parity, 2 stop
	Polarization	No polarization impedances These should be provided by the wiring system (for example, in the master)	
	Address	1 to 247, configurable via the display terminal or the PowerSuite software workshop. 3 addresses can be configured in order to access the drive data, the "Controller Inside " programmable card, the multi-pump card and the communication card respectively. These 3 addresses are identical for the connector and network ports.	
	<b>Services</b>	Device profiles	CiA 402 profile: "Device Profile Drives and Motion Control" I/O profile
Messaging		Read Holding Registers (03) 63 words maximum Write Single Register (06) Write Multiple Registers (16) 61 words maximum Read/Write Multiple Registers (23) 63/59 words maximum Read Device Identification (43) Diagnostics (08)	
Communication monitoring		Can be inhibited. "Time out", which can be set between 0.1 s and 30 s	
<b>Diagnostics</b>	Via LED on ATV 61H●●●M3Z, ATV 61HD11M3XZ...HD45M3XZ, ATV 61H075N4Z...HD75N4Z	One activity LED on integrated 7-segment display terminal. One LED for each port.	
	With graphic display terminal	One activity LED Control word received Reference received For each port: ■ Number of frames received ■ Number of incorrect frames	
CANopen protocol			
<b>Structure</b>	Connector	9-way male SUB-D connector on CANopen adapter. This connects to the Modbus RJ45 network port.	
	Network management	Slave	
	Transmission speed	20 kbps, 50 kbps, 125 kbps, 250 kbps, 500 kbps or 1 Mbps	
	Address (Node ID)	1 to 127, configurable via the display terminal or the PowerSuite software workshop	
	<b>Services</b>	Number of PDOs	3 receive and 3 transmit (PDO1, PDO2 and PDO3)
PDO modes		Event-triggered, Time-triggered, Remotely-requested, Sync (cyclic), Sync (acyclic)	
PDO linking		Yes	
PDO mapping		Configurable (PDO1 and PDO2)	
Number of SDOs		1 server	
Emergency		Yes	
CANopen application layer		CiA DS 301, V 4.02	
Device profiles		CiA 402 profile: "Device Profile Drives and Motion Control" I/O profile	
Communication monitoring	Node Guarding, Heartbeat		
<b>Diagnostics</b>	Via LED on ATV 61H●●●M3Z, ATV 61HD11M3XZ...HD45M3XZ, ATV 61H075N4Z...HD75N4Z	2 LEDs: "RUN" and "ERROR" on integrated 7-segment display terminal	
	With graphic display terminal and PowerSuite software workshop	2 LEDs: "RUN" and "ERROR" Control word received Reference received Display of received PDOs Display of transmitted PDOs State of NMT chart Received PDOs counter Transmitted PDOs counter Reception error counter Transmission error counter	
<b>Description file</b>	A single eds file is supplied for the whole range on the CD-Rom containing the documentation or on the website: <a href="http://www.telemecanique.com">www.telemecanique.com</a> . It contains the description of the drive parameters.		

### Torque characteristics (typical curves)

The curves opposite define the available continuous torque and transient overtorque for both force-cooled and self-cooled motors. The only difference is in the ability of the motor to provide a high continuous torque at less than half the nominal speed.

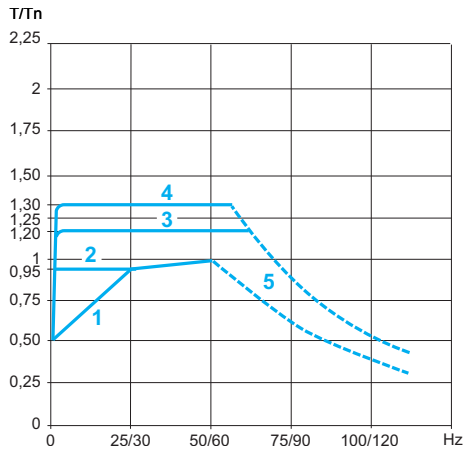

Open loop applications

### Open loop applications

- 1 Self-cooled motor: continuous useful torque (1)
- 2 Force-cooled motor: continuous useful torque
- 3 Overtorque for 60 seconds maximum for ATV 61W●●●●● (UL Type 12/IP 54 drives)
- 4 Overtorque for 60 seconds maximum for ATV 61H●●●●● (UL Type 1/IP 20 drives)
- 5 Torque in overspeed at constant power (2)

### Motor thermal protection

Altivar 61 drives feature thermal protection designed specifically for self-cooled or forced-cooled variable speed motors. The drive calculates the thermal state of the motor even when it is switched off.

This motor thermal protection is designed for a maximum ambient temperature of 40°C around the motor. If the temperature around the motor exceeds 40°C, thermal protection should be provided directly by a thermistor probe (PTC) integrated in the motor. The probes are managed directly by the drive.

(1) For power ratings ≤ 250 W, derating is 20% instead of 50% at very low frequencies.  
 (2) The motor nominal frequency and the maximum output frequency can be adjusted from 10 Hz to 500 Hz or 1000 Hz, depending on the supply voltage and the rating.  
 Check the mechanical overspeed characteristics of the selected motor with the manufacturer.

### Special uses

#### Using Altivar 61 drives with synchronous motors

Altivar 61 drives are also suitable for powering synchronous motors (sinusoidal electromotive force) in open loop mode and are used to achieve performance levels comparable to those obtained with an asynchronous motor in sensorless flux vector control.

This drive/motor combination makes it possible to obtain remarkable speed accuracy and maximum torque, even at zero speed.

The design and construction of synchronous motors are such that they offer enhanced power density and high-speed performance in a compact unit. Drive control for synchronous motors does not cause stalling.

#### Connecting motors in parallel

The nominal current of the drive must be greater than or equal to the sum of the currents of the motors to be controlled.

In this case, provide external thermal protection for each motor using probes or thermal overload relays. For cable runs over a certain length, taking account of all the tap links, it is advisable either to install an output filter between the drive and the motors or to use the overvoltage limitation function.

If several motors are used in parallel, there are two possible scenarios:

- The motors have equal power ratings, in which case the torque characteristics will remain optimized after the drive has been configured
- The motors have different power ratings, in which case the torque characteristics will not be optimized for all the motors

#### ATEX motors in an explosive atmosphere (1)

Use of the "Power Removal" safety function enables the variable speed drive to provide thermal protection in the event of excessive temperature rise of the ATEX motor, but it does not enable it to safely control and regulate the temperature of the ATEX motor.

All motor types ATEX certified for use in zones 1, 21, 2 or 22, and equipped with ATEX thermal sensors can be protected by the Altivar 61 variable speed drive.

#### Switching the motor at the drive output

The drive can be switched when locked or unlocked. If the drive is switched on-the-fly (drive unlocked), the motor is controlled and accelerates until it reaches the reference speed smoothly following the acceleration ramp. This use requires configuration of the automatic catching a spinning load ("catch on the fly") and motor phase loss on output cut functions.

**Typical applications:** loss of safety circuit at drive output, bypass function, switching of motors connected in parallel. On new installations, it is recommended that the "Power Removal" safety function is used.

#### Test on a low power motor or without a motor

In a test or maintenance environment, the drive can be tested without having to use a motor with the same rating as the drive (particularly useful in the case of high power drives). This use requires deactivation of the output phase loss function.

(1) Please refer to the ATEX guide, which is available on our website at [www.telemecanique.com](http://www.telemecanique.com).

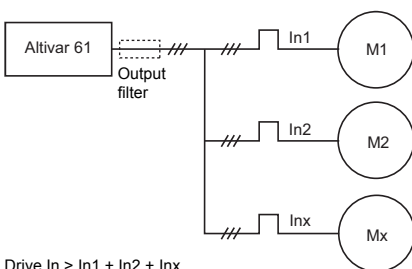

Drive In > In1 + In2 + Inx

**Motors connected in parallel**

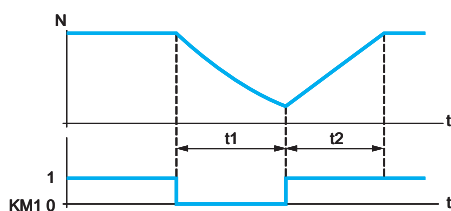
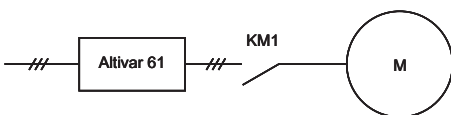

KM1: output contactor  
 t1: deceleration without ramp (freewheel)  
 t2: acceleration with ramp  
 N: motor speed

**Example of loss of output contactor**

# Variable speed drives

## Altivar 61

Supply voltage 200...240 V 50/60 Hz

PF107573



ATV 61H075M3

PF107574



ATV 61HU22M3Z

PF107487



ATV 61HD37M3X

### UL Type 1/IP20 drives

Motor		Line supply				Altivar 61		Reference	Weight	
		Line current (2)		Apparent power 240 V kVA	Max. prospective line Isc kA	Maximum continuous current (1) 230 V A	Max. transient current for 60 s A			
Power indicated on plate (1)	kW	HP	200 V A					240 V A		
<b>Single-phase supply voltage: 200...240 V 50/60 Hz</b>										
	0.37	0.5	6.9	5.8	1.4	5	3	3.6	ATV 61H075M3	3.000
	0.75	1	12	9.9	2.4	5	4.8	5.7	ATV 61HU15M3	3.000
	1.5	2	18.2	15.7	3.7	5	8	9.6	ATV 61HU22M3	4.000
	2.2	3	25.9	22.1	5.3	5	11	13.2	ATV 61HU30M3	4.000
	3	–	25.9	22	5.3	5	13.7	16.4	ATV 61HU40M3 (3)	4.000
	4	5	34.9	29.9	7	5	17.5	21	ATV 61HU55M3 (3)	5.500
	5.5	7.5	47.3	40.1	9.5	22	27.5	33	ATV 61HU75M3 (3)	7.000
<b>Three-phase supply voltage: 200...240 V 50/60 Hz</b>										
	0.75	1	6.1	5.3	2.2	5	4.8	5.7	ATV 61H075M3	3.000
	1.5	2	11.3	9.6	4	5	8	9.6	ATV 61HU15M3	3.000
	2.2	3	15	12.8	5.3	5	11	13.2	ATV 61HU22M3	4.000
	3	–	19.3	16.4	6.8	5	13.7	16.4	ATV 61HU30M3	4.000
	4	5	25.8	22.9	9.5	5	17.5	21	ATV 61HU40M3	4.000
	5.5	7.5	35	30.8	12.8	22	27.5	33	ATV 61HU55M3	5.500
	7.5	10	45	39.4	16.4	22	33	39.6	ATV 61HU75M3	7.000
	11	15	53.3	45.8	19	22	54	64.8	ATV 61HD11M3X (4)	22.000
	15	20	71.7	61.6	25.6	22	66	79.2	ATV 61HD15M3X (4)	22.000
	18.5	25	77	69	28.7	22	75	90	ATV 61HD18M3X (4)	30.000
	22	30	88	80	33.3	22	88	105.6	ATV 61HD22M3X (4)	30.000
	30	40	124	110	45.7	22	120	144	ATV 61HD30M3X (4)	37.000
	37	50	141	127	52.8	22	144	172.8	ATV 61HD37M3X (4)	37.000
	45	60	167	147	61.1	22	176	211.2	ATV 61HD45M3X (4)	37.000
	55	75	200	173	71.9	35	221	265.2	ATV 61HD55M3X (4)	84.000
	75	100	271	232	96.4	35	285	342	ATV 61HD75M3X (4)	84.000
	90	125	336	288	119.7	35	359	431	ATV 61HD90M3X (4)	106.000

(1) These values are given for a nominal switching frequency of 12 kHz up to ATV 61HD45M3X or 2.5 kHz for ATV 61HD55M3X... HD90M3X, for use in continuous operation. The switching frequency is adjustable from 1...16 kHz up to ATV 61HD45M3X, from 2.5...12 kHz for ATV 61HD55M3X and 2.5...8 kHz for ATV 61HD75M3X, HD90M3X.

Above 2.5 or 12 kHz depending on the rating, the drive will reduce the switching frequency automatically in the event of an excessive temperature rise. For continuous operation above the nominal switching frequency, derate the nominal drive current (see derating curves on pages 240, 241, 243 and 244).

(2) Typical value for the indicated motor power and for the maximum prospective line Isc.

(3) A line choke must be used, see page 153.

(4) Drive supplied without EMC filter. EMC filters are available as an option, see page 162.

**Note:** Consult the summary tables of possible drive, option and accessory combinations, see pages 170, 171, 178 and 179.

PF107483



ATV 61HU22N4

PF107575



ATV 61HU40N4Z

PF107481



ATV 61HC31N4

## UL Type 1/IP20 drives

Motor		Line supply				Altivar 61			Reference	Weight
Power indicated on plate (1)	HP	Line current (2)		Apparent power	Max. prospective line Isc	Maximum continuous current (1)		Max. transient current for 60 s		
		380 V	480 V	380 V	kA	380 V	460 V	A		
kW	HP	A	A	kVA	kA	A	A	A	kg	
<b>Three-phase supply voltage: 380...480 V 50/60 Hz</b>										
0.75	1	3.7	3	2.4	5	2.3	2.1	2.7	ATV 61H075N4	3.000
1.5	2	5.8	5.3	3.8	5	4.1	3.4	4.9	ATV 61HU15N4	3.000
2.2	3	8.2	7.1	5.4	5	5.8	4.8	6.9	ATV 61HU22N4	3.000
3	–	10.7	9	7	5	7.8	6.2	9.3	ATV 61HU30N4	4.000
4	5	14.1	11.5	9.3	5	10.5	7.6	12.6	ATV 61HU40N4	4.000
5.5	7.5	20.3	17	13.4	22	14.3	11	17.1	ATV 61HU55N4	5.500
7.5	10	27	22.2	17.8	22	17.6	14	21.1	ATV 61HU75N4	5.500
11	15	36.6	30	24.1	22	27.7	21	33.2	ATV 61HD11N4	7.000
15	20	48	39	31.6	22	33	27	39.6	ATV 61HD15N4	22.000
18.5	25	45.5	37.5	29.9	22	41	34	49.2	ATV 61HD18N4	22.000
22	30	50	42	32.9	22	48	40	57.6	ATV 61HD22N4	30.000
30	40	66	56	43.4	22	66	52	79.2	ATV 61HD30N4	37.000
37	50	84	69	55.3	22	79	65	94.8	ATV 61HD37N4	37.000
45	60	104	85	68.5	22	94	77	112.8	ATV 61HD45N4	44.000
55	75	120	101	79	22	116	96	139.2	ATV 61HD55N4	44.000
75	100	167	137	109.9	22	160	124	192	ATV 61HD75N4	44.000
90	125	166	143	109.3	35	179	179	214.8	ATV 61HD90N4	60.000
110	150	202	168	133	35	215	215	258	ATV 61HC11N4	68.000
132	200	239	224	157.3	35	259	259	310.8	ATV 61HC13N4	74.000
160	250	289	275	190.2	50	314	314	376.8	ATV 61HC16N4	80.000
200	300	357	331	235	50	427	427	512.4	ATV 61HC22N4	110.000
220	350	396	383	260.6	50					
250	400	444	435	292.2	50	481	481	577.2	ATV 61HC25N4	140.000
280	450	494	494	325.1	50	616	616	739.2	ATV 61HC31N4	140.000
315	500	555	544	365.3	50					
355	–	637	597	419.3	50	759	759	910.8	ATV 61HC40N4	215.000
400	600	709	644	466.6	50					
500	700	876	760	576.6	50	941	941	1129.2	ATV 61HC50N4	225.000
560	800	978	858	643.6	50	1188	1188	1425.6	ATV 61HC63N4	300.000
630	900	1091	964	718	50					

(1) These values are given for a nominal switching frequency of 12 kHz up to ATV 61HD75N4, 4 kHz for ATV 61HD90N4 or 2.5 kHz for ATV 61HC11N4...HC63N4, for use in continuous operation.

The switching frequency is adjustable from 1...16 kHz up to ATV 61HD75N4 and 2...8 kHz for ATV 61HD90N4...ATV 61HC63N4.

Above 2.5, 4 or 12 kHz depending on the rating, the drive will reduce the switching frequency automatically in the event of an excessive temperature rise. For continuous operation above the nominal switching frequency, derate the nominal drive current (see derating curves on pages 240, 241, 243 to 246).

(2) Typical value for the indicated motor power and for the maximum prospective line Isc.

**Note:** Consult the summary tables of possible drive, option and accessory combinations, see pages 172, 173, 178 and 179.



# Variable speed drives

## Altivar 61

Supply voltage 380...480 V 50/60 Hz

PF107485



ATV 61W075N4

PF107489



ATV 61WD30N4C

Motor		Line supply				Altivar 61			Reference	Weight
Power indicated on plate (1)		Line current (2)		Apparent power	Max. prospective line	Maximum continuous current (1)		Max. transient current for 60 s		
		380 V	480 V	380 V	Isc	380 V	460 V			
kW	HP	A	A	kVA	kA	A	A		kg	
<b>UL Type 12/IP54 drives with an integrated class A EMC filter</b>										
<b>Three-phase supply voltage: 380...480 V 50/60 Hz</b>										
0.75	1	1.8	1.5	1.2	5	2.3	2.1	2.5	ATV 61W075N4	13.000
1.5	2	3.5	3	2.3	5	4.1	3.4	4.5	ATV 61WU15N4	13.000
2.2	3	5	4.1	3.3	5	5.1	4.8	5.6	ATV 61WU22N4	13.000
3	–	6.7	5.6	4.4	5	7.2	6.2	7.9	ATV 61WU30N4	14.000
4	5	8.8	7.4	5.8	5	9.1	7.6	10	ATV 61WU40N4	16.000
5.5	7.5	11.4	9.2	7.5	22	12	11	13.2	ATV 61WU55N4	16.000
7.5	10	15.8	13.3	10.4	22	16	14	17.6	ATV 61WU75N4	22.000
11	15	21.9	17.8	14.4	22	22.5	21	24.7	ATV 61WD11N4	22.000
15	20	30.5	25.8	20	22	30.5	27	33.5	ATV 61WD15N4	28.000
18.5	25	37.5	32.3	24.7	22	37	34	40.7	ATV 61WD18N4	36.000
22	30	43.6	36.6	28.7	22	43.5	40	47.8	ATV 61WD22N4	36.000
30	40	56.7	46.2	37.3	22	58.5	52	64.3	ATV 61WD30N4	51.000
37	50	69.5	56.8	45.7	22	71.5	65	78.6	ATV 61WD37N4	64.000
45	60	85.1	69.6	56	22	85	77	93.5	ATV 61WD45N4	65.000
55	75	104.8	87	69	35	103	96	113.3	ATV 61WD55N4	92.000
75	100	140.3	113.8	92.3	35	137	124	150.7	ATV 61WD75N4	92.000
90	125	171.8	140.9	113	35	163	156	179.3	ATV 61WD90N4	92.000
<b>UL Type 12/IP54 drives with an integrated class B EMC filter</b>										
<b>Three-phase supply voltage: 380...480 V 50/60 Hz</b>										
0.75	1	1.8	1.5	1.2	5	2.3	2.1	2.5	ATV 61W075N4C	19.000
1.5	2	3.5	3	2.3	5	4.1	3.4	4.5	ATV 61WU15N4C	19.000
2.2	3	5	4.1	3.3	5	5.1	4.8	5.6	ATV 61WU22N4C	20.000
3	–	6.7	5.6	4.4	5	7.2	6.2	7.9	ATV 61WU30N4C	20.000
4	5	8.8	7.4	5.8	5	9.1	7.6	10	ATV 61WU40N4C	23.000
5.5	7.5	11.4	9.2	7.5	22	12	11	13.2	ATV 61WU55N4C	23.000
7.5	10	15.8	13.3	10.4	22	16	14	17.6	ATV 61WU75N4C	32.000
11	15	21.9	17.8	14.4	22	22.5	21	24.7	ATV 61WD11N4C	32.000
15	20	30.5	25.8	20	22	30.5	27	33.5	ATV 61WD15N4C	40.000
18.5	25	37.5	32.3	24.7	22	37	34	40.7	ATV 61WD18N4C	51.000
22	30	43.6	36.6	28.7	22	43.5	40	47.8	ATV 61WD22N4C	50.000
30	40	56.7	46.2	37.3	22	58.5	52	64.3	ATV 61WD30N4C	68.000
37	50	69.5	56.8	45.7	22	71.5	65	78.6	ATV 61WD37N4C	85.000
45	60	85.1	69.6	56	22	85	77	93.5	ATV 61WD45N4C	85.000
55	75	104.8	87	69	35	103	96	113.3	ATV 61WD55N4C	119.000
75	100	140.3	113.8	92.3	35	137	124	150.7	ATV 61WD75N4C	119.000
90	125	171.8	140.9	113	35	163	156	179.3	ATV 61WD90N4C	119.000

(1) These values are given for a nominal switching frequency of 8 kHz up to ATV 61WD15N4 or ATV 61WD15N4C, or 4 kHz for ATV 61WD18N4...WD90N4 or ATV 61WD18N4C...WD90N4C for use in continuous operation.

The switching frequency is adjustable from 2...16 kHz for all ratings.

Above 4 or 8 kHz depending on the rating, the drive will reduce the switching frequency automatically in the event of an excessive temperature rise. For continuous operation above the nominal switching frequency, derate the nominal drive current (see derating curves on pages 252 and 253).

(2) Typical value for the indicated motor power and for the maximum prospective line Isc.

**Note:** Consult the summary tables of possible drive, option and accessory combinations, see pages 174, 175, 178 and 179.

## Variable speed drives

## Altivar 61

Supply voltage 500...690 V 50/60 Hz

PF-107561



ATV 61HU30Y

PF-107563



ATV 61HD45Y

PF-107586



107532

ATV 61HC31Y  
+  
VW3 A4 572 (line choke  
mandatory) (4)

## UL Type 1/IP20 drives

Motor			Line supply				Altivar 61			Reference	Weight
Power indicated on plate (1)			Line current (2)			Max. prospective line Isc	Maximum continuous current (1) (3)				
500 V	575 V	690 V	500 V	600 V	690 V		kA	500 V	575 V	690 V	kg
kW	HP	kW	A	A	A	A		A	A		
Three-phase supply voltage: 500...690 V 50/60 Hz											
2.2	3	3	5.2	4.4	5.2	22	4.5	3.9	4.5	ATV 61HU30Y	30.000
3	–	4	6.8	–	6.6	22	5.8	–	5.5	ATV 61HU40Y	30.000
4	5	5.5	8.6	7.2	8.6	22	7.5	6.1	7.5	ATV 61HU55Y	30.000
5.5	7.5	7.5	11.2	9.5	11.2	22	10	9	10	ATV 61HU75Y	30.000
7.5	10	11	14.6	12.3	15.5	22	13.5	11	13.5	ATV 61HD11Y	30.000
11	15	15	19.8	16.7	20.2	22	18.5	17	18.5	ATV 61HD15Y	30.000
15	20	18.5	24.6	20.7	24	22	24	22	24	ATV 61HD18Y	30.000
18.5	25	22	29	24	27	22	29	27	27	ATV 61HD22Y	30.000
22	30	30	33	28	34	22	35	32	35	ATV 61HD30Y	30.000
30	40	37	48	41	47	22	47	41	43	ATV 61HD37Y	68.000
37	50	45	62	51	55	22	59	52	54	ATV 61HD45Y	68.000
45	60	55	68	57	63	22	68	62	62	ATV 61HD55Y	68.000
55	75	75	79	67	82	22	85	77	84	ATV 61HD75Y	68.000
75	100	90	109	92	101	22	110	99	104	ATV 61HD90Y	68.000
90	125	110	128	113	117	22	136	125	125	ATV 61HC11Y (4)	116.000
110	150	132	153	133	137	28	165	144	150	ATV 61HC13Y (4)	116.000
132	–	160	182	158.9	163	28	200	–	180	ATV 61HC16Y (4)	116.000
160	200	200	218	197	199	35	240	192	220	ATV 61HC20Y (4)	116.000
200	250	250	277	250	257	35	312	242	290	ATV 61HC25Y (4)	207.000
250	350	315	342	311	317	35	390	336	355	ATV 61HC31Y (4)	207.000
315	450	400	426	390	394	35	462	412	420	ATV 61HC40Y (4)	207.000
400	550	500	547	494	505	35	590	528	543	ATV 61HC50Y (4)	435.000
500	700	630	673	613	616	42	740	672	675	ATV 61HC63Y (4)	435.000
630	800	800	847	771	775	42	900	768	840	ATV 61HC80Y (4)	435.000

(1) These values are given for a nominal switching frequency of 4 kHz up to ATV 61HD30Y or 2.5 kHz for ATV 61HD37Y...HC80Y for use in continuous operation.

The switching frequency is adjustable from 2.5...6 kHz up to ATV 61HD30Y and 2.5...4.9 kHz for ATV 61HD37Y...HC80Y drives.

Above 2.5 or 4 kHz, depending on the rating, the drive will reduce the switching frequency automatically in the event of an excessive temperature rise. For continuous operation above the nominal switching frequency, derate the nominal drive current (see derating curves on pages 240, 242, 243, 247 and 248).

(2) Typical value for the indicated motor power and for the maximum prospective line Isc.

(3) The maximum transient current for 60 seconds is equal to 120% of the maximum continuous current.

(4) Line choke mandatory for ATV 61HC11Y...HC80Y drives, unless a special transformer is used (12-pulse) or when using the "387" variant for medium voltage motors, see page 25. The line choke must be ordered separately, see page 154.

**Note:** Consult the summary tables of possible drive, option and accessory combinations, see pages 176 to 179.

# Variable speed drives

## Altivar 61

### Variants

#### Variable speed drive with additional power supply

When the power consumption table does not exceed 200 mA, ATV 61W●●●N4 drives can be supplied with an additional 24 V  $\overline{\text{DC}}$  power supply, which allows additional consumption of 250 mA.

In this case, add **A24** at the end of the reference. For example: ATV 61W075N4 becomes **ATV 61W075N4A24**.

#### Variable speed drive in a reinforced version

This variant enables variable speed drives to operate in specific environmental conditions (see the environmental conditions on page 11).

To order ATV 61H075M3...HD45M3X and ATV 61H075N4...HD75N4 variable speed drives in a reinforced version, add **S337** at the end of the reference. For example: ATV 61H075M3 becomes **ATV 61H075M3S337**.

To order ATV 61HD11M3X...HD45M3X drives in a reinforced version, add **337** at the end of the reference. For example: ATV 61HD11M3X becomes **ATV 61HD11M3X337**.

In the reinforced version, the variable speed drive is supplied with a remote graphic display terminal.

*Note: ATV 61HD55M3X...HD90M3X, ATV 61HD90N4...HC63N4 and ATV 61W●●●N4A24 drives are supplied as standard in a reinforced version.*

#### Variable speed drive with integrated 7-segment display terminal

All drives come with a remote graphic display terminal as standard.

ATV 61H075M3...HD45M3X and ATV 61H075N4...HD75N4 drives can be ordered without this terminal. The drive will then come equipped with an integrated 7-segment display terminal.

In this case, add **Z** at the end of the reference. For example: ATV 61H075M3 becomes **ATV 61H075M3Z**.

ATV 61H●●●Y drives are equipped as standard with a remote graphic display terminal and an integrated 7-segment display terminal.

#### Variable speed drive without DC choke

ATV 61HD55M3X...HD90M3X and ATV 61HD90N4...HC63N4 drives are supplied with a DC choke as standard.

They can be ordered without a DC choke for connections to the DC bus or when using a line choke (see page 150), by adding **D** at the end of the reference.

For example: ATV 61HD55M3X becomes **ATV 61HD55M3XD**.

#### Drive with EMC plate conforming to NEMA type 12 standard

ATV 61W●●●N4 drives are supplied as standard with a European version EMC plate.

To order drives with an EMC plate conforming to NEMA type 12 standard, add **U** at the end of the reference.

For example: ATV 61W075N4 becomes **ATV 61W075N4U**.

#### Note:

- ATV 61H075M3...HD45M3X, ATV 61H075N4...HD75N4, ATV 61W●●●N4C and ATV 61HU30Y...HD90Y drives are supplied as standard with a European version plate for EMC mounting

- ATV 61HD55M3X...HD90M3X, ATV 61HD90N4...HC63N4 and ATV 61HC11Y...HC80Y drives are supplied as standard without a plate for EMC mounting. Depending on the reference, the European version EMC plate is included in the UL Type 1 or IP 31 kit, see pages 30 and 31.

# Variable speed drives

## Altivar 61

### Variants

#### Low voltage drive for medium voltage motors

This variant is an optimized solution for a medium voltage installation since it allows a low voltage drive to be used, thus offering a significant reduction in costs.

Debugging and maintenance are also simpler and therefore less expensive.

This variant is particularly suitable for pumping and ventilation installations requiring low starting torque and/or long cable runs, such as submersible pumps, etc.

The principle consists of using a low voltage drive to control a medium voltage motor.

The drive is supplied by a medium voltage/low voltage step-down transformer and controls the motor via a sinus filter and a low voltage/medium voltage step-up transformer.

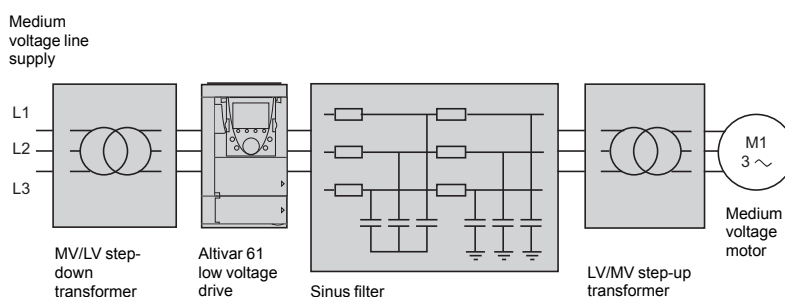

This variant allows use of a low voltage drive covering motor ratings from 110 kW to 800 kW for a medium voltage line supply between 700 V and 6600 V.

To order ATV 61HC11N4D...HC63N4D and ATV 61HC11Y...HC80Y drives in this variant, add **387** at the end of the reference.

For example: ATV 61HC11N4D becomes **ATV 61HC11N4D387**.

The sinus filter must be ordered separately (see page 169) by adding **S387** at the end of the reference.

For example: VW3 A5 207 becomes **VW3 A5 207S387**.

For sinus filters used with ATV 61H●●●Y variable speed drives, please consult your Regional Sales Office.

To determine the size of the drive and the step-up/step-down transformers, please consult your Regional Sales Office.

#### Adaptor for 115 V ~ logic inputs

This adaptor is used to connect 115 V ~ logic signals to the logic inputs on the drive or an I/O extension card.

7 logic inputs with capacitive impedance at 60 Hz of 0.22  $\mu$ F are available for connecting the logic signals:

- Maximum current: 200 mA
- Response time: 5 ms to change from state 0 to state 1, 20 ms to change from state 1 to state 0
- Logic state 0 for a voltage below 20 V, logic state 1 for a voltage between 70 V and 132 V

The power supply must be provided by a 115 V ~ external power supply (min. 70 V, max. 132 V).

#### Reference

Description	Reference	Weight kg
Adaptor for 115 V ~ logic inputs	VW3 A3 101	–

#### Ready-assembled IP 54 base plate (for ATV 61W●●●N4 and ATV 61W●●●N4C drives)

This plate can be used to increase the number of cable connections supported by the drive as standard from 3 to 11.

It is supplied with:

- A metal cable gland for the motor cable
- A special plastic cable gland for the network cable
- Plastic cable glands for the connection of the control cable or options such as communication cards, etc.

#### References

For drive	Type of cable gland		Reference	Weight kg
	Metal	Plastic		
ATV 61W075N4... WU55N4 ATV 61W075N4C... WU55N4C	1 (ISO 25)	1 (ISO 12), 4 (ISO 16) 3 (ISO 20), 1 (ISO 25)	1 (ISO 32) <b>VW3 A9 901</b>	–
ATV 61WU75N4, WD11N4 ATV 61WU75N4C, WD11N4C	1 (ISO 25)	1 (ISO 12), 4 (ISO 16) 3 (ISO 20), 1 (ISO 25)	1 (ISO 32) <b>VW3 A9 902</b>	–
ATV 61WD15N4 ATV 61WD15N4C	1 (ISO 32)	1 (ISO 12), 4 (ISO 16) 1 (ISO 20), 3 (ISO 32)	1 (ISO 32) <b>VW3 A9 903</b>	–
ATV 61WD18N4, WD22N4 ATV 61WD18N4C, WD22N4C	1 (ISO 32)	1 (ISO 12), 4 (ISO 16) 1 (ISO 20), 3 (ISO 32)	1 (ISO 32) <b>VW3 A9 904</b>	–
ATV 61WD30N4 ATV 61WD30N4C	1 (ISO 40)	1 (ISO 12), 4 (ISO 16) 1 (ISO 20), 3 (ISO 40)	1 (ISO 32) <b>VW3 A9 905</b>	–
ATV 61WD37N4, WD45N4 ATV 61WD37N4C, WD45N4C	1 (ISO 40)	1 (ISO 12), 4 (ISO 16) 1 (ISO 20), 3 (ISO 50)	1 (ISO 32) <b>VW3 A9 906</b>	–
ATV 61WD55N4, WD75N4	1 (ISO 50)	1 (ISO 12), 4 (ISO 16) 1 (ISO 20), 1 (ISO 50) 1 (ISO 63)	1 (ISO 32) <b>VW3 A9 907</b>	–
ATV 61WD90N4	1 (ISO 50)	1 (ISO 12), 4 (ISO 16) 1 (ISO 20), 2 (ISO 63)	1 (ISO 32) <b>VW3 A9 908</b>	–
ATV 61WD55N4C, WD75N4C	1 (ISO 50)	1 (ISO 12), 4 (ISO 16) 1 (ISO 20), 1 (ISO 50) 2 (ISO 63)	1 (ISO 32) <b>VW3 A9 909</b>	–
ATV 61WD90N4C	1 (ISO 50)	1 (ISO 12), 4 (ISO 16) 1 (ISO 20), 3 (ISO 63)	1 (ISO 32) <b>VW3 A9 910</b>	–

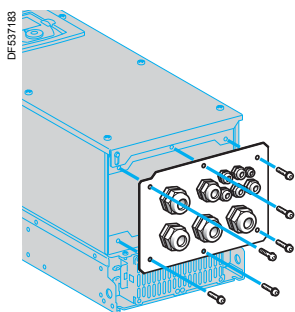

Ready-assembled IP 54 base plate

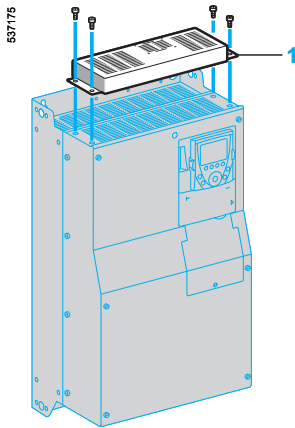

Control card fan kit

#### Control card fan kit

This kit is required for ATV 61HD18M3X...HD45M3X, ATV 61HD22N4...HD75N4 and ATV 61HU30Y...HD90Y drives.

It enables the drive to operate at an ambient temperature of 50°C to 60°C, for example, if it is mounted in an IP 54 enclosure. The circulation of air around the electronic cards prevents the formation of hot spots.

Check the derating to be applied to the drive nominal current (see the derating curves on pages 241 and 242).

The kit **1** is mounted on the upper part of the drive. It is powered by the drive.

It consists of:

- A fan subassembly
- Fixing accessories
- A manual

#### References

For drives	Reference	Weight kg
ATV 61HD18M3X, HD22M3X ATV 61HD22N4 ATV 61HU30Y...HD30Y	<b>VW3 A9 404</b>	–
ATV 61HD30N4, HD37N4	<b>VW3 A9 405</b>	–
ATV 61HD30M3X...HD45M3X	<b>VW3 A9 406</b>	–
ATV 61HD45N4...HD75N4 ATV 61HD37Y...HD90Y	<b>VW3 A9 407</b>	–

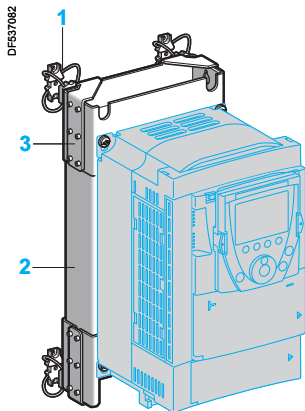

ATV 61HD11M3X drive mounted on  
DNV kit VW3 A9 625

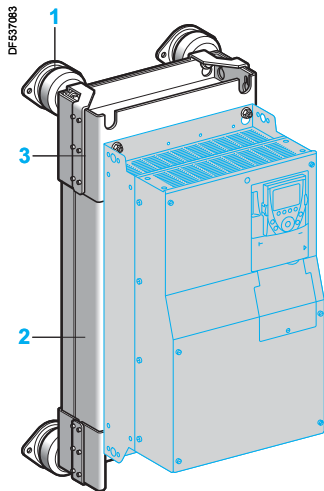

ATV 61HD45N4 drive mounted on  
DNV kit VW3 A9 628

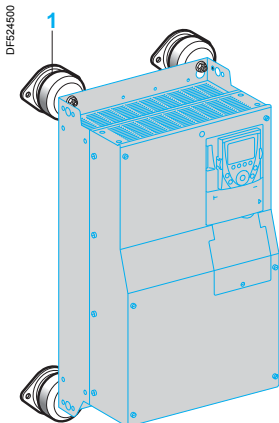

ATV 61H...Y drive mounted on  
DNV kit VW3 A9 64

### DNV kit

This kit enables Altivar 61 variable speed drives to satisfy the requirements of the DNV certification body.

For the following variable speed drives:

- ATV 61H...M3
- ATV 61HD11M3X...HD45M3X
- ATV 61H075N4...HD75N4

The kit consists of:

- Shock-absorbing mounts **1**
- An additional EMC input filter **2**
- EMC filter supports **3**
- Fixing accessories

It is mounted on the back of the variable speed drive on the additional EMC filter supplied with the DNV kit as standard.

### References

For drives	Reference	Weight kg
ATV 61H075M3, HU15M3 ATV 61H075N4...HU22N4	<b>VW3 A9 621</b>	5.400
ATV 61HU22M3...HU40M3 ATV 61HU30N4, HU40N4	<b>VW3 A9 622</b>	7.400
ATV 61HU55M3 ATV 61HU55N4, HU75N4	<b>VW3 A9 623</b>	9.800
ATV 61HU75M3 ATV 61HD11N4	<b>VW3 A9 624</b>	11.200
ATV 61HD11M3X, HD15M3X ATV 61HD15N4, HD18N4	<b>VW3 A9 625</b>	16.500
ATV 61HD18M3X, HD22M3X ATV 61HD22N4	<b>VW3 A9 626</b>	20.000
ATV 61HD30N4, HD37N4	<b>VW3 A9 627</b>	22.500
ATV 61HD30M3X...HD45M3X ATV 61HD45N4...HD75N4	<b>VW3 A9 628</b>	53.500

For ATV 61HU30Y...HD30Y variable speed drives, the kit consists of:

- Shock-absorbing mounts **1**
- An EMC input filter
- Fixing accessories

The shock-absorbing mounts are mounted on the back of the variable speed drive. The EMC filter is positioned beside the unit.

### Reference

For drives	Reference	Weight kg
ATV 61HU30Y...HD30Y	<b>VW3 A9 642</b>	7.500

For ATV 61HD37Y...HD90Y variable speed drives, the kit consists of:

- Shock-absorbing mounts **1**
- An EMC input filter
- A line choke
- Fixing accessories

The shock-absorbing mounts are mounted on the back of the variable speed drive. The EMC filter is positioned beside the unit. The line choke must be installed upstream of the drive.

### Reference

For drives	Reference	Weight kg
ATV 61HD37Y...HD90Y	<b>VW3 A9 643</b>	32.000

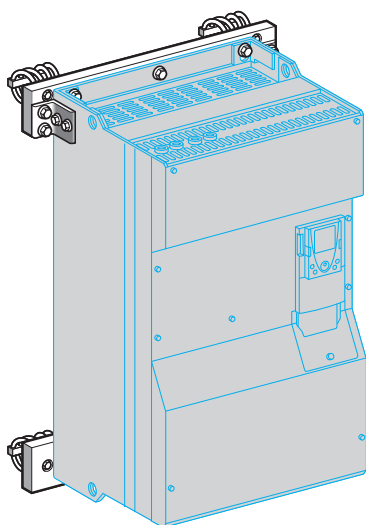

ATV 61HC11N4D drive mounted on  
DNV kit VW3 A9 630

#### DNV kit (continued)

For the following variable speed drives:

- ATV 61HD55M3XD...HD90M3XD
- ATV 61HD90N4D...HC63N4D
- ATV 61HC11Y...HC80Y

The kit consists of:

- Shock-absorbing mounts **1**
- The mechanical fittings (profiles and brackets) required for fixing **2**
- Fixing accessories

It is mounted on the back of the variable speed drive using the mechanical fittings.

#### References

For drives		Line choke (1)	EMC filter(2)	Reference	Weight kg
ATV 61HD55M3XD, HD75M3XD		VW3 A4 562	VW3 A4 410	<b>VW3 A9 629</b>	–
ATV 61HD90N4D		VW3 A4 558	VW3 A4 410	<b>VW3 A9 629</b>	–
ATV 61HC11N4D		VW3 A4 559	VW3 A4 410	<b>VW3 A9 630</b>	–
ATV 61HD90M3XD		VW3 A4 563	VW3 A4 410	<b>VW3 A9 631</b>	–
ATV 61HC13N4D		VW3 A4 560	VW3 A4 410	<b>VW3 A9 632</b>	–
ATV 61HC16N4D		VW3 A4 568	VW3 A4 410	<b>VW3 A9 634</b>	–
ATV 61HC22N4D	Motor P 200 kW	VW3 A4 561	VW3 A4 411	<b>VW3 A9 635</b>	–
	Motor P 220 kW	VW3 A4 569	VW3 A4 411	<b>VW3 A9 636</b>	–
ATV 61HC25N4D		VW3 A4 569	VW3 A4 411	<b>VW3 A9 637</b>	–
ATV 61HC31N4D		VW3 A4 564	VW3 A4 411	<b>VW3 A9 638</b>	–
ATV 61HC40N4D		VW3 A4 565	VW3 A4 412	<b>VW3 A9 639</b>	–
ATV 61HC50N4D		2 x VW3 A4 569	2 x VW3 A4 411	<b>VW3 A9 640</b>	–
ATV 61HC63N4D		2 x VW3 A4 564	2 x VW3 A4 411	<b>VW3 A9 641</b>	–
ATV 61HC11Y, HC13Y (3)		VW3 A4 570	VW3 A4 414	<b>VW3 A9 644</b>	–
ATV 61HC16Y, HC20Y (3)		VW3 A4 571	VW3 A4 414	<b>VW3 A9 645</b>	–
ATV 61HC25Y (3)		VW3 A4 560	VW3 A4 415	<b>VW3 A9 646</b>	–
ATV 61HC31Y, HC40Y (3)		VW3 A4 572	VW3 A4 415	<b>VW3 A9 647</b>	–
ATV 61HC50Y (3)		2 x VW3 A4 568	2 x VW3 A4 415	<b>VW3 A9 648</b>	–
ATV 61HC63Y, HC80Y (3)		2 x VW3 A4 572	2 x VW3 A4 415	<b>VW3 A9 649</b>	–

(1) A line choke must be used. It must be ordered separately (dimensions, see page 197).

(2) An EMC filter must be used. It must be ordered separately (dimensions, see page 201 or consult your Regional Sales Office).

(3) When using a DNV kit, the variable speed drive and the transformer for the fan are mounted separately (dimensions, see pages 180 and 181).



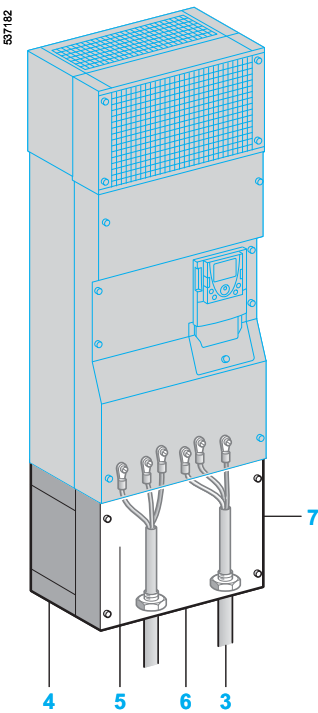
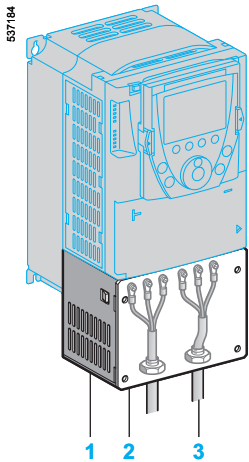

Kits for UL Type 1 conformity

#### Kit for UL Type 1 conformity (mounting outside the enclosure)

When the drive is mounted directly on a wall outside the enclosure, this kit can be used to ensure UL Type 1 conformity when connecting the cables with a tube. The shielding is connected inside the kit.

For ATV 61H●●●M3, ATV 61HD11M3X...HD45M3X, ATV 61H075N4...HD75N4 and ATV 61HU30Y...HD90Y drives, the kit consists of:

- All the mechanical fittings **1** including a pre-cut plate **2** for connecting the tubes **3**
- Fixing accessories
- A manual

For ATV 61HD55M3X...HD90M3X, ATV 61HD90N4...HC31N4, ATV 61HD90N4D...HC31N4D and ATV 61HC11Y...HC40Y drives, the kit consists of:

- An IP 54 casing **4** used to maintain the IP 54 degree of protection for the power section
- An EMC plate **5**
- A UL Type 1 cover **7**
- A pre-drilled plate **6** for connecting the tubes **3**
- Fixing accessories
- A manual

#### References

For drives	Reference	Weight kg
ATV 61H075M3, HU15M3 ATV 61H075N4...HU22N4	<b>VW3 A9 201</b>	1.300
ATV 61HU22M3...HU40M3 ATV 61HU30N4, HU40N4	<b>VW3 A9 202</b>	1.500
ATV 61HU55M3 ATV 61HU55N4, HU75N4	<b>VW3 A9 203</b>	1.800
ATV 61HU75M3 ATV 61HD11N4	<b>VW3 A9 204</b>	2.000
ATV 61HD11M3X, HD15M3X ATV 61HD15N4, HD18N4	<b>VW3 A9 205</b>	2.800
ATV 61HD18M3X, HD22M3X ATV 61HD22N4 ATV 61HU30Y...HD30Y	<b>VW3 A9 206</b>	4.000
ATV 61HD30N4, HD37N4	<b>VW3 A9 207</b>	5.000
ATV 61HD30M3X...HD45M3X	<b>VW3 A9 217</b>	7.000
ATV 61HD45N4...HD75N4 ATV 61HD37Y...HD90Y	<b>VW3 A9 208</b>	7.000
ATV 61HD55M3X, HD75M3X (1) ATV 61HD55M3XD, HD75M3XD (2) ATV 61HD90N4, HC11N4 (1) ATV 61HD90N4D, HC11N4D (2)	<b>VW3 A9 209</b>	9.400
ATV 61HD90M3X (1) ATV 61HD90M3XD (2) ATV 61HC13N4 (1) ATV 61HC13N4D (2)	<b>VW3 A9 210</b>	11.800
ATV 61HC16N4 (1) ATV 61HC16N4D (2) ATV 61HC11Y...HC20Y (3)	<b>VW3 A9 211</b>	11.600
ATV 61HC22N4 (1) ATV 61HC22N4D (2)	<b>VW3 A9 212</b>	14.600
ATV 61HC25N4, HC31N4 (1)	Without braking unit	<b>VW3 A9 213</b> 19.500
ATV 61HC25N4, HC31N4D (2)	With braking unit	<b>VW3 A9 214</b> 19.500
ATV 61HC25Y...HC40Y (3)		

(1) Drives supplied as standard with a DC choke.

(2) Drives supplied as standard without DC choke.

(3) Drives supplied as standard with a transformer for the fan.

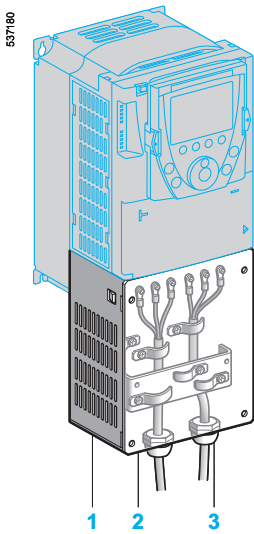

Kit for IP 21 conformity

#### Kit for IP 21 or IP 31 conformity (mounting outside the enclosure)

When the drive is mounted directly on a wall outside the enclosure, this kit can be used to ensure IP 21 or IP 31 degree of protection when connecting the cables with a cable gland.

The shielding is connected inside the kit.

For ATV 61H●●●M3, ATV 61HD11M3X...HD45M3X, ATV 61H075N4...HD75N4 and ATV 61HU30Y...HD90Y drives, the kit conforms to IP 21 degree of protection.

It consists of:

- All the mechanical fittings **1** including a drilled plate **2** for fixing the cable glands **3**
- Fixing accessories
- A manual

For ATV 61HD55M3X...HD90M3X, ATV 61HD90N4...HC63N4, ATV 61HD90N4D...HC63N4D and ATV 61HC11Y...HC80Y drives, the kit conforms to IP 31 degree of protection.

It consists of:

- An IP 54 casing **4** used to maintain the IP 54 degree of protection for the power section
- An EMC plate with cable clamps **5**
- An IP 31 cover **6**
- Fixing accessories
- A manual

#### References

For drives	Degree of protection	Reference	Weight kg
ATV 61H075M3, HU15M3 ATV 61H075N4...HU22N4	IP 21	<b>VW3 A9 101</b>	1.300
ATV 61HU22M3...HU40M3 ATV 61HU30N4, HU40N4	IP 21	<b>VW3 A9 102</b>	1.500
ATV 61HU55M3 ATV 61HU55N4, HU75N4	IP 21	<b>VW3 A9 103</b>	1.800
ATV 61HU75M3 ATV 61HD11N4	IP 21	<b>VW3 A9 104</b>	2.000
ATV 61HD11M3X, HD15M3X ATV 61HD15N4, HD18N4	IP 21	<b>VW3 A9 105</b>	2.800
ATV 61HD18M3X, HD22M3X ATV 61HD22N4 ATV 61HU30Y...HD30Y	IP 21	<b>VW3 A9 106</b>	4.000
ATV 61HD30N4, HD37N4	IP 21	<b>VW3 A9 107</b>	5.000
ATV 61HD30M3X...HD45M3X	IP 21	<b>VW3 A9 117</b>	7.000
ATV 61HD45N4...HD75N4 ATV 61HD37Y...HD90Y	IP 21	<b>VW3 A9 108</b>	7.000
ATV 61HD55M3X, HD75M3X (1) ATV 61HD55M3XD, HD75M3XD (2) ATV 61HD90N4, HC11N4 (1) ATV 61HD90N4D, HC11N4D (2)	IP 31	<b>VW3 A9 109</b>	9.400
ATV 61HD90M3X (1) ATV 61HD90M3XD (2) ATV 61HC13N4 (1) ATV 61HC13N4D (2)	IP 31	<b>VW3 A9 110</b>	11.800
ATV 61HC16N4 (1) ATV 61HC16N4D (2) ATV 61HC11Y...HC20Y (3)	IP 31	<b>VW3 A9 111</b>	11.600
ATV 61HC22N4 (1) ATV 61HC22N4D (2)	IP 31	<b>VW3 A9 112</b>	14.600
ATV 61HC25N4, HC31N4 (1) ATV 61HC25N4, HC31N4D (2) ATV 61HC25Y...HC40Y (3)	Without braking unit IP 31	<b>VW3 A9 113</b>	19.500
	With braking unit IP 31	<b>VW3 A9 114</b>	19.500
ATV 61HC40N4, HC50N4 (1) ATV 61HC40N4D, HC50N4D (2)	IP 31	<b>VW3 A9 115</b>	25.000
ATV 61HC63N4 (1) ATV 61HC63N4D (2) ATV 61HC50Y...HC80Y (3)	IP 31	<b>VW3 A9 116</b>	35.000

(1) Drives supplied as standard with a DC choke.

(2) Drives supplied as standard without DC choke.

(3) Drives supplied as standard with a transformer for the fan.

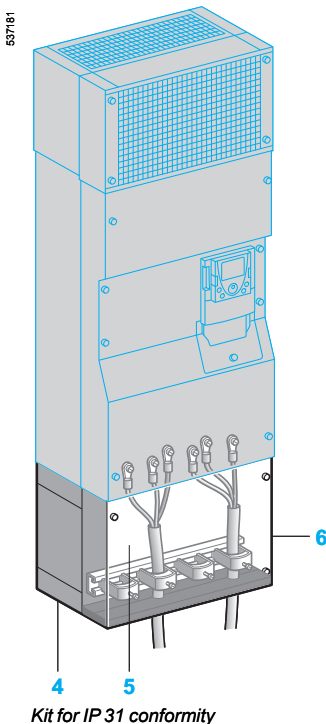

Kit for IP 31 conformity

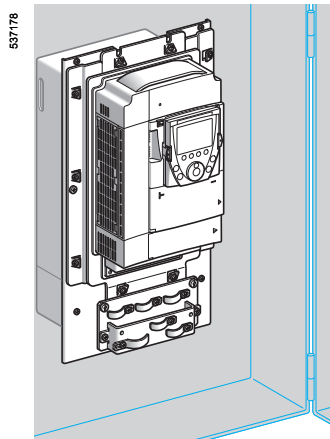

ATV 61HU75N4, flush-mounted

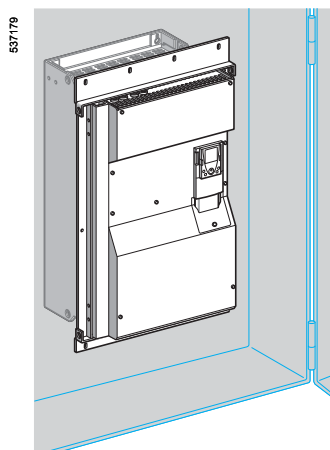

ATV 61HC31N4D, flush-mounted

### Kit for flush-mounting in a dust and damp proof enclosure (for ATV 61W●●●●● drives)

This kit can be used to mount the drive power section outside the enclosure (IP 54 degree of protection), which reduces the power dissipated into the enclosure (see pages 249 and 250).

It is available for ATV 61H●●●M3, ATV 61H●●●M3X, ATV 61HD55M3XD...HD90M3XD, ATV 61H075N4...HC31N4, ATV 61HD90N4D...HC31N4D and ATV 61HU30Y...HC40Y drives.

With this type of mounting, the maximum internal temperature in the enclosure can then reach 60°C without it being necessary to derate the drive current. Between 50°C and 60°C, a control card fan kit must be used for the ATV 61HD18M3X...HD45M3X, ATV 61HD22N4...HD75N4 and ATV 61HU30Y...HD90Y drives to prevent hot spots, see page 27.

The back of the enclosure must be drilled and cut out for this type of mounting.

The kit consists of:

- A metal frame of the right size for the drive rating
- Corner pieces
- Seals
- A fan support (this can be used to move the fans so that they can be accessed from the front of the enclosure)
- Fixing accessories
- A cutting and drilling template
- A manual

### References

For drives	Reference	Weight kg
ATV 61H075M3, HU15M3 ATV 61H075N4...HU22N4	<b>VW3 A9 501</b>	2.700
ATV 61HU22M3...HU40M3 ATV 61HU30N4, HU40N4	<b>VW3 A9 502</b>	3.100
ATV 61HU55M3 ATV 61HU55N4, HU75N4	<b>VW3 A9 503</b>	3.700
ATV 61HU75M3 ATV 61HD11N4	<b>VW3 A9 504</b>	4.600
ATV 61HD11M3X, HD15M3X ATV 61HD15N4, HD18N4	<b>VW3 A9 505</b>	4.900
ATV 61HD18M3X, HD22M3X ATV 61HD22N4 ATV 61HU30Y...HD30Y	<b>VW3 A9 506</b>	3.900
ATV 61HD30N4, HD37N4	<b>VW3 A9 507</b>	4.200
ATV 61HD30M3X...HD45M3X	<b>VW3 A9 508</b>	4.900
ATV 61HD45N4...HD75N4 ATV 61HD37Y...HD90Y	<b>VW3 A9 509</b>	5.200
ATV 61HD55M3X, HD75M3X ATV 61HD55M3XD, HD75M3XD ATV 61HD90N4, HC11N4, ATV 61HD90N4D, HC11N4D	<b>VW3 A9 510 (1)</b>	5.100
ATV 61HD90M3X ATV 61HD90M3XD ATV 61HC13N4 ATV 61HC13N4D	<b>VW3 A9 511 (1)</b>	3.600
ATV 61HC16N4 (1) ATV 61HC16N4D (1) ATV 61HC11Y...HC20Y (2)	<b>VW3 A9 512</b>	4.300
ATV 61HC22N4 ATV 61HC22N4D	<b>VW3 A9 513 (1)</b>	4.700
ATV 61HC25N4, HC31N4 (1) Without braking unit	<b>VW3 A9 514</b>	4.700
ATV 61HC25N4D, HC31N4D (1) With braking unit ATV 61HC25Y...HC40Y (2)	<b>VW3 A9 515</b>	4.700

(1) The procedure for cutting out and drilling the enclosure varies depending on whether the DC choke is present or not:

- Drives supplied with DC choke: ATV 61HD55M3X...HD90M3X, ATV 61HD90N4...HC31N4
- Drives supplied without DC choke: ATV 61HD55M3XD...HD90M3XD, ATV 61HD90N4D...HC31N4D See pages 190 to 193.

(2) Drives supplied as standard with transformer for the fan. In this case, cut out and drill the enclosure for the transformer, see page 193.

## Variable speed drives

## Altivar 61

## Options: Accessories

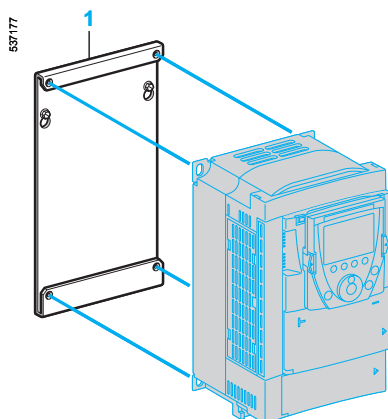

VW3 A9 304

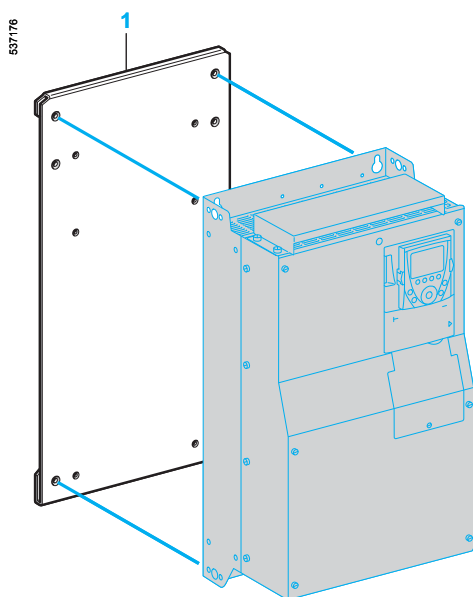

VW3 A9 312

## Substitution kit for Altivar 38 drives

This kit 1 is used to install an Altivar 61 drive in place of an Altivar 38 drive using the same fixing holes. It includes the mechanical adapters required for mounting.

## References

Old drive	Motor Power		Replaced by	Reference	Weight kg
	kW	HP			
<b>Replacing an Altivar 38 drive with an integrated EMC filter</b>					
<b>Three-phase supply voltage: 380...480 V 50/60 Hz</b>					
ATV 38HU18N4	0.75	1	ATV 61H075N4	VW3 A9 302	—
ATV 38HU29N4	1.5	2	ATV 61HU15N4	VW3 A9 302	—
ATV 38HU41N4	2.2	3	ATV 61HU22N4	VW3 A9 302	—
ATV 38HU54N4	3	—	ATV 61HU30N4	VW3 A9 304	—
ATV 38HU72N4	4	5	ATV 61HU40N4	VW3 A9 304	—
ATV 38HU90N4	5.5	7.5	ATV 61HU55N4	VW3 A9 305	—
ATV 38HD12N4	7.5	10	ATV 61HU75N4	VW3 A9 306	—
ATV 38HD16N4	11	15	ATV 61HD11N4	VW3 A9 307	—
ATV 38HD23N4	15	20	ATV 61HD15N4	VW3 A9 308	—
ATV 38HD25N4	18.5	25	ATV 61HD18N4	VW3 A9 309	—
ATV 38HD28N4	22	30	ATV 61HD22N4	VW3 A9 310	—
ATV 38HD33N4	30	40	ATV 61HD30N4	VW3 A9 310	—
ATV 38HD46N4	37	50	ATV 61HD37N4	VW3 A9 312	—
ATV 38HD54N4	45	60	ATV 61HD45N4	VW3 A9 312	—
ATV 38HD64N4	55	75	ATV 61HD55N4	VW3 A9 312	—
ATV 38HD79N4	75	100	ATV 61HD75N4	VW3 A9 312	—

## Replacing an Altivar 38 drive without an integrated EMC filter

Three-phase supply voltage: 380...480 V 50/60 Hz

ATV 38HD25N4X	18.5	25	ATV 61HD18N4	VW3 A9 309	—
ATV 38HD28N4X	22	30	ATV 61HD22N4	VW3 A9 310	—
ATV 38HD33N4X	30	40	ATV 61HD30N4	VW3 A9 310	—
ATV 38HD46N4X	37	50	ATV 61HD37N4	VW3 A9 312	—
ATV 38HD54N4X	45	60	ATV 61HD45N4	VW3 A9 312	—
ATV 38HD64N4X	55	75	ATV 61HD55N4	VW3 A9 312	—
ATV 38HD79N4X	75	100	ATV 61HD75N4	VW3 A9 312	—

## Substitution kit for Altivar 58 drives

This kit 1 is used to install an Altivar 61 drive in place of an Altivar 58 drive for variable torque applications, using the same fixing holes. It includes the mechanical adapters required for mounting.

## References

Old drive	Motor Power		Replaced by	Reference	Weight kg
	kW	HP			
<b>Three-phase supply voltage: 500 V 50/60 Hz</b>					
ATV 58HD28N4	22	30	ATV 61HD30Y	VW3 A9 310	—
ATV 58HD33N4	30	40	ATV 61HD37Y	VW3 A9 312	—
ATV 58HD46N4	37	50	ATV 61HD45Y	VW3 A9 312	—
ATV 58HD54N4	45	60	ATV 61HD55Y	VW3 A9 312	—
ATV 58HD64N4	55	75	ATV 61HD75Y	VW3 A9 312	—
ATV 58HD79N4	75	100	ATV 61HD90Y	VW3 A9 312	—

# Variable speed drives

Altivar 61

Pre-equipped IP 54 floor-standing enclosure kit

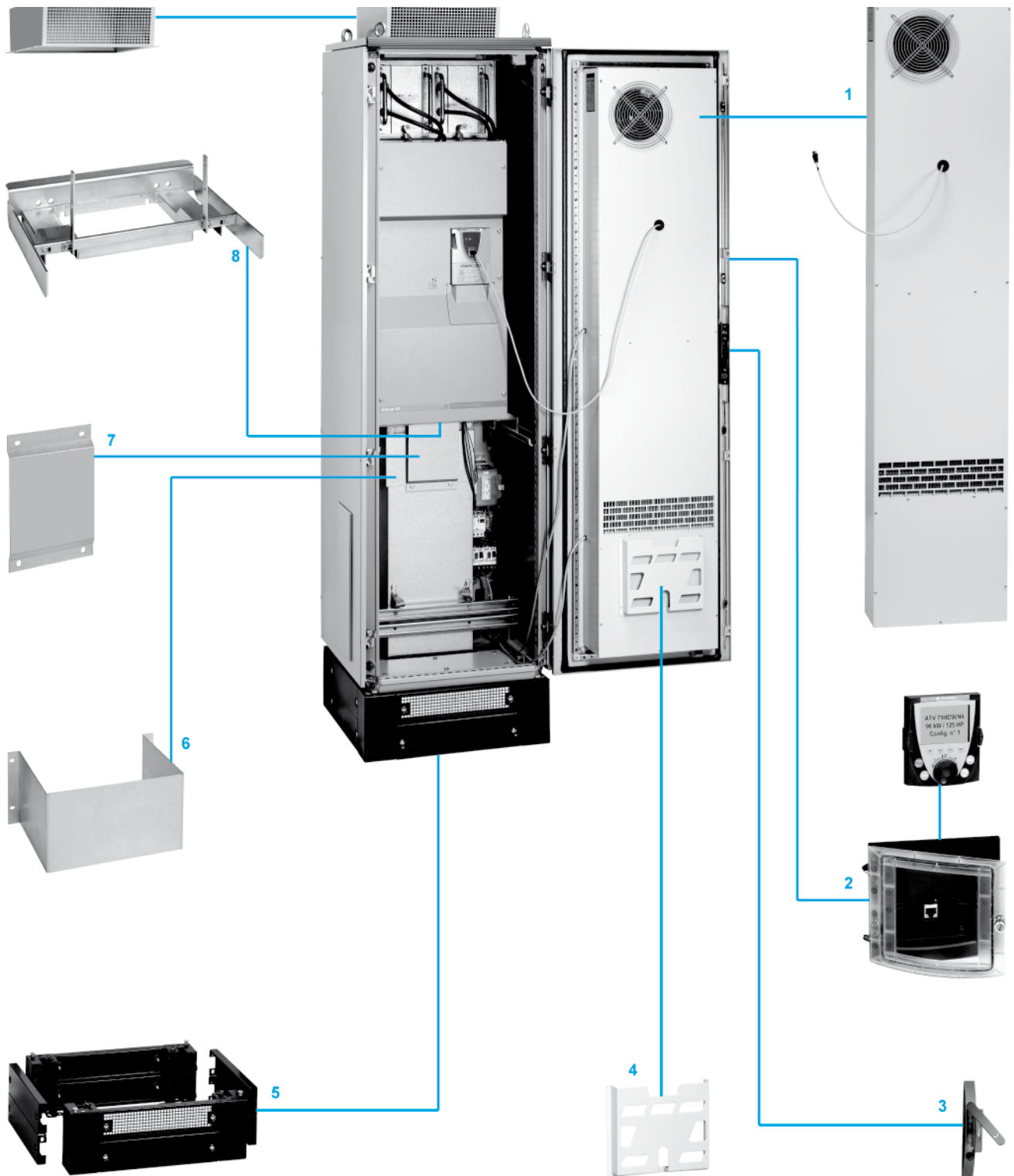

# Variable speed drives

## Altivar 61

### Pre-equipped IP 54 floor-standing enclosure kit

#### Presentation

The pre-equipped kit solution is used to create an IP 54 certified floor-standing enclosure for 110 kW to 500 kW UL Type 1/IP 20 Altivar 61 variable speed drives for a 380...480 V three-phase power supply.

This kit has been designed to:

- Reduce the implementation time with:
  - Simplified assembly
  - Optimized thermal and mechanical dimensioning

The cooling systems used enable the equipment to be installed in difficult and dusty environments.

There are two types of cooling:

- Kits **VW3 A9 541** and **VW3 A9 542** with a single air circuit for the power section
- Kits **VW3 A9 543...548** with two separate air circuits:
  - One for the power section
  - One for the control section

So that the air circuit for the control section is not contaminated, an air/air heat exchanger is incorporated in the enclosure door (see page 36).

#### Description

The kit consists of:

- Air/air heat exchanger (except for enclosure kits **VW3 A9 541** and **VW3 A9 542**) **1**
- IP 65 graphic display terminal remote mounting kit **2**
- Handle with a pushbutton-operated opening mechanism **3**
- Document holder **4**
- Plinth **5**
- Lower air duct **6**
- EMC plate **7**
- Drive support **8**
- Roof extension **9**
- Upper air duct
- Altivar 61 and 61 identification labels
- 24 V  $\overline{\text{---}}$ , 600 mA supplementary power supply
- Fixing accessories
- Seals
- Technical documentation containing all the:
  - Parts lists
  - Electrical diagrams
  - Mechanical assembly drawings

#### Options

For adding accessories or options, there are two additional 600 and 800 mm empty enclosure kits supplied in kit form.

The additional empty enclosure kit must be installed on the left side of the pre-equipped IP 54 enclosure kit. In this case, the left-hand panel of the pre-equipped IP 54 enclosure kit is mounted on the left side of the additional empty enclosure kit which is supplied without side panels.

#### Ventilation

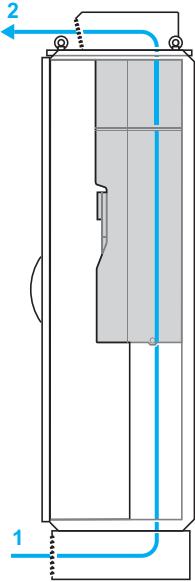

#### VW3 A9 541, VW3 A9 542

The enclosure ventilation is optimized using a single air circuit cooling the power section.

**Power section:**

- 1 Air inlet via the plinth
- 2 Air outlet located on the enclosure roof

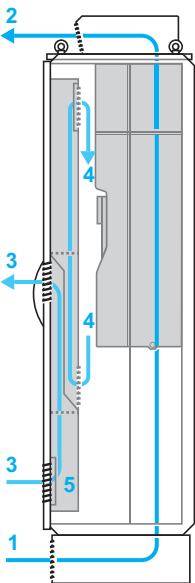

#### VW3 A9 543...A9 548

The enclosure ventilation is optimized using two separate air circuits cooling the power section and the control section.

The air circulating in the power section is isolated from the control section thereby ensuring better protection against the entry of contaminants (in hostile and dusty environments).

**Power section:**

- 1 Air inlet via the plinth
- 2 Air outlet located on the enclosure roof

**Control section:**

Cooling system using an air/air exchanger:

- 3 External air circuit for cooling the exchanger 5
- 4 Internal air circuit cooled by the exchanger 5

#### Characteristics

Maximum temperature	<ul style="list-style-type: none"> <li>■ + 45°C outside the enclosure</li> <li>■ + 50°C inside the enclosure (internal temperature monitored by a thermostat which stops the equipment)</li> </ul>
Colour of SAREL Spacial 6000 Cell Enclosure	<ul style="list-style-type: none"> <li>RAL 7032 for case</li> <li>RAL 7022 for plinth</li> </ul>
Connections	Cable entry via the enclosure bottom or from the left
Available internal supplies	<ul style="list-style-type: none"> <li>■ 1 x 24 V <math>\overline{\text{---}}</math> drive supply (min. 21 V, max. 27 V), maximum current 200 mA</li> <li>■ 1 x 24 V <math>\overline{\text{---}}</math> additional supply, maximum current 600 mA</li> </ul>
Accessories (1)	SAREL Spacial 6000 Cell compatible

(1) Please refer to the website [www.sarel.fr](http://www.sarel.fr)

## Variable speed drives

## Altivar 61

## Pre-equipped IP 54 floor-standing enclosure kit



VW3 A9 543...A9 546

## References

Description	Used with	Reference	Weight kg
Pre-equipped IP 54 floor-standing enclosure kit	ATV 61HC11N4 (1)	VW3 A9 541	220.000
	ATV 61HC13N4 (1)	VW3 A9 542	220.000
	ATV 61HC16N4 (1)	VW3 A9 543	252.000
	ATV 61HC22N4 (1)	VW3 A9 544	252.000
	ATV 61HC25N4 (1) without braking unit ATV 61HC31N4 (1) without braking unit	VW3 A9 545	300.000
	ATV 61HC25N4 (1) with braking unit VW3 A7 101 (2) ATV 61HC31N4 (1) with braking unit VW3 A7 101 (2)	VW3 A9 546	300.000
	ATV 61HC40N4 (1) without braking unit ATV 61HC50N4 (1) without braking unit	VW3 A9 547	360.000
	ATV 61HC63N4 (1) without braking unit	VW3 A9 548	470.000
	VW3 A7 102 (2)	VW3 A9 549	252.000
	Empty enclosure kit additional 600 mm	Options and accessories (3)	VW3 A9 550
Empty enclosure kit additional 800 mm	Options and accessories (3)	VW3 A9 551	210.000

(1) Drive to be ordered separately, see page 21.

(2) To be ordered separately, see page 137. Braking unit VW3 A7 102 for ATV 61HC40N4...HC63N4 variable speed drive.

(3) For any additional information, please consult your Regional Sales Office.



## Variable speed drives

Altivar 61

Pre-equipped IP 54 floor-standing enclosure kit

### VW3 A9 541, 542 (1)

Assembled kit

Fixing the kit to the floor

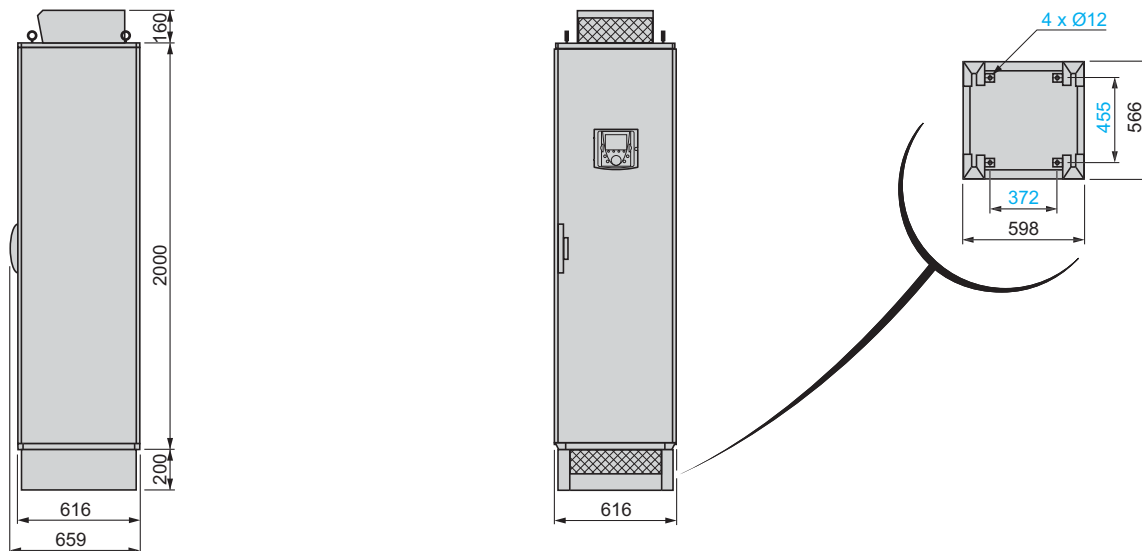

### VW3 A9 543...546 (1)

Assembled kit

Fixing the kit to the floor

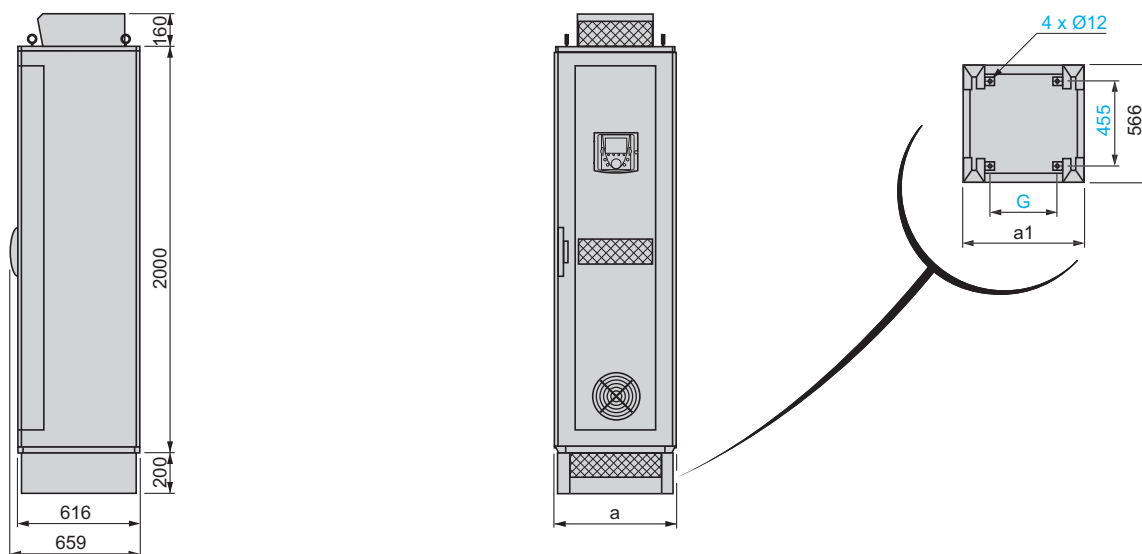

VW3	a	a1	G
A9 543	616	598	372
A9 544	616	598	372
A9 545	816	798	572
A9 546	816	798	572

(1) For detail of location of terminals, see page 41.

**VW3 A9 547, 548 (1)**

Assembled kit

Fixing the kit to the floor

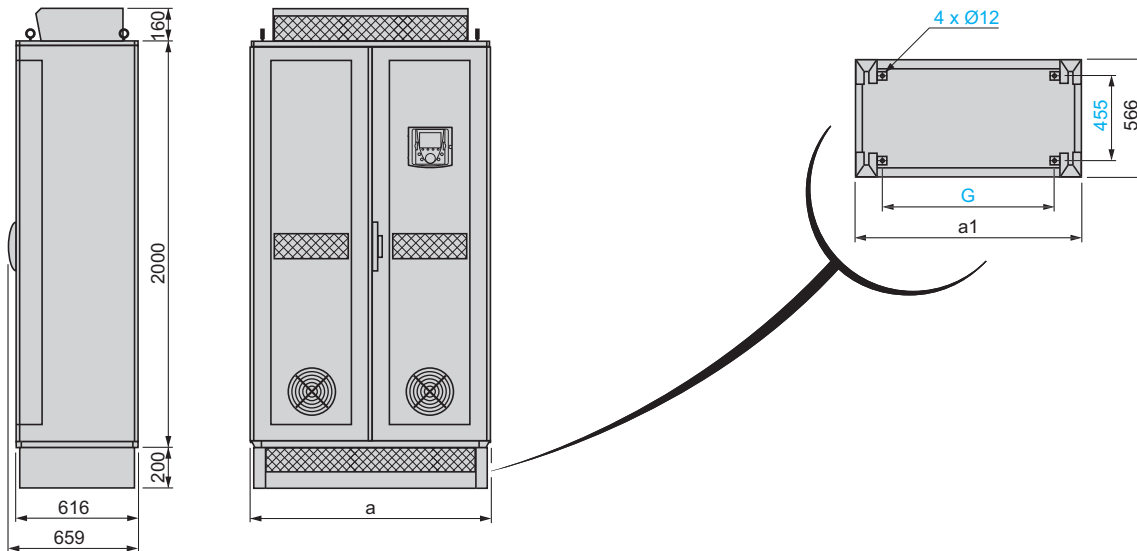

VW3	a	a1	G
A9 547	1016	998	772
A9 548	1216	1198	972

**VW3 A9 549 (1)**

Assembled kit

Fixing the kits to the floor

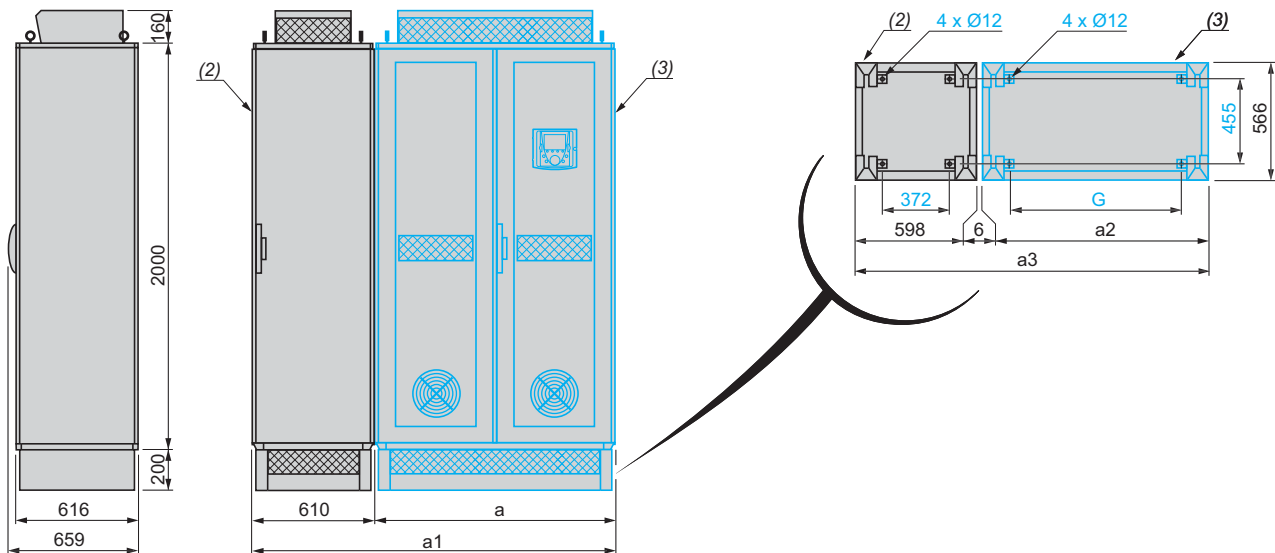

**Note:** The VW3 A9 549 enclosure must be mounted on the left of the VW3 A9 547 and VW3 A9 548 pre-equipped IP 54 enclosure kits

VW3	a	a1	a2	a3	G
A9 549 + A9 547	1010	1620	998	1602	772
A9 549 + A9 548	1210	1820	1198	1802	972

(1) For detail of location of terminals, see pages 42 and 43.

(2) IP 54 pre-equipped enclosure kit **VW3 A9 549**

(3) IP 54 pre-equipped enclosure kits **VW3 A9 547** and **VW3 A9 548**

**VW3 A9 550, 551**

Assembled kit

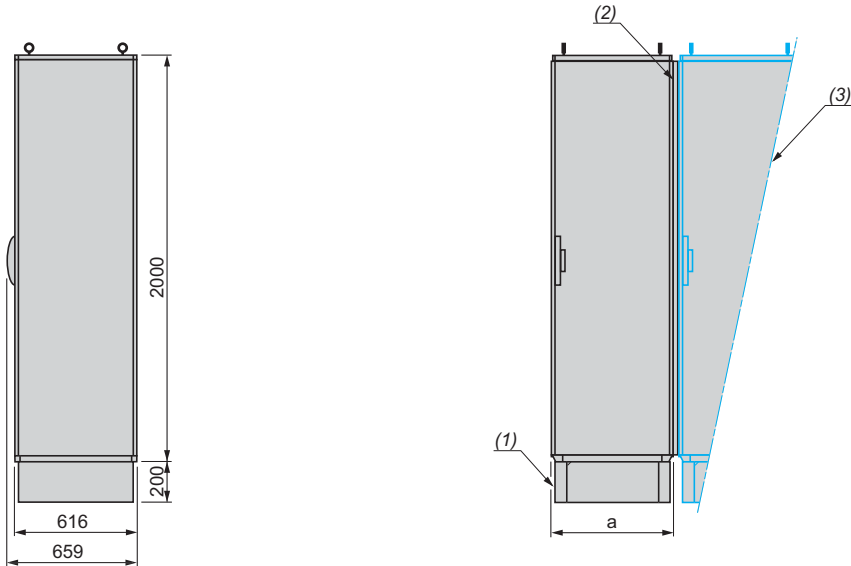

**Note:** The VW3 A9 550 and VW3 A9 551 empty enclosures must be mounted on the left of the VW3 A9 541...549 pre-equipped IP 54 enclosure kits

VW3	a
A9 550	610
A9 551	810

- (1) Plinth
- (2) Seal. For each empty enclosure added, allow for a spacing of 4 mm due to the seal.
- (3) IP 54 pre-equipped enclosure kits **VW3 A9 541...549**

#### Detail of location of terminals

VW3 A9 541...VW3 A9 544

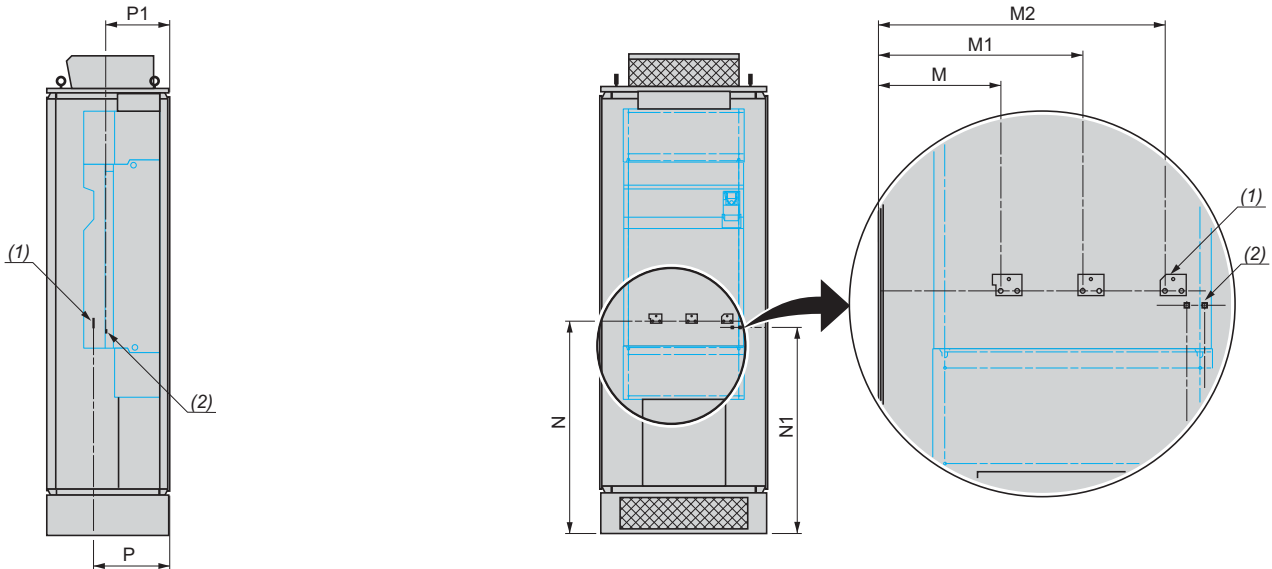

VW3	M	M1	M2	N	N1	P	P1
A9 541	240	300	360	1235	1200	355	285
A9 542	215	275	335	1335	1270	385	320
A9 543	225	300	375	1060	1025	380	320
A9 544	205	310	415	1065	1030	380	320

VW3 A9 545, 546

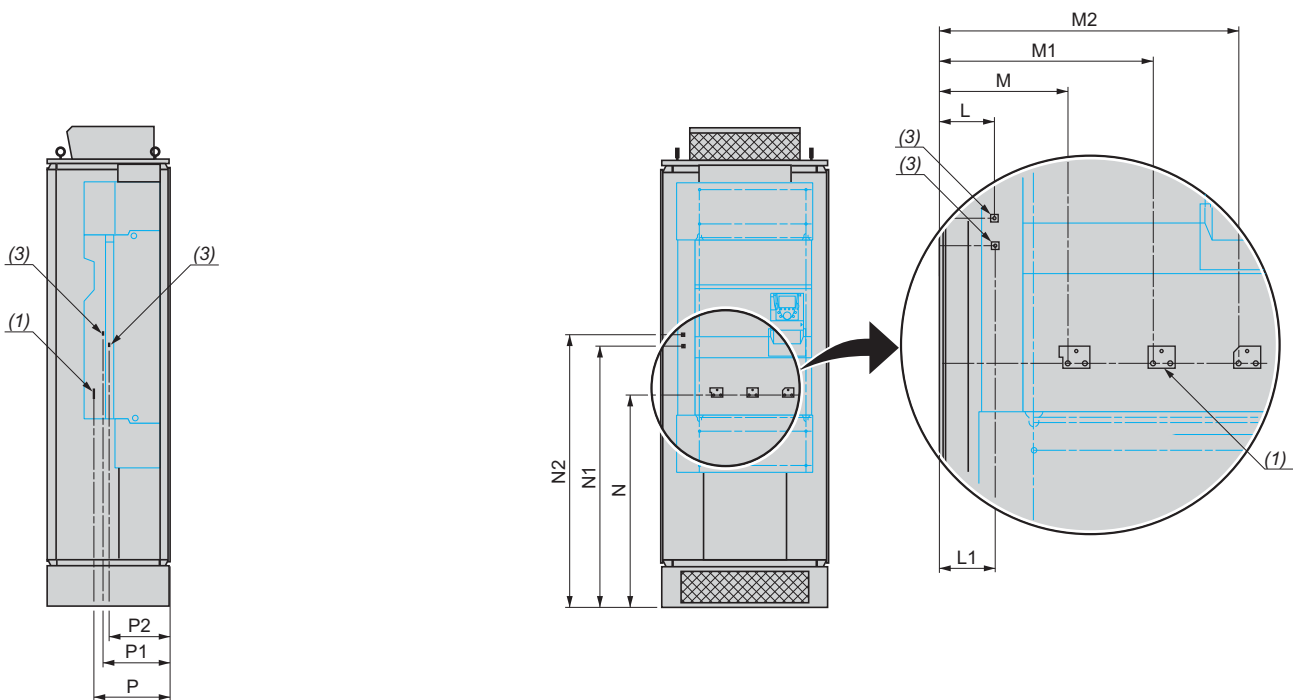

VW3	L	L1	M	M1	M2	N	N1	N2	P	P1	P2
A9 545	–	–	275	450	625	1055	–	–	380	–	–
A9 546	125	127	275	450	625	1055	1295	1355	380	335	305

(1) Terminals for connecting the motor.

(2) Terminals for connecting the braking transistor.

(3) Terminals for connecting the braking unit VW3 A7 101.

#### Detail of location of terminals (continued)

VW3 A9 547, 548

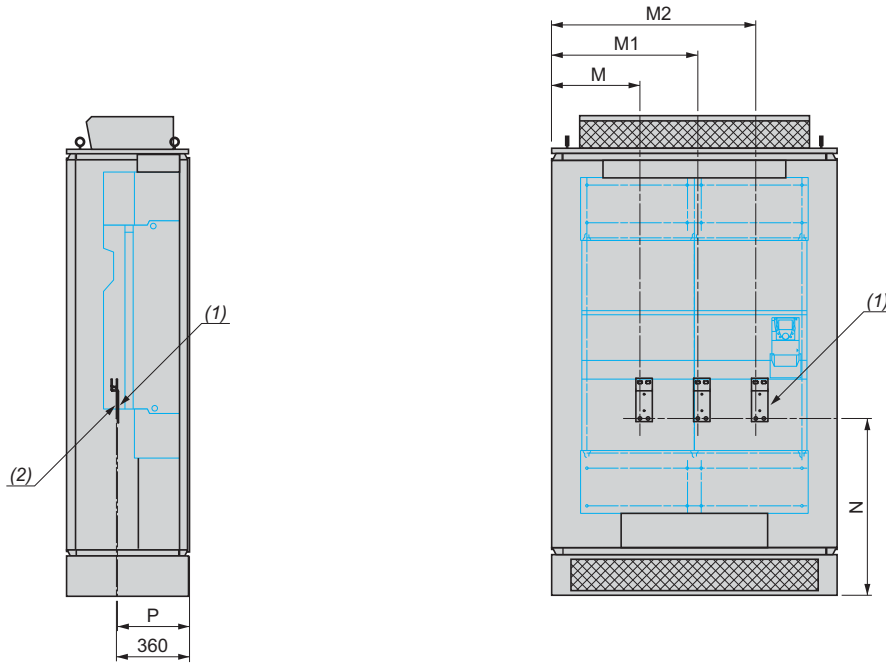

VW3	M1	M2	M3	N	P
A9 547	235	330	425	860	360
A9 548	255	350	445	870	360

(1) Terminals for connecting the motor.

(2) Terminals for connecting the braking unit VW3 A7 102.

#### Detail of location of terminals (continued)

VW3 A9 549

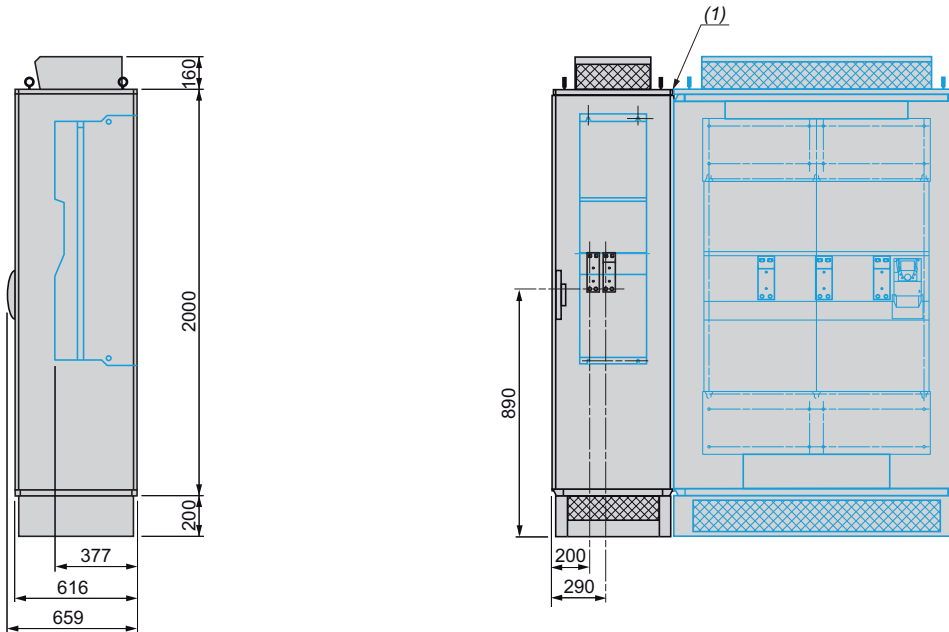

**Note:** The VW3 A9 550 and VW3 A9 551 empty enclosures must be mounted on the left of the VW3 A9 547 and VW3 A9 548 pre-equipped IP 54 enclosure kits (1) Seal. For each empty enclosure added, allow for a spacing of 4 mm due to the seal.

# Variable speed drives

## Altivar 61

IP 23 or IP 54 floor-standing enclosure compact version

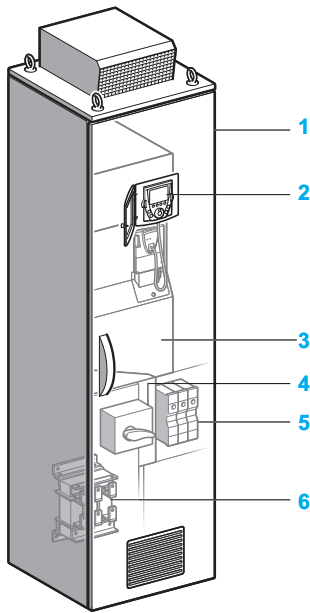

### Presentation

Altivar 61 variable speed drives can be supplied ready-assembled in an IP 23 or IP 54 floor-standing enclosure to facilitate installation and setup and, in particular, to ensure optimum ventilation.

The ATV 61EXC..... offer consists of a compact floor-standing enclosure providing IP 23 or IP 54 protection with common cooling circuit for industrial environments and infrastructures (tunnels, subways, smoke extraction and pumping, etc.).

The floor-standing enclosure is supplied ready to connect.

The ATV 61EXC..... offer covers motor power ratings from 90 kW to 800 kW with three types of power supply:

- 380...415 V three-phase, 90 kW to 630 kW (**ATV 61EXC.....N4**)
- 500 V three-phase, 90 kW to 630 kW (**ATV 61EXC.....N**)
- 600...690 V three-phase, 110 kW to 800 kW (**ATV 61EXC.....Y**)

The ATV 61EXC..... offer includes the choice of:

- A standard compact offer
- A modular offer in which a wide selection of options can be incorporated according to the rating of the drive

### The standard compact offer

This consists of:

- A wired, ready-assembled Sarel "Spacial 6000" enclosure **1**
- An ATV 61HD90N4D...HC63N4D or ATV 61HC11Y...HC80Y drive on heatsink **3**
- An IP 65 remote mounting kit for graphic display terminal **2**
- A switch and fast-acting fuses **4**
- Motor terminals **5**
- A line choke **6**

See pages 50 and 51.

### Modular offer

This consists of:

- The standard compact offer
- One or more options (see pages 52 to 57)

As well as these specific options, all the options available for Altivar 61 drives can be used at the same rating with the enclosed drives offer (see pages 172, 173 and 176 to 179).

For any configuration other than those shown on pages 52 to 57, please consult your Regional Sales Office.

### Common options (modular offer only)

- Adaptor for 115 V ~ logic inputs
- Encoder interface cards
- I/O extension cards
- Multi-pump and "Controller Inside" programmable cards
- Modbus TCP, EtherNet/IP, Fipio, Modbus Plus, DeviceNet, INTERBUS, CC-Link, Modbus/Uni-Telway, PROFIBUS DP, LonWorks, METASYS N2, APOGEE FLN, and BACnet communication cards
- PT100 relays, PTC relays
- Motor heater
- Additional 24 V  $\overline{\text{---}}$  power supply
- Emergency stop button
- Enclosure lighting
- Key switch (Local/Remote)
- Power supply circuit for external fan

See pages 52 and 53.

### Options dependent on the drive rating (modular offer only)

- Braking unit
- Isolating handle for switch
- Circuit-breaker
- Line contactor
- Control transformer
- Ammeter
- Enclosure heater
- Motor choke
- Sinus filter
- Cable entry via the top
- Plinth

See pages 54 to 57.

### Ventilation

#### IP 23 compact version

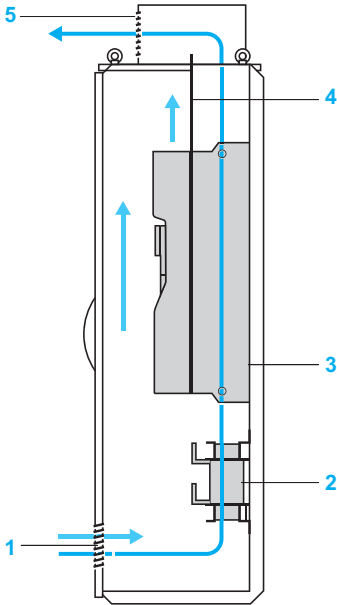

One common air circuit provides optimum enclosure ventilation, cooling the power section and the control section.

- 1 Air entry via an intake grille (without filter) on the enclosure door
- 2 Line choke
- 3 Fan integrated in the drive for ventilating the power section
- 4 Separating plate to prevent internal turbulence
- 5 Air outlet via a metal cover with protection against water splashes on the enclosure roof

#### IP 54 compact version

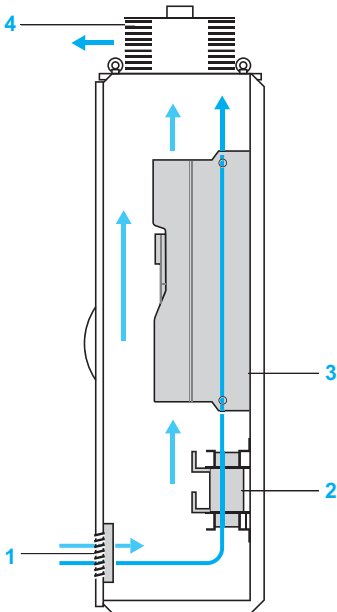

One common air circuit provides optimum enclosure ventilation, cooling the power section and the control section.

- 1 Air entry via an intake grille (with protective filter) on the enclosure door
- 2 Line choke
- 3 Fan integrated in the drive for ventilating the power section
- 4 Air outlet via a fan with filter on the enclosure roof



Specific characteristics				
Enclosure degree of protection	ATV 61EXC2●●●N4 ATV 61EXC2●●●N ATV 61EXC2●●●Y		IP 23: ■ Air intake via a grille on the enclosure door ■ Air outlet on the enclosure roof	
	ATV 61EXC5●●●N4 ATV 61EXC5●●●N ATV 61EXC5●●●Y		IP 54: ■ Air intake via a grille (with filter) on the enclosure door ■ Air outlet via a fan (with filter) on the enclosure roof	
Line supply connection			At the base of the switch	
Motor connection	ATV 61EXC●D90N4...C31N4 ATV 61EXC●D90N...C31N ATV 61EXC●C11Y...C40Y		On the terminals	
	ATV 61EXC●C40N4...C63N4		On the bars of the fan	
	ATV 61EXC●C40N...C63N ATV 61EXC●C50Y...C80Y		On additional bars	
Control terminal connection			Directly on the drive or on option terminals	
Colour of SAREL Spacial 6000 enclosures			RAL 7032 floor-standing enclosure	
Environmental characteristics (1)				
Maximum ambient pollution Definition of insulation			Degree 2 conforming to IEC/EN 61800-5-1	
Vibration resistance			Conforming to standard IEC/EN 60068-2-6 1.5 mm peak to peak from 3 to 10 Hz, 0.6 g from 10 to 200 Hz (3M3 according to IEC/EN 60721-3-3)	
Shock resistance			Conforming to standard IEC/EN 60068-2-7 4 g for 11 ms (3M2 according to IEC/EN 60721-3-3)	
Ambient air temperature	Operation	°C	Incoming air temperature 0...+40 (-10...+40 with enclosure heater) Up to +50°C with derating; IEC/EN 60721-3-3 class 3K3	
	Storage	°C	-25...+70	
	Control		Internal temperature monitored by a thermostat which can shut down the equipment	
Environmental conditions Use			IEC/EN 60721-3-3 classes 3C2, 3S2 and 3K3, without condensation	
Maximum relative humidity			95%	
Volume of cooling air	ATV 61EXC●D90N4, C11N4	m³/h	400	
	ATV 61EXC●C13N4, C16N4 ATV 61EXC●D90N...C16N ATV 61EXC●C11Y...C20Y	m³/h	600	
	ATV 61EXC●C22N4	m³/h	800	
	ATV 61EXC●C25N, C31N4 ATV 61EXC●C20N...C31N ATV 61EXC●C25Y...C40Y	m³/h	1200	
	ATV 61EXC●C40N4, C50N4	m³/h	1800	
	ATV 61EXC●C63N4 ATV 61EXC●C40N...C63N ATV 61EXC●C50Y...C80Y	m³/h	2400	
Electrical power characteristics (1)				
Power supply	Voltage	V	380 V – 15%...415 V +10% for ATV 61EXC●●●●N4 500 V – 15% for ATV 61EXC●●●●N 600...690 V +10% for ATV 61EXC●●●●Y	
	Frequency	Hz	50/60 Hz ± 5%	
Overvoltage class			Class 3 according to EN 50178	
Noise level	ATV 61EXC2	D90N4...C22N4 D90N...C16N C11Y...C20Y	dBA	64
		C25N4...C50N4 C20N...C31N C25Y...C40Y	dBA	66
		C63N4 C40N...C63N C50Y...C80Y	dBA	69
	ATV 61EXC5	D90N4...C22N4 D90N...C16N C11Y...C20Y	dBA	65
		C25N4, C31N4 C20N...C31N C25Y...C40Y	dBA	68
		C40N4, C50N4	dBA	78
		C63N4 C40N...C63N C50Y...C80Y	dBA	79

(1) For other characteristics, see pages 10 to 17.

### Connection characteristics

Three-phase supply voltage 380...415 V 50/60 Hz

Drive terminals		Power supply Upstream fuse protection	L1/R, L2/S, L3/T		Fast- acting fuse	U/T1, V/T2, W/T3				Recom- mended cross- section for motor cables
			Maximum wire size on switch			Maximum wire size on terminals				
			Bar	Ter- minals		Without motor choke		With motor choke		
						Bar	Ter- minals	Bar	Ter- minals	
A	mm <sup>2</sup>	mm <sup>2</sup>	A	mm <sup>2</sup>	mm <sup>2</sup>	mm <sup>2</sup>	mm <sup>2</sup>	mm <sup>2</sup>		
Cable entry via the bottom	ATV 61EXC●D90N4	250	M10, 2 x 120	–	250	–	2 x 120	–	2 x 120	3 x 95
	ATV 61EXC●C11N4	315	M10, 2 x 120	–	315	–	2 x 120	–	2 x 120	3 x 120
	ATV 61EXC●C13N4	400	M10, 2 x 120	–	400	–	2 x 120	–	2 x 120	3 x 150
	ATV 61EXC●C16N4	400	M10, 2 x 150	–	400	–	2 x 120	–	2 x 120	2 (3 x 95)
	ATV 61EXC●C22N4	500	2 x M12, 4 x 240	–	500	–	2 x 185	–	2 x 185	2 (3 x 120)
	ATV 61EXC●C25N4	630	2 x M12, 4 x 240	–	630	–	4 x 120	–	4 x 120	2 (3 x 150)
	ATV 61EXC●C31N4	800	2 x M12, 4 x 240	–	700	–	4 x 120	–	4 x 120	3 (3 x 150)
	ATV 61EXC●C40N4	800	2 x M12, 4 x 240	–	800	2 x M12, 4 x 240	–	2 x M12, 4 x 240	–	3 (3 x 185)
	ATV 61EXC●C50N4	1000	2 x M12, 4 x 240	–	2 x 500	2 x M12, 4 x 240	–	2 x M12, 4 x 240	–	4 (3 x 185)
	ATV 61EXC●C63N4	1250	3 x M12, 6 x 240	–	2 x 630	3 x M12, 6 x 240	–	3 x M12, 6 x 240	–	5 (3 x 185)
Cable entry via the top	ATV 61EXC●D90N4	250	–	2 x 120	250	–	2 x 120	–	2 x 120	3 x 95
	ATV 61EXC●C11N4	315	–	2 x 120	315	–	2 x 120	–	2 x 120	3 x 120
	ATV 61EXC●C13N4	400	–	2 x 120	400	–	2 x 120	–	2 x 120	3 x 150
	ATV 61EXC●C16N4	400	–	2 x 120	400	–	2 x 120	–	2 x 120	2 (3 x 95)
	ATV 61EXC●C22N4	500	–	2 x 185	500	–	2 x 185	–	2 x 185	2 (3 x 120)
	ATV 61EXC●C25N4	630	–	4 x 120	630	–	4 x 120	–	4 x 120	2 (3 x 150)
	ATV 61EXC●C31N4	800	–	4 x 120	700	–	4 x 120	–	4 x 120	3 (3 x 150)
	ATV 61EXC●C40N4	800	2 x M12, 4 x 240	–	800	2 x M12, 4 x 240	–	2 x M12, 4 x 240	–	3 (3 x 185)
	ATV 61EXC●C50N4	1000	2 x M12, 4 x 240	–	2 x 500	2 x M12, 4 x 240	–	2 x M12, 4 x 240	–	4 (3 x 185)
	ATV 61EXC●C63N4	1250	3 x M12, 6 x 240	–	2 x 630	3 x M12, 6 x 240	–	3 x M12, 6 x 240	–	5 (3 x 185)

### Connection characteristics (continued)

Three-phase supply voltage 500 V 50/60 Hz

Drive terminals		Power supply Upstream fuse protection	L1/R, L2/S, L3/T			U/T1, V/T2, W/T3				Recom- mended cross- section for motor cables
			Maximum wire size on switch		Fast- acting fuse	Maximum wire size on terminals				
			Bar	Ter- minals		Without motor choke		With motor choke		
					mm <sup>2</sup>	mm <sup>2</sup>	Bar	Ter- minals	Bar	
Cable entry via the bottom	ATV 61EXC●D90N	160	M10, 2 x 120	–	160	–	2 x 185	–	2 x 185	3 x 70
	ATV 61EXC●C11N	200	M10, 2 x 120	–	200	–	2 x 185	–	2 x 185	3 x 70
	ATV 61EXC●C13N	250	M10, 2 x 120	–	250	–	2 x 185	–	2 x 185	3 x 95
	ATV 61EXC●C16N	315	M10, 2 x 120	–	315	–	2 x 185	–	2 x 185	3 x 120
	ATV 61EXC●C20N	400	2 x M12, 4 x 240	–	400	–	4 x 120	–	4 x 120	3 x 185
	ATV 61EXC●C25N	500	2 x M12, 4 x 240	–	500	–	4 x 120	–	4 x 120	2 (3 x 120)
	ATV 61EXC●C31N	630	2 x M12, 4 x 240	–	630	–	4 x 120	–	4 x 120	3 (3 x 150)
	ATV 61EXC●C40N	800	3 x M12, 6 x 240	–	2 x 400	3 x M12, 6 x 240	–	4 x M12, 6 x 240	–	3 (3 x 150)
	ATV 61EXC●C50N	1000	3 x M12, 6 x 240	–	2 x 500	3 x M12, 6 x 240	–	4 x M12, 6 x 240	–	3 (3 x 185)
	ATV 61EXC●C63N	1250	3 x M12, 6 x 240	–	2 x 630	3 x M12, 6 x 240	–	4 x M12, 6 x 240	–	4 (3 x 185)
Cable entry via the top	ATV 61EXC●D90N	160	–	2 x 185	160	–	2 x 185	–	2 x 185	3 x 70
	ATV 61EXC●C11N	200	–	2 x 185	200	–	2 x 185	–	2 x 185	3 x 70
	ATV 61EXC●C13N	250	–	2 x 185	250	–	2 x 185	–	2 x 185	3 x 95
	ATV 61EXC●C16N	315	–	2 x 185	315	–	2 x 185	–	2 x 185	3 x 120
	ATV 61EXC●C20N	400	4 x M12, 6 x 240	–	400	4 x M12, 6 x 240	–	4 x M12, 6 x 240	–	3 x 185
	ATV 61EXC●C25N	500	4 x M12, 6 x 240	–	500	4 x M12, 6 x 240	–	4 x M12, 6 x 240	–	2 (3 x 120)
	ATV 61EXC●C31N	630	4 x M12, 6 x 240	–	630	4 x M12, 6 x 240	–	4 x M12, 6 x 240	–	2 (3 x 150)
	ATV 61EXC●C40N	800	4 x M12, 6 x 240	–	2 x 400	4 x M12, 6 x 240	–	4 x M12, 6 x 240	–	3 (3 x 150)
	ATV 61EXC●C50N	1000	4 x M12, 6 x 240	–	2 x 500	4 x M12, 6 x 240	–	4 x M12, 6 x 240	–	3 (3 x 185)
	ATV 61EXC●C63N	1250	4 x M12, 6 x 240	–	2 x 630	4 x M12, 6 x 240	–	4 x M12, 6 x 240	–	4 (3 x 185)

### Connection characteristics (continued)

Three-phase supply voltage 600...690 V 50/60 Hz

Drive terminals		Power supply Upstream fuse protection	L1/R, L2/S, L3/T			U/T1, V/T2, W/T3				Recom- mended cross- section for motor cables
			Maximum wire size on switch		Fast- acting fuse	Maximum wire size on terminals				
			Bar	Ter- minals		Without motor choke		With motor choke		
					mm <sup>2</sup>	mm <sup>2</sup>	Bar	Ter- minals	Bar	
Cable entry via the bottom	ATV 61EXC●C11Y	160	M10, 2 x 120	–	160	–	2 x 185	–	2 x 185	3 x 70
	ATV 61EXC●C13Y	200	M10, 2 x 120	–	200	–	2 x 185	–	2 x 185	3 x 70
	ATV 61EXC●C16Y	250	M10, 2 x 120	–	250	–	2 x 185	–	2 x 185	3 x 95
	ATV 61EXC●C20Y	315	M10, 2 x 120	–	315	–	2 x 185	–	2 x 185	3 x 120
	ATV 61EXC●C25Y	400	2 x M12, 4 x 240	–	400	–	4 x 120	–	4 x 120	3 x 185
	ATV 61EXC●C31Y	500	2 x M12, 4 x 240	–	500	–	4 x 120	–	4 x 120	2 (3 x 120)
	ATV 61EXC●C40Y	630	2 x M12, 4 x 240	–	630	–	4 x 120	–	4 x 120	2 (3 x 150)
	ATV 61EXC●C50Y	800	3 x M12, 6 x 240	–	2 x 400	3 x M12, 6 x 240	–	4 x M12, 6 x 240	–	3 (3 x 150)
	ATV 61EXC●C63Y	1000	3 x M12, 6 x 240	–	2 x 500	3 x M12, 6 x 240	–	4 x M12, 6 x 240	–	3 (3 x 185)
	ATV 61EXC●C80Y	1250	3 x M12, 6 x 240	–	2 x 630	3 x M12, 6 x 240	–	4 x M12, 6 x 240	–	4 (3 x 185)
Cable entry via the top	ATV 61EXC●C11Y	160	–	2 x 185	160	–	2 x 185	–	2 x 185	3 x 70
	ATV 61EXC●C13Y	200	–	2 x 185	200	–	2 x 185	–	2 x 185	3 x 70
	ATV 61EXC●C16Y	250	–	2 x 185	250	–	2 x 185	–	2 x 185	3 x 95
	ATV 61EXC●C20Y	315	–	2 x 185	315	–	2 x 185	–	2 x 185	3 x 120
	ATV 61EXC●C25Y	400	4 x M12, 6 x 240	–	400	4 x M12, 6 x 240	–	4 x M12, 6 x 240	–	3 x 185
	ATV 61EXC●C31Y	500	4 x M12, 6 x 240	–	500	4 x M12, 6 x 240	–	4 x M12, 6 x 240	–	2 (3 x 120)
	ATV 61EXC●C40Y	630	4 x M12, 6 x 240	–	630	4 x M12, 6 x 240	–	4 x M12, 6 x 240	–	2 (3 x 150)
	ATV 61EXC●C50Y	800	4 x M12, 6 x 240	–	2 x 400	4 x M12, 6 x 240	–	4 x M12, 6 x 240	–	3 (3 x 150)
	ATV 61EXC●C63Y	1000	4 x M12, 6 x 240	–	2 x 500	4 x M12, 6 x 240	–	4 x M12, 6 x 240	–	3 (3 x 185)
	ATV 61EXC●C80Y	1250	4 x M12, 6 x 240	–	2 x 630	4 x M12, 6 x 240	–	4 x M12, 6 x 240	–	4 (3 x 185)

# Variable speed drives

## Altivar 61

IP 23 or IP 54 floor-standing enclosure compact version

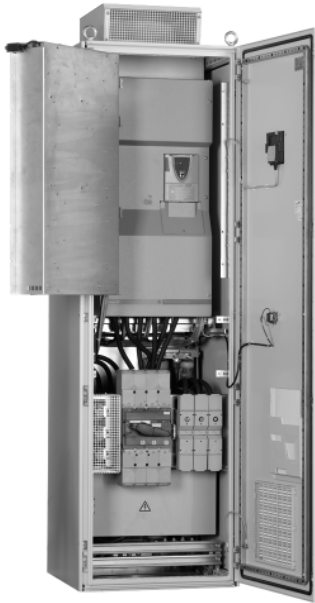

ATV 61EXC2D90N4

IP 23 or IP 54 floor-standing enclosure compact version				
Degree of protection	Line supply Max. prospective line Isc (1) kA	With drive	Reference	Weight kg
<b>Three-phase supply voltage 380...415 V 50/60 Hz</b>				
IP 23	100	ATV 61HD90N4D	<b>ATV 61EXC2D90N4</b>	315.000
		ATV 61HC11N4D	<b>ATV 61EXC2C11N4</b>	315.000
		ATV 61HC13N4D	<b>ATV 61EXC2C13N4</b>	335.000
		ATV 61HC16N4D	<b>ATV 61EXC2C16N4</b>	350.000
		ATV 61HC22N4D	<b>ATV 61EXC2C22N4</b>	380.000
		ATV 61HC25N4D	<b>ATV 61EXC2C25N4</b>	485.000
		ATV 61HC31N4D	<b>ATV 61EXC2C31N4</b>	485.000
		ATV 61HC40N4D	<b>ATV 61EXC2C40N4</b>	640.000
		ATV 61HC50N4D	<b>ATV 61EXC2C50N4</b>	680.000
		ATV 61HC63N4D	<b>ATV 61EXC2C63N4</b>	805.000
IP 54	100	ATV 61HD90N4D	<b>ATV 61EXC5D90N4</b>	325.000
		ATV 61HC11N4D	<b>ATV 61EXC5C11N4</b>	325.000
		ATV 61HC13N4D	<b>ATV 61EXC5C13N4</b>	345.000
		ATV 61HC16N4D	<b>ATV 61EXC5C16N4</b>	360.000
		ATV 61HC22N4D	<b>ATV 61EXC5C22N4</b>	385.000
		ATV 61HC25N4D	<b>ATV 61EXC5C25N4</b>	485.000
		ATV 61HC31N4D	<b>ATV 61EXC5C31N4</b>	485.000
		ATV 61HC40N4D	<b>ATV 61EXC5C40N4</b>	660.000
		ATV 61HC50N4D	<b>ATV 61EXC5C50N4</b>	700.000
		ATV 61HC63N4D	<b>ATV 61EXC5C63N4</b>	835.000
<b>Three-phase supply voltage 500 V 50/60 Hz</b>				
IP 23	100	ATV 61HC11Y	<b>ATV 61EXC2D90N</b>	361.000
		ATV 61HC13Y	<b>ATV 61EXC2C11N</b>	361.000
		ATV 61HC16Y	<b>ATV 61EXC2C13N</b>	412.000
		ATV 61HC20Y	<b>ATV 61EXC2C16N</b>	412.000
		ATV 61HC25Y	<b>ATV 61EXC2C20N</b>	503.000
		ATV 61HC31Y	<b>ATV 61EXC2C25N</b>	553.000
		ATV 61HC40Y	<b>ATV 61EXC2C31N</b>	553.000
		ATV 61HC50Y	<b>ATV 61EXC2C40N</b>	828.000
		ATV 61HC63Y	<b>ATV 61EXC2C50N</b>	916.000
		ATV 61HC80Y	<b>ATV 61EXC2C63N</b>	916.000
IP 54	100	ATV 61HC11Y	<b>ATV 61EXC5D90N</b>	371.000
		ATV 61HC13Y	<b>ATV 61EXC5C11N</b>	371.000
		ATV 61HC16Y	<b>ATV 61EXC5C13N</b>	422.000
		ATV 61HC20Y	<b>ATV 61EXC5C16N</b>	422.000
		ATV 61HC25Y	<b>ATV 61EXC5C20N</b>	503.000
		ATV 61HC31Y	<b>ATV 61EXC5C25N</b>	553.000
		ATV 61HC40Y	<b>ATV 61EXC5C31N</b>	553.000
		ATV 61HC50Y	<b>ATV 61EXC5C40N</b>	858.000
		ATV 61HC63Y	<b>ATV 61EXC5C50N</b>	946.000
		ATV 61HC80Y	<b>ATV 61EXC5C63N</b>	946.000

(1) These values are given for use with upstream fuses (see pages 47 to 49).

## Variable speed drives

## Altivar 61

IP 23 or IP 54 floor-standing enclosure compact version

IP 23 or IP 54 floor-standing enclosure compact version  
(continued)

Degree of protection	Line supply Max. prospective line I <sub>sc</sub> (1) kA	With drive	Reference	Weight kg
<b>Three-phase supply voltage 600...690 V 50/60 Hz</b>				
IP 23	100	ATV 61HC11Y	ATV 61EXC2C11Y	361.000
		ATV 61HC13Y	ATV 61EXC2C13Y	361.000
		ATV 61HC16Y	ATV 61EXC2C16Y	412.000
		ATV 61HC20Y	ATV 61EXC2C20Y	412.000
		ATV 61HC25Y	ATV 61EXC2C25Y	503.000
		ATV 61HC31Y	ATV 61EXC2C31Y	553.000
		ATV 61HC40Y	ATV 61EXC2C40Y	553.000
		ATV 61HC50Y	ATV 61EXC2C50Y	828.000
		ATV 61HC63Y	ATV 61EXC2C63Y	916.000
ATV 61HC80Y	ATV 61EXC2C80Y	916.000		
IP 54	100	ATV 61HC11Y	ATV 61EXC5C11Y	371.000
		ATV 61HC13Y	ATV 61EXC5C13Y	371.000
		ATV 61HC16Y	ATV 61EXC5C16Y	422.000
		ATV 61HC20Y	ATV 61EXC5C20Y	422.000
		ATV 61HC25Y	ATV 61EXC5C25Y	503.000
		ATV 61HC31Y	ATV 61EXC5C31Y	553.000
		ATV 61HC40Y	ATV 61EXC5C40Y	553.000
		ATV 61HC50Y	ATV 61EXC5C50Y	858.000
		ATV 61HC63Y	ATV 61EXC5C63Y	946.000
ATV 61HC80Y	ATV 61EXC5C80Y	946.000		

(1) These values are given for use with upstream fuses (see pages 47 to 49).

## Variable speed drives

Altivar 61

IP 23 or IP 54 floor-standing enclosure compact version

Common options

Common options without modification of the enclosure <sup>(1)</sup>		
Description	Reference	Weight kg
Adaptor for 115 V ~ logic inputs	VW3 A3E 101 (2)	0.200
Encoder interface cards with RS 422, 5 V compatible differential outputs	VW3 A3E 401 (3)	0.200
Encoder interface card with 12 V open collector outputs	VW3 A3E 403 (3)	0.200
Encoder interface card with 15 V open collector outputs	VW3 A3E 404 (3)	0.200
Encoder interface card with 12 V push-pull outputs	VW3 A3E 405 (3)	0.200
Encoder interface card with 15 V push-pull outputs	VW3 A3E 406 (3)	0.200
Encoder interface card with 24 V push-pull outputs	VW3 A3E 407 (3)	0.200
Logic I/O extension card	VW3 A3E 201 (4)	0.320
Extended I/O extension card	VW3 A3E 202 (4)	0.300
Multi-pump card	VW3 A3E 502 (5) (6)	0.320
"Water solution" multi-pump card	VW3 A3E 503 (5) (6)	0.320
"Controller Inside" programmable card	VW3 A3E 501 (6) (7)	0.300
Modbus TCP communication card	VW3 A3E 310 (8)	0.300
EtherNet/IP communication card	VW3 A3E 316 (8)	0.300
Fipio communication card	VW3 A3E 311 (8)	0.300
Modbus Plus communication card	VW3 A3E 302 (8)	0.300
DeviceNet communication card	VW3 A3E 309 (8)	0.300
INTERBUS communication card	VW3 A3E 304 (8)	0.300
CC-Link communication card	VW3 A3E 317 (8)	0.300
Modbus/Uni-Telway communication card	VW3 A3E 303 (8)	0.300
PROFIBUS DP communication card	VW3 A3E 307 (8)	0.300
LonWorks communication card	VW3 A3E 312 (8)	0.300
METASYS N2 communication card	VW3 A3E 313 (8)	0.300
APOGEE FLN communication card	VW3 A3E 314 (8)	0.300
BACnet communication card	VW3 A3E 315 (8)	0.300

(1) For any other configuration, please consult your Regional Sales Office.

(2) The technical characteristics of the VW3 A3E 101 adaptor are identical to those of the VW3 A3 101 adaptor (see page 26).

(3) The technical characteristics of the VW3 A3E 401 and 403...407 encoder interface cards are identical to those of the VW3 A3 401 and 403...407 encoder interface cards (see pages 110 and 111).

(4) The technical characteristics of the VW3 A3E 201 and VW3 A3E 202 I/O extension cards are identical to those of the VW3 A3 201 and VW3 A3 202 I/O extension cards (see pages 112 and 113).

(5) The technical characteristics of the VW3 A3E 502 and VW3 A3E 503 multi-pump cards are identical to those of the VW3 A3 502 and VW3 A3 503 multi-pump cards (see page 117).

(6) If the power consumption does not exceed 200 mA, this card can be powered by the drive. For a power consumption in excess of 200 mA, the additional 24 V  $\overline{\text{---}}$  power supply option, reference VW3 AE 1401, should be ordered separately (see page 53).

(7) The technical characteristics of the VW3 A3E 501 "Controller Inside" programmable card are identical to those of the VW3 A3 501 "Controller Inside" programmable card (see page 120).

(8) The technical characteristics of the VW3 A3E 302...304, 307 and 309...317 communication cards are identical to those of the VW3 A3 302...304, 307 and 309...317 communication cards (see pages 128 to 133).

## Variable speed drives

Altivar 61

IP 23 or IP 54 floor-standing enclosure compact version

Common options

Common options without modification of the enclosure (1)		
Description	Reference	Weight kg
Remote control terminals X12	VW3 AE 1201	0.700
Remote option card terminals X13 For I/O extension cards VW3 A3E 201 and 202	VW3 AE 1202 (2)	0.900
External 230 V ~ supply terminals	VW3 AE 1301	0.100
Additional 24 V DC power supply, nominal current 2 A (3)	VW3 AE 1401	2.200
External 24 V DC power terminals	VW3 AE 1402	0.100
Emergency stop button	VW3 AE 1501	0.100
"Preventa type AC" fault relay	VW3 AE 1502	0.100
"Preventa type ATE" fault relay	VW3 AE 1503	0.100
Enclosure lighting	VW3 AE 1601	1.500
Key switch (Local/Remote)	VW3 AE 1801	0.200
Additional electrical input isolation	VW3 AE 1901	0.100
Additional electrical output isolation	VW3 AE 1902	0.100
PTC relay	VW3 AE 2001	0.100
PTC relay with PTB (ATEX) certification (4)	VW3 AE 2002	0.100
PT100 relay for motor winding	VW3 AE 2003	0.300
PT100 relay for motor bearings	VW3 AE 2004	0.300
Motor heater 200 W, 230 V	VW3 AE 2101	0.200
Power supply circuit with 400 V protection for 1000 W external fan	VW3 AE 2102	0.200
Relay for logic output	VW3 AE 2201	0.100
Voltmeter 380...415 V three-phase supply voltage	VW3 AE 2301	0.400
Voltmeter 500 V three-phase supply voltage	VW3 AE 2302	0.400
Voltmeter 600...690 V three-phase supply voltage	VW3 AE 2303	0.400

(1) For any other configuration, please consult your Regional Sales Office.

(2) The X13 terminals, reference VW3 AE 1202, include the X12 terminals, reference VW3 AE 1201.

(3) Essential if the power consumption of the option cards exceeds 200 mA.

(4) ATEX: See pages 208 and 209.



## Variable speed drives

## Altivar 61

IP 23 or IP 54 floor-standing enclosure compact version

Options dependent on the drive rating

Options dependent on the drive rating (1)			
Three-phase supply voltage 380 V...415 V 50/60 Hz			
Description	For ATV 61 compact floor-standing enclosure	Reference (2)	Weight kg
Resistance braking unit	EXC●C25N4, C31N4	VW3 A7E 101 (3)	31.000
	EXC●C40N4...C63N4	VW3 AE 1003	190.000
Isolating handle for switch	EXC●D90N4...C13N4	VW3 AE 0103	1.000
	EXC●C16N4...C31N4	VW3 AE 0104	2.000
	EXC●C40N4...C63N4	VW3 AE 0105	2.000
Circuit-breaker (4)	EXC●D90N4...C13N4	VW3 AE 0106	–
	EXC●C16N4	VW3 AE 0107	1.400
	EXC●C22N4	VW3 AE 0108	1.400
	EXC●C25N4	VW3 AE 0109	1.400
	EXC●C31N4	VW3 AE 0110	9.400
	EXC●C40N4	VW3 AE 0111	–
	EXC●C50N4	VW3 AE 0112	–
	EXC●C63N4	VW3 AE 0113	–
Door handle for circuit-breaker	EXC●D90N4...C13N4	VW3 AE 0114	1.000
	EXC●C16N4...C25N4	VW3 AE 0115	2.000
	EXC●C31N4...C63N4	VW3 AE 0116	2.000
230 V undervoltage coil for circuit-breaker	EXC●D90N4...C25N4	VW3 AE 0117	0.500
	EXC●C31N4...C63N4	VW3 AE 0118	0.500
110 V undervoltage coil for circuit-breaker	EXC●D90N4...C25N4	VW3 AE 0119	0.500
	EXC●C31N4...C50N4	VW3 AE 0120	0.500
230 V motor for circuit-breaker	EXC●D90N4...C13N4	VW3 AE 0121	0.950
	EXC●C16N4	VW3 AE 0122	3.000
	EXC●C22N4, C25N4	VW3 AE 0123	3.000
	EXC●C31N4, C40N4	VW3 AE 0124	7.000
	EXC●C50N4	VW3 AE 0125	7.000
	EXC●C63N4	VW3 AE 0126	7.000
110 V motor for circuit-breaker	EXC●D90N4...C13N4	VW3 AE 0127	0.950
	EXC●C16N4	VW3 AE 0128	3.000
	EXC●C22N4, C25N4	VW3 AE 0129	3.000
	EXC●C31N4, C40N4	VW3 AE 0130	7.000
	EXC●C50N4	VW3 AE 0131	7.000
	EXC●C63N4	VW3 AE 0132	7.000
Line contactor	EXC●D90N4	VW3 AE 0206	7.000
	EXC●C11N4	VW3 AE 0207	7.000
	EXC●C13N4	VW3 AE 0218	10.000
	EXC●C16N4	VW3 AE 0208	11.000
	EXC●C22N4	VW3 AE 0209	12.000
	EXC●C25N4	VW3 AE 0210	14.000
	EXC●C31N4, C40N4	VW3 AE 0211	21.000
	EXC●C50N4	VW3 AE 0213	28.000
	EXC●C63N4	VW3 AE 0214	42.000

(1) For any other configuration, please consult your Regional Sales Office.

(2) The options depend on the rating of the drive and may lead to modification of the size of the enclosure.

(3) The technical characteristics of the VW3 A7E 101 braking units are identical to those of the VW3 A7 101 braking units (see page 136).

(4) The circuit-breaker replaces the switch in the standard compact offer.

## Variable speed drives

## Altivar 61

IP 23 or IP 54 floor-standing enclosure compact version

Options dependent on the drive rating

## Options dependent on the drive rating (continued) (1)

## Three-phase supply voltage 380...415 V 50/60 Hz (continued)

Description	For ATV 61 compact floor-standing enclosure	Reference (2)	Weight kg
500 VA ~ control transformer , 230 V ~ output	EXC●D90N4...C22N4	VW3 AE 0302	8.000
800 VA ~ control transformer , 230 V ~ output	EXC●C25N4...C63N4	VW3 AE 0303	11.000
Ammeter	EXC●D90N4...C13N4	VW3 AE 0405	0.200
	EXC●C16N4	VW3 AE 0406	0.200
	EXC●C22N4...C31N4	VW3 AE 0408	0.200
	EXC●C40N4	VW3 AE 0409	0.200
	EXC●C50N4	VW3 AE 0410	0.200
	EXC●C63N4	VW3 AE 0411	0.200
Enclosure heater	EXC●D90N4...C31N4	VW3 AE 0501	0.500
	EXC●C40N4...C63N4	VW3 AE 0502	1.000
Motor choke	EXC●D90N4	VW3 AE 0603	17.000
	EXC●C11N4, C13N4	VW3 AE 0604	35.000
	EXC●C16N4, C22N4	VW3 AE 0605	64.000
	EXC●C25N4, C31N4	VW3 AE 0606	102.000
	EXC2C40N4	VW3 AE 0608	222.000
	EXC5C40N4	VW3 AE 0612	222.000
	EXC2C50N4	VW3 AE 0609	228.000
	EXC5C50N4	VW3 AE 0613	228.000
	EXC2C63N4	VW3 AE 0610	234.000
	EXC5C63N4	VW3 AE 0614	234.000
Sinus filter (3)	EXC2D90N4, C11N4	VW3 AE 0641	318.000
	EXC5D90N4, C11N4	VW3 AE 0653	348.000
	EXC2C13N4	VW3 AE 0643	357.000
	EXC5C13N4	VW3 AE 0655	357.000
	EXC2C16N4	VW3 AE 0644	365.000
	EXC5C16N4	VW3 AE 0656	365.000
	EXC2C22N4	VW3 AE 0646	384.000
	EXC5C22N4	VW3 AE 0658	384.000
	EXC2C25N4, C31N4	VW3 AE 0648	434.000
	EXC5C25N4, C31N4	VW3 AE 0660	434.000
	EXC2C40N4	VW3 AE 0650	870.000
	EXC5C40N4	VW3 AE 0662	870.000
	EXC2C50N4	VW3 AE 0651	870.000
	EXC5C50N4	VW3 AE 0663	900.000
	EXC2C63N4	VW3 AE 0652	900.000
	EXC5C63N4	VW3 AE 0664	930.000

(1) For any other configuration, please consult your Regional Sales Office.

(2) The options depend on the rating of the drive and may lead to modification of the size of the enclosure.

(3) Option not compatible with the "Cable entry via the top" option.

## Variable speed drives

## Altivar 61

IP 23 or IP 54 floor-standing enclosure compact version

Options dependent on the drive rating

## Options dependent on the drive rating (continued) (1)

## Three-phase supply voltage 380...415 V 50/60 Hz (continued)

Description	Use	For ATV 61 compact floor-standing enclosure	Reference (2)	Weight kg	
Cable entry via the top (3)	Without motor choke	EXC●D90N4...C13N4	VW3 AE 0705	108.000	
		EXC●C16N4	VW3 AE 0706	108.000	
		EXC●C22N4	VW3 AE 0707	108.000	
		EXC●C25N4, C31N4	VW3 AE 0708	126.000	
		EXC●C40N4	VW3 AE 0709	216.000	
	With motor choke	EXC●C50N4	VW3 AE 0710	252.000	
		EXC●C63N4	VW3 AE 0711	252.000	
		EXC●C40N4	VW3 AE 0712	108.000	
		EXC●C50N4	VW3 AE 0713	126.000	
		EXC●C63N4	VW3 AE 0714	126.000	
200 mm plinth	With or without motor choke	EXC●D90N4...C22N4	VW3 AE 0801	17.000	
		EXC●C25N4, C31N4	VW3 AE 0802	20.000	
	Without motor choke	EXC●C40N4, C50N4	VW3 AE 0803	23.000	
		EXC●C63N4	VW3 AE 0804	24.000	
	With motor choke	EXC●C40N4, C50N4	VW3 AE 0805	38.000	
		EXC●C63N4	VW3 AE 0806	39.000	
	With braking unit	EXC●C40N4...C63N4	VW3 AE 0810	15.000	
	Plinth for cable entry via the top	With or without motor choke	EXC●D90N4...C31N4	VW3 AE 0807	15.000
		Without motor choke	EXC●C40N4...C63N4	VW3 AE 0808	30.000
		With motor choke	EXC●C40N4...C63N4	VW3 AE 0809	15.000
Plinth for sinus filter	–	EXC●D90N4...C31N4	VW3 AE 0816	17.000	
		EXC●C40N4...C63N4	VW3 AE 0817	20.000	

(1) For any other configuration, please consult your Regional Sales Office.

(2) The options depend on the rating of the drive and may lead to modification of the size of the enclosure.

(3) Option not compatible with the "Sinus filter" option.

## Variable speed drives

## Altivar 61

IP 23 or IP 54 floor-standing enclosure compact version

Options dependent on the drive rating

Options dependent on the drive rating (continued) (1)					
Three-phase supply voltage 500 V and 600...690 V 50/60 Hz (continued)					
Description	Use	For ATV 61 compact floor-standing enclosure		Reference (2)	Weight kg
		500 V	600...690 V		
Resistance braking unit	–	EXC●C20N...C31N	EXC●C25Y...C40Y	VW3 AE 1004	190.000
		EXC●C40N...C63N	EXC●C50Y...C80Y	VW3 AE 1005	190.000
Isolating handle for switch	–	EXC●D90N...C16N	EXC●C11Y...C20Y	VW3 AE 0103	1.000
		EXC●C20N...C31N	EXC●C25Y...C40Y	VW3 AE 0104	2.000
		EXC●C40N...C63N	EXC●C50Y...C80Y	VW3 AE 0105	2.000
Ammeter	–	–	EXC●C11Y	VW3 AE 0403	0.200
		EXC●D90N, C11N	EXC●C13Y, C16Y	VW3 AE 0404	0.200
		EXC●C13N, C16N	EXC●C20Y	VW3 AE 0405	0.200
		EXC●C20N	EXC●C25Y, C31Y	VW3 AE 0406	0.200
		EXC●C25N	EXC●C40Y	VW3 AE 0407	0.200
		EXC●C31N, C40N	EXC●C50Y, C63Y	VW3 AE 0408	0.200
		EXC●C50N	EXC●C80Y	VW3 AE 0409	0.200
		EXC●C63N	–	VW3 AE 0410	0.200
Enclosure heater	–	EXC●D90N...C31N	EXC●C11Y...C40Y	VW3 AE 0501	0.500
		EXC●C40N...C63N	EXC●C50Y...C80Y	VW3 AE 0502	1.000
Motor choke	–	EXC●D90N, C11N	EXC●C11Y, C13Y	VW3 AE 0603	17.000
		EXC●C13N, C16N	EXC●C16Y, C20Y	VW3 AE 0604	35.000
		EXC●C20N, C25N	EXC●C25Y, C31Y	VW3 AE 0605	64.000
		EXC●C31N	EXC●C40Y	VW3 AE 0606	102.000
		EXC2C40N	EXC2C50Y	VW3 AE 0626	192.000
		EXC5C40N	EXC5C50Y	VW3 AE 0628	192.000
		EXC2C50N, C63N	EXC2C63Y, C80Y	VW3 AE 0627	234.000
		EXC5C50N, C63N	EXC5C63Y, C80Y	VW3 AE 0629	234.000
Cable entry via the top	With or without motor choke	EXC●D90N...C16N	EXC●C11Y...C20Y	VW3 AE 0728	108.000
		EXC●C20N...C31N	EXC●C25Y...C40Y	VW3 AE 0729	126.000
	Without motor choke	EXC●C40N...C63N	EXC●C50Y...C80Y	VW3 AE 0730	252.000
		EXC●C40N...C63N	EXC●C50Y...C80Y	VW3 AE 0731	126.000
200 mm plinth	With or without motor choke	EXC●D90N...C16N	EXC●C11Y...C20Y	VW3 AE 0801	17.000
		EXC●C20N...C31N	EXC●C25Y...C40Y	VW3 AE 0802	20.000
		EXC●C40N...C63N	EXC●C50Y...C80Y	VW3 AE 0804	24.000
	With motor choke	EXC●C40N...C63N	EXC●C50Y...C80Y	VW3 AE 0806	39.000
	With braking unit	EXC●C20N...C63N	EXC●C25Y...C80Y	VW3 AE 0810	15.000
Plinth for cable entry via the top	With or without motor choke	EXC●D90N...C31N	EXC●C11Y...C40Y	VW3 AE 0807	15.000
		Without motor choke	EXC●C40N...C63N	EXC●C50Y...C80Y	VW3 AE 0808
	With motor choke	EXC●C40N...C63N	EXC●C50Y...C80Y	VW3 AE 0809	15.000

(1) For any other configuration, please consult your Regional Sales Office.

(2) The options depend on the rating of the drive and may lead to modification of the size of the enclosure.

#### IP 23 floor-standing enclosure compact version

ATV 61EXC2D90N4...EXC2C31N4, ATV 61EXC2D90N...EXC2C31N, ATV 61EXC2C11Y...EXC2C40Y

Common side view

Standard compact floor-standing enclosure

Standard compact floor-standing enclosure + additional floor-standing enclosures, according to the configuration

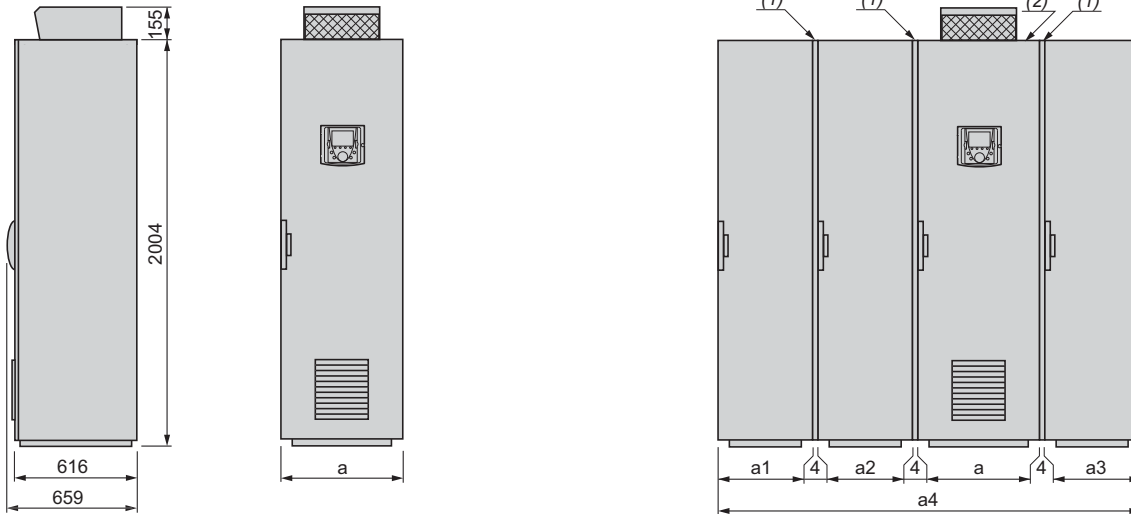

**Note:** Please respect the position of the enclosures during installation. The number of additional enclosures can vary according to the chosen configuration.

ATV 61 enclosures	Options	a	a1	a2	a3	a4
EXC2D90N4...EXC2C22N4	With or without common options or options (3) dependent on the drive rating	616	-	-	-	616
	Cable entry via the top option (4)	608	-	408	-	1020
	Sinus filter option	608	-	-	608	1220
EXC2C25N4...EXC2C31N4	With or without common options or options (6) dependent on the drive rating	816	-	-	-	816
	Cable entry via the top option (4)	808	-	408	-	1220
	Sinus filter option	808	-	-	608	1420
EXC2D90N...EXC2C16N, EXC2C11Y...EXC2C20Y	With or without common options or options dependent on the drive rating	616	-	-	-	616
	Cable entry via the top option	608	-	408	-	1020
EXC2C20N...EXC2C31N, EXC2C25Y...EXC2C40Y	With or without common options or options dependent on the drive rating	816	-	-	-	816
	Cable entry via the top option	808	-	408	-	1220
	Braking unit option	808	-	408	-	1220
	Braking unit + cable entry via the top options	808	408	400	-	1624

(1) Seal. For each additional floor-standing enclosure, allow a 4 mm space for the seal.

(2) Standard IP 23 compact version floor-standing enclosure.

(3) Except sinus filter option, which requires an additional enclosure. See table above. The sinus filter option is not compatible with the cable entry via the top option.

(4) The cable entry via the top option is not compatible with the sinus filter option.

**IP 23 floor-standing enclosure compact version (continued)**

ATV 61EXC2C40N4 ... EXC2C63N4, ATV 61EXC2C40N ... EXC2C63N, ATV 61EXC2C50Y...EXC2C80Y

Common side view

Standard compact floor-standing enclosure

Standard compact floor-standing enclosure + additional floor-standing enclosures, according to the configuration

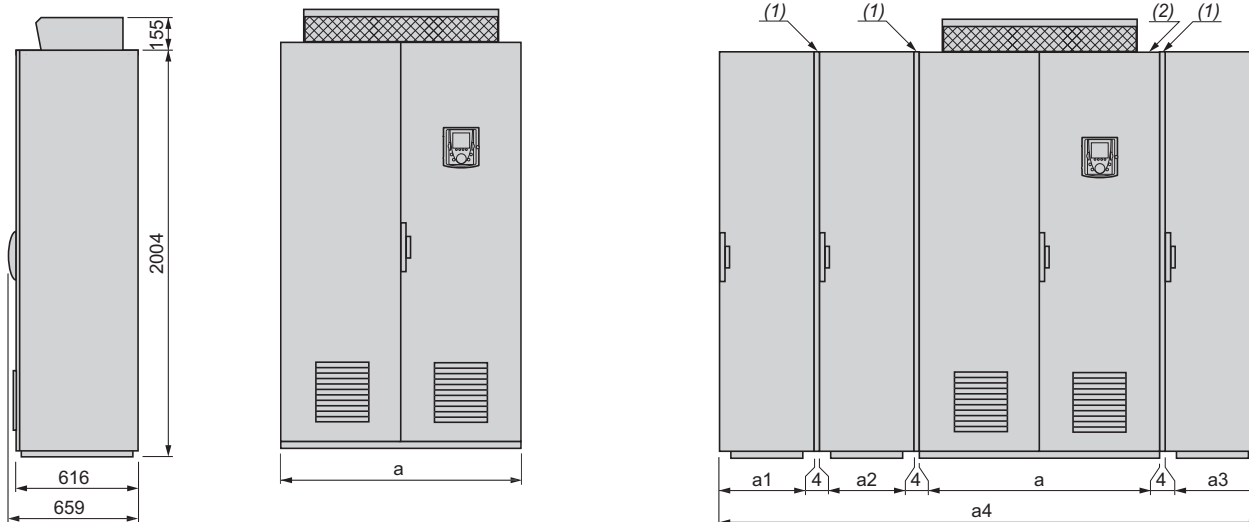

**Note:** Please respect the position of the enclosures during installation. The number of additional enclosures can vary according to the chosen configuration.

ATV 61 enclosures	Options	a	a1	a2	a3	a4
<b>EXC2C40N4, EXC2C50N4</b>	With or without common options or options (3) dependent on the drive rating	1016	–	–	–	1016
	Cable entry via the top option (4)	1000	–	408	408	1824
	Braking unit option only and/or options (3) dependent on rating	1008	–	408	–	1420
	Braking unit + cable entry via the top options (4)	1000	408	400	408	2228
	Motor choke option	1008	–	–	408	1420
	Sinus filter option	1008	–	–	808	1820
<b>EXC2C63N4</b>	With or without common options or options (3) dependent on the drive rating	1216	–	–	–	1216
	Cable entry via the top option (4)	1200	–	408	408	2024
	Braking unit option only and/or options (3) dependent on rating	1208	–	408	–	1620
	Braking unit + cable entry via the top options (4)	1200	408	400	408	2428
	Motor choke option	1208	–	–	408	1620
	Sinus filter option	1208	–	–	808	2020
<b>EXC2C40N...EXC2C63N, EXC2C50Y...EXC2C80Y</b>	With or without common options or options dependent on the drive rating	1216	–	–	–	1216
	Cable entry via the top option	1200	–	408	408	2024
	Braking unit option only and/or options dependent on rating	1208	–	408	–	1620
	Braking unit + cable entry via the top options	1200	408	400	408	2428
	Motor choke option	1208	–	–	408	1620

(1) Seal. For each additional floor-standing enclosure, allow a 4 mm space for the seal.

(2) Standard IP 23 compact version floor-standing enclosure.

(3) Except sinus filter option, which requires an additional enclosure. See table above. The sinus filter option is not compatible with the cable entry via the top option.

(4) The cable entry via the top option is not compatible with the sinus filter option.

# Variable speed drives

## Altivar 61

### IP 54 floor-standing enclosure compact version

#### IP 54 floor-standing enclosure compact version

ATV 61EXC5D90N4...EXC5C31N4, ATV 61EXC5D90N...EXC5C31N, ATV 61EXC5C11Y...EXC5C40Y

Common side view

Standard compact floor-standing enclosure

Standard compact floor-standing enclosure + additional floor-standing enclosures, according to the configuration

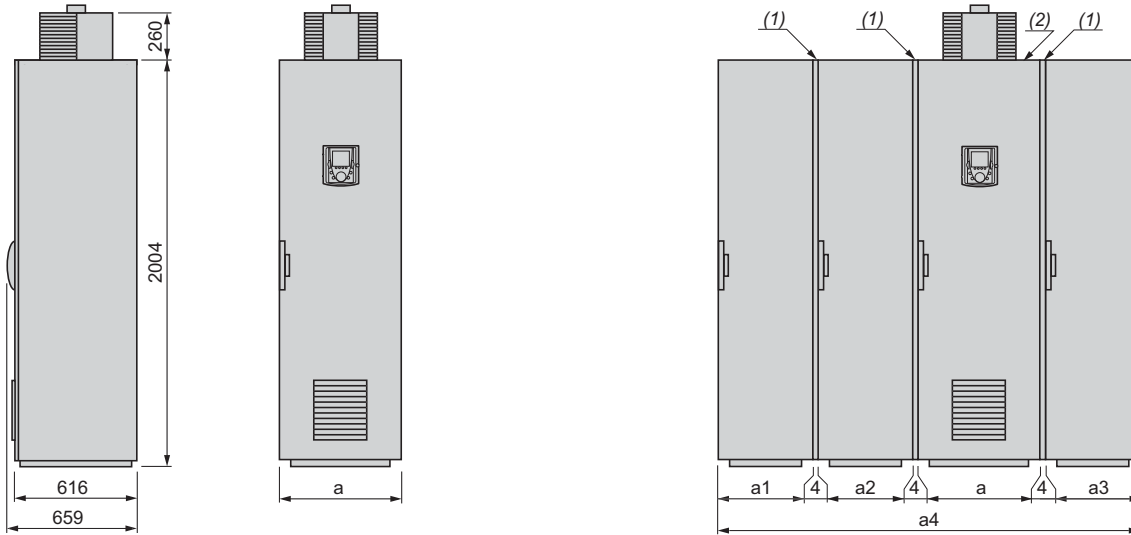

**Note:** Please respect the position of the enclosures during installation. The number of additional enclosures can vary according to the chosen configuration.

ATV 61 enclosures	Options	a	a1	a2	a3	a4
EXC5D90N4...EXC5C22N4	With or without common options or options (3) dependent on the drive rating	616	–	–	–	616
	Cable entry via the top option (4)	608	–	408	–	1020
	Sinus filter option	608	–	–	608	1220
EXC5C25N4...EXC5C31N4	With or without common options or options (3) dependent on the drive rating	816	–	–	–	816
	Cable entry via the top option (4)	808	–	408	–	1220
	Sinus filter option	808	–	–	608	1420
EXC5D90N...EXC5C16N, EXC5C11Y...EXC5C20Y	With or without common options or options dependent on the drive rating	616	–	–	–	616
	Cable entry via the top option	608	–	408	–	1020
EXC5C20N...EXC5C31N, EXC5C25Y...EXC5C40Y	With or without common options or options dependent on the drive rating	816	–	–	–	816
	Cable entry via the top option	808	–	408	–	1220
	Braking unit option	808	–	408	–	1220
	Braking unit + cable entry via the top options	808	408	400	–	1624

(1) Seal. For each additional floor-standing enclosure, allow a 4 mm space for the seal.

(2) Standard IP 54 compact version floor-standing enclosure.

(3) Except sinus filter option, which requires an additional enclosure. See table above. The sinus filter option is not compatible with the cable entry via the top option.

(4) The cable entry via the top option is not compatible with the sinus filter option.

**IP 54 floor-standing enclosure compact version (continued)**

ATV 61EXC5C40N4...EXC5C63N4, ATV 61EXC5C40N...EXC5C63N, ATV 61EXC5C50Y...EXC5C80Y

Common side view

Standard compact floor-standing enclosure

Standard compact floor-standing enclosure + additional floor-standing enclosures, according to the configuration

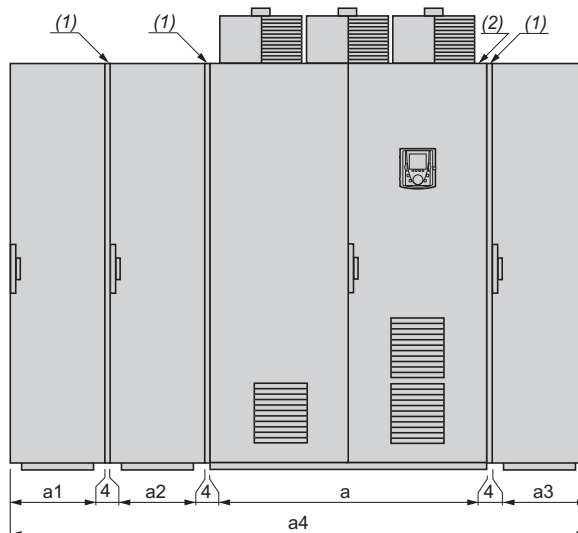
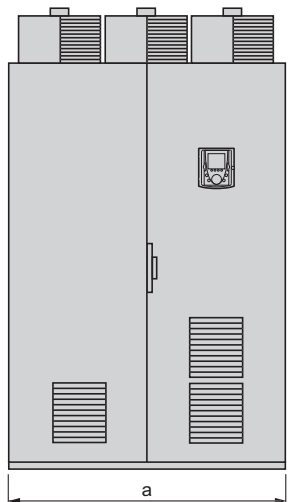
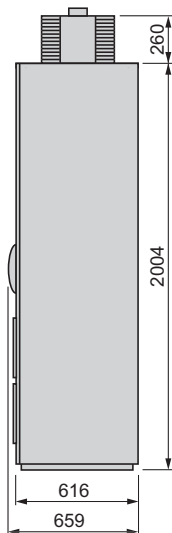

**Note:** Please respect the position of the enclosures during installation. The number of additional enclosures can vary according to the chosen configuration.

ATV 61 enclosures	Options	a	a1	a2	a3	a4
<b>EXC5C40N4, EXC5C50N4</b>	With or without common options or options (3) dependent on the drive rating	1016	–	–	–	1016
	Cable entry via the top option (4)	1000	–	408	408	1824
	Braking unit option only and/or options (3) dependent on rating	1008	–	408	–	1420
	Braking unit + cable entry via the top options (4)	1000	408	400	408	2228
	Motor choke option	1008	–	–	408	1420
	Sinus filter option	1008	–	–	808	1820
<b>EXC5C63N4</b>	With or without common options or options (3) dependent on the drive rating	1216	–	–	–	1216
	Cable entry via the top option (4)	1200	–	408	408	2024
	Braking unit option only and/or options (3) dependent on rating	1208	–	408	–	1620
	Braking unit + cable entry via the top options (4)	1200	408	400	408	2428
	Motor choke option	1208	–	–	408	1620
	Sinus filter option	1208	–	–	808	2020
<b>EXC5C40N...EXC5C63N, EXC5C50Y...EXC5C80Y</b>	With or without common options or options dependent on the drive rating	1216	–	–	–	1216
	Cable entry via the top option	1200	–	408	408	2024
	Braking unit option only and/or options dependent on rating	1208	–	408	–	1620
	Braking unit + cable entry via the top options	1200	408	400	408	2428
	Motor choke option	1208	–	–	408	1620

(1) Seal. For each additional floor-standing enclosure, allow a 4 mm space for the seal.

(2) Standard IP 54 compact version floor-standing enclosure.

(3) Except sinus filter option, which requires an additional enclosure. See table above. The sinus filter option is not compatible with the cable entry via the top option.

(4) The cable entry via the top option is not compatible with the sinus filter option.



### Installation recommendations

The derating curves for the drive nominal current ( $I_n$ ) are dependent on the temperature and switching frequency. For intermediate temperatures, interpolate between 2 curves.

**Note:** The drive will reduce the switching frequency automatically in the event of excessive temperature rise.

#### Derating curves for ATV 61EXC•D90N4...EXC•C63N4, ATV 61EXC•D90N...EXC•C20N, ATV 61EXC•C11Y...EXC•C25Y (1)

ATV 61EXC•D90N4... EXC•C63N4

ATV 61EXC•D90N, ATV 61EXC•C11Y

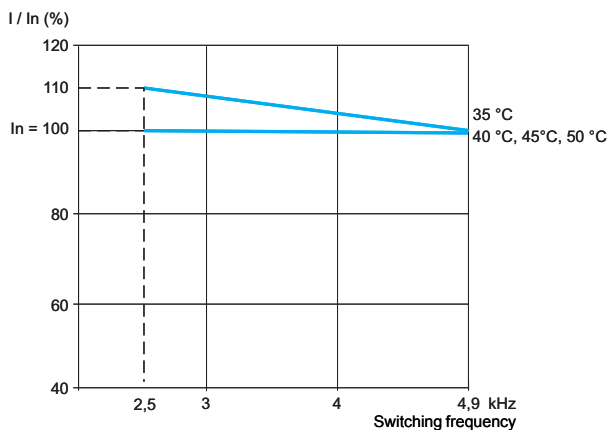
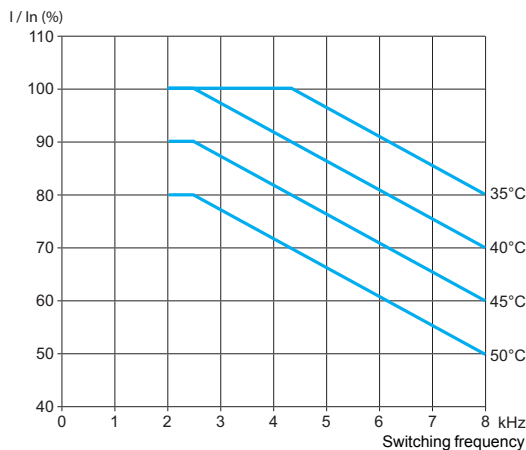

ATV 61EXC•C11N, ATV 61EXC•C13Y

ATV 61EXC•C13N, ATV 61EXC•C16Y

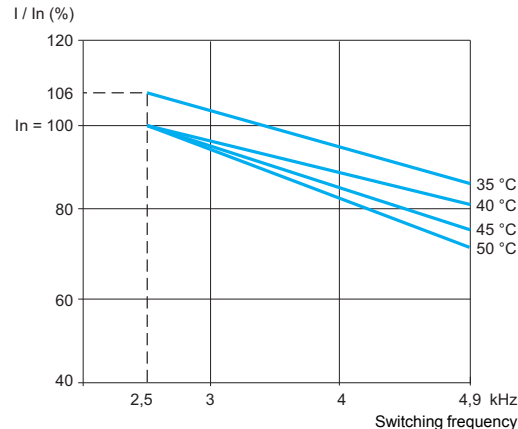
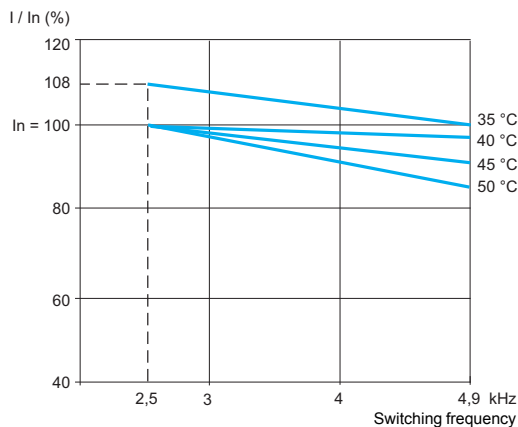

ATV 61EXC•C16N, ATV 61EXC•C20Y

ATV 61EXC•C20N, ATV 61EXC•C25Y

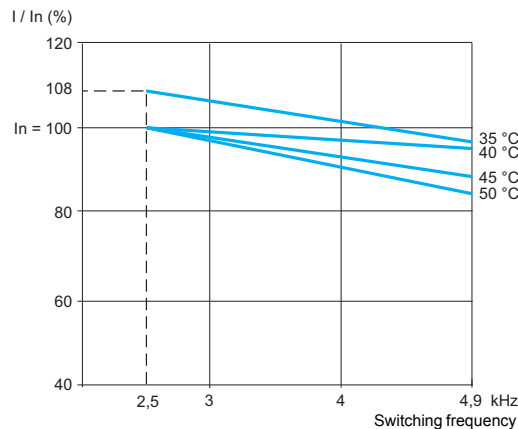
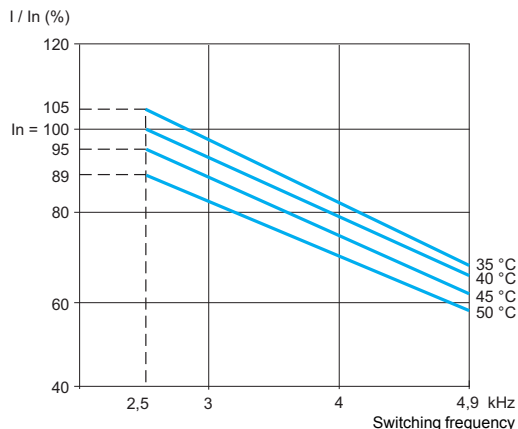

(1) The temperatures shown correspond to the temperature of the air entering the enclosure.

### Mounting recommendations (continued)

#### Derating curves for ATV 61EXC●C25N...EXC●C63N, ATV 61EXC●C31Y...EXC●C80Y (1)

##### ATV 61EXC●C25N, ATV 61EXC●C31Y

##### ATV 61EXC●C31N, ATV 61EXC●C40Y

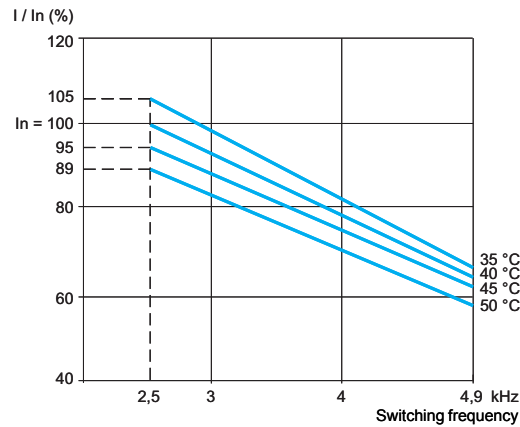
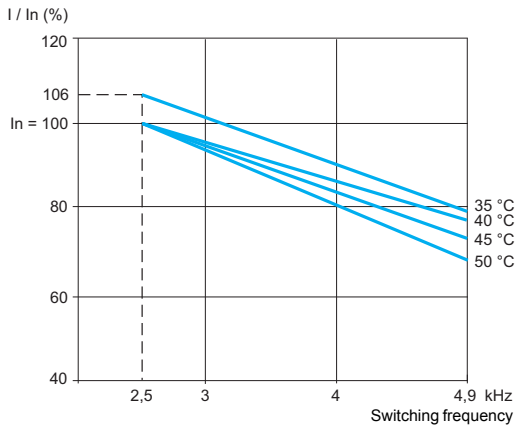

##### ATV 61EXC●C40N, ATV 61EXC●C50Y

##### ATV 61EXC●C50N, ATV 61EXC●C63Y

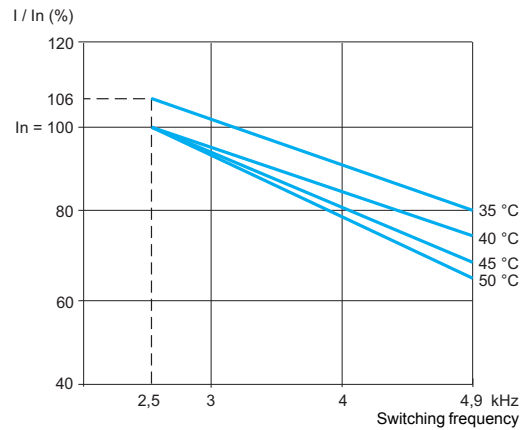
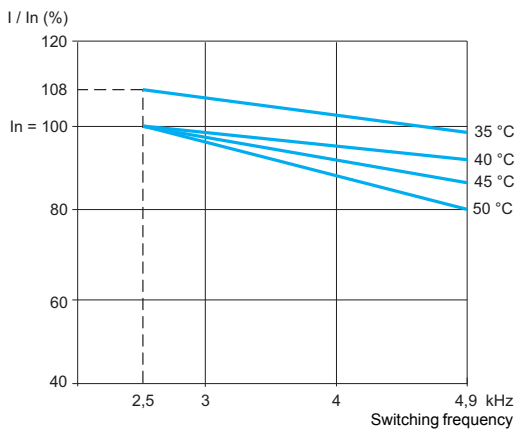

##### ATV 61EXC●C63N, ATV 61EXC●C80Y

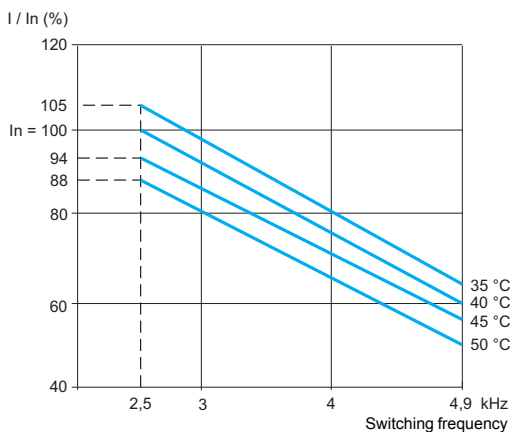

(1) The temperatures shown correspond to the temperature of the air entering the enclosure.

#### IP 23 or IP 54 floor-standing enclosure compact version

ATV 61EXC●D90N4...EXC●C40N4, ATV 61EXC●D90N...EXC●C31N, ATV 61EXC●C11Y...EXC●C40Y

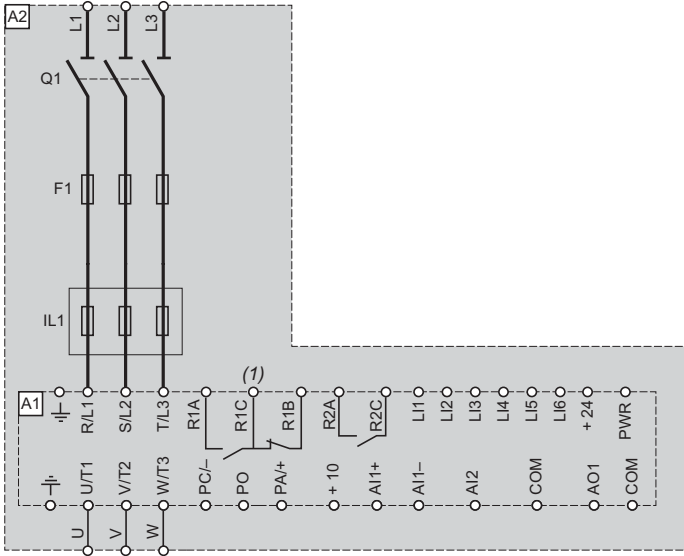

Ref.	Description
A1	ATV 61 drive (see pages 21 and 23)
A2	ATV 61EXC● compact floor-standing enclosure (see pages 50 and 51)
F1	Fast-acting fuse
IL1	Line choke
Q1	Switch

ATV 61EXC●C50N4, EXC●C63N4, ATV 61EXC●C40N...EXC●C63N, ATV 61EXC●C50Y...EXC●C80Y

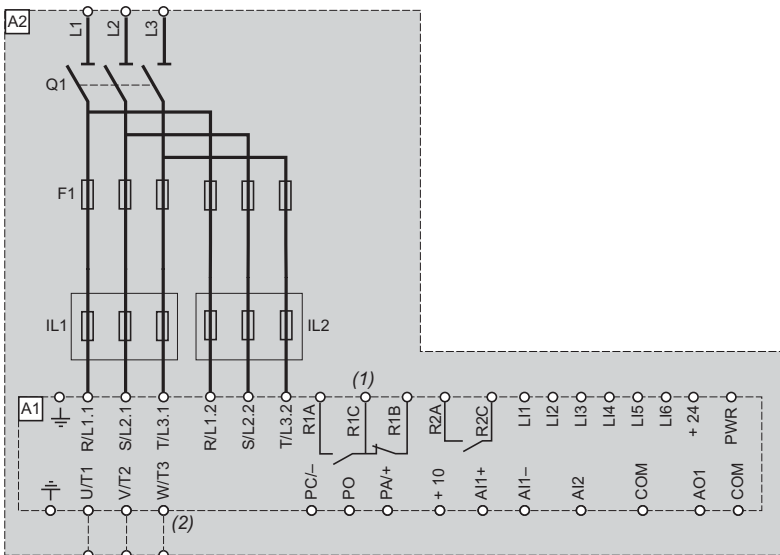

Ref.	Description
A1	ATV 61 drive (see pages 21 and 23)
A2	ATV 61EXC● compact floor-standing enclosure (see pages 50 and 51)
F1	Fast-acting fuse
IL1, IL2	Line chokes
Q1	Switch

(1) Fault relay contacts. For remote signalling of drive status.

(2) For ATV 61EXC●●●●N and ATV 61EXC●●●●Y only.

### Options common to all drives

#### Remote control terminals X12 - VW3 AE 1201

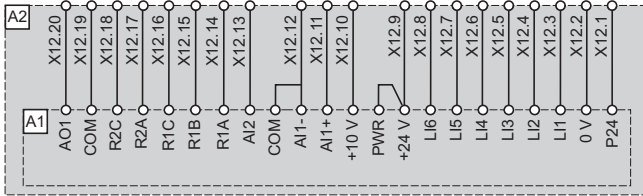

Ref.	Description
A1	ATV 61 drive (see pages 21 and 23)
A2	ATV 61EXC● compact floor-standing enclosure (see pages 50 and 51)

#### Remote option card terminals X13 - VW3 AE 1202

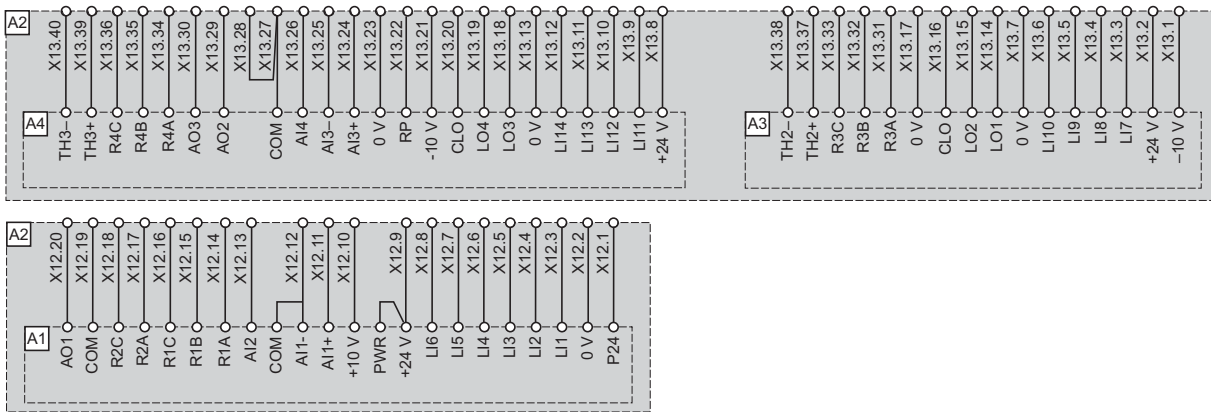

Ref.	Description
A1	ATV 61 drive (see pages 21 and 23)
A2	ATV 61EXC● compact floor-standing enclosure (see pages 50 and 51)
A3	I/O option card VW3 A3E 201 (see page 52)
A4	I/O option card VW3 A3E 202 (see page 52)

### Options common to all drives (continued)

#### External 230 V ~ supply terminals - VW3 AE 1301

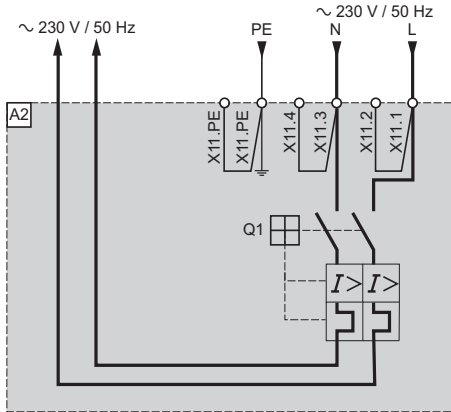

Ref.	Description
A2	ATV 61EXC compact floor-standing enclosure (see pages 50 and 51)
Q1	6 A circuit-breaker
X11	External 230 V ~ supply terminals

#### Additional 24 V DC supply terminals - VW3 AE 1401

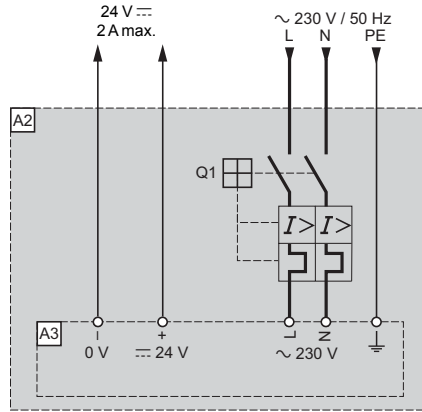

Ref.	Description
A2	ATV 61EXC compact floor-standing enclosure (see pages 50 and 51)
A3	Additional 24 V DC power supply
Q1	2 A circuit-breaker

#### External 24 V DC supply terminals - VW3 AE 1402

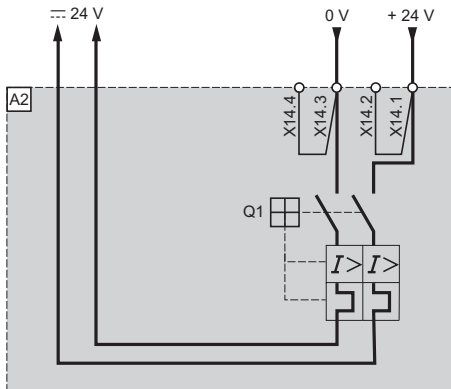

Ref.	Description
A2	ATV 61EXC compact floor-standing enclosure (see pages 50 and 51)
Q1	2 A circuit-breaker
X14	External 24 V DC supply terminals

### Options common to all drives (continued)

#### Emergency stop button - VW3 AE 1501

Scheme conforming to standards EN 954-1 category 1, IEC/EN 61508 capacity SIL1, stopping category 0 in accordance with IEC/EN 60204-1

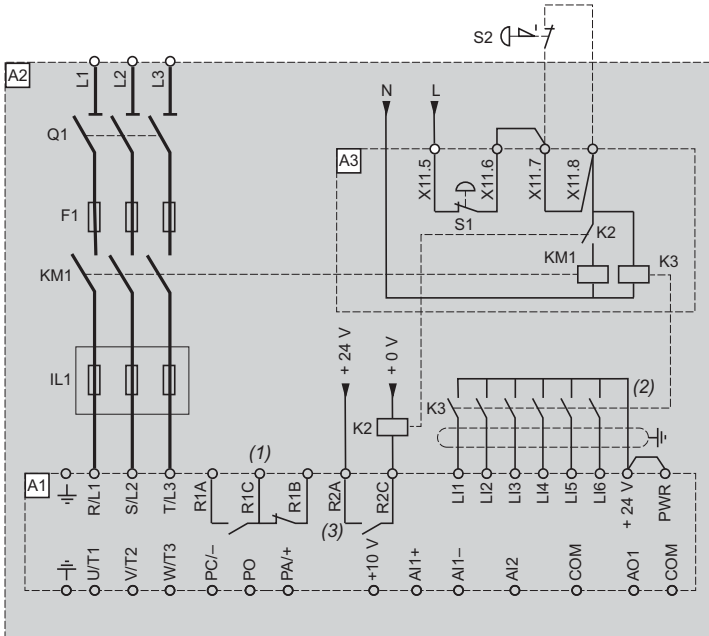

Ref.	Description
A1	ATV 61 drives (see pages 21 and 23)
A2	ATV 61EXC compact floor-standing enclosure (see pages 50 and 51)
A3	Emergency stop button
IL1	Line choke
K2	Line contactor control contactor
K3	Logic input control contactor
KM1	Line contactor
Q1	Switch
S1	Emergency stop button mounted on enclosure door
S2	Emergency stop button

(1) Fault relay contacts. For remote signalling of drive status.

(2) Connection of the common for the logic inputs depends on the position of switch SW1 (see schemes on page 214).

(3) Relay logic output R2A must be assigned to the "Line contactor" parameter.

#### Options common to all drives (continued)

#### “Preventa type AC” fault relay - VW3 AE 1502

Scheme conforming to standards EN 954-1 category 3, IEC/EN 61508 capacity SIL2, stopping category 0 in accordance with IEC/EN 60204-1

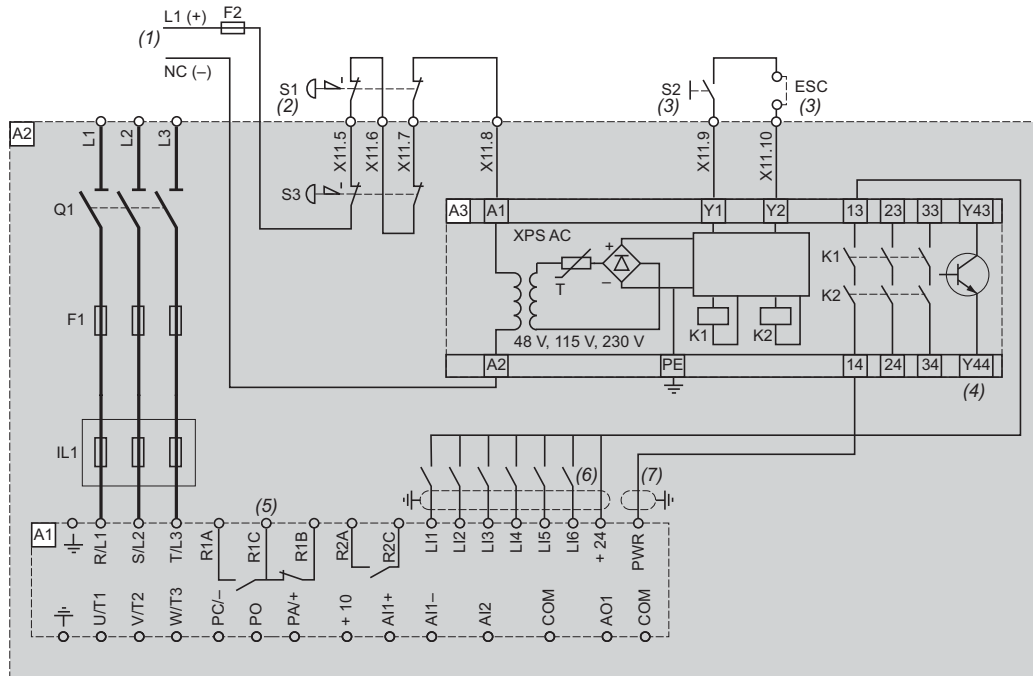

Ref.	Description
A1	ATV 61 drive (see pages 21 and 23)
A2	ATV 61EXC compact floor-standing enclosure (see pages 50 and 51)
A3	Preventa XPS AC safety module for monitoring emergency stops and switches. One safety module can manage the Power Removal function for several drives on the same machine. In this case, the PWR terminal on each drive must be connected to the + 24 V via the safety contacts on the XPS AC module. These contacts are independent for each drive.
F1	Fast-acting fuse
F2	Fuse
IL1	Line choke
Q1	Switch
S1	Emergency stop button with 2 contacts
S2	XB4 B or XB5 A pushbutton
S3	Emergency stop button with 2 contacts, mounted on enclosure door

(1) Power supply: 24 V $\overline{\text{---}}$ , 230 V $\sim$ .

(2) Requests freewheel stopping of the movement and activates the Power Removal safety function.

(3) S2: Resets the XPS AC module on power-up or after an emergency stop. ESC can be used to set external starting conditions.

(4) The logic output can be used to signal that the machine is in a safe stop state.

(5) Fault relay contacts. For remote signalling of drive status.

(6) Connection of the common for the logic inputs depends on the position of switch SW1 (see schemes on page 214).

(7) Standardized coaxial cable, type RG174/U according to MIL-C17 or KX3B according to NF C 93-550, external diameter 2.54 mm, maximum length 15 m. The cable shielding must be earthed.

#### Options common to all drives (continued)

#### “Preventa type ATE” fault relay - VW3 AE 1503

Scheme conforming to standards EN 954-1 category 3, IEC/EN 61508 capacity SIL 2, stopping category 1 in accordance with IEC/EN 60204-1

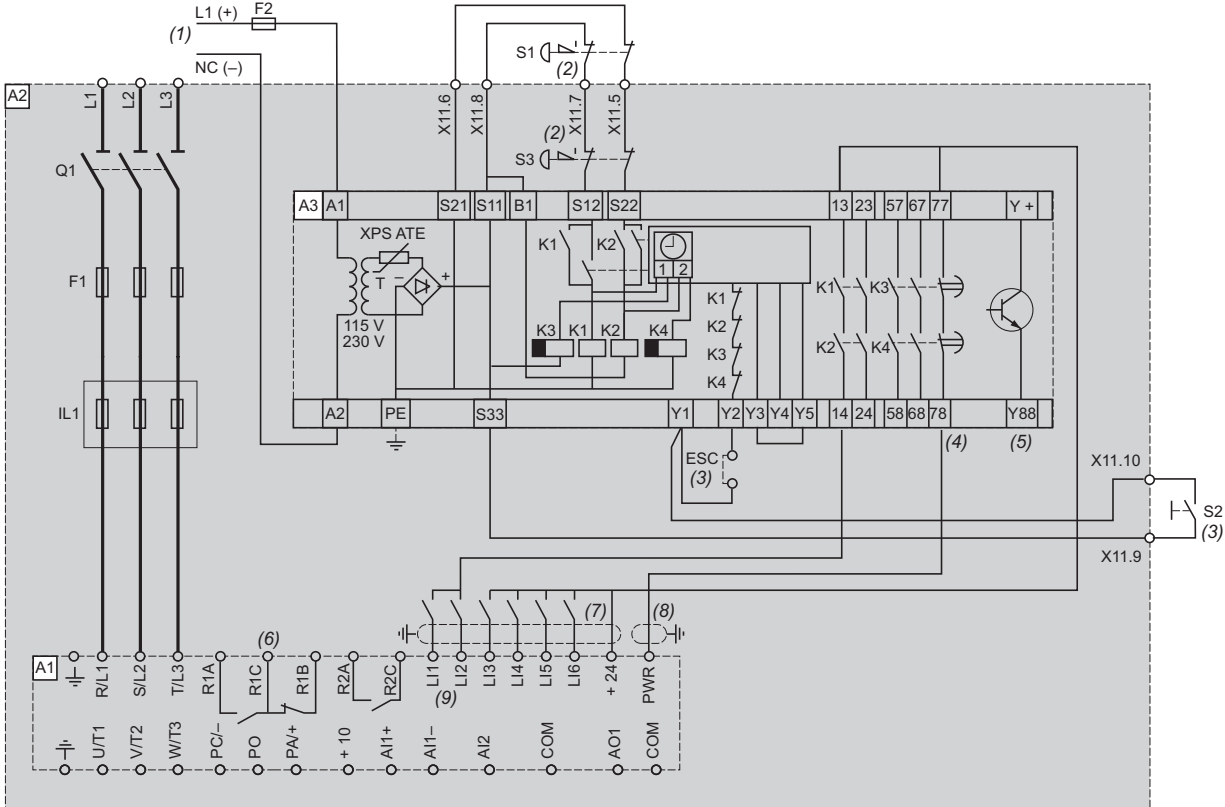

Ref.	Description
A1	ATV 61 drive (see pages 21 and 23)
A2	ATV 61EXC compact floor-standing enclosure (see pages 50 and 51)
A3	Preventa XPS ATE safety module for monitoring emergency stops and switches. One safety module can manage the Power Removal safety function for several drives on the same machine. In this case the time delay must be adjusted on the drive controlling the motor that requires the longest stopping time. In addition, the PWR terminal on each drive must be connected to the + 24 V via the safety contacts on the XPS ATE module. These contacts are independent for each drive.
F1	Fast-acting fuse
F2	Fuse
IL1	Line choke
Q1	Switch
S1	Emergency stop button with 2 contacts
S2	Run button
S3	Emergency stop button with 2 contacts, mounted on enclosure door

- (1) Power supply: 24 V  $\square$ , 230 V  $\sim$ .  
 (2) Requests controlled stopping of the movement and activates the Power Removal safety function.  
 (3) S2: Resets XPS ATE module on power-up or after an emergency stop. ESC can be used to set external starting conditions.  
 (4) For stopping times requiring more than 30 seconds in category 1, use a Preventa XPS AV safety module which can provide a maximum time delay of 300 seconds.  
 (5) The logic output can be used to indicate that the machine is in a safe state.  
 (6) Fault relay contacts. For remote signalling of drive status.  
 (7) Connection of the common for the logic inputs depends on the position of switch SW1 (see schemes on page 214).  
 (8) Standardized coaxial cable, type RG174/U according to MIL-C17 or KX3B according to NF C 93-550, external diameter 2.54 mm, maximum length 15 m. The cable shielding must be earthed.  
 (9) Logic inputs LI1 and LI2 must be assigned to the direction of rotation: LI1 to forward direction and LI2 to reverse direction.



#### Options common to all drives (continued)

##### Enclosure lighting - VW3 AE 1601

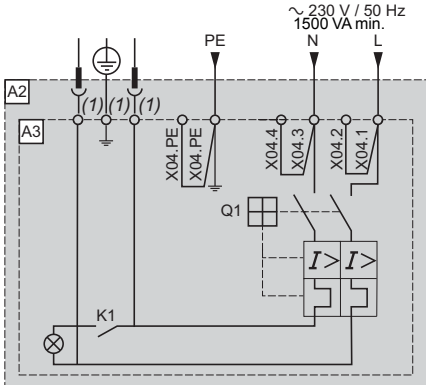

Ref.	Description
A2	ATV 61EXC● compact floor-standing enclosure (see pages 50 and 51)
A3	Enclosure lighting
K1	Door contact
Q1	6 A circuit-breaker

(1) European standard power socket available.

##### Additional electrical input isolation - VW3 AE 1901

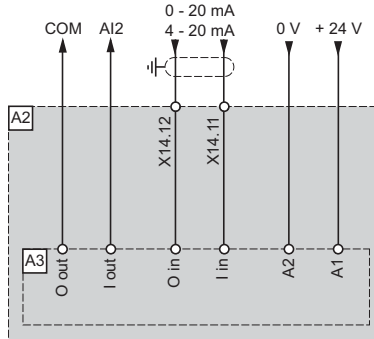

Ref.	Description
A2	ATV 61EXC● compact floor-standing enclosure (see pages 50 and 51)
A3	Additional electrical input isolation

##### Additional electrical output isolation - VW3 AE 1902

###### AO1 analog output option

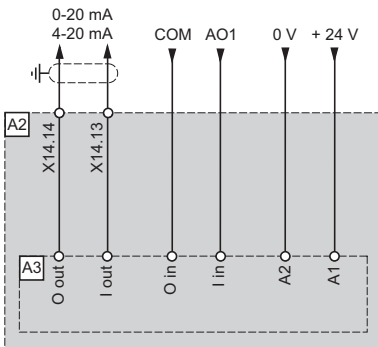

Ref.	Description
A2	ATV 61EXC● compact floor-standing enclosure (see pages 50 and 51)
A3	Additional electrical output isolation

###### AO2 analog output option

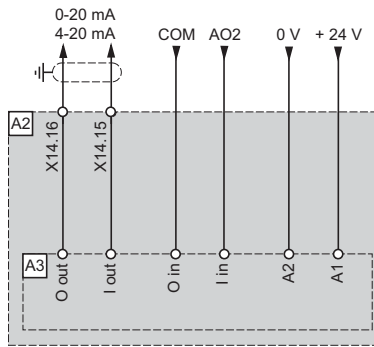

Ref.	Description
A2	ATV 61EXC● compact floor-standing enclosure (see pages 50 and 51)
A3	Additional electrical output isolation

###### AO3 analog output option

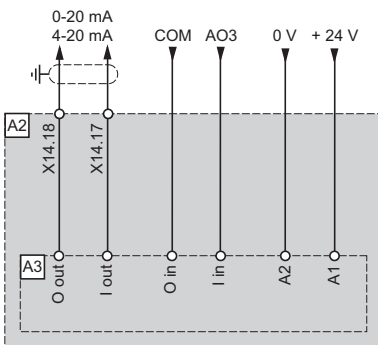

Ref.	Description
A2	ATV 61EXC● compact floor-standing enclosure (see pages 50 and 51)
A3	Additional electrical output isolation

#### Options common to all drives (continued)

##### PTC relay - VW3 AE 2001

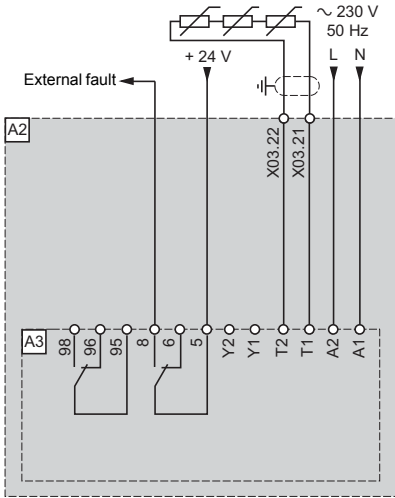

Ref.	Description
A2	ATV 61EXC● compact floor-standing enclosure (see pages 50 and 51)
A3	PTC relay

##### PTC relay with PTB (ATEX) certification (1) - VW3 AE 2002

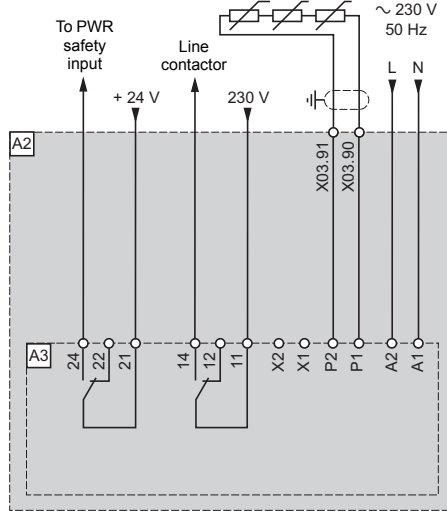

Ref.	Description
A2	ATV 61EXC● compact floor-standing enclosure (see pages 50 and 51)
A3	PTC relay with PTB (ATEX) certification

(1) ATEX: See pages 208 and 209

##### Relay for PT100 for motor winding - VW3 AE 2003

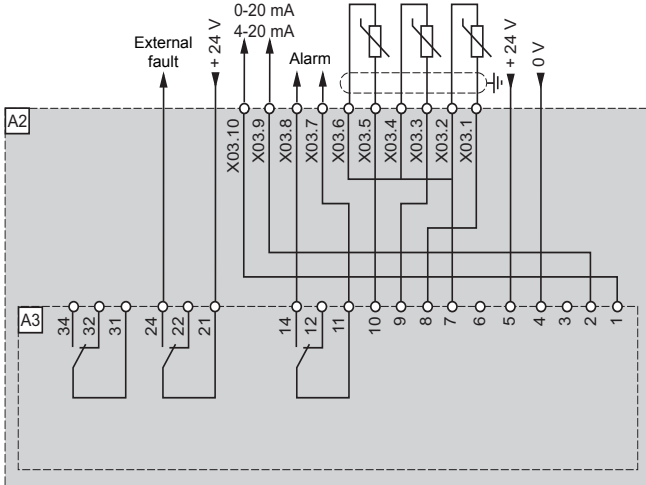

Ref.	Description
A2	ATV 61EXC● compact floor-standing enclosure (see pages 50 and 51)
A3	PT100 relay for motor winding

##### PT100 relay for motor bearings - VW3 AE 2004

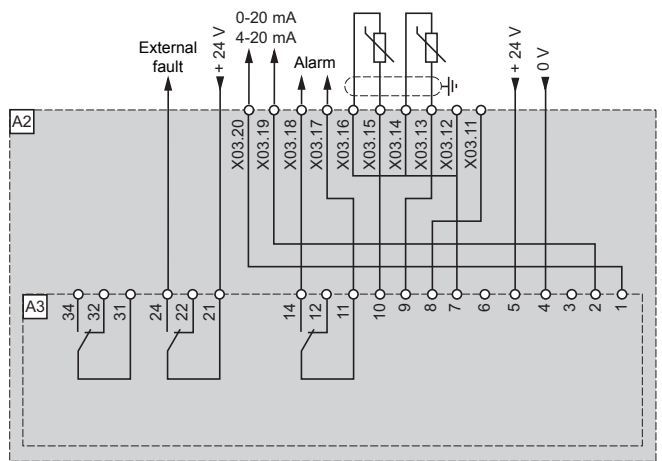

Ref.	Description
A2	ATV 61EXC● compact floor-standing enclosure (see pages 50 and 51)
A3	PT100 relay for motor bearings

#### Options common to all drives (continued)

##### Motor heater - VW3 AE 2101

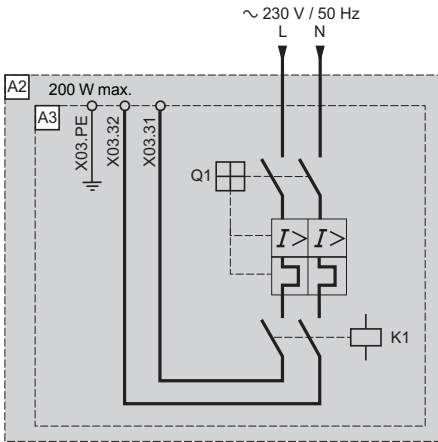

Ref.	Description
A2	ATV 61EXC● compact floor-standing enclosure (see pages 50 and 51)
A3	Motor heater
K1	Controlled by the drive or the line contactor. This control is activated if the drive is at "Stop" state.
Q1	Circuit-breaker

##### Power supply circuit with protection for external fan - VW3 AE 2102

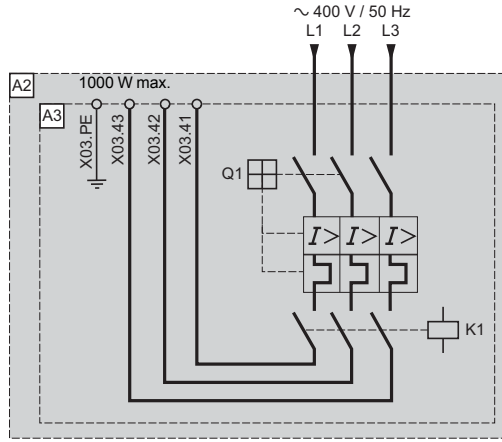

Ref.	Description
A2	ATV 61EXC● compact floor-standing enclosure (see pages 50 and 51)
A3	Power supply circuit with protection
K1	Controlled by the drive or the line contactor. This control is activated if the drive is at "RUN" state.
Q1	Circuit-breaker

##### Relay for logic output - VW3 AE 2201

###### Logic output LO1

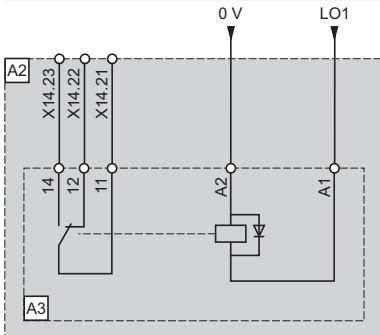

Ref.	Description
A2	ATV 61EXC● compact floor-standing enclosure (see pages 50 and 51)
A3	Relay for logic output

###### Logic output LO2

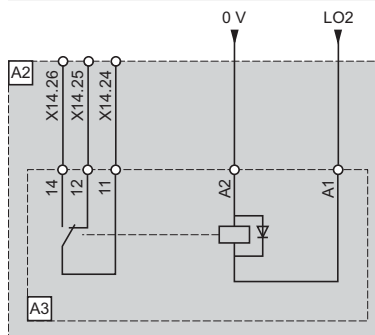

Ref.	Description
A2	ATV 61EXC● compact floor-standing enclosure (see pages 50 and 51)
A3	Relay for logic output

###### Logic output LO3

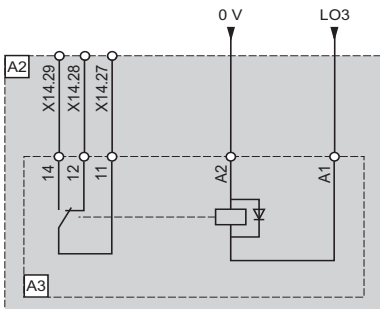

Ref.	Description
A2	ATV 61EXC● compact floor-standing enclosure (see pages 50 and 51)
A3	Relay for logic output

###### Logic output LO4

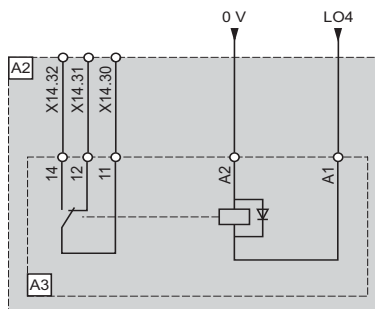

Ref.	Description
A2	ATV 61EXC● compact floor-standing enclosure (see pages 50 and 51)
A3	Relay for logic output

### Options dependent on the drive rating

**Braking units - VW3 A7E 101, VW3 AE 1003...1005**

**ATV 61EXC●C25N4...C63N4, ATV 61EXC●C20N...C63N, ATV 61EXC●C25Y...C80Y**

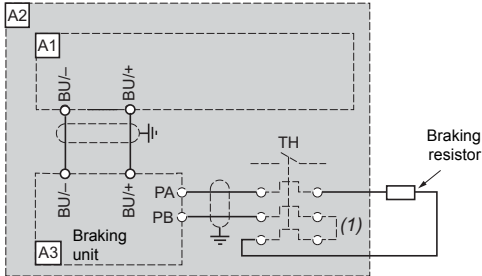

### Components for use together

Ref.	Description
A1	ATV 61 drive (see pages 21 and 23)
A2	ATV 61EXC● compact floor-standing enclosure (see pages 50 and 51)
A3	Braking unit (see pages 54 and 57)
<b>Braking resistor</b>	
	See pages 140 and 141

(1) A thermal overload relay can be added; its contact must then be integrated into the control circuit.

### 500 VA or 800 VA ~ control transformers - VW3 AE 0302, VW3 AE 0303

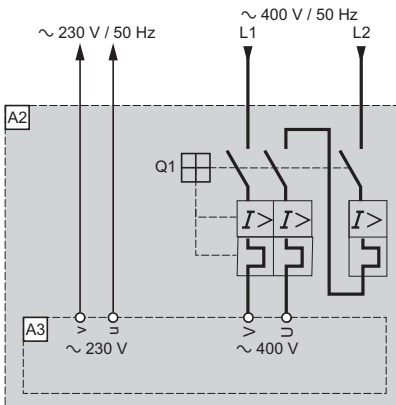

Ref.	Description
A2	ATV 61EXC●D90N4...C63N4 compact floor-standing enclosure (see pages 50 and 51)
A3	500 VA ~ or 800 VA ~ control transformer
Q1	Circuit-breaker

# Variable speed drives

## Altivar 61

### UL Type 12/IP 54 drives with Vario



ATV 61E5●●●N4

#### Presentation

Altivar 61 UL Type 12/IP 54 variable speed drives can be supplied equipped with a Vario switch disconnector.

This ready-assembled offer, ATV 61E5●●●N4, is specially designed for applications that require an accessible drive as close as possible to the motor (such as in fluid, waste water and air treatment applications).

It covers motor power ratings between 0.75 kW and 90 kW, with a three-phase supply voltage of between 380 and 480 V.

#### Description

The ready-assembled Altivar 61 offer, **ATV 61E5●●●N4**, comprises:

- An **ATV 61W●●●N4** drive **1**
- A Vario switch disconnector **2**

One or two (maximum) control units (pushbutton, switch, etc.) and/or signalling units (LED) can be added on the front of the drive (1) (2).

**Note:** For the connection diagrams, see pages 206 to 227, and for the mounting and installation recommendations, see pages 252 and 253.

#### Options

The following options, available for ATV 61W●●●N4 drives, can be used at the same rating with the ATV 61E5●●●N4 offer:

- Adaptor for 115 V ~ logic inputs
- Ready-assembled IP 54 baseplate
- Option cards: Encoder interface, I/O extension, multi-pump, programmable "Controller Inside" and communication
- Braking resistors
- Line chokes and passive filters
- Motor chokes and sinus filters
- PowerSuite software workshop

See the tables summarizing the possible combinations for Altivar 61 UL Type 12/IP 54 drives to determine the options available for each drive (see pages 174, 175, 178 and 179).

**Note:** UL Type 1, IP 21 or IP 31 conformity kits are not necessary for this range.

(1) The customer is responsible for drilling the front panel and mounting the control or signalling units (see page 77).

(2) Please refer to the "Control and signalling components" catalogue.

**Connection characteristics (terminals for the power supply, motor, DC bus and braking resistor) (1)**

Drive terminals	L1/R, L2/S, L3/T	U/T1, V/T2, W/T3, PC/-, PO, PA/+, PA, PB
<b>Maximum wire size and tightening torque</b>		
ATV 61E5075N4...E5U55N4	10 mm <sup>2</sup> , AWG 6 2.1 Nm, 18.3 lb.in	4 mm <sup>2</sup> , AWG 10 1.4 Nm, 12.3 lb.in
ATV 61E5U75N4, E5D11N4	25 mm <sup>2</sup> , AWG 2 5.6 Nm, 50 lb.in	6 mm <sup>2</sup> , AWG 8 3 Nm, 26.5 lb.in
ATV 61E5D15N4	25 mm <sup>2</sup> , AWG 2 5.6 Nm, 50 lb.in	16 mm <sup>2</sup> , AWG 4 3 Nm, 26.5 lb.in
ATV 61E5D18N4, E5D22N4	25 mm <sup>2</sup> , AWG 2 5.6 Nm, 50 lb.in	35 mm <sup>2</sup> , AWG 2 5.4 Nm, 47.7 lb.in
ATV 61E5D30N4	25 mm <sup>2</sup> , AWG 2 5.6 Nm, 50 lb.in	50 mm <sup>2</sup> , AWG 1/0 12 Nm, 102.2 lb.in
ATV 61E5D37N4...E5D45N4	95 mm <sup>2</sup> , AWG 4/0 22.6 Nm, 200 lb.in	50 mm <sup>2</sup> , AWG 1/0 12 Nm, 102.2 lb.in
ATV 61E5D55N4...E5D90N4	95 mm <sup>2</sup> , AWG 4/0 22.6 Nm, 200 lb.in	150 mm <sup>2</sup> , 300 MCM 41 Nm, 360 lb.in

(1) Other characteristics identical to those of ATV 61W●●●N4 drives at the same rating (see pages 10 to 17).

# Variable speed drives

## Altivar 61

### UL Type 12/IP 54 drives with Vario

524666



ATV 61E5D11N4

UL Type 12/IP 54 drives with Vario and integrated class A EMC filter											
Three-phase supply voltage: 380...480 V 50/60 Hz											
Motor		Line supply				Altivar 61			Reference (3)	Weight	
Power indicated on plate (1)		Max. line current (2)		Apparent power	Max. prospective line Isc	Max. continuous current In (1)		Max. transient current for 60 s			
kW	HP	380 V	480 V	380 V	kA	380 V	460 V				
		A	A	kVA	kA	A	A	A		kg	
0.75	1	1.8	1.5	1.2	5	2.3	2.1	2.5	ATV 61E5075N4	16.400	
1.5	2	3.5	3	2.3	5	4.1	3.4	4.5	ATV 61E5U15N4	16.400	
2.2	3	5	4.1	3.3	5	5.1	4.8	5.6	ATV 61E5U22N4	16.400	
3	–	6.7	5.6	4.4	5	7.2	6.2	7.9	ATV 61E5U30N4	16.400	
4	5	8.8	7.4	5.8	5	9.1	7.6	10	ATV 61E5U40N4	18.400	
5.5	7.5	11.4	9.2	7.5	22	12	11	13.2	ATV 61E5U55N4	18.400	
7.5	10	15.8	13.3	10.4	22	16	14	17.6	ATV 61E5U75N4	22.700	
11	15	21.9	17.8	14.4	22	22.5	21	24.7	ATV 61E5D11N4	22.700	
15	20	30.5	25.8	20	22	30.5	27	33.5	ATV 61E5D15N4	36.700	
18.5	25	37.5	32.3	24.7	22	37	34	40.7	ATV 61E5D18N4	45.400	
22	30	43.6	36.6	28.7	22	43.5	40	47.8	ATV 61E5D22N4	45.400	
30	40	56.7	46.2	37.3	22	58.5	52	64.3	ATV 61E5D30N4	52.800	
37	50	69.5	56.8	45.7	22	71.5	65	78.6	ATV 61E5D37N4	65.800	
45	60	85.1	69.6	56	22	85	77	93.5	ATV 61E5D45N4	65.800	
55	75	104.8	87	69	35	103	96	113.3	ATV 61E5D55N4	84.400	
75	100	140.3	113.8	92.3	35	137	124	150.7	ATV 61E5D75N4	84.400	
90	125	171.8	140.9	113	35	163	156	179.3	ATV 61E5D90N4	84.400	

(1) These values are given for a nominal switching frequency of 8 kHz up to ATV 61E5D15N4 or 4 kHz for ATV 61E5D18N4... E5D90N4 drives for use in continuous operation.  
The switching frequency is adjustable from 2...16 kHz for all ratings.  
Above 4 or 8 kHz, depending on the rating, the drive will reduce the switching frequency automatically in the event of excessive temperature rise. For continuous operation above the nominal switching frequency, derate the nominal drive current (see derating curves on pages 252 and 253).

(2) Typical value for the indicated motor power and for the maximum prospective line Isc.

(3) All drives are supplied with a European version EMC plate mounted.

#### ATV 61E5075N4...E5D90N4 drives

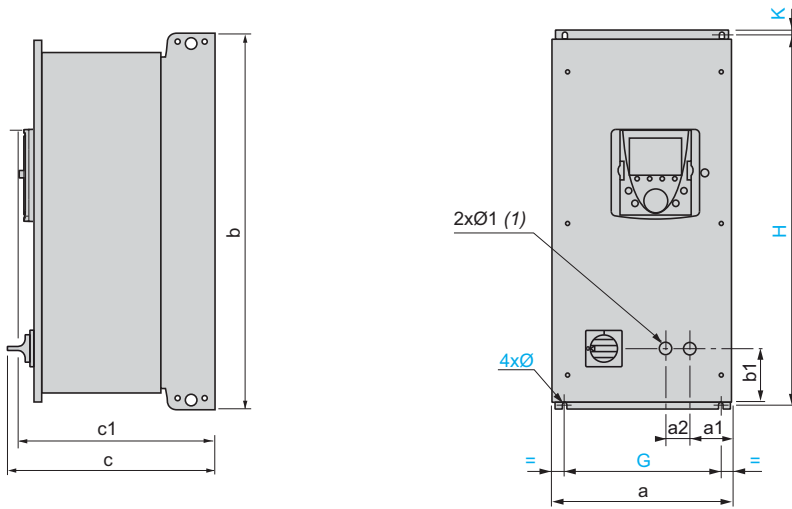

ATV 61E5	a	a1	a2	b	b1	c	c1	G	H	K	$\varnothing$	$\varnothing 1$
075N4...U30N4	240	60.5	30	490	80	296	272	200	476	6	6	22.3
U40N4, U55N4	240	60.5	30	490	80	310	286	200	476	6	6	22.3
U75N4, D11N4	260	60.5	30	525	80	310	286	220	511	6	6	22.3
D15N4	295	77	30	560	80	339	315	250	544	8	6	22.3
D18N4, D22N4	315	77	30	665	81	340	315	270	647	10	6	22.3
D30N4	285	73	30	720	119	335	315	245	700	10	7	22.3
D37N4, D45N4	285	69	30	880	218	383	343	245	860	10	7	22.3
D55N4...D90N4	362	102	30	1000	280	404	364	300	975	10	9	22.3

(1) The diameters and positions of the drill holes for mounting control and/or signalling units must be complied with.  
The customer is responsible for drilling and mounting units.



# Variable speed drives

## Altivar 61

IP 54 floor-standing enclosure with separate air flows

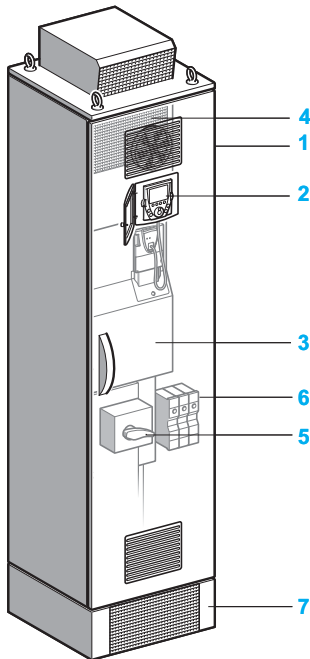

### Presentation

Altivar 61 variable speed drives can be supplied ready-assembled in an IP 54 floor-standing enclosure to facilitate installation and setup and, in particular, to ensure optimum ventilation of the enclosure.

The ATV 61EXS5..... offer consists of a floor-standing enclosure providing IP 54 protection with separate cooling circuits, for harsh and highly polluted environments (such as in tunnels, subways, smoke extraction and pumping applications, etc.). The enclosure is supplied ready to connect.

The ATV 61EXS5..... offer covers motor power ratings from 90 kW to 800 kW with three types of power supply:

- 380...415 V three-phase, 90 kW to 630 kW (**ATV 61EXS5...N4**)
- 500 V three-phase, 90 kW to 630 kW (**ATV 61EXS5...N**)
- 600...690 V three-phase, 110 kW to 800 kW (**ATV 61EXS5...Y**)

The ATV 61EXS5..... offer includes the choice of:

- A standard separate air flow offer
- A modular offer in which a wide selection of options can be incorporated according to the rating of the drive

### Standard separate air flow offer

This consists of:

- A wired, ready-assembled Sarel "Spacial 6000" enclosure **1**
- An ATV 61HD90N4...HC63N4 or ATV 61HC11Y...ATV 61HC80Y drive on heatsink **3**
- An IP 65 remote mounting kit for graphic display terminal **2**
- A DC choke **4** (ATV 61EXS5...N4) or a line choke in an additional enclosure (ATV 61EXS5...N, ATV 61EXS5...Y)
- A switch and fast-acting fuses **5**
- Motor terminals **6**
- A plinth **7**

See page 84.

### Modular offer

This consists of:

- The standard separate air flow offer
- One or more options (see pages 85 to 91)

As well as these specific options, all the options available for Altivar 61 drives can be used at the same rating with the enclosed drives offer (see pages 172, 173 and 176 to 179).

For any configurations other than those shown on pages 85 to 91, please consult your Regional Sales Office.

### Common options (modular offer only)

- Adaptor for 115 V ~ logic inputs
- Encoder interface cards
- I/O extension cards
- Multi-pump and "Controller Inside" programmable cards
- Modbus TCP, EtherNet/IP, Fipio, Modbus Plus, DeviceNet, INTERBUS, CC-Link, Modbus/Uni-Telway, PROFIBUS DP, LonWORKS, METASYS N2, APOGEE FLN, BACnet communication cards
- PT100 relays, PTC relays
- Motor heater
- Additional 24 V ~ power supply
- Emergency stop button
- Key switch (Local/Remote)
- Power supply circuit for external fan

See pages 85 and 86.

### Options dependent on the drive rating (modular offer only)

- Braking unit
- Isolating handle for switch
- Circuit-breaker
- Line contactor
- Control transformer
- Ammeter
- Enclosure heater
- Motor choke
- Sinus filter
- Cable entry via the top
- Air conditioning

See pages 87 to 91.

### Ventilation

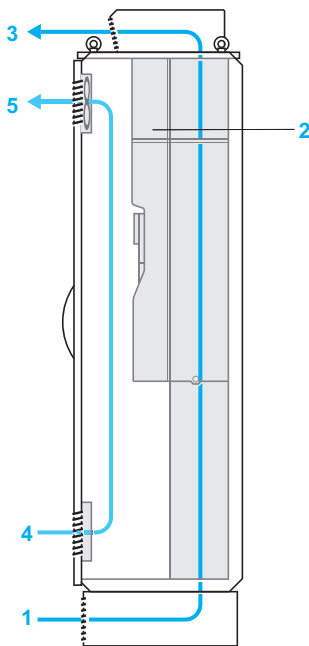

Two separate air circuits ensure optimum enclosure ventilation, cooling the power section and the control section.

#### Power section:

- 1 Air intake via a grille on the plinth
- 2 DC choke
- 3 Air outlet via a metal cover with protection against water splashes on the enclosure roof

#### Control section:

- 4 Air intake via a grille with IP 54 filter on the lower part of the enclosure door
- 5 Air outlet via a grille with a fan equipped with an IP 54 filter on the upper part of the enclosure door

Specific characteristics			
Enclosure degree of protection			IP 54 Two separate air circuits ensure optimum enclosure ventilation, cooling: <ul style="list-style-type: none"> <li>■ The power section: <ul style="list-style-type: none"> <li>□ Air intake via a grille on the plinth</li> <li>□ Air outlet via a cover on the roof</li> </ul> </li> <li>■ The power section: <ul style="list-style-type: none"> <li>□ Air intake via a grille with IP 54 filter on the lower part of the door</li> <li>□ Air outlet via a grille and IP 54 fan on the upper part of the door</li> </ul> </li> </ul>
Line supply connection			At the base of the switch
Motor connection	ATV 61EXS5D90N4...C31N4 ATV 61EXS5D90N...C31N ATV 61EXS5C11Y...C40Y		On the terminals
	ATV 61EXS5C40N4...C63N4 ATV 61EXS5C40N...C63N ATV 61EXS5C50Y...C80Y		On the bars of the drive On additional bars
Control terminal connection			Directly on the drive or on option terminals
Colour of SAREL Spacial 6000 enclosures			RAL 7032 enclosure RAL 7022 plinth
Environmental characteristics (1)			
Maximum ambient pollution Definition of insulation			Degree 2 conforming to IEC/EN 61800-5-1
Vibration resistance			Conforming to standard IEC/EN 60068-2-6 1.5 mm peak to peak from 3 to 10 Hz, 0.6 g from 10 to 200 Hz (3M3 according to IEC/EN 60721-3-3)
Shock resistance			Conforming to standard IEC/EN 60068-2-7 4 g for 11 ms (3M2 according to IEC/EN 60721-3-3)
Environmental conditions Use			IEC/EN 60721-3-3 classes 3C2, 3S2 and 3K3, without condensation
Maximum relative humidity			95%
Ambient air temperature	Operation	°C	Incoming air temperature: 0...+ 40 (- 10...+ 40 with enclosure heater) Up to + 50°C with derating. 3K3 according to IEC/EN 60721-3-3
	Storage	°C	- 25...+ 70
	Control		Internal temperature monitored by a thermostat which can shut down the equipment
Volume of cooling air	ATV 61EXS5D90N4, C11N4	m³/h	500
	ATV 61EXS5C13N4	m³/h	700
	ATV 61EXS5C16N4	m³/h	750
	ATV 61EXS5C22N4	m³/h	950
	ATV 61EXS5C25N4, C31N4	m³/h	1400
	ATV 61EXS5C40N4	m³/h	2200
	ATV 61EXS5C50N4	m³/h	2300
	ATV 61EXS5C63N4	m³/h	3000
	ATV 61EXS5D90N...C16N ATV 61EXS5C11Y...C20Y	m³/h	750
	ATV 61EXS5C20N...C31N ATV 61EXS5C25Y...C40Y	m³/h	1400
	ATV 61EXS5C40N...C63N ATV 61EXS5C50Y...C80Y	m³/h	3000
Electrical power characteristics (1)			
Power supply	Voltage	V	380 V – 15%...415 V +10% for ATV 61EXS5●●●N4 500 V – 15% for ATV 61EXS5●●●N 600...690 V +10% for ATV 61EXS5●●●Y
	Frequency	Hz	50/60 Hz ± 5%
Overvoltage class			Class 3 according to EN 50178
Noise level	ATV 61EXS5 D90N4...C13N4 D90N...C16N C11Y...C20Y	dBA	64
	C16N4...C31N4 C20N...C31N C25Y...C40Y	dBA	72
	C40N4...C63N4 C40N...C63N C50Y...C80Y	dBA	73

(1) For other characteristics, see pages 10 to 17.

### Connection characteristics

Three-phase supply voltage 380...415 V 50/60 Hz

Drive terminals		Power supply		L1/R, L2/S, L3/T		U/T1, V/T2, W/T3				Recom- mended cross- section for motor cables
		Upstream fuse protection	Maximum wire size on switch		Fast- acting fuse	Maximum wire size on terminals				
						Without motor choke		With motor choke		
			Bar	Ter- minals		Bar	Ter- minals	Bar	Ter- minals	
A	mm <sup>2</sup>	mm <sup>2</sup>	A	mm <sup>2</sup>	mm <sup>2</sup>	mm <sup>2</sup>	mm <sup>2</sup>	mm <sup>2</sup>		
Cable entry via the bottom	ATV 61EXS5D90N4	250	M10, 2 x 120	–	250	–	2 x 120	–	2 x 120	3 x 95
	ATV 61EXS5C11N4	315	M10, 2 x 120	–	315	–	2 x 120	–	2 x 120	3 x 120
	ATV 61EXS5C13N4	400	M10, 2 x 120	–	400	–	2 x 120	–	2 x 120	3 x 150
	ATV 61EXS5C16N4	400	M10, 2 x 150	–	400	–	2 x 120	–	2 x 120	2 (3 x 95)
	ATV 61EXS5C22N4	500	2 x M12, 4 x 240	–	500	–	2 x 185	2 x M12, 4 x 240	–	2 (3 x 120)
	ATV 61EXS5C25N4	630	2 x M12, 4 x 240	–	630	–	4 x 120	2 x M12, 4 x 240	–	2 (3 x 150)
	ATV 61EXS5C31N4	800	2 x M12, 4 x 240	–	700	–	4 x 120	2 x M12, 4 x 240	–	3 (3 x 150)
	ATV 61EXS5C40N4	800	2 x M12, 4 x 240	–	800	2 x M12, 4 x 240	–	2 x M12, 4 x 240	–	3 (3 x 185)
	ATV 61EXS5C50N4	1000	2 x M12, 4 x 240	–	2 x 500	2 x M12, 4 x 240	–	2 x M12, 4 x 240	–	4 (3 x 185)
	ATV 61EXS5C63N4	1250	3 x M12, 6 x 240	–	2 x 630	3 x M12, 6 x 240	–	3 x M12, 6 x 240	–	5 (3 x 185)
Cable entry via the top	ATV 61EXS5D90N4	250	–	2 x 120	250	–	2 x 120	–	2 x 120	3 x 95
	ATV 61EXS5C11N4	315	–	2 x 120	315	–	2 x 120	–	2 x 120	3 x 120
	ATV 61EXS5C13N4	400	–	2 x 120	400	–	2 x 120	–	2 x 120	3 x 150
	ATV 61EXS5C16N4	400	–	2 x 120	400	–	2 x 120	–	2 x 120	2 (3 x 95)
	ATV 61EXS5C22N4	500	–	2 x 185	500	–	2 x 185	2 x M12, 4 x 240	–	2 (3 x 120)
	ATV 61EXS5C25N4	630	–	4 x 120	630	–	4 x 120	2 x M12, 4 x 240	–	2 (3 x 150)
	ATV 61EXS5C31N4	800	–	4 x 120	700	–	4 x 120	2 x M12, 4 x 240	–	3 (3 x 150)
	ATV 61EXS5C40N4	800	2 x M12, 4 x 240	–	800	2 x M12, 4 x 240	–	2 x M12, 4 x 240	–	3 (3 x 185)
	ATV 61EXS5C50N4	1000	2 x M12, 4 x 240	–	2 x 500	2 x M12, 4 x 240	–	2 x M12, 4 x 240	–	4 (3 x 185)
	ATV 61EXS5C63N4	1250	3 x M12, 6 x 240	–	2 x 630	3 x M12, 6 x 240	–	3 x M12, 6 x 240	–	5 (3 x 185)

### Connection characteristics (continued)

Three-phase supply voltage 500 V 50/60 Hz

Drive terminals		Power supply	L1/R, L2/S, L3/T			U/T1, V/T2, W/T3				Recom- mended cross- section for motor cables	
			Upstream fuse protection	Maximum wire size on switch		Fast- acting fuse	Maximum wire size on terminals				
				Bar	Ter- minals		Without motor choke		With motor choke		
							Bar	Ter- minals	Bar		Ter- minals
A	mm <sup>2</sup>	mm <sup>2</sup>	A	mm <sup>2</sup>	mm <sup>2</sup>	mm <sup>2</sup>	mm <sup>2</sup>	mm <sup>2</sup>			
Cable entry via the bottom	ATV 61EXS5D90N	160	M10, 2 x 120	–	160	–	2 x 185	–	2 x 185	3 x 70	
	ATV 61EXS5C11N	200	M10, 2 x 120	–	200	–	2 x 185	–	2 x 185	3 x 70	
	ATV 61EXS5C13N	250	M10, 2 x 120	–	250	–	2 x 185	–	2 x 185	3 x 95	
	ATV 61EXS5C16N	315	M10, 2 x 120	–	315	–	2 x 185	–	2 x 185	3 x 120	
	ATV 61EXS5C20N	400	2 x M12, 4 x 240	–	400	–	4 x 120	4 x M12, 6 x 240	–	3 x 185	
	ATV 61EXS5C25N	500	2 x M12, 4 x 240	–	500	–	4 x 120	4 x M12, 6 x 240	–	2 (3 x 120)	
	ATV 61EXS5C31N	630	2 x M12, 4 x 240	–	630	–	4 x 120	4 x M12, 6 x 240	–	2 (3 x 150)	
	ATV 61EXS5C40N	800	3 x M12, 6 x 240	–	2 x 400	3 x M12, 6 x 240	–	4 x M12, 6 x 240	–	3 (3 x 150)	
	ATV 61EXS5C50N	1000	3 x M12, 6 x 240	–	2 x 500	3 x M12, 6 x 240	–	4 x M12, 6 x 240	–	3 (3 x 185)	
	ATV 61EXS5C63N	1250	3 x M12, 6 x 240	–	2 x 630	3 x M12, 6 x 240	–	4 x M12, 6 x 240	–	4 (3 x 185)	
Cable entry via the top	ATV 61EXS5D90N	160	–	2 x 185	160	–	2 x 185	–	2 x 185	3 x 70	
	ATV 61EXS5C11N	200	–	2 x 185	200	–	2 x 185	–	2 x 185	3 x 70	
	ATV 61EXS5C13N	250	–	2 x 185	250	–	2 x 185	–	2 x 185	3 x 95	
	ATV 61EXS5C16N	315	–	2 x 185	315	–	2 x 185	–	2 x 185	3 x 120	
	ATV 61EXS5C20N	400	4 x M12, 6 x 240	–	400	4 x M12, 6 x 240	–	4 x M12, 6 x 240	–	3 x 185	
	ATV 61EXS5C25N	500	4 x M12, 6 x 240	–	500	4 x M12, 6 x 240	–	4 x M12, 6 x 240	–	2 (3 x 120)	
	ATV 61EXS5C31N	630	4 x M12, 6 x 240	–	630	4 x M12, 6 x 240	–	4 x M12, 6 x 240	–	2 (3 x 150)	
	ATV 61EXS5C40N	800	4 x M12, 6 x 240	–	2 x 400	4 x M12, 6 x 240	–	4 x M12, 6 x 240	–	3 (3 x 150)	
	ATV 61EXS5C50N	1000	4 x M12, 6 x 240	–	2 x 500	4 x M12, 6 x 240	–	4 x M12, 6 x 240	–	3 (3 x 185)	
	ATV 61EXS5C63N	1250	4 x M12, 6 x 240	–	2 x 630	4 x M12, 6 x 240	–	4 x M12, 6 x 240	–	4 (3 x 185)	

### Connection characteristics (continued)

Three-phase supply voltage 600...690 V 50/60 Hz

Drive terminals		Power supply	L1/R, L2/S, L3/T			U/T1, V/T2, W/T3				Recommended cross-section for motor cables
		Upstream fuse protection	Maximum wire size on switch		Fast-acting fuse	Maximum wire size on terminals				
						Without motor choke		With motor choke		
			Bar	Ter-minals		Bar	Ter-minals	Bar	Ter-minals	
A		mm <sup>2</sup>	mm <sup>2</sup>	A	mm <sup>2</sup>	mm <sup>2</sup>	mm <sup>2</sup>	mm <sup>2</sup>	mm <sup>2</sup>	
Cable entry via the bottom	ATV 61EXS5C11Y	160	M10, 2 x 120	–	160	–	2 x 185	–	2 x 185	3 x 70
	ATV 61EXS5C13Y	200	M10, 2 x 120	–	200	–	2 x 185	–	2 x 185	3 x 70
	ATV 61EXS5C16Y	250	M10, 2 x 150	–	250	–	2 x 185	–	2 x 185	3 x 95
	ATV 61EXS5C20Y	315	M10, 2 x 150	–	315	–	2 x 185	–	2 x 185	3 x 120
	ATV 61EXS5C25Y	400	2 x M12, 4 x 240	–	400	–	4 x 120	4 x M12, 6 x 240	–	3 x 185
	ATV 61EXS5C31Y	500	2 x M12, 4 x 240	–	500	–	4 x 120	4 x M12, 6 x 240	–	2 (3 x 120)
	ATV 61EXS5C40Y	630	2 x M12, 4 x 240	–	630	–	4 x 120	4 x M12, 6 x 240	–	2 (3 x 150)
	ATV 61EXS5C50Y	800	3 x M12, 6 x 240	–	2 x 400	3 x M12, 6 x 240	–	4 x M12, 6 x 240	–	3 (3 x 150)
	ATV 61EXS5C63Y	1000	3 x M12, 6 x 240	–	2 x 500	3 x M12, 6 x 240	–	4 x M12, 6 x 240	–	3 (3 x 185)
	ATV 61EXS5C80Y	1250	3 x M12, 6 x 240	–	2 x 630	3 x M12, 6 x 240	–	4 x M12, 6 x 240	–	4 (3 x 185)
Cable entry via the top	ATV 61EXS5C11Y	160	–	2 x 185	160	–	2 x 185	–	2 x 185	3 x 70
	ATV 61EXS5C13Y	200	–	2 x 185	200	–	2 x 185	–	2 x 185	3 x 70
	ATV 61EXS5C16Y	250	–	2 x 185	250	–	2 x 185	–	2 x 185	3 x 95
	ATV 61EXS5C20Y	315	–	2 x 185	315	–	2 x 185	–	2 x 185	3 x 120
	ATV 61EXS5C25Y	400	4 x M12, 6 x 240	–	400	4 x M12, 6 x 240	–	4 x M12, 6 x 240	–	3 x 185
	ATV 61EXS5C31Y	500	4 x M12, 6 x 240	–	500	4 x M12, 6 x 240	–	4 x M12, 6 x 240	–	2 (3 x 120)
	ATV 61EXS5C40Y	630	4 x M12, 6 x 240	–	630	4 x M12, 6 x 240	–	4 x M12, 6 x 240	–	2 (3 x 150)
	ATV 61EXS5C50Y	800	4 x M12, 6 x 240	–	2 x 400	4 x M12, 6 x 240	–	4 x M12, 6 x 240	–	3 (3 x 150)
	ATV 61EXS5C63Y	1000	4 x M12, 6 x 240	–	2 x 500	4 x M12, 6 x 240	–	4 x M12, 6 x 240	–	3 (3 x 185)
	ATV 61EXS5C80Y	1250	4 x M12, 6 x 240	–	2 x 630	4 x M12, 6 x 240	–	4 x M12, 6 x 240	–	4 (3 x 185)

# Variable speed drives

## Altivar 61

IP 54 floor-standing enclosure with separate air flows

524551



ATV 61EXS5C13N4

### IP 54 floor-standing enclosure with separate air flows

#### Three-phase supply voltage 380...415 V 50/60 Hz

Degree of protection	Line supply Max. prospective line Isc (1)	With drive	Reference	Weight
	kA			kg
IP 54	50	ATV 61HD90N4	ATV 61EXS5D90N4	310.000
		ATV 61HC11N4	ATV 61EXS5C11N4	310.000
		ATV 61HC13N4	ATV 61EXS5C13N4	335.000
		ATV 61HC16N4	ATV 61EXS5C16N4	345.000
		ATV 61HC22N4	ATV 61EXS5C22N4	395.000
		ATV 61HC25N4	ATV 61EXS5C25N4	480.000
		ATV 61HC31N4	ATV 61EXS5C31N4	480.000
		ATV 61HC40N4	ATV 61EXS5C40N4	745.000
		ATV 61HC50N4	ATV 61EXS5C50N4	765.000
		ATV 61HC63N4	ATV 61EXS5C63N4	900.000

#### Three-phase supply voltage 500 V 50/60 Hz

Degree of protection	Line supply Max. prospective line Isc (1)	With drive	Reference	Weight
	kA			kg
IP 54	50	ATV 61HC11Y	ATV 61EXS5D90N	446.000
		ATV 61HC13Y	ATV 61EXS5C11N	446.000
		ATV 61HC16Y	ATV 61EXS5C13N	497.000
		ATV 61HC20Y	ATV 61EXS5C16N	497.000
		ATV 61HC25Y	ATV 61EXS5C20N	573.000
		ATV 61HC31Y	ATV 61EXS5C25N	623.000
		ATV 61HC40Y	ATV 61EXS5C31N	623.000
		ATV 61HC50Y	ATV 61EXS5C40N	912.000
		ATV 61HC63Y	ATV 61EXS5C50N	1000.000
		ATV 61HC80Y	ATV 61EXS5C63N	1000.000

#### Three-phase supply voltage 600...690 V 50/60 Hz

Degree of protection	Line supply Max. prospective line Isc (1)	With drive	Reference	Weight
	kA			kg
IP 54	50	ATV 61HC11Y	ATV 61EXS5C11Y	446.000
		ATV 61HC13Y	ATV 61EXS5C13Y	446.000
		ATV 61HC16Y	ATV 61EXS5C16Y	497.000
		ATV 61HC20Y	ATV 61EXS5C20Y	497.000
		ATV 61HC25Y	ATV 61EXS5C25Y	573.000
		ATV 61HC31Y	ATV 61EXS5C31Y	623.000
		ATV 61HC40Y	ATV 61EXS5C40Y	623.000
		ATV 61HC50Y	ATV 61EXS5C50Y	912.000
		ATV 61HC63Y	ATV 61EXS5C63Y	1000.000
		ATV 61HC80Y	ATV 61EXS5C80Y	1000.000

(1) These values are given for use with upstream fuses (see pages 81 to 83).

## Variable speed drives

## Altivar 61

IP 54 floor-standing enclosure with separate air flows

Common options

Common options without modification of the enclosure <sup>(1)</sup>		
Description	Reference	Weight kg
Adaptor for 115 V ~ logic inputs	VW3 A3E 101 <sup>(2)</sup>	0.200
Encoder interface cards with RS 422, 5 V compatible differential outputs	VW3 A3E 401 <sup>(3)</sup>	0.200
Encoder interface card with 12 V open collector outputs	VW3 A3E 403 <sup>(3)</sup>	0.200
Encoder interface card with 15 V open collector outputs	VW3 A3E 404 <sup>(3)</sup>	0.200
Encoder interface card with 12 V push-pull outputs	VW3 A3E 405 <sup>(3)</sup>	0.200
Encoder interface card with 15 V push-pull outputs	VW3 A3E 406 <sup>(3)</sup>	0.200
Encoder interface card with 24 V push-pull outputs	VW3 A3E 407 <sup>(3)</sup>	0.200
Logic I/O extension card	VW3 A3E 201 <sup>(4)</sup>	0.320
Extended I/O extension card	VW3 A3E 202 <sup>(4)</sup>	0.300
Multi-pump card	VW3 A3E 502 <sup>(5)</sup> <sup>(6)</sup>	0.320
"Water solution" multi-pump card	VW3 A3E 503 <sup>(5)</sup> <sup>(6)</sup>	0.320
"Controller Inside" programmable card	VW3 A3E 501 <sup>(6)</sup> <sup>(7)</sup>	0.300
Modbus TCP communication card	VW3 A3E 310 <sup>(8)</sup>	0.300
EtherNet/IP communication card	VW3 A3E 316 <sup>(8)</sup>	0.300
Fipio communication card	VW3 A3E 311 <sup>(8)</sup>	0.300
Modbus Plus communication card	VW3 A3E 302 <sup>(8)</sup>	0.300
DeviceNet communication card	VW3 A3E 309 <sup>(8)</sup>	0.300
INTERBUS communication card	VW3 A3E 304 <sup>(8)</sup>	0.300
CC-Link communication card	VW3 A3E 317 <sup>(8)</sup>	0.320
Modbus/Uni-Telway communication card	VW3 A3E 303 <sup>(8)</sup>	0.300
PROFIBUS DP communication card	VW3 A3E 307 <sup>(8)</sup>	0.300
LonWORKS communication card	VW3 A3E 312 <sup>(8)</sup>	0.300
METASYS N2 communication card	VW3 A3E 313 <sup>(8)</sup>	0.300
APOGEE FLN communication card	VW3 A3E 314 <sup>(8)</sup>	0.300
BACnet communication card	VW3 A3E 315 <sup>(8)</sup>	0.300

<sup>(1)</sup> For any other configuration, please consult your Regional Sales Office.

<sup>(2)</sup> The technical characteristics of the VW3 A3E 101 adaptor are identical to those of the VW3 A3 101 adaptor (see page 26).

<sup>(3)</sup> The technical characteristics of the VW3 A3E 401 and 403...407 encoder interface cards are identical to those of the VW3 A3 401 and 403...407 encoder interface cards (see pages 110 and 111).

<sup>(4)</sup> The technical characteristics of the VW3 A3E 201 and VW3 A3E 202 I/O extension cards are identical to those of the VW3 A3 201 and VW3 A3 202 I/O extension cards (see pages 112 and 113).

<sup>(5)</sup> The technical characteristics of the VW3 A3E 502 and VW3 A3E 503 multi-pump cards are identical to those of the VW3 A3 502 and VW3 A3 503 multi-pump cards (see page 117).

<sup>(6)</sup> If the power consumption does not exceed 200 mA, this card can be powered by the drive. For a power consumption in excess of 200 mA, the additional 24 V ~ power supply option, reference VW3 AE 1401, should be ordered separately (see page 86).

<sup>(7)</sup> The technical characteristics of the VW3 A3E 501 "Controller Inside" programmable card are identical to those of the VW3 A3 501 "Controller Inside" programmable card (see page 120).

<sup>(8)</sup> The technical characteristics of the VW3 A3E 302...304, 307 and 309...317 communication cards are identical to those of the VW3 A3 302...304, 307 and 309...317 communication cards (see pages 128 to 133).



## Variable speed drives

## Altivar 61

IP 54 floor-standing enclosure with separate air flows

Common options

Common options without modification of the enclosure (continued) (1)		
Description	Reference	Weight kg
Remote control terminals X12	VW3 AE 1201	0.700
Remote option card terminals X13 (2) for I/O extension cards VW3 A3E 201 and 202	VW3 AE 1202	0.900
External 230 V ~ supply terminals	VW3 AE 1301	0.100
Additional 24 V $\square$ power supply, nominal current 2 A (3)	VW3 AE 1401	2.200
External 24 V $\square$ supply terminals	VW3 AE 1402	0.100
Emergency stop button	VW3 AE 1501	0.100
“Preventa type AC” fault relay	VW3 AE 1502	0.100
“Preventa type ATE” fault relay	VW3 AE 1503	0.100
Enclosure lighting	VW3 AE 1601	1.500
Key switch (Local/Remote)	VW3 AE 1801	0.200
Additional electrical input isolation	VW3 AE 1901	0.100
Additional electrical output isolation	VW3 AE 1902	0.100
PTC relay	VW3 AE 2001	0.100
PTC relay with PTB (ATEX) certification (4)	VW3 AE 2002	0.100
PT100 relay for motor winding	VW3 AE 2003	0.300
PT100 relay for motor bearings	VW3 AE 2004	0.300
Motor heater 200 W, 230 V	VW3 AE 2101	0.200
Power supply circuit with 400 V protection for 1000 W external fan	VW3 AE 2102	0.200
Relay for logic output	VW3 AE 2201	0.100
Voltmeter 380...415 V three-phase supply voltage	VW3 AE 2301	0.400
Voltmeter 500 V three-phase supply voltage	VW3 AE 2302	0.400
Voltmeter 600...690 V three-phase supply voltage	VW3 AE 2303	0.400

(1) For any other configuration, please consult your Regional Sales Office.

(2) The X13 terminals, reference VW3 AE 1202, include the X12 terminals, reference VW3 AE 1201.

(3) Essential if the power consumption of the option cards exceeds 200 mA.

(4) ATEX: See pages 208 and 209.

## Variable speed drives

## Altivar 61

IP 54 floor-standing enclosure with separate air flows

Options dependent on the drive rating

Options dependent on the drive rating (1)			
Three-phase supply voltage 380...415 V 50/60 Hz			
Description	For ATV 61 enclosure	Reference (2)	Weight kg
Resistance braking unit	EXS5C25N4...C31N4	VW3 A7E 101 (3)	31.000
	EXS5C40N4...C63N4	VW3 A7E 102 (3)	205.000
Isolating handle for switch	EXS5D90N4...C13N4	VW3 AE 0103	1.000
	EXS5C16N4...C31N4	VW3 AE 0104	2.000
	EXS5C40N4...C63N4	VW3 AE 0105	2.000
Circuit-breaker (4)	EXS5D90N4...C13N4	VW3 AE 0106	–
	EXS5C16N4	VW3 AE 0107	1.400
	EXS5C22N4	VW3 AE 0108	1.400
	EXS5C25N4	VW3 AE 0109	1.400
	EXS5C31N4	VW3 AE 0110	9.400
	EXS5C40N4	VW3 AE 0111	–
	EXS5C50N4	VW3 AE 0112	–
	EXS5C63N4	VW3 AE 0113	–
Door handle for circuit-breaker	EXS5D90N4...C13N4	VW3 AE 0114	1.000
	EXS5C16N4...C25N4	VW3 AE 0115	2.000
	EXS5C31N4...C63N4	VW3 AE 0116	2.000
230 V undervoltage coil for circuit-breaker	EXS5D90N4...C25N4	VW3 AE 0117	0.500
	EXS5C31N4...C63N4	VW3 AE 0118	0.500
110 V undervoltage coil for circuit-breaker	EXS5D90N4...C25N4	VW3 AE 0119	0.500
	EXS5C31N4...C63N4	VW3 AE 0120	0.500
230 V motor for circuit-breaker	EXS5D90N4...C13N4	VW3 AE 0121	0.950
	EXS5C16N4	VW3 AE 0122	3.000
	EXS5C22N4, C25N4	VW3 AE 0123	3.000
	EXS5C31N4, C40N4	VW3 AE 0124	7.000
	EXS5C50N4	VW3 AE 0125	7.000
	EXS5C63N4	VW3 AE 0126	7.000
110 V motor for circuit-breaker	EXS5D90N4...C13N4	VW3 AE 0127	0.950
	EXS5C16N4	VW3 AE 0128	3.000
	EXS5C22N4, C25N4	VW3 AE 0129	3.000
	EXS5C31N4, C40N4	VW3 AE 0130	7.000
	EXS5C50N4	VW3 AE 0131	7.000
	EXS5C63N4	VW3 AE 0132	7.000
Line contactor	EXS5D90N4	VW3 AE 0206	7.000
	EXS5C11N4	VW3 AE 0207	7.000
	EXS5C13N4	VW3 AE 0218	10.000
	EXS5C16N4	VW3 AE 0208	11.000
	EXS5C22N4...C31N4	VW3 AE 0216	10.000
	EXS5C40N4	VW3 AE 0211	21.000
	EXS5C50N4	VW3 AE 0213	28.000
	EXS5C63N4	VW3 AE 0214	42.000

(1) For any other configuration, please consult your Regional Sales Office.

(2) The options depend on the rating of the drive and may lead to modification of the size of the enclosure.

(3) The technical characteristics of the VW3 A7E 101 and VW3 A7E 102 braking units are identical to those of the VW3 A7 101 and VW3 A7 102 braking units (see page 136).

(4) The circuit-breaker replaces the switch in the standard compact offer.

## Variable speed drives

## Altivar 61

IP 54 floor-standing enclosure with separate air flows

Options dependent on the drive rating

## Options dependent on the drive rating (continued) (1)

Three-phase supply voltage 380...415 V 50/60 Hz (continued)

Description	For ATV 61 enclosure	Reference (2)	Weight kg
500 VA ~ control transformer, 230 V ~ output	EXS5D90N4...C22N4	VW3 AE 0302	8.000
800 VA ~ control transformer, 230 V ~ output	EXS5C25N4...C63N4	VW3 AE 0303	11.000
Ammeter	EXS5D90N4...C13N4	VW3 AE 0405	0.200
	EXS5C16N4	VW3 AE 0406	0.200
	EXS5C22N4...C31N4	VW3 AE 0408	0.200
	EXS5C40N4	VW3 AE 0409	0.200
	EXS5C50N4	VW3 AE 0410	0.200
	EXS5C63N4	VW3 AE 0411	0.200
Enclosure heater	EXS5D90N4...C31N4	VW3 AE 0501	0.500
	EXS5C40N4...C63N4	VW3 AE 0502	1.000
Motor choke	EXS5D90N4	VW3 AE 0615	37.000
	EXS5C11N4	VW3 AE 0616	55.000
	EXS5C13N4	VW3 AE 0617	55.000
	EXS5C16N4	VW3 AE 0618	154.000
	EXS5C22N4	VW3 AE 0619	157.000
	EXS5C25N4, C31N4	VW3 AE 0621	192.000
	EXS5C40N4	VW3 AE 0623	222.000
	EXS5C50N4	VW3 AE 0624	228.000
	EXS5C63N4	VW3 AE 0625	234.000
Sinus filter (3)	EXS5D90N4, C11N4	VW3 AE 0665	318.000
	EXS2C13N4	VW3 AE 0667	357.000
	EXS5C16N4	VW3 AE 0668	365.000
	EXS5C22N4	VW3 AE 0670	384.000
	EXS5C25N4, C31N4	VW3 AE 0672	434.000
	EXS5C40N4	VW3 AE 0674	870.000
	EXS5C50N4	VW3 AE 0675	900.000
	EXS5C63N4	VW3 AE 0676	930.000

(1) For any other configuration, please consult your Regional Sales Office.

(2) The options depend on the rating of the drive and may lead to modification of the size of the enclosure.

(3) Option not compatible with the "Cable entry via the top" option.

## Variable speed drives

## Altivar 61

IP 54 floor-standing enclosure with separate air flows

Options dependent on the drive rating

Options dependent on the drive rating (continued) (1)					
Three-phase supply voltage 380...415 V 50/60 Hz (continued)					
Description	Use	For ATV 61 enclosure	Reference (2)	Weight kg	
Cable entry via the top (3)	Without motor choke	EXS5D90N4...C13N4	VW3 AE 0715	123.000	
		EXS5C16N4	VW3 AE 0716	123.000	
		EXS5C22N4	VW3 AE 0717	123.000	
		EXS5C25N4, C31N4	VW3 AE 0718	141.000	
		EXS5C40N4	VW3 AE 0719	123.000	
		EXS5C50N4	VW3 AE 0720	141.000	
		EXS5C63N4	VW3 AE 0721	141.000	
	With motor choke	EXS5C22N4	VW3 AE 0722	123.000	
		EXS5C25N4, C31N4	VW3 AE 0723	141.000	
		EXS5C40N4	VW3 AE 0724	–	
		EXS5C50N4	VW3 AE 0725	–	
		EXS5C63N4	VW3 AE 0726	–	
		Plinth equipped with a fine mesh grille	EXS5D90N4...C22N4	VW3 AE 0812	2.000
			EXS5C25N4, C31N4	VW3 AE 0813	3.000
EXS5C40N4, C50N4	VW3 AE 0814		4.000		
EXS5C63N4	VW3 AE 0815		5.000		

(1) For any other configuration, please consult your Regional Sales Office.

(2) The options depend on the rating of the drive and may lead to modification of the size of the enclosure.

(3) Option not compatible with the "Sinus filter" option.

## Variable speed drives

## Altivar 61

IP 54 floor-standing enclosure with separate air flows

Options dependent on the drive rating

## Options dependent on the drive rating (continued) (1)

## Three-phase supply voltage 380...415 V 50/60 Hz (continued)

Description	Use	For ATV 61 enclosure	Reference (2)	Weight kg
Air conditioning	Without motor choke	EXS5D90N4, C11N4	VW3 AE 0901	29.500
		EXS5C13N4	VW3 AE 0902	29.500
		EXS5C16N4	VW3 AE 0903	26.500
		EXS5C22N4	VW3 AE 0904	53.000
		EXS5C25N4, C31N4	VW3 AE 0905	68.000
		EXS5C40N4	VW3 AE 0906	68.000
		EXS5C50N4	VW3 AE 0907	68.000
		EXS5C63N4	VW3 AE 0908	83.000
	With motor choke	EXS5D90N4	VW3 AE 0909	53.000
		EXS5C11N4	VW3 AE 0910	53.000
		EXS5C13N4	VW3 AE 0911	53.000
		EXS5C16N4	VW3 AE 0913	53.000
		EXS5C22N4	VW3 AE 0914	68.000
		EXS5C25N4, C31N4	VW3 AE 0915	68.000
		EXS5C40N4	VW3 AE 0916	65.000
		EXS5C50N4	VW3 AE 0917	80.000
		EXS5C63N4	VW3 AE 0918	80.000

(1) For any other configuration, please consult your Regional Sales Office.

(2) The options depend on the rating of the drive and may lead to modification of the size of the enclosure.

## Variable speed drives

## Altivar 61

IP 54 floor-standing enclosure with separate air flows

Options dependent on the drive rating

Options dependent on the drive rating (continued) (1)					
Three-phase supply voltage 500 V and 600...690 V 50/60 Hz (continued)					
Description	Use	For ATV 61 enclosure		Reference (2)	Weight kg
		500 V	600...690 V		
Resistance braking unit	–	EXS5C20N...C31N	EXS5C25Y...C40Y	VW3 A7E 103 (3)	205.000
		EXS5C40N...C63N	EXS5C50Y...C80Y	VW3 A7E 104 (3)	205.000
Isolating handle for switch	–	EXS5D90N...C16N	EXS5C11Y...C20Y	VW3 AE 0103	1.000
		EXS5C20N...C31N	EXS5C25Y...C40Y	VW3 AE 0104	2.000
		EXS5C40N...C63N	EXS5C50Y...C80Y	VW3 AE 0105	2.000
Ammeter	–	–	EXS5C11Y	VW3 AE 0403	0.200
		EXS5D90N, C11N	EXS5C13Y, C16Y	VW3 AE 0404	0.200
		EXS5C13N, C16N	EXS5C20Y	VW3 AE 0405	0.200
		EXS5C20N	EXS5C25Y, C31Y	VW3 AE 0406	0.200
		EXS5C25N	EXS5C40Y	VW3 AE 0407	0.200
		EXS5C31N, C40N	EXS5C50Y, C63Y	VW3 AE 0408	0.200
		EXS5C50N	EXS5C80Y	VW3 AE 0409	0.200
		EXS5C63N	–	VW3 AE 0410	0.200
Enclosure heater	–	EXS5D90N...C31N	EXS5C11Y...C40Y	VW3 AE 0501	0.500
		EXS5C40N...C63N	EXS5C50Y...C80Y	VW3 AE 0502	1.000
Motor choke	–	EXS5D90N, C11N	EXS5C11Y, C13Y	VW3 AE 0603	17.000
		EXS5C13N, C16N	EXS5C16Y, C20Y	VW3 AE 0604	35.000
		EXS5C20N, C25N	EXS5C25Y, C31Y	VW3 AE 0605	64.000
		EXS5C31N	EXS5C40Y	VW3 AE 0606	102.000
		EXS5C40N	EXS5C50Y	VW3 AE 0630	197.000
		EXS5C50N, C63N	EXS5C63Y, C80Y	VW3 AE 0631	234.000
Cable entry via the top	Without motor choke	EXS5D90N...C16N	EXS5C11Y...C20Y	VW3 AE 0732	–
		EXS5C20N...C31N	EXS5C25Y...C40Y	VW3 AE 0733	–
		EXS5C40N...C63N	EXS5C50Y...C80Y	VW3 AE 0734	252.000
	With motor choke	EXS5D90N...C16N	EXS5C11Y...C20Y	VW3 AE 0735	108.000
		EXS5C20N...C31N	EXS5C25Y...C40Y	VW3 AE 0736	126.000
		EXS5C40N...C63N	EXS5C50Y...C80Y	VW3 AE 0737	252.000
Plinth with fine mesh grille	–	EXS5D90N...C16N	EXS5C11Y...C20Y	VW3 AE 0812	2.000
		EXS5C20N...C31N	EXS5C25Y...C40Y	VW3 AE 0813	3.000
		EXS5C40N...C63N	EXS5C50Y...C80Y	VW3 AE 0815	5.000
Air conditioning	Without motor choke	EXS5D90N...C16N	EXS5C11Y...C20Y	VW3 AE 0919	29.500
		EXS5C20N...C31N	EXS5C25Y...C40Y	VW3 AE 0920	56.000
		EXS5C40N...C63N	EXS5C50Y...C80Y	VW3 AE 0921	71.000
	With motor choke	EXS5D90N...C16N	EXS5C11Y...C20Y	VW3 AE 0922	56.000
		EXS5C20N...C31N	EXS5C25Y...C40Y	VW3 AE 0923	71.000
		EXS5C40N, C50N	EXS5C50Y...C63Y	VW3 AE 0924	71.000
EXS5C63N	EXS5C80Y	VW3 AE 0925	86.000		

(1) For any other configuration, please consult your Regional Sales Office.

(2) The options depend on the rating of the drive and may lead to modification of the size of the enclosure.

(3) The technical characteristics of the VW3 A7E 103 and VWVW3 A7E 104 braking units are identical to those of the VW3 A7 103 and VW3 A7 104 braking units (see page 136).

**IP 54 floor-standing enclosure with separate air flows**

ATV 61EXS5D90N4...EXS5C31N4, ATV 61EXS5D90N...EXS5C31N, ATV 61EXS5C11Y...EXS5C40Y

Common side view

Standard floor-standing enclosure

Standard floor-standing enclosure + additional enclosures, according to the configuration

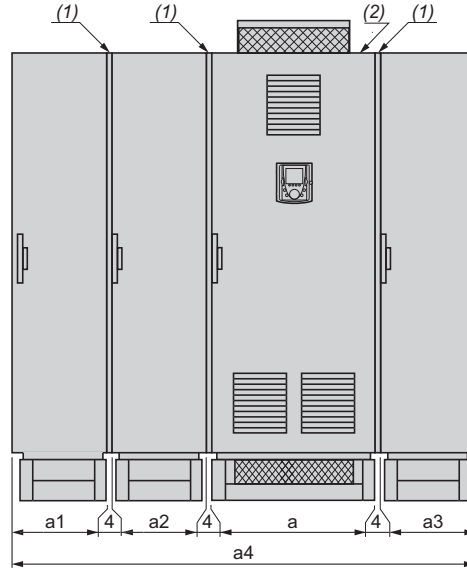
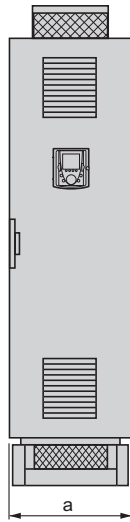
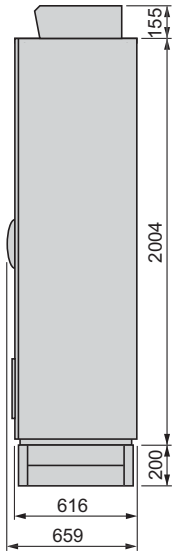

**Note:** Please respect the position of the enclosures during installation. The number of additional enclosures can vary according to the chosen configuration.

ATV 61 enclosures	Options	a	a1	a2	a3	a4
EXS5D90N4...EXS5C16N4	With or without common options or options (3) dependent on the drive rating	616				616
	Cable entry via the top option (4)	608		408		1020
	Sinus filter option	608			608	1220
EXS5C22N4	With or without common options or options (3) dependent on the drive rating	616				616
	Motor choke option	608			408	1020
	Cable entry via the top option (4)	608		408		1020
	Motor choke + cable entry via the top options	600		408	408	1424
	Sinus filter option	608			608	1220
EXS5C25N4...EXS5C31N4	With or without common options or options (3) dependent on the drive rating	816				816
	Cable entry via the top option (4)	808		408		1220
	Sinus filter option	808			608	1420
	Motor choke option	808			408	1220
	Motor choke + cable entry via the top options	800		408	408	1624
EXS5D90N...EXS5C16N, EXS5C11Y...EXS5C20Y	With or without common options or options dependent on the drive rating	608			408	1020
	Cable entry via the top option	608			408	1020
	Cable entry via the top + motor choke options	600		408	408	1424
	With or without common options or options dependent on the drive rating	808			408	1220
EXS5C20N...EXS5C31N, EXS5C25Y...EXS5C40Y	Cable entry via the top option	808			408	1220
	Braking unit option	800		408	408	1624
	Braking unit + cable entry via the top options	800		408	408	1624
	Motor choke + cable entry via the top options	800		408	408	1624
	Motor choke + braking unit + cable entry via the top options	800	408	400	408	2028

(1) Seal. For each additional floor-standing enclosure, allow a 4 mm space for the seal.  
 (2) Standard floor-standing enclosure.  
 (3) Except sinus filter option, which requires an additional enclosure. See table above. The sinus filter option is not compatible with the cable entry via the top option.  
 (4) The cable entry via the top option is not compatible with the sinus filter option.

**IP 54 floor-standing enclosure with separate air flows (continued)**

ATV 61EXS5C40N4...EXS5C63N4, ATV 61EXS5C40N...EXS5C63N, ATV 61EXS5C50Y...EXS5C80Y

Common side view

Standard floor-standing enclosure

Standard floor-standing enclosure + additional enclosures, according to the configuration

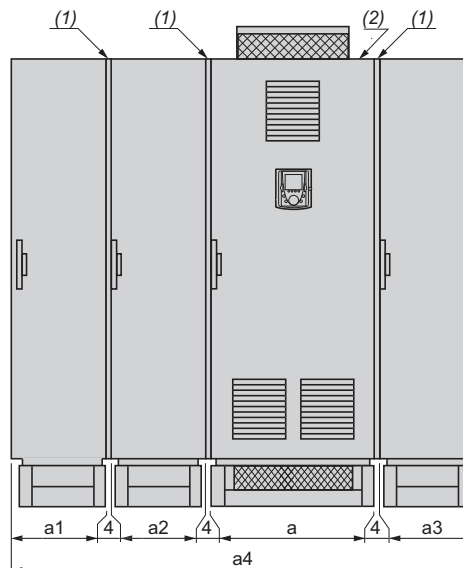
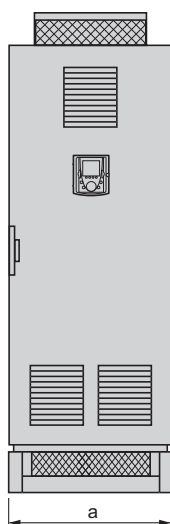
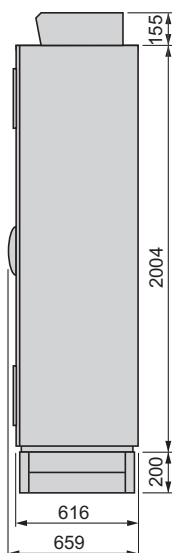

**Note:** Please respect the position of the enclosures during installation. The number of additional enclosures can vary according to the chosen configuration.

ATV 61 enclosures	Options	a	a1	a2	a3	a4
<b>EXS5C40N4</b>	With or without common options or options (3) dependent on the drive rating	1008		408		1420
	Cable entry via the top option (4)	1000		408	408	1824
	Braking unit option only and/or options (3) dependent on rating	1008	408	400		1824
	Braking unit + cable entry via the top options (4)	1000	408	400	408	2228
	Motor choke option	1000		408	408	1824
	Sinus filter option	1000		408	608	2024
<b>EXS5C50N4</b>	With or without common options or options (3) dependent on the drive rating	1008		408		1420
	Cable entry via the top option (4)	1000		408	408	1824
	Braking unit option only and/or options (3) dependent on rating	1008	408	400		1824
	Braking unit + cable entry via the top options (4)	1000	408	400	408	2228
	Motor choke option	1000		408	408	1824
	Sinus filter option	1000		408	808	2224
<b>EXS5C63N4</b>	With or without common options or options (3) dependent on the drive rating	1208		408		1620
	Cable entry via the top option (4)	1200		408	408	2024
	Braking unit option only and/or options (3) dependent on rating	1208	408	400		2024
	Braking unit + cable entry via the top options (4)	1200	408	400	408	2428
	Motor choke option	1200		408	408	2024
	Sinus filter option	1200		408	808	2424
<b>EXS5C40N...EXS5C63N, EXS5C50Y...EXS5C80Y</b>	With or without common options or options dependent on the drive rating	1208		408		1620
	Cable entry via the top option	1200		408	408	2024
	Braking unit option only and/or options (3) dependent on rating	1208	408	400		2024
	Braking unit + cable entry via the top options	1200	408	400	408	2428
	Motor choke option	1200		408	408	2024

(1) Seal. For each additional floor-standing enclosure, allow a 4 mm space for the seal.

(2) Standard floor-standing enclosure.

(3) Except sinus filter option, which requires an additional enclosure. See table above. The sinus filter option is not compatible with the cable entry via the top option.

(4) The cable entry via the top option is not compatible with the sinus filter option.



**IP 54 floor-standing enclosure with separate air flows (continued)**

Air conditioned option VW3 AE 0901...0909, 0911, 0912, 0914...0918, 0919...0925

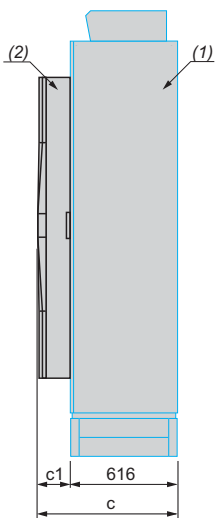

VW3	c	c1
AE 0901...0903	847	231
AE 0904	796	180
AE 0905...0907	856	240
AE 0908	976	360
AE 0909, 0911, 0912	796	180
AE 0914...0916	856	240
AE 0917, 0918	976	360
AE 0919	847	231
AE 0920	796	180
AE 0921	856	240
AE 0922	796	180
AE 0923	796	240
AE 0924	856	240
AE 0925	976	360

(1) IP 54 floor-standing enclosure with separate air flows

(2) Air conditioned option.

### Mounting recommendations

The derating curves for the drive nominal current ( $I_n$ ) are dependent on the temperature and switching frequency. For intermediate temperatures, interpolate between 2 curves.

**Note:** The drive will reduce the switching frequency automatically in the event of excessive temperature rise.

#### Derating curves for ATV 61EXS5D90N4...EXS5C63N4, ATV 61EXS5D90N...EXS5C13N, ATV 61EXS5C11Y...EXS5C16Y (1)

ATV 61EXS5D90N4... EXS5C63N4

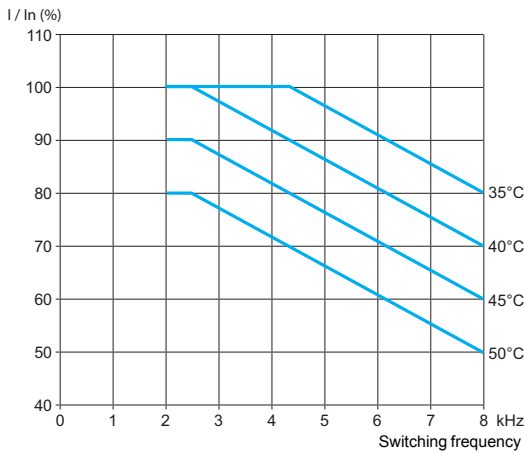

ATV 61EXS5D90N, ATV 61EXS5C11Y

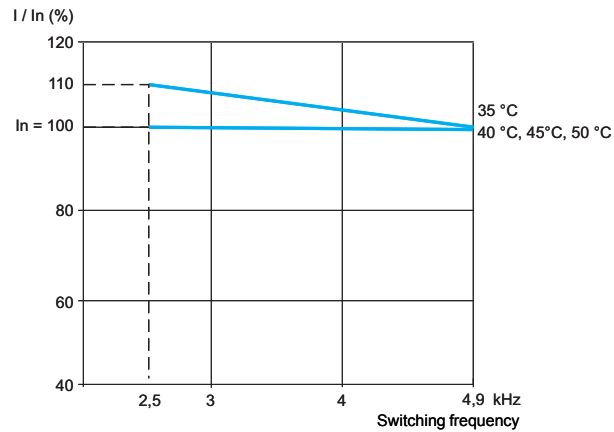

ATV 61EXS5C11N, ATV 61EXS5C13Y

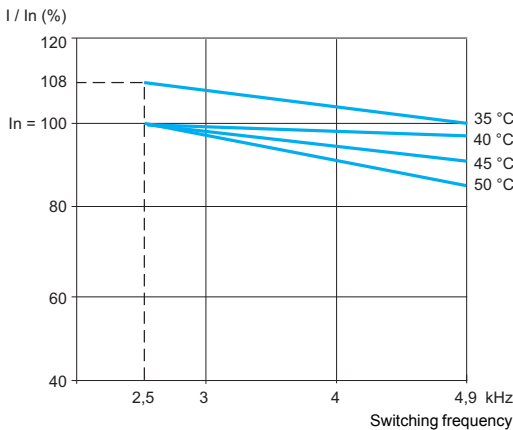

ATV 61EXS5C13N, ATV 61EXS5C16Y

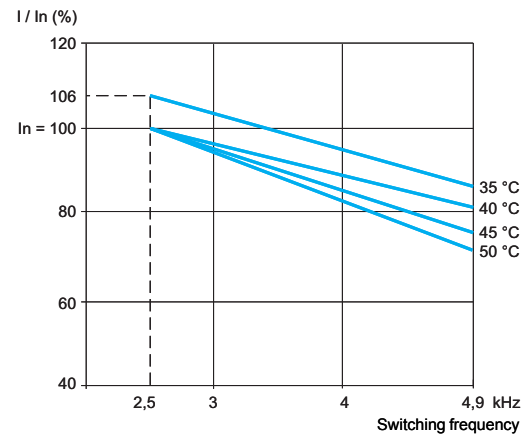

(1) The temperatures shown correspond to the temperature of the air entering the enclosure.

**Derating curves for ATV 61EXS5C16N...EXS5C31N, ATV 61EXS5C20Y...EXS5C40Y (1)**

**ATV 61EXS5C16N, ATV 61EXS5C20Y**

**ATV 61EXS5C20N, ATV 61EXS5C25Y**

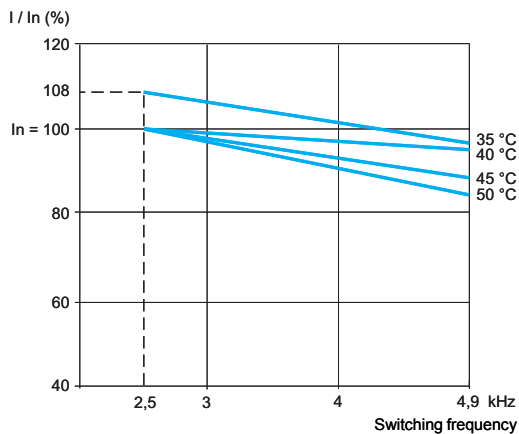
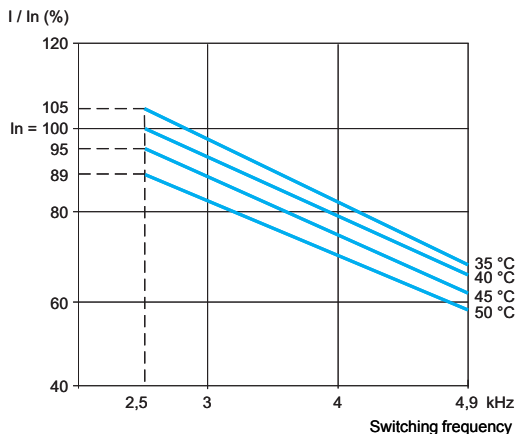

**ATV 61EXS5C25N, ATV 61EXS5C31Y**

**ATV 61EXS5C31N, ATV 61EXS5C40Y**

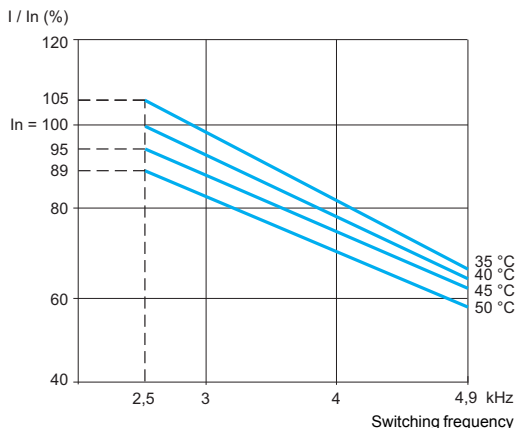
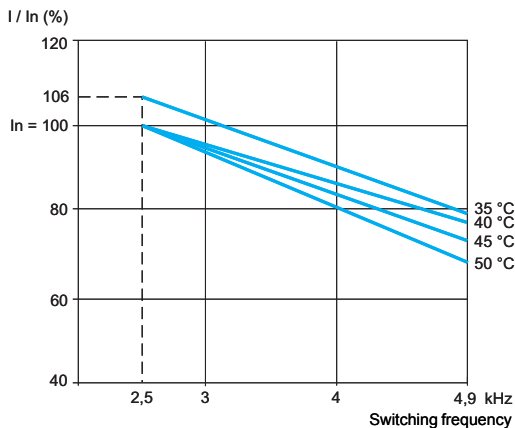

(1) The temperatures shown correspond to the temperature of the air entering the enclosure.

**Derating curves for ATV 61EXS5C40N...EXS5C63N, ATV 61EXS5C50Y...EXS5C80Y (1)**

**ATV 61EXS5C40N, ATV 61EXS5C50Y**

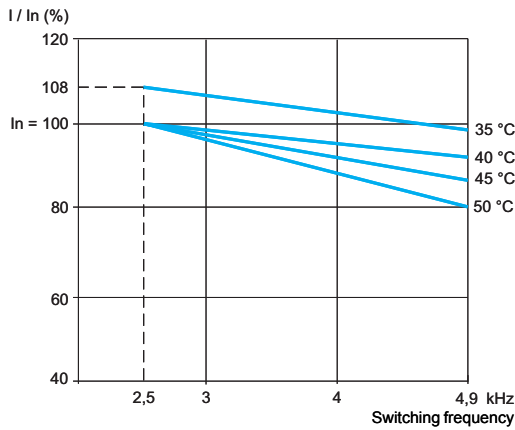

**ATV 61EXS5C50N, ATV 61EXS5C63Y**

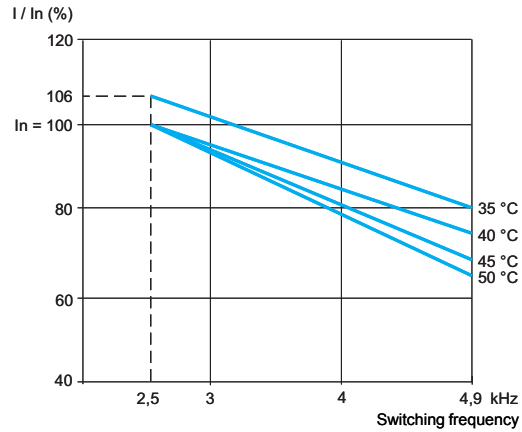

**ATV 61EXS5C63N, ATV 61EXS5C80Y**

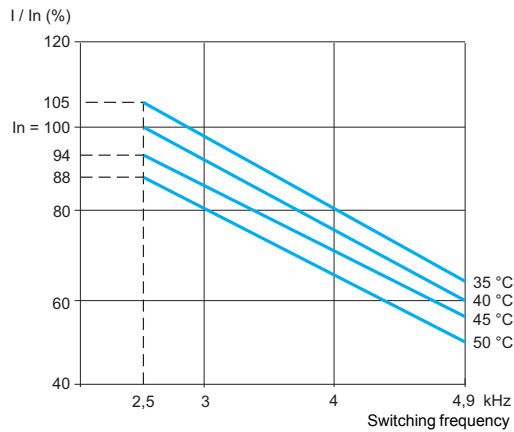

(1) The temperatures shown correspond to the temperature of the air entering the enclosure.

### IP 54 floor-standing enclosure with separate air flows

ATV 61EXS5D90N4...EXS5C40N4, ATV 61EXS5D90N...EXS5C31N, ATV 61EXS5C11Y...EXS5C40Y

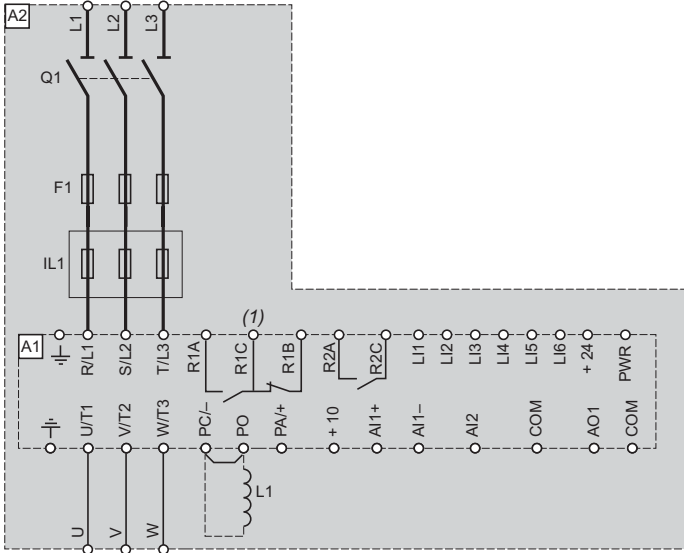

Ref.	Description
A1	ATV 61 drive (see pages 20 and 23)
A2	ATV 61EXS5, IP 54 floor-standing enclosure with separate air flows (see page 84)
F1	Fast-acting semi-conductor fuse
IL1	Line choke for ATV 61EXS5●●●N and ATV 61EXS5●●●Y drives
L1	DC choke for ATV 61EXS5●●●N4 drives
Q1	Switch

### ATV 61EXS5C50N4, EXS5C63N4, ATV 61EXS5C40N...EXS5C63N, ATV 61EXS5C50Y...EXS5C80Y

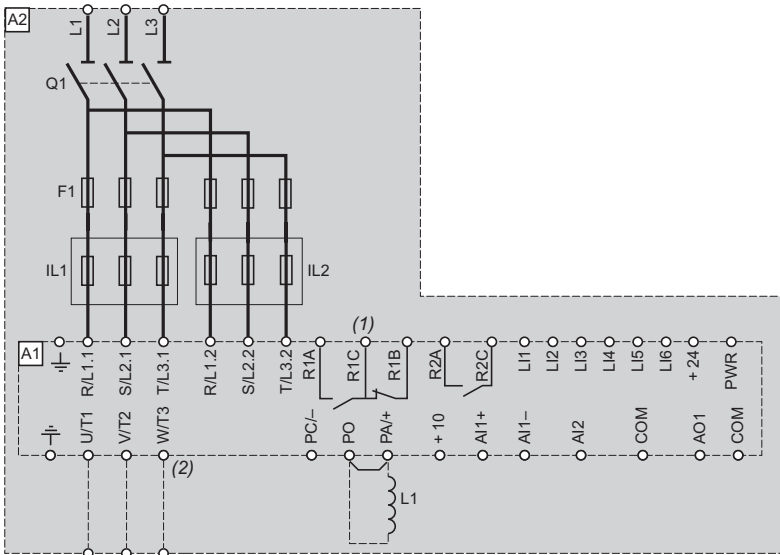

Ref.	Description
A1	ATV 61 drive (see pages 20 and 23)
A2	ATV 61EXS5, IP 54 floor-standing enclosure with separate air flows (see page 84)
F1	Fast-acting semi-conductor fuse
IL1, IL2	Line chokes for ATV 61EXS5●●●N and ATV 61EXS5●●●Y drives
L1	DC choke for ATV 61EXS5●●●N4 drives
Q1	Switch

(1) Fault relay contacts. For remote signalling of drive status.

(2) For ATV 61EXS5●●●N and ATV 61EXS5●●●Y drives only.

### Options common to all drives

#### Remote control terminals X12 - VW3 AE 1201

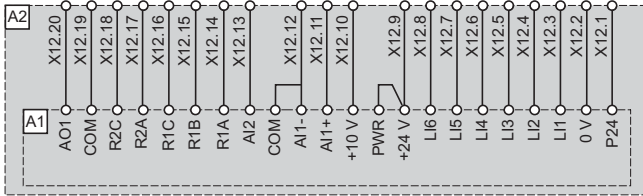

Ref.	Description
A1	ATV 61 drive (see pages 20 and 23)
A2	ATV 61EXS5, IP 54 floor-standing enclosure with separate air flows (see page 84)

#### Remote option card terminals X13 - VW3 AE 1202

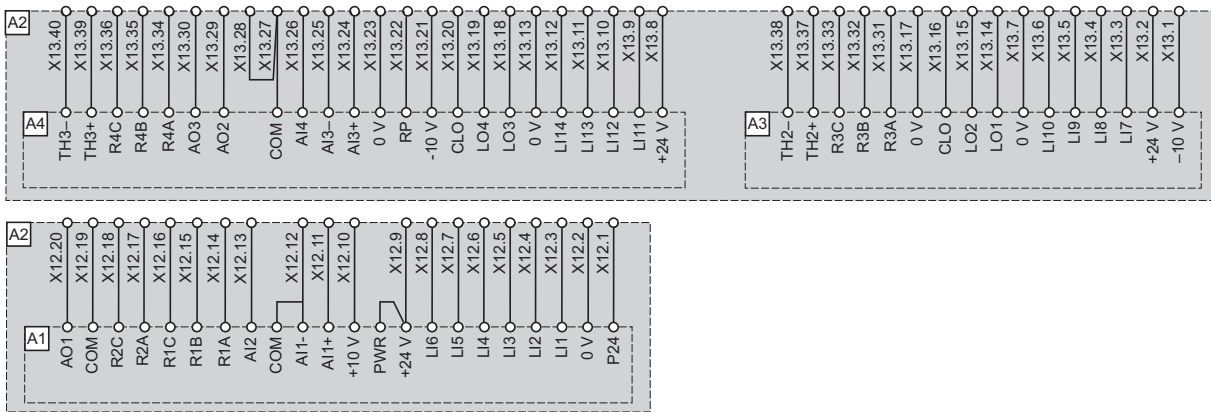

Ref.	Description
A1	ATV 61 drive (see pages 20 and 23)
A2	ATV 61EXS5, IP 54 floor-standing enclosure with separate air flows (see page 84)
A3	I/O option card VW3 A3E 201 (see page 85)
A4	I/O option card VW3 A3E 202 (see page 85)

### Options common to all drives (continued)

#### External 230 V ~ supply terminals - VW3 AE 1301

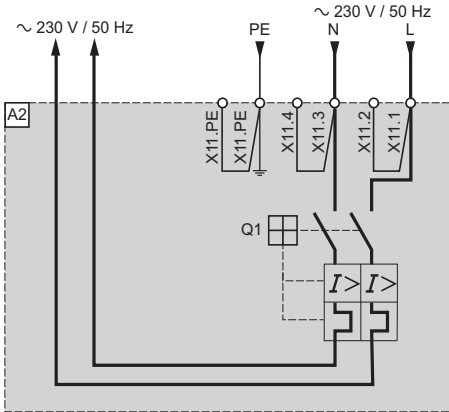

Ref.	Description
A2	ATV 61EXS5, IP 54 floor-standing enclosure with separate air flows (see page 84)
Q1	6 A circuit-breaker
X11	External 230 V ~ supply terminals

#### Additional 24 V DC power supply - VW3 AE 1401

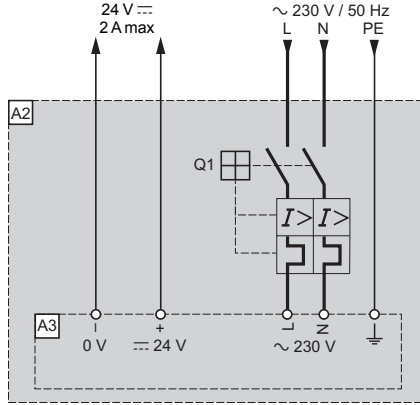

Ref.	Description
A2	ATV 61EXS5, IP 54 floor-standing enclosure with separate air flows (see page 84)
A3	Additional 24 V DC power supply
Q1	2 A circuit-breaker

#### External 24 V DC supply terminals - VW3 AE 1402

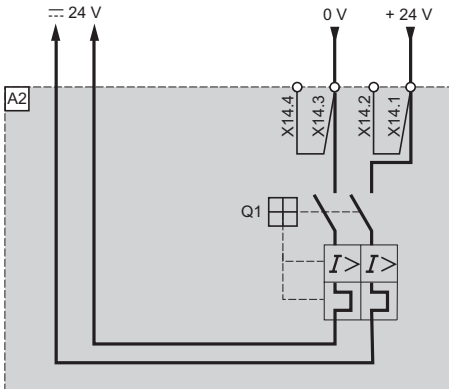

Ref.	Description
A2	ATV 61EXS5, IP 54 floor-standing enclosure with separate air flows (see page 84)
Q1	2 A circuit-breaker
X14	External 24 V DC supply terminals

### Options common to all drives (continued)

#### Emergency stop button - VW3 AE 1501

Scheme conforming to standards EN 954-1 category 1, IEC/EN 61508 capacity SIL1, stopping category 0 in accordance with IEC/EN 60204-1

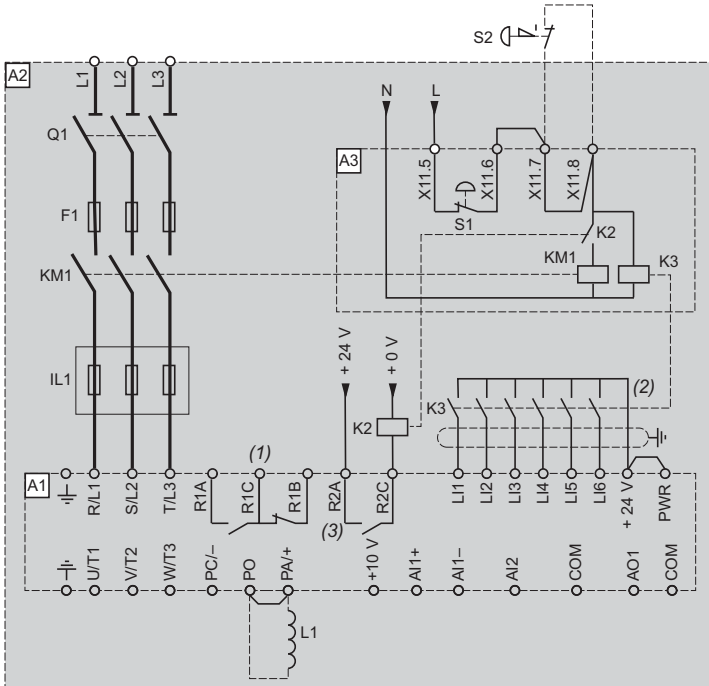

Ref.	Description
A1	ATV 61 drives (see pages 20 and 23)
A2	ATV 61EXS5, IP 54 floor-standing enclosure with separate air flows (see page 84)
A3	Emergency stop button
IL1	Line choke for ATV 61EXS5●●●N and ATV 61EXS5●●●Y drives
K2	Line contactor control contactor
K3	Logic input control contactor
KM1	Line contactor
L1	DC choke for ATV 61EXS5●●●N4 drives
Q1	Switch
S1	Emergency stop button mounted on enclosure door
S2	Emergency stop button

(1) Fault relay contacts. For remote signalling of drive status.

(2) Connection of the common for the logic inputs depends on the positioning of the SW1 switch: see schemes on page 214.

(3) Relay logic output R2A must be assigned to the "Line contactor" parameter.



### Options common to all drives (continued)

#### "Preventa type AC" fault relay - VW3 AE 1502

Scheme conforming to standards EN 954-1 category 3, IEC/EN 61508 capacity SIL2, stopping category 0 in accordance with IEC/EN 60204-1

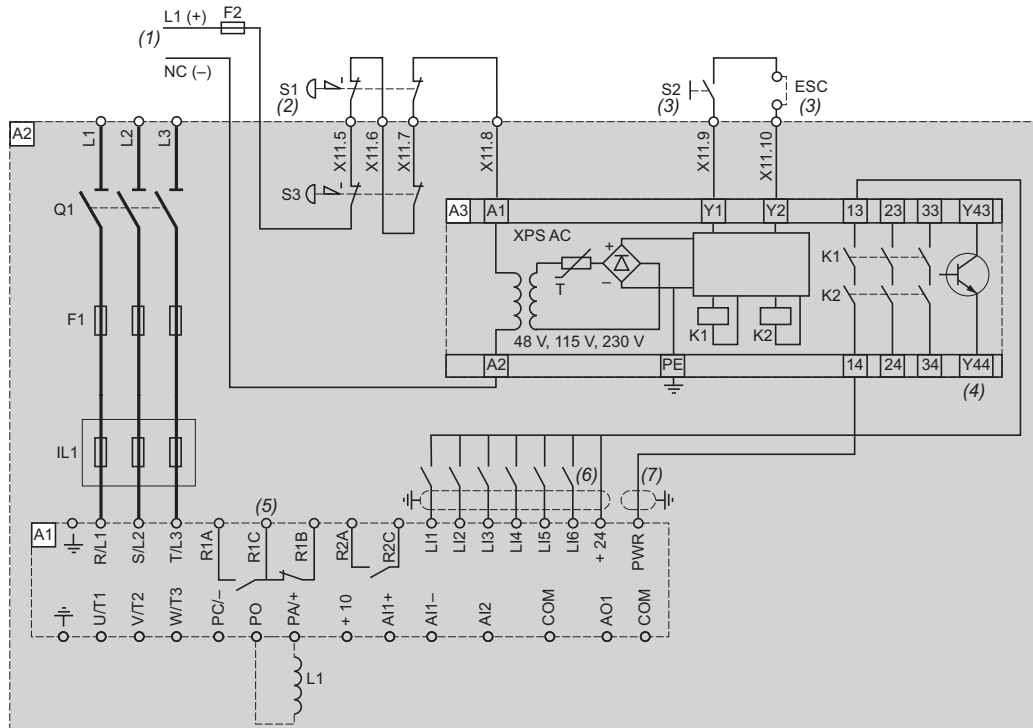

Ref.	Description
A1	ATV 61 drive (see pages 20 and 23)
A2	ATV 61EXS5, IP 54 floor-standing enclosure with separate air flows (see page 84)
A3	Preventa XPS AC safety module for monitoring emergency stops and switches. One safety module can manage the "Power Removal" function for several drives on the same machine. In this case, the PWR terminal on each drive must be connected to the + 24 V via the safety contacts on the XPS AC module. These contacts are independent for each drive.
F1	Fast-acting semi-conductor fuse
F2	Fuse
IL1	Line choke for ATV 61EXS5●●●N and ATV 61EXS5●●●Y drives
L1	DC choke for ATV 61EXS5●●●N4 drives
Q1	Switch
S1	Emergency stop button with 2 contacts
S2	XB4 B or XB5 A pushbutton
S3	Emergency stop button with 2 contacts, mounted on enclosure door

(1) Power supply: 24 V  $\bar{\bar{}}$ , 230 V  $\sim$ .

(2) Requests freewheel stopping of the movement and activates the "Power Removal" safety function.

(3) S2: resets the XPS AC module on power-up or after an emergency stop. ESC can be used to set external starting conditions.

(4) The logic output can be used to indicate that the machine is in a safe stop state.

(5) Fault relay contacts. For remote signalling of drive status.

(6) Connection of the common for the logic inputs depends on the positioning of the SW1 switch: see schemes on page 214.

(7) Standardized coaxial cable, type RG174/U according to MIL-C17 or KX3B according to NF C 93-550, external diameter 2.54 mm, maximum length 15 m. The cable shielding must be earthed.

#### Options common to all drives (continued)

#### "Preventa type ATE" fault relay - VW3 AE 1503

Scheme conforming to standards EN 954-1 category 3, IEC/EN 61508 capacity SIL 2, stopping category 1 in accordance with IEC/EN 60204-1

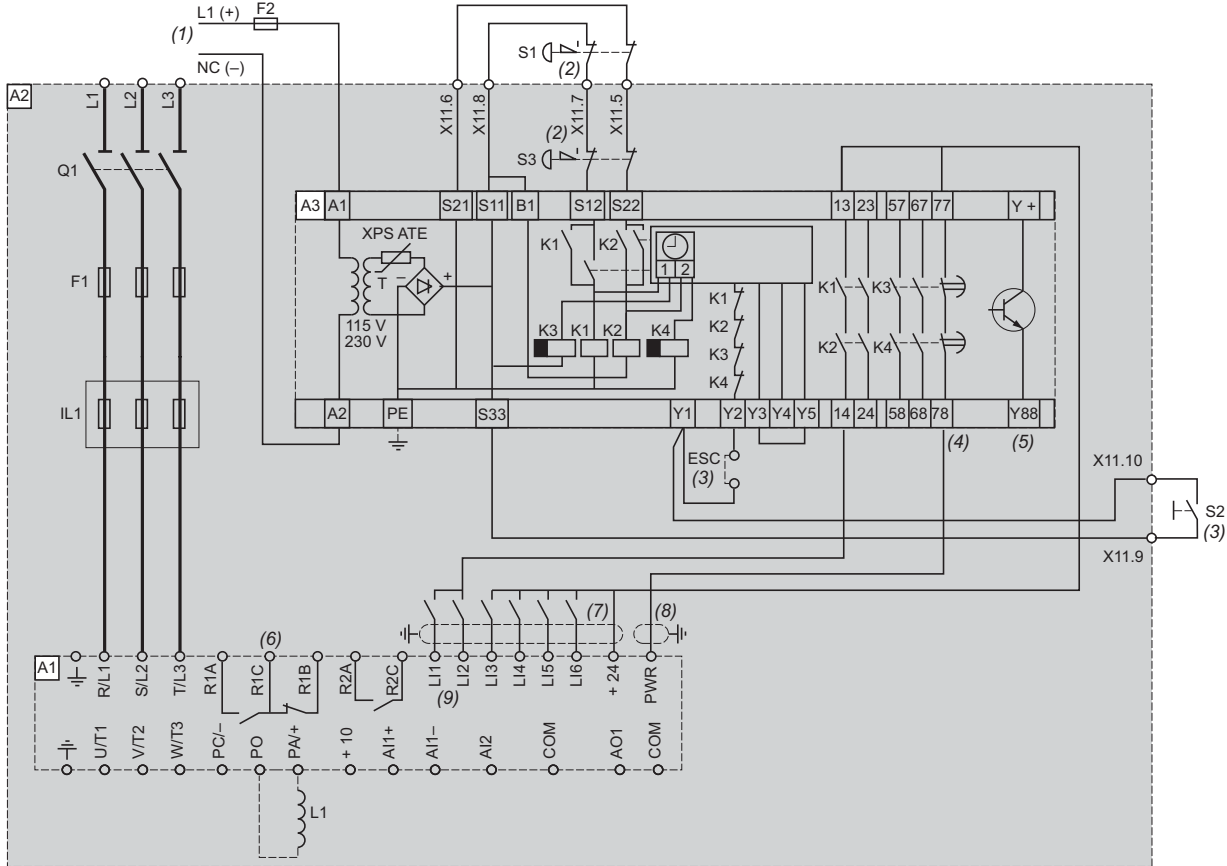

Ref.	Description
A1	ATV 61 drive (see pages 20 and 23)
A2	ATV 61EXS5, IP 54 floor-standing enclosure with separate air flows (see page 84)
A3	Preventa XPS ATE safety module for monitoring emergency stops and switches. One safety module can manage the "Power Removal" safety function for several drives on the same machine. In this case the time delay must be adjusted on the drive controlling the motor that requires the longest stopping time. In addition, the PWR terminal on each drive must be connected to the + 24 V via the safety contacts on the XPS ATE module. These contacts are independent for each drive.
F1	Fast-acting semi-conductor fuse
F2	Fuse
IL1	Line choke for ATV 61EXS5●●●N and ATV 61EXS5●●●Y drives
L1	DC choke for ATV 61EXS5●●●N4 drives
Q1	Switch
S1	Emergency stop button with 2 contacts
S2	Run button
S3	Emergency stop button with 2 contacts, mounted on enclosure door

(1) Power supply: 24 V  $\overline{\text{---}}$ , 230 V  $\sim$ .

(2) Requests controlled stopping of the movement and activates the "Power Removal" safety function.

(3) S2: resets the XPS ATE module on power-up or after an emergency stop. ESC can be used to set external starting conditions.

(4) For stopping times requiring more than 30 seconds in category 1, use a Preventa XPS AV safety module which can provide a maximum time delay of 300 seconds.

(5) The logic output can be used to indicate that the machine is in a safe state.

(6) Fault relay contacts. For remote signalling of drive status.

(7) Connection of the common for the logic inputs depends on the positioning of the SW1 switch: see schemes on page 214.

(8) Standardized coaxial cable, type RG174/U according to MIL-C17 or KX3B according to NF C 93-550, external diameter 2.54 mm, maximum length 15 m. The cable shielding must be earthed.

(9) Logic inputs LI1 and LI2 must be assigned to the direction of rotation: LI1 to forward direction and LI2 to reverse direction.

#### Options common to all drives (continued)

##### Enclosure lighting - VW3 AE 1601

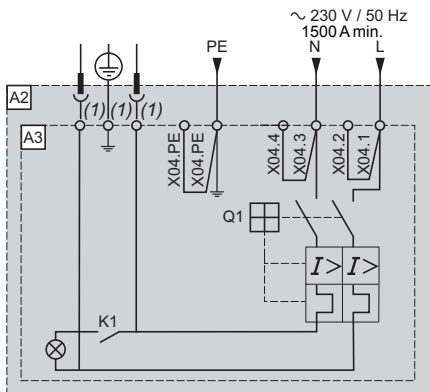

Ref.	Description
A2	ATV 61EXS5, IP 54 floor-standing enclosure with separate air flows (see page 84)
A3	Enclosure lighting
K1	Door contact
Q1	6 A circuit-breaker

(1) European standard power socket available.

##### Additional electrical input isolation - VW3 AE 1901

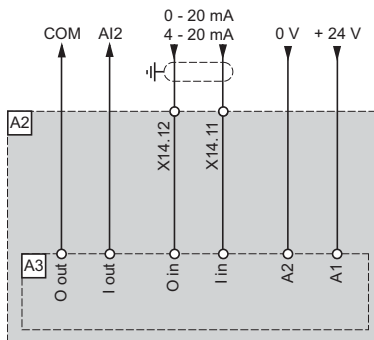

Ref.	Description
A2	ATV 61EXS5, IP 54 floor-standing enclosure with separate air flows (see page 84)
A3	Additional electrical input isolation

##### Additional electrical output isolation - VW3 AE 1902

###### AO1 analog output option

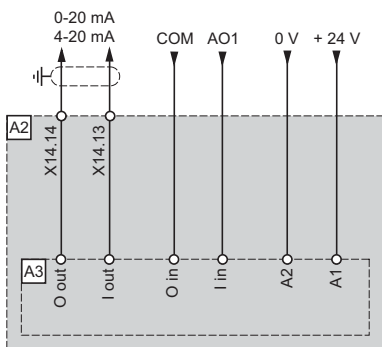

Ref.	Description
A2	ATV 61EXS5, IP 54 floor-standing enclosure with separate air flows (see page 84)
A3	Additional electrical output isolation

###### AO2 analog output option

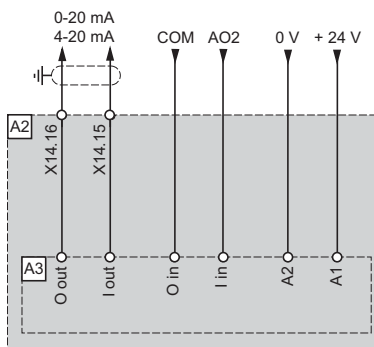

Ref.	Description
A2	ATV 61EXS5, IP 54 floor-standing enclosure with separate air flows (see page 84)
A3	Additional electrical output isolation

###### AO3 analog output option

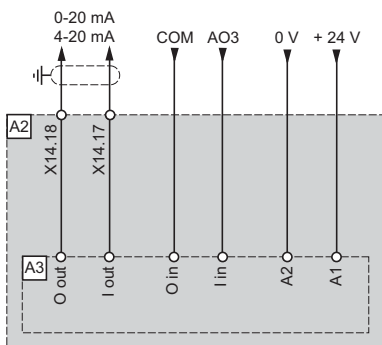

Ref.	Description
A2	ATV 61EXS5, IP 54 floor-standing enclosure with separate air flows (see page 84)
A3	Additional electrical output isolation

#### Options common to all drives (continued)

##### PTC relay - VW3 AE 2001

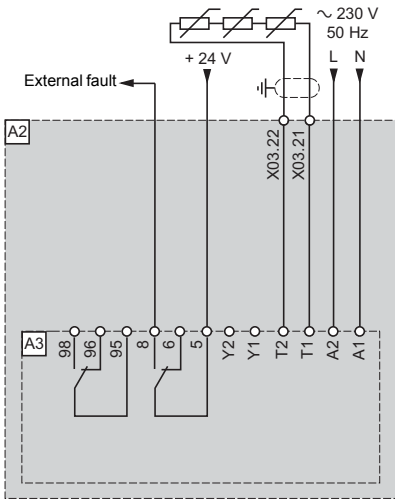

Ref.	Description
A2	ATV 61EXS5, IP 54 floor-standing enclosure with separate air flows (see page 84)
A3	PTC relay

##### PTC relay with PTB (ATEX) certification (1) - VW3 AE 2002

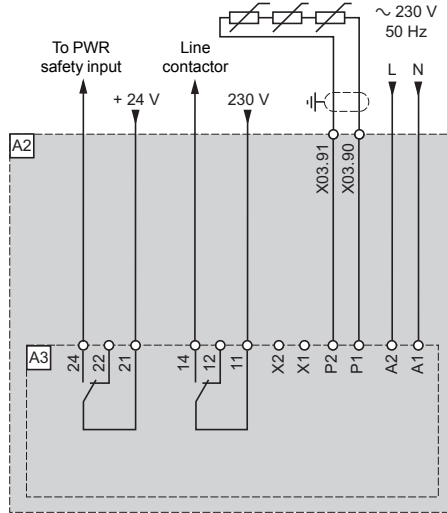

Ref.	Description
A2	ATV 61EXS5, IP 54 floor-standing enclosure with separate air flows (see page 84)
A3	PTC relay with PTB (ATEX) certification

(1) ATEX: see pages 208 and 209

##### Relay for PT100 for motor winding - VW3 AE 2003

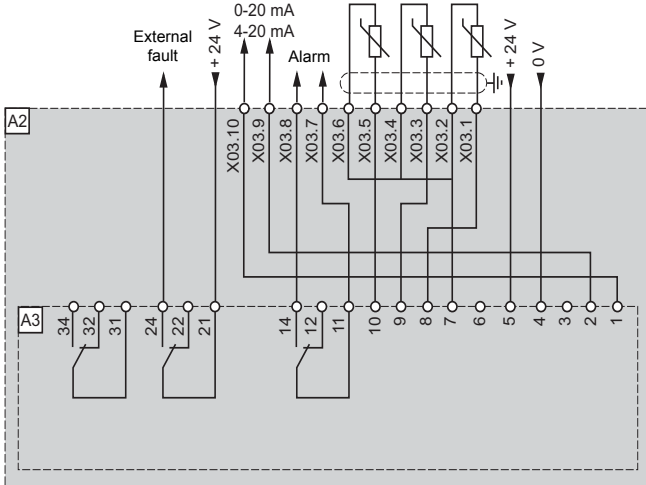

Ref.	Description
A2	ATV 61EXS5, IP 54 floor-standing enclosure with separate air flows (see page 84)
A3	PT100 relay for motor winding

##### PT100 relay for motor bearings - VW3 AE 2004

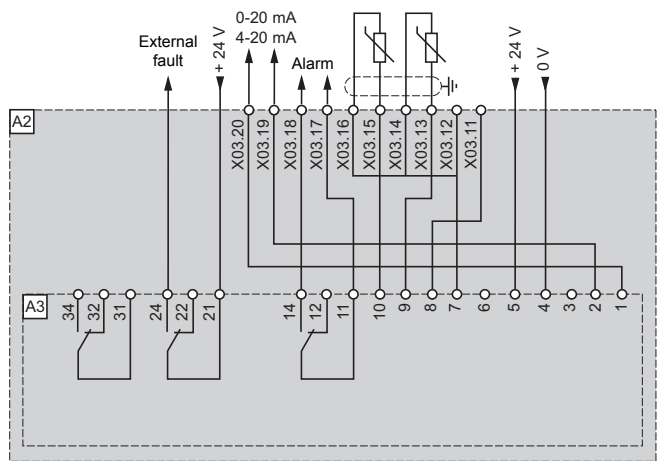

Ref.	Description
A2	ATV 61EXS5, IP 54 floor-standing enclosure with separate air flows (see page 84)
A3	PT100 relay for motor bearings

#### Options common to all drives (continued)

##### Motor heater - VW3 AE 2101

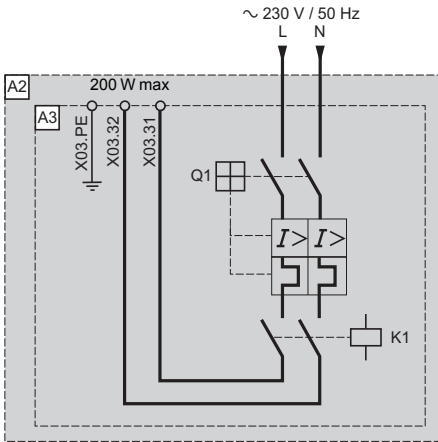

Ref.	Description
A2	ATV 61EXS5, IP 54 floor-standing enclosure with separate air flows (see page 84)
A3	Motor heater
K1	Controlled by the drive or the line contactor. This control is activated if the drive is at "Stop" state
Q1	Circuit-breaker

##### Power supply circuit with protection for external fan - VW3 AE 2102

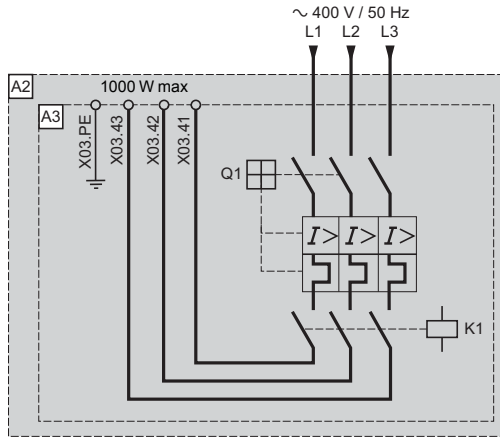

Ref.	Description
A2	ATV 61EXS5, IP 54 floor-standing enclosure with separate air flows (see page 84)
A3	Power supply circuit with protection
K1	Controlled by the drive or the line contactor. This control is activated if the drive is at "RUN" state
Q1	Circuit-breaker

##### Relay for logic output - VW3 AE 2201

###### Logic output LO1

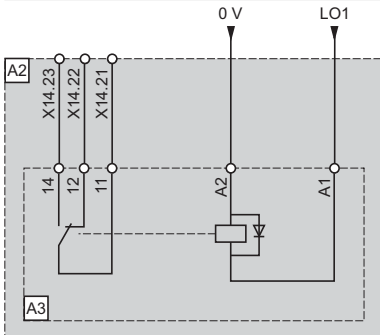

Ref.	Description
A2	ATV 61EXS5, IP 54 floor-standing enclosure with separate air flows (see page 84)
A3	Relay for logic output

###### Logic output LO2

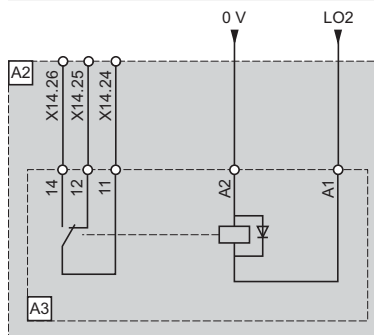

Ref.	Description
A2	ATV 61EXS5, IP 54 floor-standing enclosure with separate air flows (see page 84)
A3	Relay for logic output

###### Logic output LO3

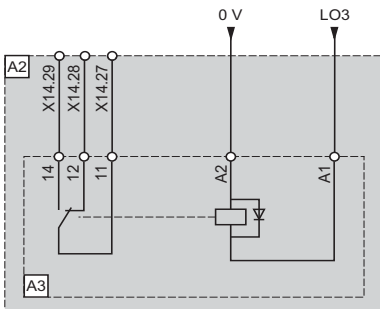

Ref.	Description
A2	ATV 61EXS5, IP 54 floor-standing enclosure with separate air flows (see page 84)
A3	Relay for logic output

###### Logic output LO4

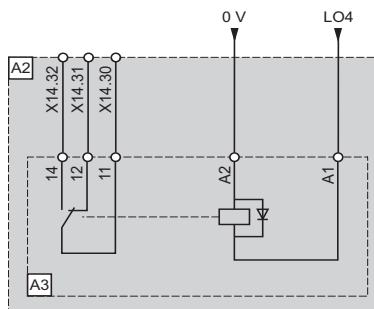

Ref.	Description
A2	ATV 61EXS5, IP 54 floor-standing enclosure with separate air flows (see page 84)
A3	Relay for logic output

### Options dependent on the drive rating

#### Braking units - VW3 A7E 101...104

ATV 61EXS5C25N4...C63N4, ATV 61EXS5C20N...C63N and ATV 61EXS5C25Y...C80Y

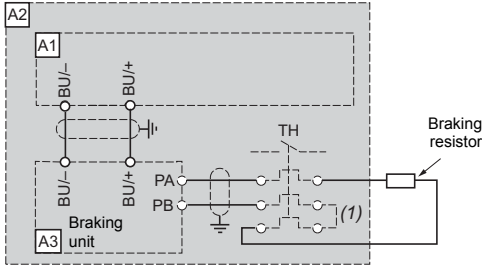

Ref.	Description
A1	ATV 61 drive (see pages 20 and 23)
A2	ATV 61EXS5, IP 54 floor-standing enclosure with separate air flows (see page 84)
A3	Braking unit (see pages 87 and 91)
<b>Braking resistor</b>	See pages 140 and 141

(1) A thermal overload relay can be added. The contact on this relay must then be integrated in the control circuit.

#### 500 VA or 800 VA ~ control transformers - VW3 AE 0302, VW3 AE 0303

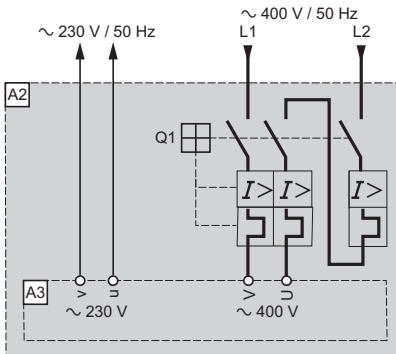

Ref.	Description
A2	ATV 61EXS5D90N4...C63N4, IP 54 floor-standing enclosure with separate air flows (see page 84)
A3	500 VA ~ or 800 VA ~ control transformer (see page 88)
Q1	Circuit-breaker

#### Air conditioning - VW3 AE 0901...0918

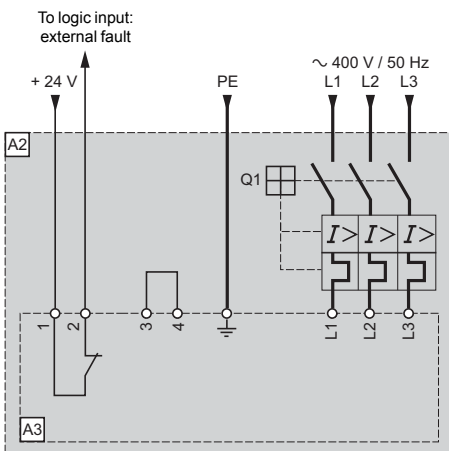

Ref.	Description
A2	ATV 61EXS5●●●●●, IP 54 floor-standing enclosure with separate air flows (see page 84)
A3	Air conditioning (see page 90)
Q1	Circuit-breaker

107486

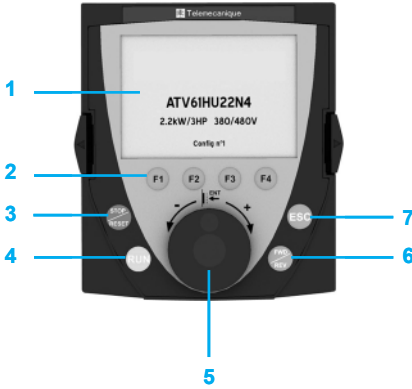

### Remote graphic display terminal

(This terminal can be supplied with the drive or ordered separately)

This display terminal is attached to the front of the drive. It includes the integrated 7-segment display terminal for drives supplied without a graphic display terminal or for ATV 61H●●●Y drives.

It can be:

- Used remotely in conjunction with the appropriate accessories (see below)
- Connected to several drives using multidrop link components (see page 109)

It is used:

- To control, adjust and configure the drive
- To display the current values (motor, input/output values, etc.)
- To save and download configurations; 4 configuration files can be saved

The terminal's maximum operating temperature is 60°C and it features IP 54 protection.

#### Description

- 1 Graphic display:
  - 8 lines, 240 x 160 pixels
  - Large digits that can be read from 5 m away
  - Supports display of bar charts
- 2 Assignable function keys F1, F2, F3, F4:
  - Dialogue functions: Direct access, help screens, navigation
  - Application functions: "Local/Remote", preset speed
- 3 "STOP/RESET" key: Local control of motor stop/fault reset
- 4 "RUN" key: Local control of motor operation
- 5 Navigation button:
  - Press: Saves the current value (ENT)
  - Turn ±: Increases or decreases the value, or goes to the next or previous line
- 6 "FWD/REV" key: Reverses the direction of rotation of the motor
- 7 "ESC" key: Aborts a value, a parameter or a menu to return to the previous selection

*Note: Keys 3, 4 and 6 can be used to control the drive directly.*

#### Reference

Description	No.	Reference	Weight kg
Remote graphic display terminal	1	VW3 A1 101	0.145

### Remote graphic display terminal accessories

The following accessories are available:

- A remote mounting kit for mounting on an enclosure door with IP 54 degree of protection, including:
  - All the mechanical fittings
  - Fixing accessories
- A transparent door which attaches to the remote mounting mechanism to achieve IP 65 degree of protection
- A preassembled cordset with two RJ45 connectors so that the graphic display terminal can be connected to the Altivar 61 drive (1, 3, 5 or 10 m cable lengths available)
- A female/female RJ45 adaptor for connecting the graphic display terminal VW3 A1 101 to the remote-mounting cordset VW3 A1 104 R●●●.

#### References

Description	No.	Length m	Degree of protection	Reference	Weight kg
Remote mounting kit (1)	2	-	IP 54	VW3 A1 102	0.150
Door (2)	3	-	IP 65	VW3 A1 103	0.040
Remote-mounting cordsets with 2 RJ45 connectors	4	1	-	VW3 A1 104 R10	0.050
	4	3	-	VW3 A1 104 R30	0.150
	4	5	-	VW3 A1 104 R50	0.250
	4	10	-	VW3 A1 104 R100	0.500
Female/female RJ45 adaptor	5	-	-	VW3 A1 105	0.010

(1) In this case, use a VW3 A1 104 R●●● remote-mounting cordset, to be ordered separately (see above).

(2) To be mounted on remote mounting kit VW3 A1 102 (for mounting on an enclosure door), which must be ordered separately (see above).

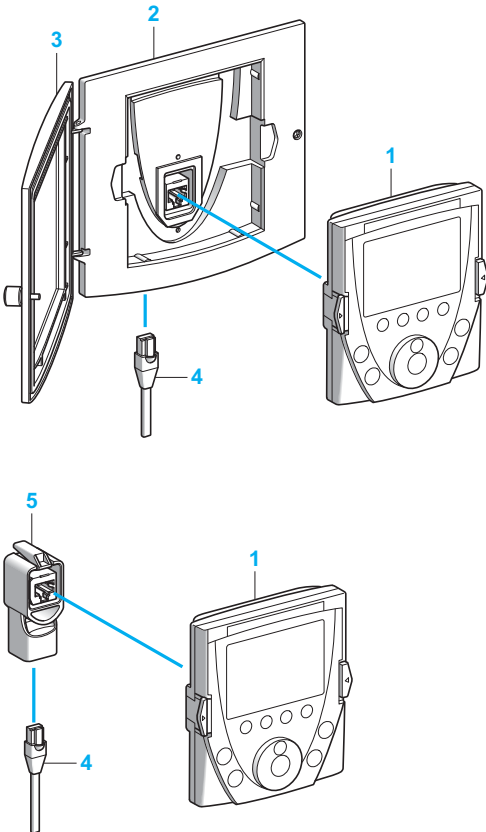

## Variable speed drives

Altivar 61

Options: dialogue

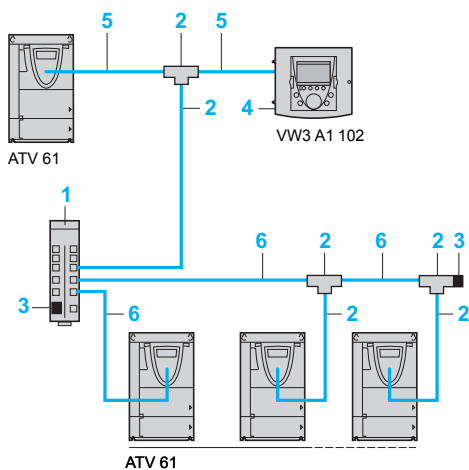

Example of connection via multidrop link

537165

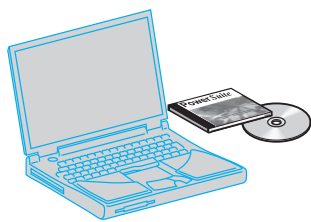

PowerSuite software workshop

## Multidrop link components

These components enable a graphic display terminal to be connected to several drives via a multidrop link. This multidrop link is connected to the Modbus terminal port on the front of the drive.

## Connection accessories

Description	No.	Sold in lots of	Unit reference	Weight kg
<b>Modbus splitter box</b> 10 RJ45 connectors and 1 screw terminal block	1	–	LU9 GC3	0.500
<b>Modbus T-junction boxes</b> With integrated cable (0.3 m)	2	–	VW3 A8 306 TF03	–
With integrated cable (1 m)	2	–	VW3 A8 306 TF10	–
<b>Modbus line terminator</b> For RJ45 connector	3	2	VW3 A8 306 RC	0.010
<b>Remote mounting kit</b> For graphic display terminal VW3 A1 101	4	–	VW3 A1 102	0.150

Cordsets  
(equipped with 2 RJ45 connectors)

Used for	No.	Length m	Reference	Weight kg
<b>Remote operation of the Altivar 61 and the graphic display terminal VW3 A1 101</b>	5	1	VW3 A1 104 R10	0.050
	3		VW3 A1 104 R30	0.150
	5		VW3 A1 104 R50	0.250
	10		VW3 A1 104 R100	0.500
	<b>Modbus serial link</b>	6	0.3	VW3 A8 306 R03
		1	VW3 A8 306 R10	0.060
		3	VW3 A8 306 R30	0.130

## PowerSuite software workshop

The PowerSuite software workshop offers the following benefits:

- Messages can be displayed in plain text in several languages (English, French, German, Italian and Spanish)
- Work can be prepared in the design office without having to connect the drive to the PC
- Configurations and settings can be saved to floppy disk, hard disk and downloaded to the drive
- Print facility
- Oscillograms can be displayed

See pages 284 to 287.



### Presentation

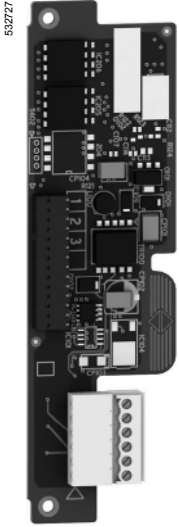

VW3 A3 401

Encoder interface cards are used for application safety, irrespective of the control type:

- Overspeed detection
- Load slipping detection

Three types of card are available depending on the encoder technology:

- RS 422 compatible differential outputs
- Open collector outputs (NPN)
- Push-pull outputs

The card is inserted into a dedicated slot.

### Characteristics

#### Encoder interface cards with RS 422 compatible differential outputs

Type of card		<b>VW3 A3 401</b>	
Power supply (supplied by the card)	Voltage	5 V $\overline{\text{---}}$ (min. 5 V, max. 5.5 V)	
	Maximum current	200 mA	
		Short-circuit and overload protection	
Maximum cable length		50 m	
Maximum operating frequency		300 kHz	
Input signals		A, $\bar{A}$ , B, $\bar{B}$	
	Impedance	440 $\Omega$	
Number of pulses/encoder revolution		5000 maximum The maximum high-speed frequency should not exceed 300 kHz.	
Encoder consumption		<b>100 mA at 4.5 V</b>	<b>200 mA at 4.5 V</b>
Minimum cross-section recommended for the conductors (1)	For a maximum cable length of 25 m	0.2 mm <sup>2</sup> (AWG 24)	0.5 mm <sup>2</sup> (AWG 20)
	For a maximum cable length of 50 m	0.5 mm <sup>2</sup> (AWG 20)	0.75 mm <sup>2</sup> (AWG 18)
Type of encoder		<b>XCC 1●●●●●●X, R, RN (2)</b>	<b>XCC 1●●●●●●X (2)</b>

(1) Shielded cable containing 3 twisted pairs at intervals of between 20 and 50 mm. Connect the shielding to earth at both ends.

Minimum recommended conductor cross-section for a minimum encoder voltage in order to limit line voltage drops.

(2) To obtain the complete encoder reference, please refer to the "Global Detection - Electronic and Electromechanical Sensors" catalogue or visit our website "www.telemecanique.com".

Characteristics (continued)							
Encoder interface card with open collector outputs							
Type of card		VW3 A3 403		VW3 A3 404			
Power supply (supplied by the card)	Voltage	12 V $\pm$ (min. 12 V, max. 13 V)		15 V $\pm$ (min. 15 V, max. 16 V)			
	Maximum current	175 mA					
Short-circuit and overload protection							
Maximum cable length		500 m					
Maximum operating frequency		300 kHz					
Input signals		A, $\bar{A}$ , B, $\bar{B}$ / AB / A					
Impedance		1 k $\Omega$					
Number of pulses/encoder revolution		5000 maximum The maximum high-speed frequency should not exceed 300 kHz					
Encoder consumption		100 mA at 10 V	175 mA at 10 V	100 mA at 10 V	175 mA at 10 V		
Minimum cross-section recommended for the conductors (1)	For a maximum cable length of 100 m	0.2 mm <sup>2</sup> (AWG 24)	0.5 mm <sup>2</sup> (AWG 20)	0.2 mm <sup>2</sup> (AWG 24)			
	For a maximum cable length of 200 m	0.5 mm <sup>2</sup> (AWG 20)	0.75 mm <sup>2</sup> (AWG 18)	0.2 mm <sup>2</sup> (AWG 24)			
	For a maximum cable length of 500 m	1 mm <sup>2</sup> (AWG 17)	1.5 mm <sup>2</sup> (AWG 15)	0.5 mm <sup>2</sup> (AWG 20)			
Encoder interface card with push-pull outputs							
Type of card		VW3 A3 405		VW3 A3 406		VW3 A3 407	
Power supply (supplied by the card)	Voltage	12 V $\pm$ (min. 12 V, max. 13 V)		15 V $\pm$ (min. 15 V, max. 16 V)		24 V $\pm$ (min. 20 V, max. 30 V)	
	Maximum current	175 mA				100 mA	
Short-circuit and overload protection							
Maximum cable length		500 m					
Maximum operating frequency		300 kHz					
Input signals		A, $\bar{A}$ , B, $\bar{B}$ / AB / A					
Impedance		1 k $\Omega$				1.6 k $\Omega$	
State 0		If < 1.5 V					
State 1		If > 7.7 V and < 13 V		If > 7.7 V and < 16 V		If > 11.5 V and < 25 V	
Number of pulses/encoder revolution		5000 maximum The maximum high-speed frequency should not exceed 300 kHz					
Encoder consumption		100 mA at 10 V	175 mA at 10 V	100 mA at 10 V	175 mA at 10 V	100 mA at 14 V	
Minimum cross-section recommended for the conductors (1)	For a maximum cable length of 100 m	0.2 mm <sup>2</sup> (AWG 24)	0.5 mm <sup>2</sup> (AWG 20)	0.2 mm <sup>2</sup> (AWG 24)			
	For a maximum cable length of 200 m	0.5 mm <sup>2</sup> (AWG 20)	0.75 mm <sup>2</sup> (AWG 18)	0.2 mm <sup>2</sup> (AWG 24)			
	For a maximum cable length of 500 m	1 mm <sup>2</sup> (AWG 17)	1.5 mm <sup>2</sup> (AWG 15)	0.5 mm <sup>2</sup> (AWG 20)		0.2 mm <sup>2</sup> (AWG 24)	
Type of encoder		XCC 1●●●●●Y, K, KN (2)					

## References

Encoder interface cards (3)			
Description	Voltage V	Reference	Weight kg
Encoder interface cards with RS 422 compatible differential outputs	5	VW3 A3 401	0.200
Encoder interface cards with open collector outputs	12	VW3 A3 403	0.200
	15	VW3 A3 404	0.200
Encoder interface cards with push-pull outputs	12	VW3 A3 405	0.200
	15	VW3 A3 406	0.200
	24	VW3 A3 407	0.200

- (1) Shielded cable containing 3 twisted pairs at intervals of between 20 and 50 mm. Connect the shielding to earth at both ends. Minimum recommended conductor cross-section for a minimum encoder voltage in order to limit line voltage drops.
- (2) To obtain the complete encoder reference, please refer to the "Global Detection - Electronic and Electromechanical Sensors" catalogue or visit our website "www.telemecanique.com".
- (3) The Altivar 61 drive cannot support more than one encoder interface card. Consult the summary tables of possible drive, option and accessory combinations on pages 170 to 179.

### Presentation

532726

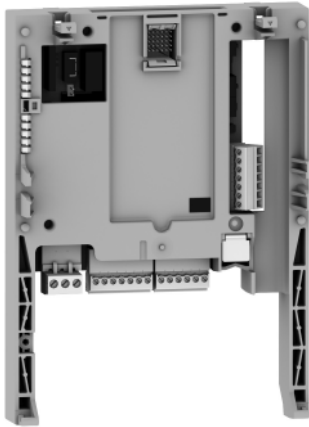

VW3 A3 202

Altivar 61 drives can be specifically adapted to particular application areas by installing I/O extension cards.

Two models are available:

■ Card with logic I/O featuring:

- 1 relay logic output ("C/O" contact)
- 4 x 24 V  $\overline{\text{---}}$  positive or negative logic inputs
- 2 x 24 V  $\overline{\text{---}}$  positive or negative logic open collector outputs
- 1 input for PTC probes

■ Card with extended I/O featuring:

- 1 differential current analog input 0...20 mA
- 1 software-configurable voltage (0...10 V  $\overline{\text{---}}$ ) or current (0...20 mA) analog input
- 2 software-configurable voltage ( $\pm 10$  V, 0...10 V  $\overline{\text{---}}$ ) or current (0...20 mA) analog outputs
- 1 relay logic output
- 4 x 24 V  $\overline{\text{---}}$  positive or negative logic inputs
- 2 x 24 V  $\overline{\text{---}}$  positive or negative logic open collector outputs
- 1 input for PTC probes
- 1 frequency control input

### Characteristics

#### Logic I/O card VW3 A3 201

<b>Available internal supplies</b>		Short-circuit and overload protection: <ul style="list-style-type: none"> <li>■ 1 x 24 V <math>\overline{\text{---}}</math> supply (min. 21 V, max. 27 V), maximum current 200 mA for the complete drive and I/O extension card assembly</li> <li>■ 1 x 10.5 V <math>\overline{\text{---}}</math> (<math>\pm 5\%</math>) supply for the reference potentiometer (1 to 10 k<math>\Omega</math>), maximum current 10 mA</li> </ul>
<b>Configurable relay output</b> R3A, R3B, R3C		1 relay logic output, one "N/C" contact and one "N/O" contact with common point Minimum switching capacity: 3 mA for 24 V $\overline{\text{---}}$ Maximum switching capacity: <ul style="list-style-type: none"> <li>■ On resistive load (<math>\cos \varphi = 1</math>): 5 A for 250 V <math>\sim</math> or 30 V <math>\overline{\text{---}}</math></li> <li>■ On inductive load (<math>\cos \varphi = 0.4</math> and L/R = 7 ms): 2 A for 250 V <math>\sim</math> or 30 V <math>\overline{\text{---}}</math></li> </ul> Electrical service life: 100,000 operations Maximum response time: 7 ms $\pm$ 0.5 ms
<b>Logic inputs</b>	LI7...LI10	4 programmable logic inputs 24 V $\overline{\text{---}}$ , compatible with level 1 PLC, standard IEC/EN 61131-2 Impedance 3.5 k $\Omega$ Maximum voltage: 30 V Multiple assignment makes it possible to configure several functions on one input Maximum sampling time: 2 ms $\pm$ 0.5 ms
	Positive logic (Source)	State 0 if $\leq 5$ V or logic input not wired, state 1 if $\geq 11$ V
	Negative logic (Sink)	State 0 if $\geq 16$ V or logic input not wired, state 1 if $\leq 10$ V
<b>Logic outputs</b> LO1, LO2		2 x 24 V $\overline{\text{---}}$ logic outputs assignable as positive logic (Source) or negative logic (Sink) open collector type, compatible with level 1 PLC, standard IEC/EN 61131-2 24 V $\overline{\text{---}}$ internal or 24 V $\overline{\text{---}}$ external power supply (min. 12 V, max. 30 V) Maximum current: 200 mA Logic output common (CLO) isolated from other signals Maximum sampling time: 2 ms $\pm$ 0.5 ms. The active state is software-configurable as is a delay for each switching operation
<b>Input for PTC probes</b> TH1+/TH1-		1 input for a maximum of 6 PTC probes mounted in series: <ul style="list-style-type: none"> <li>■ Nominal value &lt; 1.5 k<math>\Omega</math></li> <li>■ Trip resistance 3 k<math>\Omega</math>, reset value 1.8 k<math>\Omega</math></li> <li>■ Short-circuit protection &lt; 50 <math>\Omega</math></li> </ul> This PTC probe input must never be used to protect an ATEX motor in applications in explosive atmospheres (1)
<b>Maximum I/O wire size and tightening torque</b>		1.5 mm <sup>2</sup> (AWG 16) 0.25 Nm

(1) Please refer to the ATEX guide, available on our website "www.telemecanique.com".

### Characteristics (continued)

#### Extended I/O card VW3 A3 202

Available internal supplies		<p>Short-circuit and overload protection:</p> <ul style="list-style-type: none"> <li>1 x 24 V <math>\overline{\text{---}}</math> supply (min. 21 V, max. 27 V), maximum current 200 mA for the complete drive and I/O extension card assembly</li> <li>1 x 10.5 V <math>\overline{\text{---}}</math> (<math>\pm 5\%</math>) supply for the reference potentiometer (1 to 10 k<math>\Omega</math>), maximum current 10 mA</li> </ul>
Analog inputs AI	AI3+/AI3-	<p>1 X-Y mA differential current analog input by programming X and Y from 0 to 20 mA, with impedance 250 <math>\Omega</math></p> <p>Maximum sampling time: 5 ms <math>\pm</math> 1 ms</p> <p>Resolution: 11 bits + 1 sign bit</p> <p>Accuracy: <math>\pm 0.6\%</math> for a temperature variation of 60°C</p> <p>Linearity: <math>\pm 0.15\%</math> of the maximum value</p>
	AI4	<p>1 software-configurable voltage or current analog input:</p> <ul style="list-style-type: none"> <li>Voltage analog input, 0...10 V <math>\overline{\text{---}}</math>, impedance 30 k<math>\Omega</math> (max. safe voltage 24 V)</li> <li>X-Y mA current analog input by programming X and Y from 0 to 20 mA, with impedance 250 <math>\Omega</math></li> </ul> <p>Maximum sampling time: 5 ms <math>\pm</math> 1 ms</p> <p>Resolution: 11 bits</p> <p>Accuracy: <math>\pm 0.6\%</math> for a temperature variation of 60°C</p> <p>Linearity: <math>\pm 0.15\%</math> of the maximum value</p>
Analog outputs	AO2, AO3	<p>2 software-configurable voltage or current analog outputs:</p> <ul style="list-style-type: none"> <li>Voltage analog output, <math>\pm 10</math> V, 0...10 V <math>\overline{\text{---}}</math>, minimum load impedance 470 <math>\Omega</math></li> <li>X-Y mA current analog output by programming X and Y from 0 to 20 mA, maximum load impedance 500 <math>\Omega</math></li> </ul> <p>Maximum sampling time: 5 ms <math>\pm</math> 1 ms</p> <p>Resolution: 10 bits</p> <p>Accuracy: <math>\pm 1\%</math> for a temperature variation of 60°C</p> <p>Linearity: <math>\pm 0.2\%</math> of the maximum value</p>
Configurable relay output	R4A, R4B, R4C	<p>1 relay logic output, one "N/C" contact and one "N/O" contact with common point</p> <p>Minimum switching capacity: 3 mA for 24 V <math>\overline{\text{---}}</math></p> <p>Maximum switching capacity:</p> <ul style="list-style-type: none"> <li>On resistive load (<math>\cos \varphi = 1</math>): 5 A for 250 V <math>\sim</math> or 30 V <math>\overline{\text{---}}</math></li> <li>On inductive load (<math>\cos \varphi = 0.4</math> and L/R = 7 ms): 1.5 A for 250 V <math>\sim</math> or 30 V <math>\overline{\text{---}}</math></li> </ul> <p>Electrical service life: 100,000 operations</p> <p>Maximum response time: 10 ms <math>\pm</math> 1 ms</p>
Logic inputs	LI11...LI14	<p>4 programmable logic inputs, 24 V <math>\overline{\text{---}}</math>, compatible with level 1 PLC, standard IEC/EN 61131-2</p> <p>Impedance 3.5 k<math>\Omega</math></p> <p>Maximum voltage: 30 V</p> <p>Multiple assignment makes it possible to configure several functions on one input</p> <p>Maximum sampling time: 5 ms <math>\pm</math> 1 ms</p>
	Positive logic (Source)	State 0 if $\leq 5$ V or logic input not wired, state 1 if $\geq 11$ V
	Negative logic (Sink)	State 0 if $\geq 16$ V or logic input not wired, state 1 if $\leq 10$ V
Logic outputs	LO3, LO4	<p>2 x 24 V <math>\overline{\text{---}}</math> logic outputs assignable as positive logic (Source) or negative logic (Sink) open collector type, compatible with level 1 PLC, standard IEC/EN 61131-2</p> <p>Maximum voltage: 30 V</p> <p>Maximum current: 200 mA</p> <p>Logic output common (CLO) isolated from other signals</p> <p>Maximum sampling time: 5 ms <math>\pm</math> 1 ms. The active state is software-configurable as is a delay for each switching operation.</p>
Input for PTC probes	TH2+/TH2-	<p>1 input for a maximum of 6 PTC probes mounted in series:</p> <ul style="list-style-type: none"> <li>Nominal value &lt; 1.5 k<math>\Omega</math></li> <li>Trip resistance 3 k<math>\Omega</math>, reset value 1.8 k<math>\Omega</math></li> <li>Short-circuit protection &lt; 50 <math>\Omega</math></li> </ul> <p>This PTC probe input must never be used to protect an ATEX motor in applications in explosive atmospheres (1)</p>
Frequency control input RP		<p>Frequency range: 0...30 kHz</p> <p>Cyclic ratio: 50% <math>\pm</math> 10%</p> <p>Maximum sampling time: 5 ms <math>\pm</math> 1 ms</p> <p>Maximum input voltage 30 V, 15 mA</p> <p>Add a resistor if the input voltage is greater than 5 V (510 <math>\Omega</math> for 12 V, 910 <math>\Omega</math> for 15 V, 1.3 k<math>\Omega</math> for 24 V)</p> <p>State 0 if &lt; 1.2 V, state 1 if &gt; 3.5 V</p>
Maximum I/O wire size and tightening torque		<p>1.5 mm<sup>2</sup> (AWG 16)</p> <p>0.25 Nm</p>

### References

#### I/O extension cards (2)

Description	Reference	Weight kg
Logic I/O card	VW3 A3 201	0.300
Extended I/O card	VW3 A3 202	0.300

(1) Please refer to the ATEX guide, available on our website "www.telemecanique.com".

(2) The Altivar 61 drive cannot support more than one I/O card with the same reference. Consult the summary tables of possible drive, option and accessory combinations on pages 170 to 179.

# Variable speed drives

## Altivar 61

Option: multi-pump cards

### Presentation

Multi-pump cards can be used to adapt the drive to pump applications. Various predefined, configurable applications are sold by Schneider Electric and its partners.

In order to protect our know-how, it is not possible to transfer the program from the card to the PC.

A single multi-pump card can be fitted in the Altivar 61 drive. It can be combined with another option card (I/O extension or communication). Refer to the tables summarizing the possible combinations: drives, options and accessories, see pages 170 to 179.

Each multi-pump card consists of:

- 10 logic inputs, 2 of which can be used for 2 counters
- 2 analog inputs
- 6 logic outputs
- 2 analog outputs
- A master port for the CANopen machine bus

If the power consumption table does not exceed 200 mA, this card can be powered by the ATV 61H●●●● drives.

Otherwise, an external 24 V  $\bar{\bar{}}$  power supply must be used.

The ATV 61W●●●N4A24 variable speed drives incorporate a 24 V  $\bar{\bar{}}$  power supply, allowing additional consumption of 250 mA.

Multi-pump cards can also operate:

- The drive I/O
- The I/O extension card I/O
- The drive parameters (speed, current, torque, etc.)

The Altivar 61 drive:

- Incorporates all the application functions for managing your pumps: sleep, wake-up, zero flow detection, fluid absence detection, underload detection, overload detection, PID regulator with preselected preset PID references
- Is used to adjust your pumps' operating points: 2/5-point quadratic ratio, energy saving ratio
- Protects your pumps: motor thermal protection, PTC management, low speed detection and time delay.

### Description

- 1 9-way male SUB-D connector for connection to the CANopen machine bus.
- 2 Connector with removable screw terminals, 6 contacts at intervals of 3.81 for the 24 V  $\bar{\bar{}}$  power supply and 4 logic inputs.
- 3 3 connectors with removable screw terminals, 6 contacts at intervals of 3.81 for 6 logic inputs, 6 logic outputs, 2 analog inputs, 2 analog outputs and 2 commons.
- 4 5 LEDs, comprising:
  - 1 to indicate the presence of the 24 V  $\bar{\bar{}}$  power supply
  - 1 to indicate a program execution fault
  - 2 to indicate the CANopen machine bus communication status
  - 1 controlled by the application program

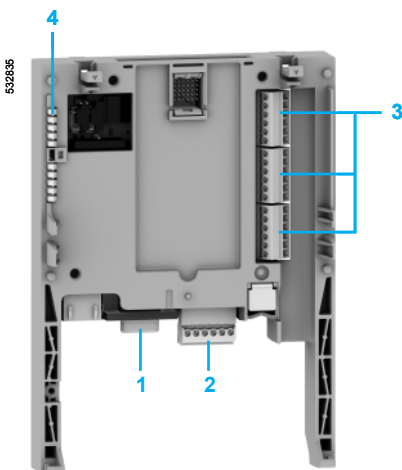

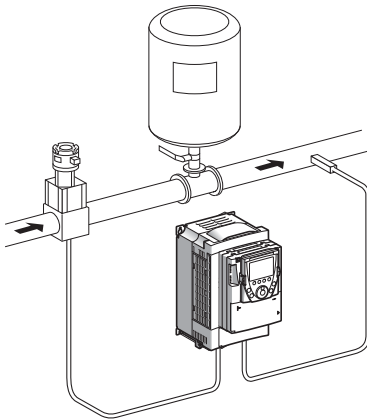

Single variable mode

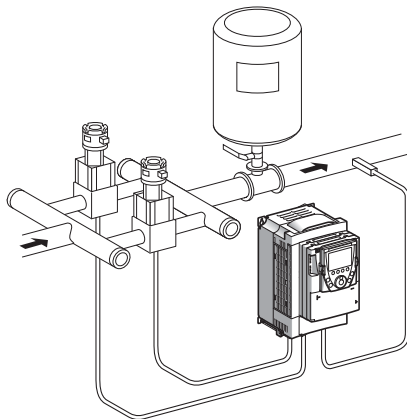

Single variable with auxiliary pump mode

### Operation

Multi-pump cards have the following basic operating modes:

#### Single variable

The variable speed pump is always the same.  
Fixed flow pumps are started in ascending order of the logic outputs.  
Fixed flow pumps are stopped in descending order of the logic outputs.

#### Multiple variable

All the pumps can be variable. The variable pump is selected according to its operating time. The pump with the shortest operating time is selected. Fixed pumps are started and stopped in ascending and descending order of the logic outputs respectively.

#### Switching the auxiliary pumps

A pump is started by selecting the one with the shortest operating time.  
A pump is stopped by selecting the one with the longest operating time.

#### Limiting the operating time between pumps

A relative operating time differential between each pump can be programmed to ensure better distribution of operating times, thereby limiting pump wear.  
If the total operating time differential between an operating auxiliary pump and one which is off exceeds the programmed differential, the first pump is stopped and replaced by the second one.

#### Continuity of service for your installation

If a pump is faulty (information on the Lix logic input) it is not taken into consideration and the start and stop conditions are determined by the other pumps. It is possible for each pump to:

- Display the operating time
- Reset the counter
- Save the operating times

# Variable speed drives

## Altivar 61

Option: multi-pump cards

### VW3 A3 502 multi-pump card

The **VW3 A3 502** multi-pump card ensures compatibility of pump applications developed for an Altivar 38 drive with an Altivar 61, without reprogramming.

The card's 9 operating modes are as follows:

- OFF: no function is activated; this mode is used in particular during the installation's maintenance
- Single variable
- Multiple variable
- Single variable with changeover of auxiliary pumps
- Multiple variable with changeover of auxiliary pumps
- Single variable with limited operating time
- Multiple variable with limited operating time
- Single variable with changeover of auxiliary pumps and limited operating time
- Multiple variable with changeover of auxiliary pumps and limited operating time

### VW3 A3 503 "Water solution" multi-pump card

The **VW3 A3 503** multi-pump card is used to support all multi-pump applications.

However, this card does not ensure the compatibility of pump applications developed for an Altivar 38 drive.

In addition to the above-mentioned operating modes, it is possible to develop new applications: booster station, irrigation, etc.

Electrical characteristics			
<b>Power supply</b>	Voltage	<b>V</b>	24 V $\overline{\text{---}}$ (min. 19, max. 30)
<b>Consumption</b>	Maximum	<b>A</b>	2
	Current	<b>mA</b>	80
<b>Analog inputs</b>	AI51, AI52	<b>mA</b>	200 maximum (1)
			2 current analog inputs 0...20 mA, impedance 250 $\Omega$ Resolution: 10 bits Accuracy: $\pm 1\%$ for a temperature variation of 60°C Linearity: $\pm 0.2\%$ of the maximum value Common point for all the card I/O (2)
<b>Analog outputs</b>	AO51, AO52		2 current analog outputs 0...20 mA, impedance 500 $\Omega$ Resolution: 10 bits Accuracy: $\pm 1\%$ for a temperature variation of 60°C Linearity: $\pm 0.2\%$ of the maximum value Common point for all the card I/O (2)
<b>Logic inputs</b>	LI51...LI60		Ten 24 V $\overline{\text{---}}$ logic inputs, compatible with level 1 PLC, IEC 65A-68 standard, 2 of which can be used for 2 counters or 4 of which can be used for 2 incremental encoders Impedance 4.4 k $\Omega$ Maximum voltage: 30 V $\overline{\text{---}}$ Switching thresholds: State 0 if $\leq 5$ V or logic input not wired State 1 if $\geq 11$ V Common point for all the card I/O (2)
<b>Logic outputs</b>	LO51...LO56		Six 24 V $\overline{\text{---}}$ logic outputs, positive logic open collector type (source), compatible with level 1 PLC, IEC/EN 61131-2 standard Maximum switching voltage: 30 V Maximum current: 200 mA Common point for all the card I/O (2)
<b>I/O connection</b>	Type of contact		Screw at intervals of 3.81 mm <sup>2</sup>
	Maximum wire size	<b>mm<sup>2</sup></b>	1.5 (AWG 16)
	Tightening torque	<b>Nm</b>	0.25
<b>Lithium battery</b>	Life		8 years approx.

References (3)			
Description	Use	Reference	Weight kg
<b>Multi-pump card (4)</b> equipped with one 9-way male SUB-D connector	This card ensures compatibility of applications developed for an ATV 38 drive with an ATV 61 drive	<b>VW3 A3 502</b>	0.320
<b>"Water solution" multi-pump card (4)</b> equipped with one 9-way male SUB-D connector	This card means an ATV 61 drive can support all multi-pump applications	<b>VW3 A3 503</b>	0.320

(1) If the power consumption table does not exceed 200 mA, this card can be powered by the drive. Otherwise, an external 24 V  $\overline{\text{---}}$  power supply must be used.

(2) This common point is also the drive 0 V.

(3) It is recommended that a Nautilus<sup>®</sup> electronic pressure sensor, type XML F or XML G is added to the installation. Please refer to the "Global Detection - Electronic and electromechanical sensors" catalogue or our website at [www.telemecanique.com](http://www.telemecanique.com).

(4) The Altivar 61 drive cannot support more than one multi-pump card. Refer to the tables summarizing the possible combinations: drives, options and accessories, see pages 170 to 179.



# Variable speed drives

## Altivar 61

Option: "Controller Inside" programmable card

### Presentation

The "Controller Inside" programmable card is used to adapt the variable speed drive to specific applications by integrating control system functions.

Various predefined, configurable applications are sold by Schneider Electric and its partners.

The PS 1131 software workshop for PC is used for programming and debugging new applications, quickly and in an open-ended manner (see page 121).

It is not possible to transfer the program from the card to the PC, as we need to protect our know-how.

A single "Controller Inside" programmable card can be fitted in the Altivar 61 drive. It can be combined with another option card (I/O extension or communication).

Consult the summary tables of possible drive, option and accessory combinations, see pages 170 to 179.

The "Controller Inside" programmable card has:

- 10 logic inputs, 2 of which can be used for 2 counters or 4 of which can be used for 2 incremental encoders
- 2 analog inputs
- 6 logic outputs
- 2 analog outputs
- A master port for the CANopen machine bus
- A PC port for programming with the PS 1131 software workshop

If the power consumption table does not exceed 200 mA, the "Controller Inside" programmable card can be powered by Altivar 61 drives. Otherwise, an external 24 V  $\text{DC}$  power supply must be used.

The ATV 61W●●●N4A24 variable speed drives incorporate a 24 V  $\text{DC}$  power supply, allowing additional consumption of 250 mA.

The "Controller Inside" programmable card can also use:

- The drive I/O
- The I/O extension card I/O
- The encoder interface card points counter
- The drive parameters (speed, current, torque, etc.)

### Description

- 1 RJ45 connector for connecting the PS 1131 software workshop via an RS 485 serial link.  
Connection to the PC is via a cordset and an RS 232/RS 485 converter included in the PowerSuite for PC connection kit VW3 A8 106.
- 2 9-way male SUB-D connector for connection to the CANopen machine bus.
- 3 Connector with removable screw terminals, 6 contacts at intervals of 3.81 for the 24 V  $\text{DC}$  power supply and 4 logic inputs.
- 4 3 connectors with removable screw terminals, 6 contacts at intervals of 3.81 for 6 logic inputs, 6 logic outputs, 2 analog inputs, 2 analog outputs and 2 commons.
- 5 5 LEDs, comprising:
  - 1 to indicate the presence of the 24 V  $\text{DC}$  power supply
  - 1 to indicate a program execution fault
  - 2 to indicate the CANopen machine bus communication status
  - 1 controlled by the application program

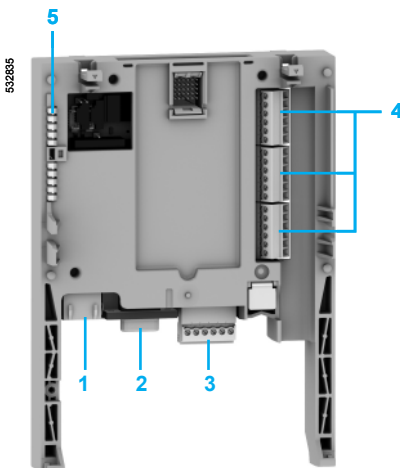

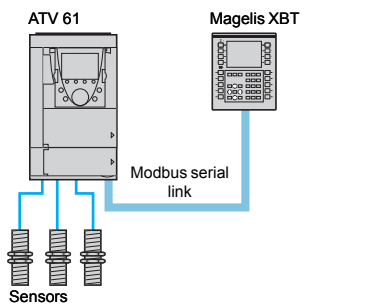

Independent machine with multiwire system

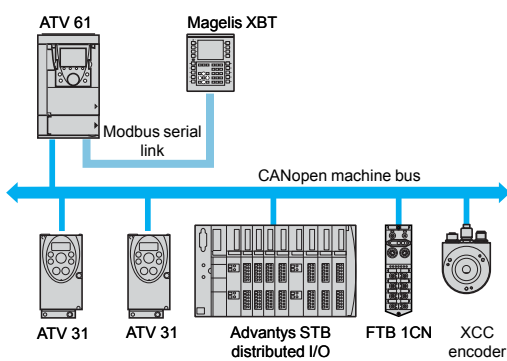

Independent machine with CANopen machine bus

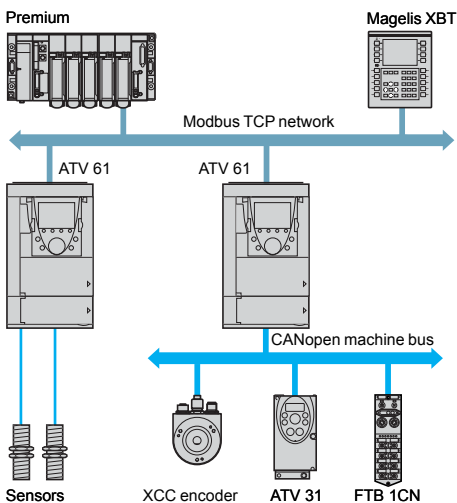

Modular machine with Modbus TCP network

### Dialogue

Human-machine dialogue with the application programmed in the "Controller Inside" programmable card is possible using:

- The Altivar 61 graphic display terminal
- A Magelis industrial HMI terminal connected to the drive Modbus port
- A Magelis industrial HMI terminal connected to the Modbus TCP network (if the drive is equipped with a Modbus TCP communication card)

There is a dedicated graphic terminal menu for the "Controller Inside" programmable card. This menu can be customized by the card program according to the application.

Any industrial HMI terminal which supports the Modbus protocol can be used to display and modify the "Controller Inside" programmable card parameters. The Modbus server provides access to 2 Kwords (% MW, etc.) in the card.

### Master CANopen communication

The master CANopen port on the "Controller Inside" programmable card can be used to extend the I/O capacity and to control other CANopen slave devices.

### Communication with a PLC

The Altivar 61 drive, which is equipped with a "Controller Inside" programmable card, integrates easily into complex architectures. Regardless of which bus, network or serial link is being used (Modbus TCP, Modbus/Uni-Telway, Fipio, Modbus Plus, PROFIBUS DP, INTERBUS, etc.), the PLC can communicate with the "Controller Inside" programmable card and the drive. The periodic variables can still be configured as required.

### Clock

A clock backed up by a lithium battery makes it possible to keep a log of events that have occurred. When the "Controller Inside" programmable card is installed in the drive, drive faults are automatically time and date-stamped without the need for any special programming.

Electrical characteristics			
<b>Power supply</b>	Voltage	<b>V</b>	24 --- (min. 19, max. 30)
<b>Consumption</b>	Maximum	<b>A</b>	2
	No-load	<b>mA</b>	80
	Per logic output	<b>mA</b>	200 maximum (1)
<b>Analog inputs</b>	AI51, AI52		2 current analog inputs 0...20 mA, impedance 250 Ω Resolution: 10 bits Accuracy: ± 1% for a temperature variation of 60°C Linearity: ± 0.2% of the maximum value Common point for all the card I/O (2)
<b>Analog outputs</b>	AO51, AO52		2 current analog outputs 0...20 mA, impedance 500 Ω Resolution: 10 bits Accuracy: ± 1% for a temperature variation of 60°C Linearity: ± 0.2% of the maximum value Common point for all the card I/O (2)
<b>Logic inputs</b>	LI51...LI60		Ten 24 V --- logic inputs, compatible with level 1 PLC, IEC/EN 61131-2 standard, 4 of which can be used for: ■ 1 counter and/or 1 incremental encoder ■ 2 counters Impedance 4.4 kΩ Maximum voltage: 30 V --- Switching thresholds: State 0 if ≤ 5 V or logic input not wired State 1 if ≥ 11 V Common point for all the card I/O (2)
<b>Logic outputs</b>	LO51...LO56		Six 24 V --- logic outputs, positive logic open collector type (source), compatible with level 1 PLC, IEC/EN 61131-2 Maximum switching voltage: 30 V Maximum current: 200 mA Common point for all the card I/O (2)
<b>I/O connection</b>	Type of contact		Screw at intervals of 3.81 mm <sup>2</sup>
	Maximum wire size	<b>mm<sup>2</sup></b>	1.5 (AWG 16)
	Tightening torque	<b>Nm</b>	0.25
<b>Lithium battery</b>	Life		8 years approx.

Characteristics of the application program			
<b>Compiled program</b> (saved in "flash" memory)	Maximum size	<b>Kb</b>	320
<b>Data</b>	Maximum size	<b>Kwords</b>	64
	Saved size (NVRAM)	<b>Kwords</b>	4
	Size accessible by Modbus	<b>Kwords</b>	2

Characteristics of the CANopen communication port		
<b>Structure</b>	Connector	One 9-way male SUB-D connector
	Network management	Master
	Transmission speed	Configurable via the program: 50 Kbps, 125 Kbps, 250 Kbps, 500 Kbps or 1 Mbps
	Address (Node ID)	32 slaves maximum
<b>Services</b>	CANopen application layer	DS 301 V4.02
	Profile	DSP 405
	PDO	10 receive and transmit PDOs in total for each slave
	SDO	2 client SDOs per slave (1 read and 1 write). Block transfer.
	Error check	Node Guarding, producer and consumer Heartbeat
	Other services	Emergency, Boot-up, Sync
<b>Diagnostics</b>	Using LEDs	2 LEDs: "RUN" and "ERROR", conforming to CIA DR303 version 1.0

(1) Otherwise, an external 24 V --- power supply must be used.  
(2) This common point is also the drive 0 V.

### PS 1131 software workshop

The PS 1131 software workshop conforms to international standard IEC 61131-3 and includes all the functions for programming and setting up the "Controller Inside" programmable card.

It includes the configurator for CANopen.

It is designed for Microsoft Windows® 98, Microsoft Windows® NT 4.0, Microsoft Windows® Millennium, Microsoft Windows® 2000 Professional and Microsoft Windows® XP operating systems.

It benefits from the user-friendly interface associated with these operating systems:

- Pop-up menus
- Function blocks
- Online help

The PS 1131 software workshop is available in both English and German.

The programming and debugging tools can be accessed via the application browser. This provides the user with an overview of the program and quick access to all application components:

- Program editor
- Function blocks editor
- Variables editor
- Animation tables editor
- Runtime screens editor

### Modular structured programming

The PS 1131 software workshop is used to structure an application into function modules consisting of sections (program code), animation tables and runtime screens. Each program section has a name and is programmed in one of the six available languages. To protect know-how or prevent any accidental modification, each section can be write-protected or read/write-protected.

### Exporting/Importing function modules

It is possible to export all or part of the tree structure in function modules.

### Program structure and execution of an application

The program structure is single-task. It consists of several subroutines.

Exchanges with the drive are performed by a function block available in the standard library.

Cycle execution can be either cyclic or periodic. A software watchdog, which can be configured between 100 and 800 ms by the user, monitors the cycle time.

A task can be synchronized with the drive main task to improve repeat accuracy in motion control applications.

### Cyclic execution

Once each cycle ends, execution of a new cycle begins. Cycle execution must last for at least 5 ms.

### Periodic execution

The program is executed periodically, and the period can be set by the user between 5 and 100 ms. Cycle execution must last for less than the defined period. The drive response in the event of the cycle time being exceeded can be managed by the program.

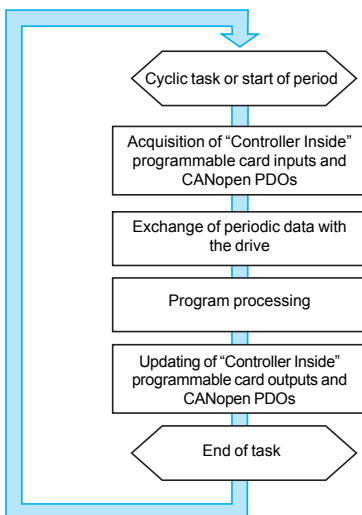

Example of cycle execution for the "Controller Inside" programmable card connected on a CANopen machine bus

# Variable speed drives

Altivar 61

Option: "Controller Inside" programmable card

## Programming languages

6 programming languages are available:

- Ladder Diagram (LD)
- Structured Text language (ST)
- Grafcet language (SFC)
- Instruction List language (IL)
- Function Block Diagram (FBD)
- Continuous Flow Chart (CFC)

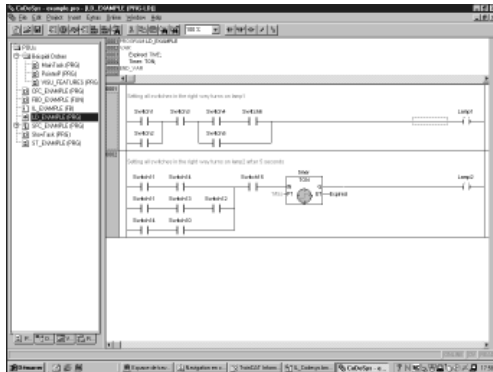

Example of Ladder Diagram language programming

### Ladder Diagram (LD)

A Ladder Diagram program consists of a set of rungs executed sequentially.

A rung consists of several lines.

A line consists of several contacts and a coil.

The language objects can be entered and displayed as symbols or tags as required.

The Ladder Diagram editor enables the immediate call of entry help functions such as access to function libraries and access to the variables editor

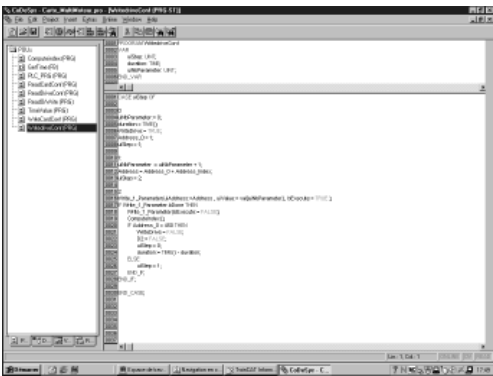

Example of Structured Text language programming

### Structured Text (ST)

Structured Text language is a sophisticated algorithmic-type language which is particularly well suited to programming complex arithmetical functions, manipulating tables, message handling, etc.

Structured Text language enables direct transcription of an analysis based on a flow chart, and is organized in statements.

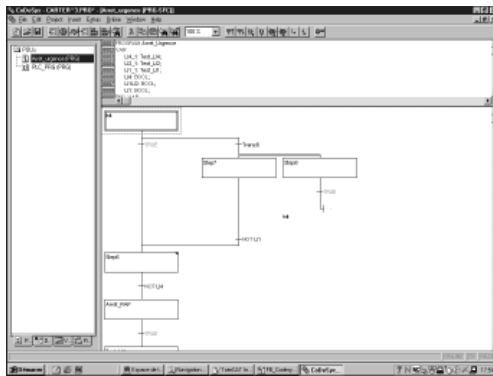

Example of Grafcet language programming

### Grafcet language (SFC)

Grafcet language is used to describe the sequential part of the control system in a simple, graphic way. It corresponds to the "Sequential Function Chart" (SFC) language described in standard IEC/EN 61131-3.

Programs written in Grafcet (SFC) language consist of:

- Macro-steps which are groups of steps and transitions
- Steps relating to the actions to be performed
- Transitions relating to the conditions (transition conditions)
- Directed links connecting the steps and transitions

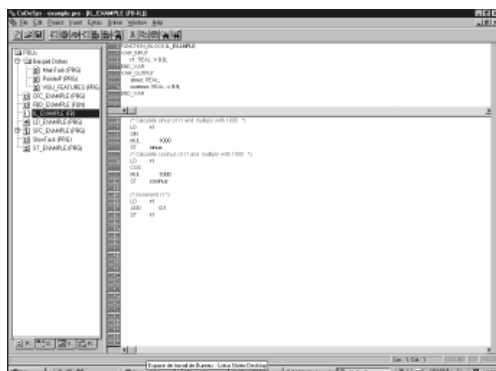

Example of Instruction List language programming



Example of a function block: sending the speed reference to the drive.

### Programming languages (continued)

#### Instruction List Language (IL)

Instruction List language can be used to write Boolean equations and use all the functions available in the language. It can be used to represent the equivalent of a ladder diagram in text form.

Each instruction consists of an instruction code and a bit or word type operand.

As in Ladder Diagram language, instructions are organized in sequences of instructions called statements (equivalent to a rung).

#### Function Block Diagram (FBD)

FBD is a graphic language. It consists of function blocks connected by a rung. The program is executed sequentially.

Each block can be a logical or arithmetical expression, a call to another function block, a jump or a return instruction.

#### Continuous Flow Chart (CFC)

Continuous Flow Chart programming is a graphic language. The rung connecting the various function blocks on the page is not necessarily sequential. The output of a function block may be looped back on its input or on the input of a block already inserted in the rung.

### Function blocks

The PS 1131 software workshop features pre-programmed function blocks (standard library) and offers users the option of creating their own function blocks (user library).

#### Standard library

The standard library contains:

- Logic functions (AND, OR, etc.)
- Mathematical functions (Cos, Sin, Exp, etc.)
- Function blocks dedicated to drives which facilitate data exchange between the drive and the "Controller Inside" programmable card (example: sending the speed reference)
- Function blocks for managing the CANopen machine bus
- Graphic terminal display function blocks

#### User library

Users have the option of creating their own function blocks to help them structure their applications. This also provides a means of protecting the know-how contained in the algorithms by locking access to the user function blocks program.

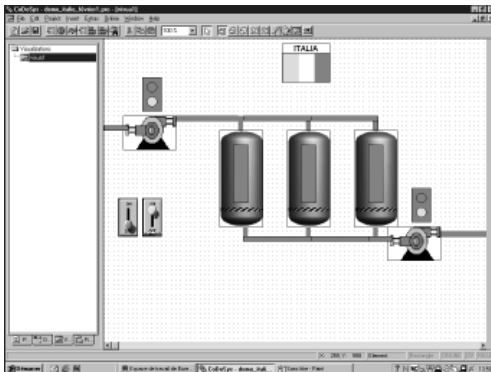

Example of runtime screen

### Debugging

The PS 1131 software workshop offers a complete set of tools for debugging the application.

#### Program execution for debugging

The main debugging functions are:

- Use of breakpoints
- Step-by-step program execution
- Execution of a single cycle
- Direct access to the subroutines that have been called (call stack)

#### Realtime program animation

The main realtime program animation functions are as follows:

- Animation of part of the program in any language
- Automatic display of a variables window relating to this part of the program

#### Animation tables

Tables containing variables for the application to be monitored can be created and saved.

In both these tools, in addition to animating the data, it is possible to:

- Modify and force the value of any type of data
- Change the display format (binary, hexadecimal, etc.)

#### Oscilloscope

The PS 1131 software workshop Oscilloscope function can be used to monitor up to 20 variables in the form of curves.

#### Runtime screens

A tool integrated in the PS 1131 software workshop can be used to design and use runtime screens for the application:

- Creation of screen backgrounds
- Animation of graphic objects associated with variables
- Display of messages
- Etc.

#### Simulation

The PS 1131 software workshop Simulation function can be used to test the program without having to set up the drive.

## Variable speed drives

## Altivar 61

Option: "Controller Inside" programmable card

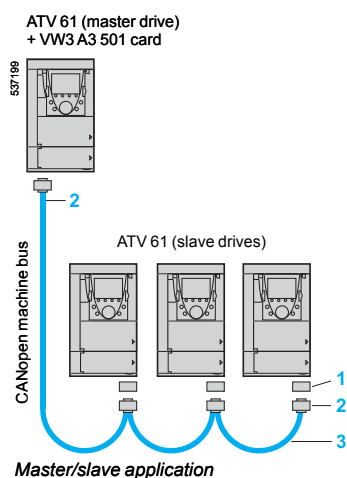

## References

## Card

Description	Reference	Weight kg
"Controller Inside" programmable card (1) equipped with one 9-way male SUB-D connector	VW3 A3 501	0.320

## Connection accessories (2)

Description	No.	Reference	Weight kg
CANopen adapter for mounting on the RJ45 socket in the drive control terminals. The adapter provides a 9-way male SUB-D connector conforming to the CANopen standard (CIA DRP 303-1).	1	VW3 CAN A71	-
CANopen connector 9-way female SUB-D with line terminator that can be disabled	2	TSX CAN KCDF 180T	-

## Cables (2)

Description	No.	Length m	Reference	Weight kg
CANopen cables Standard cable, C€ marking Low smoke emission, halogen-free. Flame retardant (IEC 60332-1)	3	50	TSX CAN CA 50	4.930
		100	TSX CAN CA 100	8.800
		300	TSX CAN CA 300	24.560
CANopen cables UL certification, C€ marking Flame retardant (IEC 60332-2)	3	50	TSX CAN CB 50	3.580
		100	TSX CAN CB 100	7.840
		300	TSX CAN CB 300	21.870
CANopen cables Cable for harsh environments (3) or mobile installation, C€ marking Low smoke emission, halogen-free. Flame retardant (IEC 60332-1)	3	50	TSX CAN CD 50	3.510
		100	TSX CAN CD 100	7.770
		300	TSX CAN CD 300	21.700

## PS 1131 software workshop

Description	Reference	Weight kg
PS 1131 software workshop supplied on CD-ROM	(4)	-
Connection kit for PC serial port including various accessories such as: ■ 1 x 3 m cable with 2 RJ45 connectors ■ 1 RS 232/RS 485 converter with one 9-way female SUB-D connector and 1 RJ45 connector	VW3 A8 106	0.350

(1) The Altivar 61 drive can only take one "Controller Inside" programmable card. Refer to the tables summarizing the possible combinations: drives, options and accessories, see pages 170 to 179.

(2) Please refer to the "Machines and installations with CANopen" catalogue.

(3) Harsh environments:

- resistance to hydrocarbons, industrial oils, detergents, solder splashes
- relative humidity up to 100%
- saline atmosphere
- significant temperature variations
- operating temperature between - 10°C and + 70°C

(4) The product reference is provided as part of the "Controller Inside" programmable card training course. Please consult your Regional Sales Office.



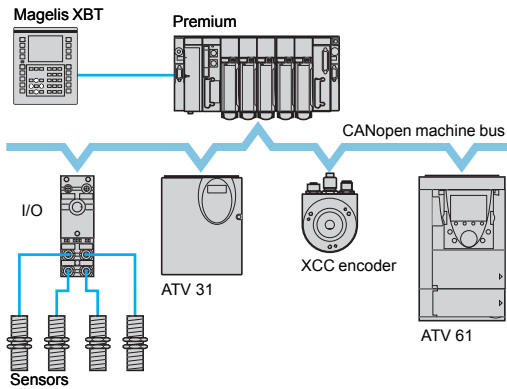

Example of configuration on CANopen machine bus

### Presentation

The Altivar 61 drive has been designed to meet all the configuration requirements encountered within the context of industrial communication installations.

It includes Modbus and CANopen communication protocols as standard.

The Modbus protocol can be accessed directly by means of 2 integrated communication ports (for characteristics, see page 17):

- One RJ45 Modbus terminal port **1** located on the drive front panel. This is for connecting:

- The remote graphic display terminal
- A Magelis industrial HMI terminal
- The PowerSuite software workshop

- One RJ45 Modbus network port **2** located on the drive's control terminals. It is assigned to control and signalling by a PLC or by another type of controller.

It can also be used to connect a terminal or the PowerSuite software workshop.

The CANopen protocol can be accessed from the Modbus network port via the CANopen adapter **3** (for characteristics, see page 17). In this case, terminal port **1** must be used to access the Modbus protocol.

By adding one of the 11 communication cards available as options, the Altivar 61 drive can also be connected to other networks and communication buses used in various application areas, such as industry and building management (HVAC) (1).

#### Communication cards for industrial applications:

- Modbus TCP
- Fipio
- Modbus/Uni-Telway: This card provides access to additional functions, which complement those of the integrated ports (Modbus ASCII and 4-wire RS 485)
- Modbus Plus
- Ethernet/IP
- DeviceNet
- PROFIBUS DP
- INTERBUS
- CC-link

#### Communication cards for building applications (HVAC):

- LONWORKS
- METASYS N2
- APOGEE FLN
- BACnet

The option of powering the control section separately enables communication (monitoring, diagnostics) to be maintained even if there is no power supply to the control section.

The main communication functions of Altivar 38 drives are compatible with the Altivar 61 (2):

- Connection
- Communication services
- Drive behaviour (profile)
- Control and monitoring parameters
- Standard adjustment parameters

(1) Heating, Ventilation and Air Conditioning

(2) Please refer to the ATV 38/ATV 61 Substitution Guide supplied on the documentation CD-ROM.

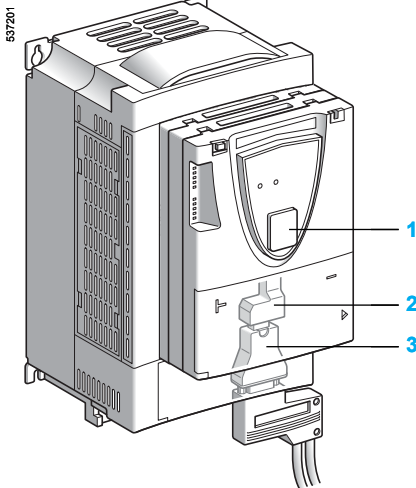

#### Functions

All the drive functions can be accessed via the network:

- Control
- Monitoring
- Adjustment
- Configuration

If the drive is equipped with a "Controller Inside" programmable card or a multi-pump card, its variables (% MW, etc.) can be accessed using the Modbus message handling services via the integrated communication ports or via the Modbus TCP communication card.

The speed control and reference may come from different sources:

- I/O terminals
- Communication network
- "Controller Inside" programmable card
- Multi-pump cards
- Remote graphic display terminal

The advanced functions of the Altivar 61 drive can be used to manage switching of these drive control sources according to the application requirements.

It is possible to choose the assignment of the communication periodic I/O data by means of:

- The network configuration software (Sycon, etc.)
- The Altivar 61's communication scanner function

For the integrated Modbus and CANopen ports and for communication cards for industrial applications, the Altivar 61 drive can be controlled:

- According to the CiA 402 profile
- According to the I/O profile where control is as simple and adaptable as control via the I/O terminals

The DeviceNet card also supports the CIP AC Drive and Allen-Bradley drive profiles.

Communication is monitored according to criteria specific to each protocol. However, regardless of the protocol, it is possible to configure how the drive responds to a communication fault:

- Freewheel stop, stop on ramp, fast stop or braked stop
- Maintain last command received
- Fallback position at a predefined speed
- Ignore the fault

A command from the CANopen machine bus is processed with the same priority as one of the drive terminal inputs. This results in excellent response times on the network port via the CANopen adapter.

#### Characteristics of the Modbus TCP card VW3 A3 310 (1)

<b>Structure</b>	Connector	One RJ45 connector
	Transmission speed	10/100 Mbps, half duplex and full duplex
	IP addressing	<ul style="list-style-type: none"> <li>■ Manual assignment via the display terminal or the PowerSuite software workshop</li> <li>■ BOOTP (dynamic IP address server depending on the IEEE address)</li> <li>■ DHCP (dynamic address server depending on the Device Name) with automatic reiteration</li> </ul>
	Physical	Ethernet 2
	Link	LLC: IEEE 802.2 MAC: IEEE 802.3
	Network	IP (RFC791) ICMP client for supporting certain IP services such as the "ping" command
	Transport	TCP (RFC793), UDP The maximum number of connections is 8 (port 502)
	<b>Services</b>	Transparent Ready class (2)
Web server		<p>Simultaneous access via three Web browsers (more, depending on the number of connections used) Server is factory-configured and modifiable The memory available for the application is approximately 1 MB</p> <p>The factory-configured server contains the following pages:</p> <ul style="list-style-type: none"> <li>■ Altivar viewer: displays the drive status and the state of its I/O, the main measurements (speed, current, etc.)</li> <li>■ Data editor: access to the drive parameters for configuration, adjustment and signalling</li> <li>■ Altivar chart: simplified oscilloscope function</li> <li>■ Security: configuration of passwords for viewing and modification access</li> <li>■ FDR Agent: configuration of the "Faulty Device Replacement" parameters</li> <li>■ IO Scanner: configuration of periodic parameters for controlling and monitoring the drive via the PLC, etc.</li> <li>■ Ethernet statistics: drive identification (IP addresses, version, etc.), Ethernet transmission statistics</li> <li>■ E-mail: configuration of the e-mail function</li> </ul>
E-mail		E-mail sent on alarm or fault
Messaging		<p>Read Holding Registers (03), 63 words maximum Read Input Registers (04), 63 words maximum Write Single Register (06) Write Multiple Registers (16), 63 words maximum Read/Write Multiple Registers (23) Read Device Identification (43) Diagnostics (08)</p>
I/O data		<p>I/O scanning service (can be inhibited):</p> <ul style="list-style-type: none"> <li>■ 10 control parameters which can be assigned by the PowerSuite software workshop or the standard Web server</li> <li>■ 10 monitoring parameters which can be assigned by the PowerSuite software workshop or the standard Web server</li> </ul> <p>The Global Data service is not supported</p>
FDR (Faulty Device Replacement)		Yes
Communication monitoring		<p>Can be inhibited Time out can be set between 0.5...60 s via the terminal, the PowerSuite software workshop or the standard Web server</p>
Device profiles		CiA 402 profile: "Device Profile Drives and Motion Control" I/O profile
Network management		SNMP
File transfer		FTP for Web server and TFTP for FDR
<b>Diagnostics</b>		Using LEDs
	Using the graphic display terminal	Control word received Reference received
	Via the Web server	Via the "Altivar viewer" and "Ethernet statistics" pages

(1) For Modbus TCP network, see pages 288 to 293.

(2) Please refer to the "Ethernet TCP/IP Transparent Ready" catalogue.

#### Characteristics of the EtherNet/IP card VW3 A3 316

<b>Structure</b>	Connector	2 RJ45 connectors	
	Transmission speed	10/100 Mbps, half duplex and full duplex, by manual selection or auto-negotiation	
	Address	Manual assignment via the graphic display terminal or the PowerSuite software workshop BOOTP DHCP	
	Physical	IEEE 802.3	
	Conformity level	Industrial	
	Link	LLC: IEEE 802.2 MAC: IEEE 802.3 Automatic switching	
	Network	IP (RFC791) ICMP client for supporting certain IP services such as the "ping" command	
	Transport	TCP (RFC793), UDP The maximum number of connections is 8 (port 502)	
	<b>Services</b>	CIP I/O data	Master/slave hierarchy <ul style="list-style-type: none"> <li>■ Speed CIP assemblies, type 20, 21, 70 and 71 (2 parameters)</li> <li>■ Speed/torque CIP assemblies, type 22, 23, 72 and 73 (3 parameters)</li> <li>■ Allen-Bradley assemblies, type 103 and 104 (10 parameters, 8 of which are assignable)</li> <li>■ Communication scanner assemblies, type 100 and 101 (8 parameters)</li> </ul>
CIP explicit messaging		Permits access to all the drive's parameters	
Web server		HTTP server: simultaneous access via 8 web browsers possible (depending on the number of connections used) Server is factory-configured and modifiable The memory available for the application is approximately 1 MB  The factory-configured server contains the following pages: <ul style="list-style-type: none"> <li>■ Drive monitor: displays the drive status and the state of its I/O, the main measurements (speed, current, etc.)</li> <li>■ Drive parameters: access to the drive parameters for configuration, adjustment and signalling</li> <li>■ Drive recorder: simplified oscilloscope function</li> <li>■ Security: configuration of passwords for reading and modification access</li> <li>■ Ethernet/IP setup: configuration of Ethernet, TCP/IP and CIP parameters</li> <li>■ Ethernet/IP scanner setup: configuration of I/O data (IO messaging)</li> <li>■ EtherNet statistics: drive identification (IP addresses, version, etc.), display of Ethernet transmission counters</li> <li>■ Message statistics: display of TCP/IP, CIP and Modbus messaging counters</li> <li>■ E-mail: configuration of the e-mail function</li> </ul>	
E-mail		E-mail sent on alarm, fault or fault reset	
Device profiles		CIP AC Drive (02) profile Allen-Bradley drive profile CiA 402 profile: "Device Profile Drives and Motion Control" I/O profile	
Network management		No	
File transfer		No	
<b>Diagnostics</b>		Using LEDs	5 LEDs on the card: "MS" (Module Status), "NS" (Network Status), "Link" (Link Status), "TX/RX" (Transmit/Receive port 1 and Transmit/Receive port 2)
		Using the graphic display terminal	Control word received Reference received Number of frames received
		Via the Web server	Via the "Drive monitor", "Drive parameters", "Ethernet statistics", "Message statistics" and "Net IO monitoring" pages

#### Characteristics of the Fipio card VW3 A3 311 (1)

<b>Structure</b>	Connector	One 9-way male SUB-D connector
	Transmission speed	1 Mbps
	Address	1 to 62, configurable using switches on the card
<b>Services</b>	Adjustment using PLC software (Unity, PL7)	No
	Periodic variables	8 control parameters which can be assigned by communication scanner 8 monitoring parameters which can be assigned by communication scanner Indexed periodic variable (adjustments)
	Communication profile	FED C 32
	Device profiles	CiA 402 profile: "Device Profile Drives and Motion Control" I/O profile
	Communication monitoring	Can be inhibited Fixed time out: 256 ms
<b>Diagnostics</b>	Using LEDs	4 LEDs on the card: "RUN" (status), "ERR" (fault), "COM" (data exchange) and "I/O" (minor internal fault)
	Using the graphic display terminal	Control word received Reference received Periodic variables (communication scanner)

#### Characteristics of the Modbus Plus card VW3 A3 302 (2)

<b>Structure</b>	Connector	One 9-way female SUB-D connector
	Transmission speed	1 Mbps
	Address	1 to 64, configurable using switches on the card
<b>Services</b>	Messaging	Yes (Modbus)
	I/O data	"Peer Cop": 8 control parameters which can be assigned by communication scanner "Global data": 8 monitoring parameters which can be assigned by communication scanner
	Device profiles	CiA 402 profile: "Device Profile Drives and Motion Control" I/O profile
	Communication monitoring	Can be inhibited Time out can be set between 0.1...60 s via the terminal or the PowerSuite software workshop.
<b>Diagnostics</b>	Using LEDs	1 LED on the card: "MB+" (status)
	Using the graphic display terminal	Control word received Reference received I/O data (communication scanner)

(1) For the Fipio bus, see pages 294 to 297.

(2) For the Modbus Plus network, see pages 302 to 305.

#### Characteristics of the DeviceNet card VW3 A3 309

<b>Structure</b>	Connector	One removable screw connector, 5 contacts at intervals of 5.08
	Transmission speed	125 kbps, 250 kbps or 500 kbps, configurable using switches on the card
	Address	1 to 63, configurable using switches on the card
<b>Services</b>	I/O data	<ul style="list-style-type: none"> <li>■ Speed CIP assemblies, type 20, 21, 70 and 71 (2 parameters)</li> <li>■ Speed/torque CIP assemblies, type 22, 23, 72 and 73 (3 parameters)</li> <li>■ Allen-Bradley assemblies, type 103, 104 (2 parameters) and 105 (4 parameters, 2 of which are assignable)</li> <li>■ Communication scanner assemblies, type 100 and 101 (4 assignable parameters)</li> </ul>
	Periodic exchange mode	Inputs: Polled, Change of state, Cyclic Outputs: Polled
	Device profiles	CIP AC Drive (02) profile Allen-Bradley drive profile CiA 402 profile: "Device Profile Drives and Motion Control" I/O profile
	Auto Device Replacement	No
	Communication monitoring	Can be inhibited Time out can be set via the DeviceNet network configurator
<b>Diagnostics</b>	Using LEDs	One two-tone LED on the card: "MNS" (status)
	Using the graphic display terminal	Control word received Reference received
<b>Description file</b>	A single eds file is supplied for the whole range on the documentation CD-ROM or can be downloaded from the website "www.telemecanique.com". This file contains the description of the drive parameters.	

#### Characteristics of the INTERBUS card VW3 A3 304

<b>Structure</b>	Connector	2 connectors: One 9-way male SUB-D and one 9-way female SUB-D
	Power supply	The card is powered by the drive. To ensure that the INTERBUS subscriber continues to operate during line supply failures to the power section, fit a separate power supply for the drive control section.
<b>Services</b>	Messaging	PCP: <ul style="list-style-type: none"> <li>■ Read: read a parameter</li> <li>■ Write: write a parameter</li> <li>■ Initiate: initialize the communication relationship</li> <li>■ Abort: abort the communication relationship</li> <li>■ Status: communication and drive status</li> <li>■ Get-OV: read an object description</li> <li>■ Identify: identification of the card</li> </ul>
	I/O data	2 control parameters (command and reference) 2 monitoring parameters (status and speed output)
	Device profile	Profile 21
	Communication monitoring	Can be inhibited Fixed time out: 640 ms
<b>Diagnostics</b>	Using LEDs	5 LEDs on the card: "U" (power supply), "RC" (bus input), "Rd" (bus output), "BA" (periodic data) and "TR" (messaging)
	Using the graphic display terminal	Control word received Reference received

#### Characteristics of the CC-Link card VW3 A3 317

<b>Structure</b>	Connector	One removable screw connector, 5 contacts at intervals of 3.81
	Physical interface	2-wire RS 485
	Line matching	Switch-configurable line terminator (110 Ω or 130 Ω)
	Transmission speed	156 kbps, 625 kbps, 2.5 Mbps, 5 Mbps, 10 Mbps Configurable using rotary switch on the card
	Address	1 to 64, configurable using 2 rotary switches on the card
<b>Services</b>	I/O data	Remote device station 32 remote digital inputs (RX) 32 remote digital outputs (RY) 4 remote input words (RWr) 4 remote output words (RWw)
	Device profile	Compatible with the CC-Link drive profile
	Adjustments	Access to the drive parameters via an indexing mechanism
	Communication monitoring	Can be inhibited Time out can be set between 0.1 s and 60 s
<b>Diagnostics</b>	Using LEDs	5 LEDs on the card: "Power", "L.RUN" (Running), "SD" (Send Data), "RD" (Receive Data), "L.ERR" (Error)
	Using the graphic display terminal or the PowerSuite software workshop	Transmission speed used Drive address

#### Characteristics of the Modbus/Uni-Telway card VW3 A3 303

<b>Structure</b>	Connector	One 9-way female SUB-D connector
	Transmission speed	Configurable via the display terminal or the PowerSuite software workshop: <ul style="list-style-type: none"> <li>■ 4800 bps</li> <li>■ 9600 bps</li> <li>■ 19200 bps</li> </ul>
	Polarization	Type of polarization can be configured using switches on the card: <ul style="list-style-type: none"> <li>■ No polarization impedances (supplied by the wiring system, for example, in the master)</li> <li>■ Two 4.7 kΩ</li> </ul>
	Selection of the protocol	Via the display terminal or the PowerSuite software workshop: <ul style="list-style-type: none"> <li>■ Modbus RTU</li> <li>■ Modbus ASCII</li> <li>■ Uni-Telway</li> </ul>
<b>Services</b>	Device profiles	CiA 402 profile: "Device Profile Drives and Motion Control" I/O profile
	Communication monitoring	Can be inhibited Time out fixed at 10 s
<b>Diagnostics</b>	Using LEDs	2 LEDs on the card: "RUN" (status) and "ERR" (fault)
	Using the graphic display terminal	Control word received Reference received

#### Characteristics of the Modbus protocol (1)

<b>Structure</b>	Physical interface	2-wire RS 485, 4-wire RS 485
	Transmission mode	RTU, ASCII
	Format	Configurable via the display terminal or the PowerSuite software workshop: In RTU mode only: <ul style="list-style-type: none"> <li>■ 8 bits, odd parity, 1 stop</li> <li>■ 8 bits, no parity, 1 stop</li> <li>■ 8 bits, even parity, 1 stop</li> <li>■ 8 bits, no parity, 2 stop</li> </ul> In RTU and ASCII modes: <ul style="list-style-type: none"> <li>■ 7 bits, even parity, 1 stop</li> <li>■ 7 bits, odd parity, 1 stop</li> <li>■ 7 bits, even parity, 2 stop</li> <li>■ 7 bits, odd parity, 2 stop</li> </ul>
	Address	1 to 247, configurable using switches on the card.
<b>Service</b>	Messaging	Read Holding Registers (03), 63 words maximum Read Input Registers (04), 63 words maximum Write Single Register (06) Write Multiple Registers (16), 61 words maximum Read/Write Multiple Registers (23) Read Device Identification (43) Diagnostics (08)

#### Characteristics of the Uni-Telway protocol (2)

<b>Structure</b>	Physical interface	2-wire RS 485
	Format	8 bits, odd parity, 1 stop
	Address	1 to 147, configurable using switches on the card.
<b>Service</b>	Messaging	Read word (04h) Write word (14h) Read object (36h), 63 words maximum Write object (37h), 60 words maximum Identification (0Fh) Protocol version (30h) Mirror (FAh) Read error counters (A2h) Reset counters (A4h)

(1) For the Modbus serial link, see pages 298 to 301.

(2) For the Uni-Telway serial link, see pages 306 and 307.

#### Characteristics of the Profibus DP card VW3 A3 307

<b>Structure</b>	Connector	One 9-way female SUB-D connector
	Transmission speed	9600 bps, 19.2 kbps, 93.75 kbps, 187.5 kbps, 500 kbps, 1.5 Mbps, 3 Mbps, 6 Mbps or 12 Mbps
	Address	1 to 126, configurable using switches on the card
<b>Services</b>	I/O data	PPO type 5 8 control variables which can be assigned by communication scanner 8 monitoring variables which can be assigned by communication scanner Indexed periodic variable (adjustments)
	Device profiles	CiA 402 profile: "Device Profile Drives and Motion Control" I/O profile
	Communication monitoring	Can be inhibited Time out can be set via the PROFIBUS DP network configurator
<b>Diagnostics</b>	Using LEDs	2 LEDs on the card: "ST" (status) and "DX" (data exchange)
	Using the graphic display terminal	Control word received Reference received I/O data (communication scanner)
<b>Description file</b>	A single gsd file is supplied for the whole range on the documentation CD-ROM or can be downloaded from the website "www.telemecanique.com". This file does not contain the description of the drive parameters.	

#### Characteristics of the LonWORKS card VW3 A3 312

<b>Structure</b>	Connector	1 removable 3-way screw connector
	Topology	TP/FT-10 (free topology)
	Transmission speed	78 kbps
<b>Services</b>	Device profiles	LONMARK 6010: Variable Speed Motor Drive LONMARK 0000: Node Object
<b>Diagnostics</b>	Using LEDs	3 LEDs on the card: "Service", "Status", "Fault"
	Using the graphic display terminal	Control word received Reference received
<b>Description file</b>	An xif file is supplied on the documentation CD-ROM or can be downloaded from the website "www.telemecanique.com".	

#### Characteristics of the METASYS N2 card VW3 A3 313

<b>Structure</b>	Connector	One 9-way female SUB-D connector
<b>Diagnostics</b>	Using LEDs	2 LEDs on the card: "COM" (network traffic) and "ERR" (fault)
	Using the graphic display terminal	Control word received Reference received

#### Characteristics of the APOGEE FLN card VW3 A3 314

<b>Structure</b>	Connector	One 9-way female SUB-D connector
<b>Diagnostics</b>	Using LEDs	2 LEDs on the card: "COM" (network traffic) and "ERR" (fault)
	Using the graphic display terminal	Control word received Reference received

#### Characteristics of the BACnet card VW3 A3 315

<b>Structure</b>	Connector	One 9-way female SUB-D connector
<b>Diagnostics</b>	Using LEDs	2 LEDs on the card: "COM" (network traffic) and "ERR" (fault)
	Using the graphic display terminal	Control word received Reference received



# Variable speed drives

## Altivar 61

### Communication buses and networks

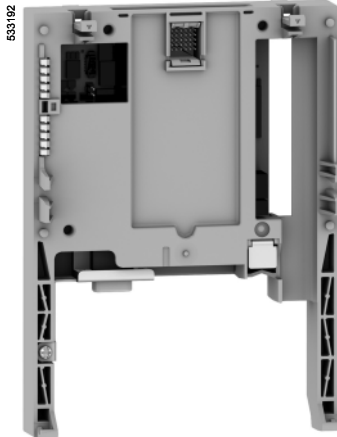

VW3 A3 311



TSX FP ACC12

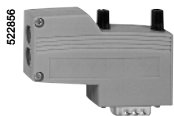

490 NAD 911 03

#### Communication cards (1) (2)

Description	Use	Reference	Weight kg
<b>Modbus TCP (3)</b>	To be connected on a Hub or Switch using cordset 490 NTW 000 ●●. See pages 292 and 293	<b>VW3 A3 310</b>	0.300
<b>Ethernet/IP</b>	To be connected on a Hub or Switch using cordset 490 NTW 000 ●●. See pages 292 and 293	<b>VW3 A3 316</b>	0.300
<b>Fipio</b>	To be connected using connector TSX FP ACC 12 with extension cable TSX FP CC●● or drop cable TSX FP CA●●. See pages 292 and 293	<b>VW3 A3 311</b>	0.300
<b>Modbus Plus</b>	To be connected to the IP 20 Modbus Plus tap 990 NAD 230 00 using cordset 990 NAD 219●0. See pages 304 and 305	<b>VW3 A3 302</b>	0.300
<b>DeviceNet</b>	The card is equipped with a removable 5-way screw terminal block.	<b>VW3 A3 309</b>	0.300
<b>INTERBUS</b>	To be connected using cordset 170 MCI ●●●00 (4)	<b>VW3 A3 304</b>	0.300
<b>CC-LINK</b>	The card is equipped with a removable 5-way screw terminal block.	<b>VW3 A3 317</b>	0.300
<b>Modbus/ Uni-Telway</b>	To be connected on subscriber socket TSX SCA 62 using cordset VW3 A8 306 2. See pages 300 and 307	<b>VW3 A3 303</b>	0.300
<b>PROFIBUS DP</b>	To be connected using connector 490 NAD 911●● to the PROFIBUS cable TSX PBS CA●00 (4)	<b>VW3 A3 307</b>	0.300
<b>LonWORKS</b>	The card is equipped with a removable 3-way screw terminal block	<b>VW3 A3 312</b>	0.300
<b>METASYS N2</b>	The card is equipped with one 9-way male SUB-D connector	<b>VW3 A3 313</b>	0.300
<b>APOGEE FLN</b>	The card is equipped with one 9-way male SUB-D connector	<b>VW3 A3 314</b>	0.300
<b>BACnet</b>	The card is equipped with one 9-way male SUB-D connector	<b>VW3 A3 315</b>	0.300

(1) The Altivar 61 drive can only take one communication card. Consult the summary tables of possible drive, option and accessory combinations on pages 170 to 179.

(2) The user manuals are supplied on CD-ROM or can be downloaded from the website "www.telemecanique.com". For the PROFIBUS DP, DeviceNet and LonWORKS cards, the description files in gsd, eds or xif format are also supplied on CD-ROM or can be downloaded from the website "www.telemecanique.com".

(3) Please refer to the "Ethernet TCP/IP Transparent Ready" catalogue.

(4) Please refer to the "Automation platform Modicon Premium and Unity - PL7 software" catalogue.

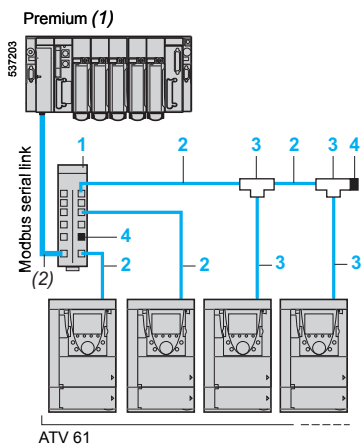

Example of Modbus diagram, connections via splitter boxes and RJ45 connectors

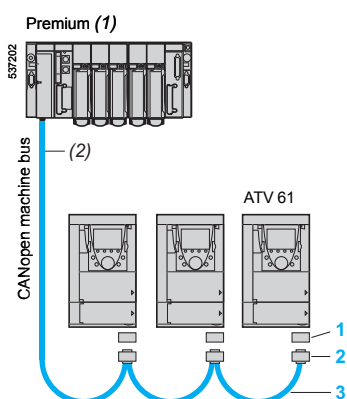

Example of CANopen diagram



VW3 CAN A71



VW3 CAN KCDF 180 T

#### Connection accessories

Description	No.	Length m	Unit reference	Weight kg	
<b>Modbus serial link</b>					
<b>Modbus splitter box</b> 10 RJ45 connectors and 1 screw terminal block	1	–	LU9 GC3	0.500	
<b>Cordsets for Modbus serial link</b> with 2 RJ45 connectors	2	0.3	VW3 A8 306 R03	0.025	
	1		VW3 A8 306 R10	0.060	
	3		VW3 A8 306 R30	0.130	
<b>Modbus T-junction boxes</b> (with integrated cable)	3	0.3	VW3 A8 306 TF03	0.190	
	1		VW3 A8 306 TF10	0.210	
<b>Line terminators</b> For RJ45 connector (3)	R = 120 Ω	4	–	VW3 A8 306 RC	0.010
	C = 1 nf				
	R = 150 Ω	4	–	VW3 A8 306 R	0.010

Description	No.	Length m	Reference	Weight kg
<b>CANopen machine bus (4)</b>				
<b>CANopen adapter</b> to be mounted on the RJ45 socket in the drive control terminals. The adapter provides a 9-way male SUB-D connector conforming to the CANopen standard (CIA DRP 303-1)	1	–	VW3 CAN A71	–
<b>CANopen connector (5)</b> 9-way female SUB-D with line terminator (can be disabled) 180° cable outlet for 2 CANopen cables. CAN-H, CAN-L, CAN-GND connection.	2	–	VW3 CAN KCDF 180T	–
<b>CANopen cables (1)</b> Standard cable, C€ marking Low smoke emission, halogen-free Flame retardant (IEC 60332-1)	3	50	TSX CAN CA 50	4.930
		100	TSX CAN CA 100	8.800
		300	TSX CAN CA 300	24.560
<b>CANopen cables (1)</b> UL certification, C€ marking Flame retardant (IEC 60332-2)	3	50	TSX CAN CB 50	3.580
		100	TSX CAN CB 100	7.840
		300	TSX CAN CB 300	21.870
<b>CANopen cables (1)</b> Cable for harsh environments (6) or mobile installation, C€ marking Low smoke emission, halogen-free. Flame retardant (IEC 60332-1)	3	50	TSX CAN CD 50	3.510
		100	TSX CAN CD 100	7.770
		300	TSX CAN CD 300	21.700

(1) Please refer to our specialist "Automation platform Modicon Premium and Unity - PL7 software" and "Automation platform Modicon TSX Micro - PL7 software" catalogues.

(2) Cable dependent on the type of controller or PLC.

(3) Sold in lots of 2.

(4) Please refer to the "Machines and installations with CANopen" catalogue.

(5) For ATV 61H●●●M3, ATV 61HD11M3X, HD15M3X, ATV 61H075N4...HD18N4 and ATV 61H●●●Y drives, this connector can be replaced by the TSX CAN KCDF 180T connector.

(6) Harsh environments:

- resistance to hydrocarbons, industrial oils, detergents, solder splashes
- relative humidity up to 100%
- saline atmosphere
- significant temperature variations
- operating temperature between - 10°C and + 70°C.

**Presentation**

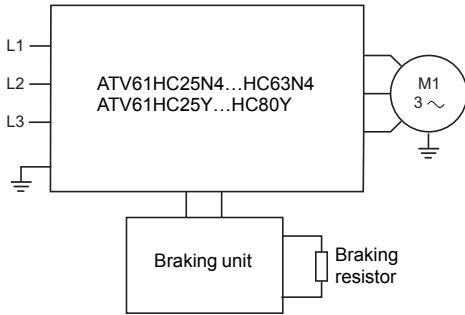

Resistance braking enables the Altivar 61 drive to operate while braking to a standstill or during "generator" operation, by dissipating the energy in the braking resistor.

ATV 61H●●●M3, ATV 61H●●●M3X, ATV 61H075N4...HC22N4, ATV 61W●●●N4, ATV 61W●●●N4C and ATV 61HU30Y...HC20Y drives have a built-in dynamic brake transistor.

For ATV 61HC25N4...HC63N4 and ATV 61HC25Y...HC80Y drives, a braking unit must be used. This is controlled by the drive:

- For ATV 61HC25N4, HC31N4 drives, the braking unit is mounted directly on the left-hand side of the drive, see dimensions on pages 181 and 183
- For ATV 61HC40N4...HC63N4 and ATV 61HC25Y...HC80Y drives, the braking unit is an external module, see dimensions on page 194

**Application**

High-inertia machines.

**Characteristics**

Type of braking unit			VW3 A7 101	VW3 A7 102	VW3 A7 103	VW3 A7 104
Ambient air temperature around the unit	Operation	°C	- 10...+ 50			
	Storage	°C	- 25...+ 70			
Degree of protection of casing			IP 20			
Degree of pollution			2 according to standard EN 50178			
Relative humidity			Class 3K3 without condensation			
Maximum operating altitude		m	2000		1000 1000...2260 by derating the continuous power of the braking unit by 1% per additional 100 m.	
Vibration resistance			0.2 gn			
Nominal voltage of line supply and drive supply (rms value)		V	380 ~ - 15%...480 ~ + 10%		500 ~ - 15%...690 ~ + 10%	
Engage threshold		V	785 ± 1%		1075 ± 1%	
Maximum DC bus voltage		V	850		1100	
Maximum braking power on 400 V ~ line supply	400 V ~ Line supply (785 V ± (1))	kW	420	750	-	
	690 V ~ Line supply (1075 V ± (1))	kW	-		450	900
Percentage of conduction time	At constant power at 785 V ±		5% at 420 kW	5% at 750 kW		
			15% at 320 kW	15% at 550 kW		
			50% at 250 kW	50% at 440 kW		
	At constant power at 1075 V ±				5% at 450 kW	5% at 900 kW
					15% at 400 kW	15% at 600 kW
					50% at 350 kW	50% at 500 kW
Cycle time		s	≤ 240		≤ 140	
Maximum continuous power		kW	200	400	300	400
Thermal protection			Integrated, via thermal probe			
Forced ventilation		m³/h	100	600		
Mounting			Vertical			
Minimum resistance value to be associated with the braking unit		Ω	1.05	0.7	2	1

(1) Braking unit engage threshold.

## Variable speed drives

Altivar 61

Option: resistance braking units

Braking units									
For drives	Power		Loss	Cable (drive-braking unit)		Cable (braking unit-resistors)		Reference	Weight
	Contin.	Max.	Con- tinuous power	Cross- section	Max. length	Cross- section	Max. length		
	kW	kW							
<b>Supply voltage: 380...480 V 50/60 Hz</b>									
ATV 61HC25N4, HC31N4	200	420	550	–	–	2 x 95	50	<b>VW3 A7 101</b>	30.000
				Internal connections					
ATV 61HC40N4... HC63N4	400	1050	750	2 x 150	1	2 x 150	50	<b>VW3 A7 102</b>	80.000
<b>Supply voltage: 500...690 V 50/60 Hz</b>									
ATV 61HC25Y... HC40Y	300	450	650	2 x 150	1	2 x 150	50	<b>VW3 A7 103</b>	80.000
ATV 61HC50Y... HC80Y	400	900	1150	2 x 150	1	2 x 150	50	<b>VW3 A7 104</b>	80.000

**Note:** To increase the braking power, several braking resistors can be mounted in parallel on the same braking unit. In this case, do not forget to take account of the minimum resistance value on each unit, see characteristics on page 136.

### Presentation

The braking resistor enables the Altivar 61 drive to operate while braking to a standstill, by dissipating the braking energy. It enables maximum transient braking torque.

The resistors are designed to be mounted on the outside of the enclosure, but should not inhibit natural cooling. Air inlets and outlets must not be obstructed in any way. The air must be free of dust, corrosive gas and condensation.

### Application

Inertia machines.

### General characteristics

Type of braking resistor			VW3 A7 701...709	VW3 A7 710...718	VW3 A7 805, 806	VW3 A7 814, 816
Ambient air temperature around the device	Operation	°C	0...+ 50			
	Storage	°C	- 25...+ 70		- 25...+ 75	- 25...+ 65
Degree of protection of casing			IP 20	IP 23		
Thermal protection			Via temperature-controlled switch or via the drive	Via thermal overload relay		
Temperature-controlled switch (1)	Tripping temperature	°C	120	–		
	Max. voltage - max. current		250 V ~	–		
	Min. voltage - min. current		24 V --- - 0.1 A	–		
	Maximum contact resistance	mW	60	–		
Load factor for the dynamic brake transistors			The internal circuits of Altivar 61 drives rated 200 kW or less have a built-in dynamic brake transistor			
	ATV 61H●●●M3, ATV 61H●●●M3X, ATV 61H075N4...HD75N4, ATV 61HU30Y...HD90Y, ATV 61W075N4...WD90N4, ATV 61W075N4C...WD90N4C		The dynamic brake transistor is sized so that it can tolerate 120% of the nominal motor power for 60 s.			
	ATV 61HD90N4...HC22N4		The dynamic brake transistor is sized so that it can tolerate 110% of the nominal motor power for 60 s.			
	ATV 61HC11Y...HC80Y		The dynamic brake transistor is sized so that it can tolerate 125% of the nominal motor power for 10 s.			

### Connection characteristics

Type of terminal		Drive connection	Temperature-controlled switch
Maximum wire size	VW3 A7 701...703	4 mm <sup>2</sup> (AWG 28)	1.5 mm <sup>2</sup> (AWG 16)
	VW3 A7 704...709	Connected on a bar, M6	2.5 mm <sup>2</sup> (AWG 14)
	VW3 A7 710...718, 805, 806, 814 and 816	Connected on a bar, M10	–

(1) The contact should be connected in the sequence (use for signalling, or in line contactor control).

**Minimum ohmic value of the resistors to be used with the Altivar 61 drive, at 20°C (1)**

**ATV 61H●●●M3, ATV 61H●●●M3X, ATV 61H●●●N4 and ATV 61H●●●Y drives**

Drive type	ATV 61H	075M3	U15M3	U22M3, U30M3	U40M3	U55M3	U75M3				
Minimum value	Ω	44	33	22	16	11	8				
Drive type	ATV 61H	D11M3X, D15M3X	D18M3X	D22M3X, D30M3X	D37M3X... D75M3X	D90M3X					
Minimum value	Ω	3	4	3.3	1.7	1.3					
Drive type	ATV 61H	075N4... U22N4	U30N4, U40N4	U55N4	U75N4	D11N4	D15N4, D18N4	D22N4, D30N4	D37N4	D45N4, D55N4	D75N4
Minimum value	Ω	56	34	23	19	12	7	13.3	6.7	5	3.3
Drive type	ATV 61H	D90N4, C11N4	C13N4... C22N4	C25N4, C31N4	C40N4...C63N4						
Minimum value	Ω	2.5	1.9	1.05	0.7						
Drive type	ATV 61H	U30Y... D45Y	D55Y, D75Y	D90Y	C11Y... C20Y	C25Y... C40Y	C50Y...C80Y				
Minimum value	Ω	12	8	5	4	2	1				

**ATV 61W●●●N4 and ATV 61W●●●N4C drives**

Drive type	ATV 61W	075N4... U30N4	U40N4, U55N4	U75N4	D11N4	D15N4	D18N4, D22N4	D30N4, D37N4	D45N4	D55N4, D75N4	D90N4
Minimum value	Ω	56	34	23	19	12	7	13.3	6.7	5	3.3
Drive type	ATV 61W	075N4C... U30N4C	U40N4C, U55N4C	U75N4C	D11N4C	D15N4C	D18N4C, D22N4C	D30N4C, D37N4C	D45N4C	D55N4C, D75N4C	D90N4C
Minimum value	Ω	56	34	23	19	12	7	13.3	6.7	5	3.3

(1) The minimum ohmic value is determined at a temperature of 20°C. In an environment where the temperature is below 20°C, make sure that the minimum ohmic value recommended in the table is observed.

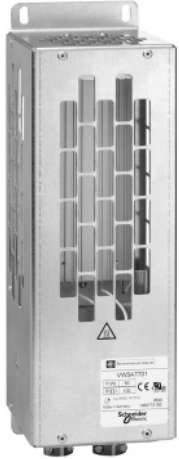

VW3 A7 701

## Braking resistors

For drives	Ohmic value at 20 °C	Average power available at 50°C (1)	Reference	Weight
	Ω	kW		kg
<b>Supply voltage: 200...240 V 50/60 Hz</b>				
ATV 61H075M3	100	0.05	<b>VW3 A7 701</b>	1.900
ATV 61HU15M3, HU22M3	60	0.1	<b>VW3 A7 702</b>	2.400
ATV 61HU30M3, HU40M3	28	0.2	<b>VW3 A7 703</b>	3.500
ATV 61HU55M3, HU75M3	15	1	<b>VW3 A7 704</b>	11.000
ATV 61HD11M3X	10	1	<b>VW3 A7 705</b>	11.000
ATV 61HD15M3X	8	1	<b>VW3 A7 706</b>	11.000
ATV 61HD18M3X, HD22M3X	5	1.3	<b>VW3 A7 707</b>	11.000
ATV 61HD30M3X	4	1	<b>VW3 A7 708</b>	11.000
ATV 61HD37M3X, HD45M3X	2.5	1	<b>VW3 A7 709</b>	11.000
ATV 61HD55M3X, HD75M3X	1.8	15.3	<b>VW3 A7 713</b>	50.000
ATV 61HD90M3X	1.4	20.9	<b>VW3 A7 714</b>	63.000
<b>Supply voltage: 380...480 V 50/60 Hz</b>				
ATV 61H075N4...HU40N4 ATV 61W075N4...WU55N4 (2) ATV 61W075N4C...WU55N4C (2)	100	0.05	<b>VW3 A7 701</b>	1.900
ATV 61HU55N4, HU75N4 ATV 61WU75N4, WD11N4 (2) ATV 61WU75N4C, WD11N4C (2)	60	0.1	<b>VW3 A7 702</b>	2.400
ATV 61HD11N4, HD15N4 ATV 61WD15N4, WD18N4 (2) ATV 61WD15N4C, WD18N4C (2)	28	0.2	<b>VW3 A7 703</b>	3.500
ATV 61HD18N4...HD30N4 ATV 61WD22N4...WD37N4 (2) ATV 61WD22N4C...WD37N4C (2)	15	1	<b>VW3 A7 704</b>	11.000
ATV 61HD37N4 ATV 61WD45N4 (2) ATV 61WD45N4C (2)	10	1	<b>VW3 A7 705</b>	11.000
ATV 61WD55N4...WD90N4 (2) ATV 61WD55N4C...WD90N4C (2)	8	1	<b>VW3 A7 706</b>	11.000
ATV 61HD45N4...HD75N4	5	1.3	<b>VW3 A7 707</b>	11.000
ATV 61HD90N4, HC11N4	2.75	25	<b>VW3 A7 710</b>	80.000
ATV 61HC13N4, HC16N4	2.1	37	<b>VW3 A7 711</b>	86.000
ATV 61HC22N4	2.1	44	<b>VW3 A7 712</b>	104.000
ATV 61HC25N4	1.05	56	<b>VW3 A7 715</b>	136.000
ATV 61HC31N4	1.05	75	<b>VW3 A7 716</b>	172.000
ATV 61HC40N4, HC50N4	0.7	112	<b>VW3 A7 717</b>	266.000
ATV 61HC63N4	0.7	150	<b>VW3 A7 718</b>	350.000

(1) Load factor for resistors: the value of the average power that can be dissipated at 50°C from the resistor into the enclosure is determined for a load factor during braking that corresponds to the majority of normal applications.

For VW3 A7 701...709:

- 2 s braking with a 0.6 T<sub>n</sub> braking torque for a 40 s cycle
- 0.8 s braking with a 1.5 T<sub>n</sub> braking torque for a 40 s cycle

For VW3 A7 710...718:

- 10 s braking with a 2 T<sub>n</sub> braking torque for a 30 s cycle

(2) The degree of protection for the braking resistors is IP 20.

## Variable speed drives

Altivar 61

Option: braking resistors

Braking resistors (continued)					
Supply voltage: 500...690 V 50/60 Hz					
For drives	Ohmic value at 20 °C	Average power available at 50°C (1)	Quantity per drive	Reference	Weight
	Ω	kW			kg
ATV 61HU30Y...HU75Y	100	0.05	1	VW3 A7 701	1.900
ATV 61HD11Y, HD15Y	60	0.1	1	VW3 A7 702	2.400
ATV 61HD18Y, HD22Y	28	0.2	1	VW3 A7 703	3.500
ATV 61HD30Y...HD45Y	15	1	1	VW3 A7 704	11.000
ATV 61HD55Y, HD75Y	10	1	1	VW3 A7 705	11.000
ATV 61HD90Y	5	1.3	1	VW3 A7 707	11.000
ATV 61HC11Y, HC13Y	4.2	62	1	VW3 A7 806	126.000
ATV 61HC16Y, HC20Y	8.1	44	2	VW3 A7 805 (2)	92.000
ATV 61HC25Y	4.2	62	2	VW3 A7 806 (2)	126.000
ATV 61HC31Y	1.05	75	2	VW3 A7 716 (3)	172.000
ATV 61HC40Y	1.05	112	2	VW3 A7 814 (3)	280.000
ATV 61HC50Y	0.7	112	2	VW3 A7 717 (3)	266.000
ATV 61HC63Y	0.7	150	2	VW3 A7 718 (3)	350.000
ATV 61HC80Y	0.7	225	2	VW3 A7 816 (3)	543.000

(1) Load factor for resistors: the value of the average power that can be dissipated at 50°C from the resistor into the enclosure is determined for a load factor during braking that corresponds to the majority of normal applications.

For VW3 A7 701...705 and 707:

- 2 s braking with a 0.6 T<sub>n</sub> braking torque for a 40 s cycle

- 0.8 s braking with a 1.5 T<sub>n</sub> braking torque for a 40 s cycle

For VW3 A7 716...718:

- 10 s braking with a 2 T<sub>n</sub> braking torque for a 30 s cycle

For VW3 A7 805 and 806:

- 100 s braking with a 1 T<sub>n</sub> braking torque for a 200 s cycle

- 20 s braking with a 1.6 T<sub>n</sub> braking torque for a 200 s cycle

For VW3 A7 814 and 816:

- 10 s braking with a 2 T<sub>n</sub> braking torque for a 240 s cycle

- 110 s braking with a 1.25 T<sub>n</sub> braking torque for a 240 s cycle

(2) To be connected in parallel; check the required dimensions, see page 196.

(3) To be connected in series; check the required dimensions, see page 195.



# Variable speed drives

## Altivar 61

### Option: braking units and resistors

#### Determining the braking unit and resistor

Calculating the various braking powers makes it possible to determine the braking unit and the braking resistor.

#### Operation

The braking power during deceleration is characterized by a peak power  $\hat{P}_b$  obtained at the start of deceleration, which decreases to 0 in proportion to the speed.

**For example:** Stopping centrifuges, ventilation, change of direction, etc.

- $n_1$  Motor speed
- $T_l$  Load torque
- $T_b$  Braking torque
- $\hat{P}_f$  Maximum braking power
- $\bar{P}_b$  Average braking power during  $t_b$
- $t_b$  Braking time

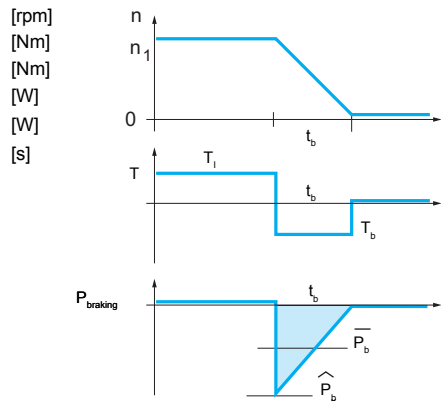

#### Calculating the braking time from the inertia

$t_b = \frac{J \cdot \omega}{T_b + T_r}$	$\omega = \frac{2\pi \cdot n}{60}$	$T_b = \frac{\Sigma J \cdot (n_3 - n_4)}{9.55 \cdot t_b}$	$\hat{P}_b = \frac{T_b \cdot n_3}{9.55}$
			$\bar{P}_b = \frac{\hat{P}_b}{2}$

- $T_b$  Motor braking torque
- $\Sigma J$  Total inertia applied to the motor
- $n$  Motor speed
- $n_3$  Motor speed ahead of gearbox
- $n_4$  Motor speed after gearbox
- $t_b$  Braking time
- $\hat{P}_f$  Peak braking power
- $\bar{P}_b$  Average braking power during time  $t_b$
- $T_r$  Resistive torque

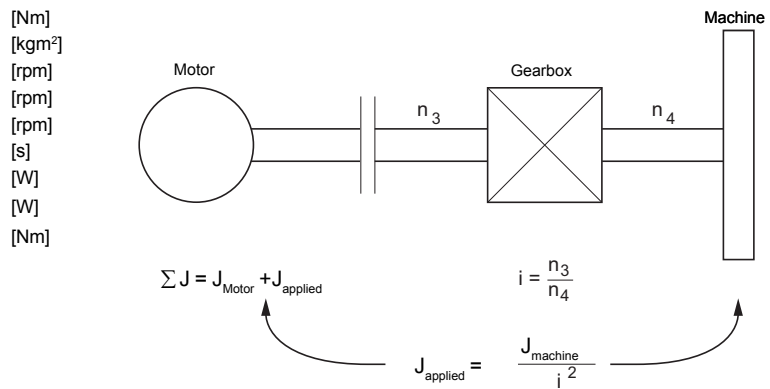

#### Example of using characteristic curves

VW3 A7 710 (continuous power = 25 kW) for 2.75 Ω at 20°C

Example of how to use the curves:

**Point A** For a 200 s cycle, the resistance of 2.75 Ω accepts an overload of 7 x 25 kW (continuous power) for 24 s, i.e. braking 175 kW every 200 s.

**Point B** For a 120 s cycle, the resistance of 2.75 Ω accepts an overload of 5 x 25 kW (continuous power) for 20 s, i.e. braking 125 kW every 120 s.

**Point C** For a 60 s cycle, the resistance of 2.75 Ω accepts an overload of 5 x 25 kW (continuous power) for 10 s, i.e. braking 125 kW every 60 s.

- Pmax/Pav (60 s cycle)
- - - Pmax/Pav (120 s cycle)
- Pmax/Pav (200 s cycle)

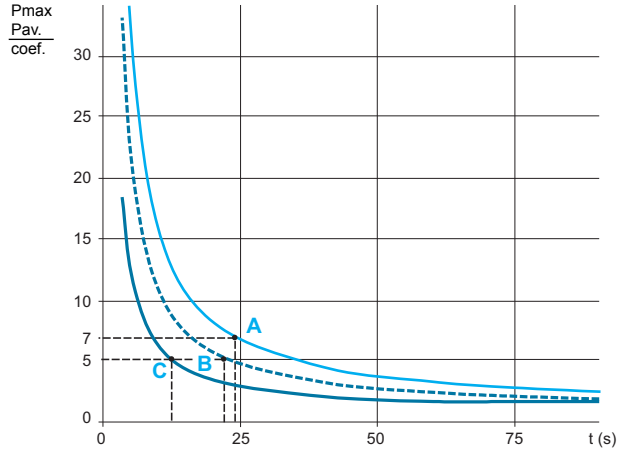

#### Braking resistors

VW3 A7 701 (continuous power = 0.05 kW)

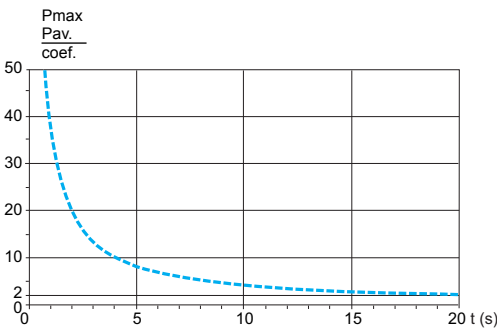

VW3 A7 702 (continuous power = 0.1 kW)

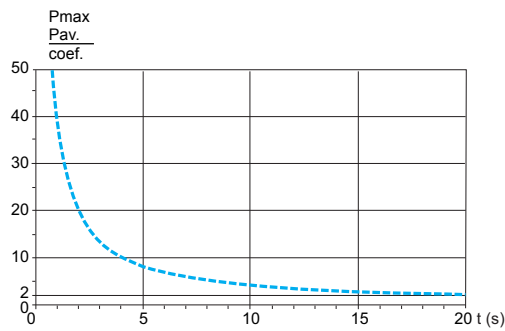

VW3 A7 703 (continuous power = 0.2 kW)

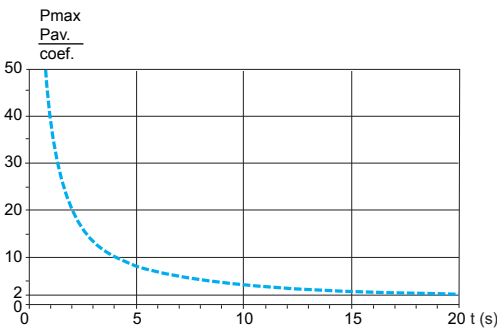

VW3 A7 704...706 (continuous power = 1 kW)

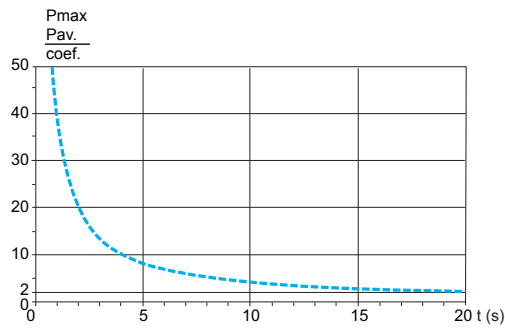

VW3 A7 707 (continuous power = 1.3 kW)

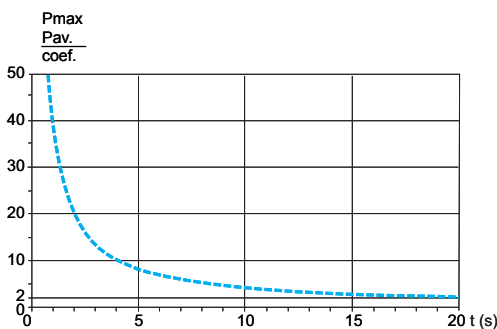

VW3 A7 708, 709 (continuous power = 1 kW)

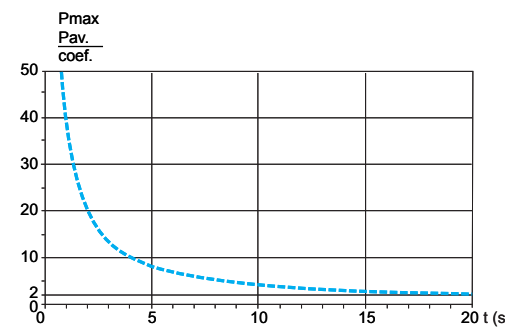

--- Pmaxi/Pmoy (cycle 40 s)

#### Braking resistors (continued)

**VW3 A7 710 (continuous power = 25 kW)**

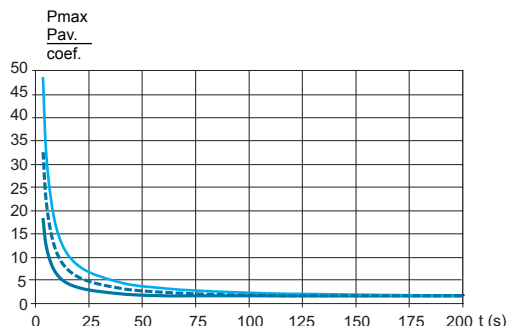

**VW3 A7 711 (continuous power = 37 kW)**

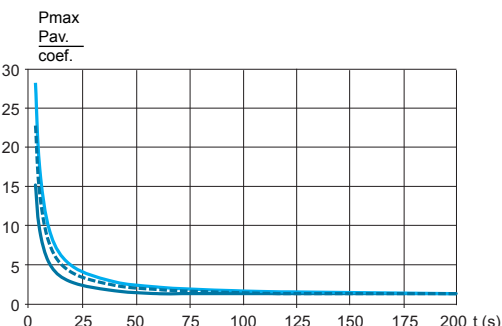

**VW3 A7 712 (continuous power = 44 kW)**

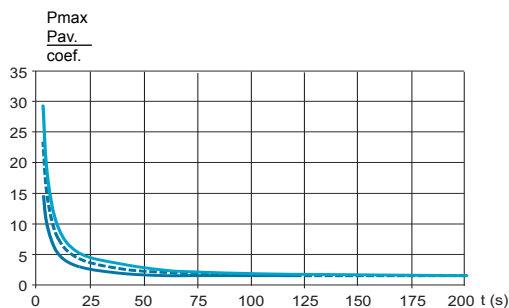

**VW3 A7 713 (continuous power = 15.3 kW)**

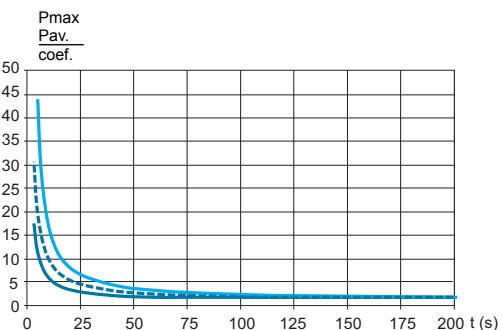

**VW3 A7 714 (continuous power = 20.9 kW)**

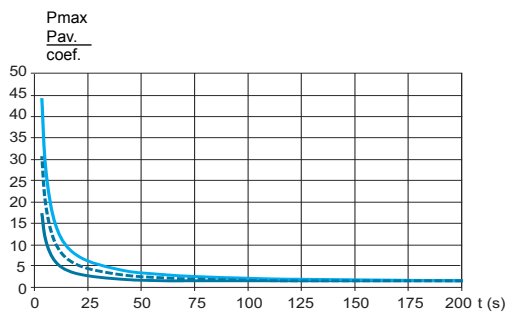

**VW3 A7 715 (continuous power = 56 kW)**

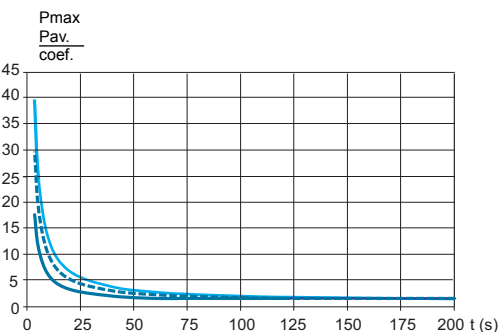

**VW3 A7 716 (continuous power = 75 kW)**

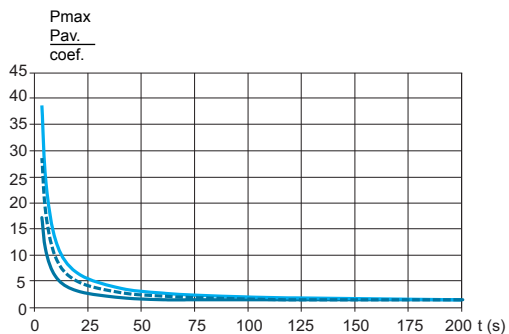

**VW3 A7 717 (continuous power = 112 kW)**

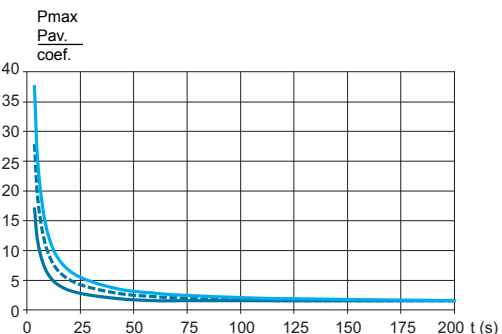

- $P_{max}/P_{av}$  (60 s cycle)
- - -  $P_{max}/P_{av}$  (120 s cycle)
- $P_{max}/P_{av}$  (200 s cycle)

#### Braking resistors (continued)

**VW3 A7 718 (continuous power = 150 kW)**

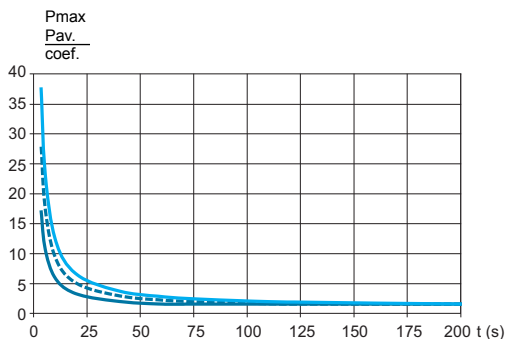

**VW3 A7 805 (continuous power = 44 kW)**

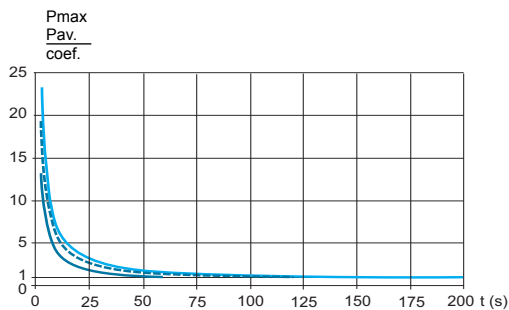

**VW3 A7 806 (continuous power = 62 kW)**

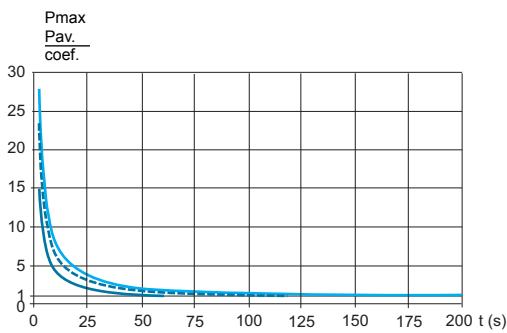

**VW3 A7 814 (continuous power = 112 kW)**

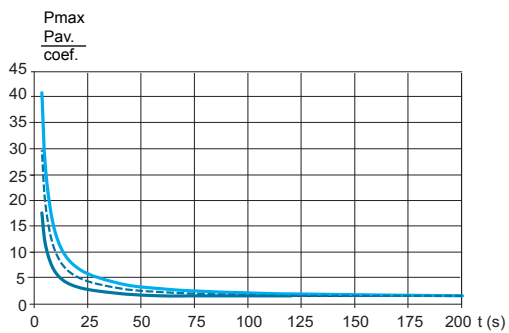

**VW3 A7 816 (continuous power = 225 kW)**

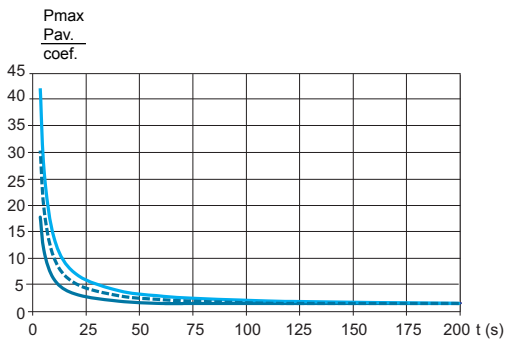

- $P_{max}/P_{av}$  (60 s cycle)
- - -  $P_{max}/P_{av}$  (120 s cycle)
- · ·  $P_{max}/P_{av}$  (200 s cycle)

# Variable speed drives

## Altivar 61: reduction of current harmonics

### Option: DC chokes

Depending on the line supply, the main solutions for reducing current harmonics are as follows:

- DC chokes, see below
- Line chokes (1), see page 150
- 16% and 10% passive filters, see page 155
- Use of passive filters with a DC choke, see pages 155 to 159.

These 4 solutions can be used on the same installation (1).

It is always easier and less expensive to deal with current harmonics at installation level as a whole rather than at the level of each individual unit, particularly when using passive filters and active compensators.

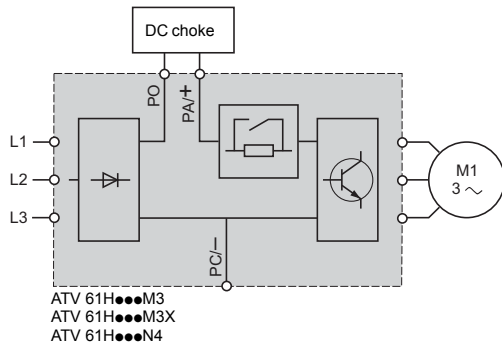

### DC chokes

DC chokes are used to reduce current harmonics in order to comply with standard IEC 61000-3-12 for drives in which the line current is more than 16 A and less than 75 A.

Using a DC choke with the drive complies with standard IEC 61000-3-12 provided that the  $RSCE \geq 120$  (2) at the point of connection to the public network. 120 represents the minimum value of RSCE (2) for which the values in table 4 of standard IEC 61000-3-12 are not exceeded.

It is the responsibility of the installer or the user to ensure that the device is connected correctly to a connection point with an  $RSCE \geq 120$ . The DC choke is connected to the drive power terminals.

It is supplied as standard with ATV 61HD55M3X...HD90M3X and ATV 61HD90N4...HC63N4 drives, and integrated in ATV 61W●●●N4 and ATV 61W●●●N4C drives.

### Applications

Reduction of current harmonics.

Reduction of the THD to 5% or 10% when used with passive filters, see pages 155 to 159.

Maintaining the motor torque in relation to the line choke.

(1) For ATV 61HU30Y...HD90Y drives, only line chokes are recommended.

For ATV 61HC11Y...HC80Y drives, a line choke is mandatory, see page 150.

(2) Short-circuit ratio.

### Example of current harmonic levels for ATV 61H075M3...ATV 61HD90M3X drives (1)

Motor power	For ATV 61 drives	Line supply		Current harmonic levels																THD (3)		
		Line current	Line Isc (2)	H1	H5	H7	H11	H13	H17	H19	H23	H25	H29	H31	H35	H37	H41	H43	H47		H49	
kW	HP	A	kA	A	%	%	%	%	%	%	%	%	%	%	%	%	%	%	%	%		
<b>Three-phase supply voltage: 230 V 50 Hz, with optional DC choke</b>																						
0.75	1	H075M3	3.05	5	2.81	31.99	20.91	8.88	7.36	5.6	4.63	4.07	3.42	3.18	2.71	2.59	2.24	2.17	1.91	1.86	1.66	41.27
1.5	2	HU15M3	6.04	5	5.55	33.65	21.59	8.14	6.84	4.97	4.19	3.54	3.08	2.71	2.43	2.17	2.01	1.78	1.7	1.5	1.47	42.4
2.2	3	HU22M3	8.33	5	7.64	34.89	21.11	8.78	6.72	5.36	4.1	3.8	3	2.9	2.37	2.29	1.95	1.85	1.66	1.52	1.44	43.33
3	-	HU30M3	11.12	5	10.19	35.17	20.68	8.71	6.48	5.24	3.94	3.67	2.88	2.76	2.27	2.15	1.87	1.71	1.58	1.37	1.37	43.22
4	5	HU40M3	14.53	5	13.29	36.23	20.51	8.73	6.2	5.2	3.73	3.61	2.71	2.68	2.14	2.06	1.76	1.61	1.49	1.27	1.28	43.91
5.5	7.5	HU55M3	19.2	8	17.9	30.68	17.26	8.75	6.31	5.3	4.03	3.72	2.98	2.79	2.36	2.17	1.94	1.71	1.63	1.36	1.4	38
7.5	10	HU75M3	26.1	15	23.9	35.23	21.09	8.82	6.71	5.38	4.09	3.82	2.98	2.91	2.35	2.31	1.92	1.87	1.63	1.54	1.4	43.96
11	15	HD11M3X	36.6	15	34.2	30.91	17.12	8.86	6.36	5.37	4.08	3.77	3.01	2.82	2.37	2.19	1.94	1.73	1.62	1.37	1.38	38.14
15	20	HD15M3X	48.6	15	45.8	28.3	14.9	8.8	6.2	5.3	4.1	3.7	3	2.7	2.4	2.1	1.9	1.6	1.6	1.2	1.3	35
18.5	25	HD18M3X	60	22	56	31.5	17.1	8.7	6.1	5.2	3.9	3.7	2.9	2.7	2.3	2.1	1.9	1.7	1.6	1.3	1.3	38.5
22	30	HD22M3X	70.28	22	65.92	29.81	15.91	8.7	6.15	5.23	3.99	3.63	2.95	2.68	2.32	2.04	1.89	1.57	1.57	1.22	1.32	36.62
30	40	HD30M3X	96.9	22	88.78	36.68	19.42	8.38	5.67	4.86	3.44	3.29	2.52	2.38	1.98	1.77	1.62	1.34	1.34	1.02	1.12	43.51
37	50	HD37M3X	116.1	22	107.9	33.09	16.4	8.59	5.59	4.97	3.54	3.33	2.6	2.36	2.03	1.72	1.63	1.26	1.32	0.94	1.06	39.24
45	60	HD45M3X	138.7	22	130.5	30.15	13.86	8.65	5.38	5.01	3.49	3.33	2.55	2.33	1.96	1.66	1.53	1.2	1.19	0.9	0.9	35.7
<b>Three-phase supply voltage: 230 V 50 Hz, with DC choke supplied as standard with the drive</b>																						
55	75	HD55M3X	120	14	109.29	39.77	18.67	7.98	4.67	4.16	2.59	2.61	1.81	1.76	1.35	1.23	1.02	0.87	0.78	0.63	0.59	45.36
75	100	HD75M3X	163	35	148.35	38.83	20.24	8.2	5.43	4.58	3.15	3.04	2.24	2.17	1.7	1.62	1.33	1.23	1.06	0.94	0.84	45.51
90	125	HD90M3X	196.06	35	177.16	40.75	21.04	8.1	5.26	4.42	2.93	2.88	2.06	2.04	1.55	1.49	1.21	1.12	0.95	0.85	0.75	47.41

### Example of current harmonic levels for ATV 61H075N4...ATV 61HC63N4 drives (1)

Motor power	For ATV 61 drives	Line supply		Current harmonic levels																THD (3)		
		Line current	Line Isc (2)	H1	H5	H7	H11	H13	H17	H19	H23	H25	H29	H31	H35	H37	H41	H43	H47		H49	
kW	HP	A	kA	A	%	%	%	%	%	%	%	%	%	%	%	%	%	%	%	%	%	
<b>Three-phase supply voltage: 400 V 50 Hz, with optional DC choke</b>																						
0.75	1	H075N4	1.77	5	1.61	34.6	23.7	8.9	7.8	5.6	4.8	4.1	3.5	3.2	2.8	2.6	2.3	2.2	1.9	1.9	1.7	44.95
1.5	2	HU15N4	3.34	5	3.03	35.55	23.53	8.95	7.65	5.61	4.74	4.06	3.49	3.16	2.76	2.57	2.28	2.15	1.94	1.83	1.68	45.48
2.2	3	HU22N4	4.83	5	4.4	35.79	22.77	8.7	7.11	5.41	4.36	3.89	3.2	3.01	2.53	2.43	2.09	2.01	1.77	1.7	1.53	45
3	-	HU30N4	6.13	5	5.67	31.61	18.82	9.41	6.82	5.88	4.57	4.24	3.38	3.28	2.67	2.63	2.19	2.16	1.86	1.8	1.6	40.08
4	5	HU40N4	8.24	5	7.51	36.16	21.63	9	8.17	5.52	4.17	3.93	3.05	3	2.4	2.38	1.98	1.93	1.68	1.58	1.45	44.72
5.5	7.5	HU55N4	10.81	22	9.83	34.85	23.08	9.68	6.05	6.12	5.18	4.45	3.83	3.48	3.04	2.85	2.52	2.4	2.14	2.06	1.85	45.19
7.5	10	HU75N4	15.01	10	13.8	34.09	20.49	8.57	6.43	5.28	3.95	3.78	2.89	2.9	2.28	2.32	1.88	1.9	1.59	1.58	1.37	42.25
11	15	HD11N4	21.1	9	19.3	35.22	20.11	8.95	6.5	5.41	4.02	3.8	2.95	2.86	2.32	2.23	1.9	1.77	1.6	1.42	1.37	43.1
15	20	HD15N4	28.2	12	25.8	35.22	20.01	8.98	6.49	5.43	4.02	3.82	2.94	2.88	2.32	2.24	1.9	1.78	1.6	1.43	1.37	43.06
18.5	25	HD18N4	33.9	12	31.9	28.36	15.16	8.85	6.18	5.39	4.04	3.78	2.98	2.83	2.34	2.18	1.9	1.7	1.58	1.33	1.33	35.23
22	30	HD22N4	40.87	22	37.85	32.79	18.73	8.6	6.42	5.28	4.09	3.75	3.03	2.85	2.4	2.25	1.97	1.81	1.67	1.48	1.44	40.4
30	40	HD30N4	54.1	20	50.6	29.97	16.26	8.75	6.27	5.32	4.07	3.73	3.01	2.79	2.25	2.15	1.94	1.69	1.62	1.33	1.38	36.99
37	50	HD37N4	66.43	22	62.6	28.49	15.01	8.63	6.08	5.23	4	3.65	2.97	2.71	2.34	2.07	1.9	1.61	1.58	1.26	1.32	35.13
45	60	HD45N4	83.11	22	75.56	38.31	20.96	8.24	5.81	4.85	3.48	3.33	2.54	2.44	2	1.85	1.64	1.42	1.38	1.1	1.17	45.59
55	75	HD55N4	98.6	22	91.69	32.94	16.76	8.5	5.68	4.98	3.62	3.38	2.67	2.44	2.09	1.81	1.69	1.37	1.39	1.04	1.14	39.29
75	100	HD75N4	134	22	125.9	30.65	14.43	8.4	5.4	4.84	3.52	3.21	2.59	2.25	2	1.61	1.58	1.17	1.25	0.88	0.96	36.2
<b>Three-phase supply voltage: 400 V 50 Hz, with DC choke supplied as standard with the drive</b>																						
90	125	HD90N4	158.81	35	145.1	36.72	20.66	8.33	6.19	4.93	3.78	3.43	2.75	2.56	2.13	1.99	1.72	1.59	1.4	1.29	1.16	44.26
110	150	HC11N4	188.59	35	175.53	33.15	16.56	8.29	5.6	4.81	3.57	3.26	2.58	2.36	1.97	1.77	1.53	1.36	1.2	1.04	0.95	39.26
132	200	HC13N4	226.53	35	209.69	34.91	17.14	8.21	5.36	4.66	3.33	3.11	2.4	2.22	1.82	1.64	1.41	1.24	1.1	0.94	0.86	40.86
160	250	HC16N4	271.34	50	251.7	34	17.22	8.28	5.59	4.8	3.51	3.23	2.56	2.35	1.94	1.76	1.51	1.34	1.2	1.04	0.95	40.24
200	300	HC22N4	337.95	50	313.51	34.38	16.75	8.23	5.33	4.65	3.32	3.09	2.39	2.2	1.81	1.63	1.38	1.22	1.07	0.91	0.84	40.24
220	350	HC22N4	369.49	50	344.77	32.98	15.54	8.23	5.26	4.66	3.33	3.07	2.39	2.17	1.79	1.57	1.35	1.16	1.03	0.86	0.79	38.53
250	400	HC25N4	418.15	50	390.95	32.69	14.89	8.15	5.14	4.56	3.26	2.98	2.32	2.07	1.71	1.48	1.29	1.07	0.97	0.78	0.72	37.95
280	450	HC31N4	471.17	50	437.41	34.78	15.9	8.1	4.92	4.44	3.04	2.86	2.16	1.97	1.6	1.4	1.21	1	0.9	0.72	0.67	40.05
315	500	HC31N4	526.6	50	492.29	33.1	14.44	8.08	4.85	4.41	3.05	2.81	2.15	1.9	1.57	1.32	1.15	0.92	0.84	0.65	0.61	37.99
355	-	HC40N4	591.92	50	554.81	32.59	13.7	8	4.73	4.32	2.99	2.71	2.09	1.8	1.5	1.22	1.08	0.84	0.78	0.57	0.55	37.2
400	600	HC40N4	660.94	50	622.77	31.23	12.61	7.95	4.71	4.26	2.99	2.63	2.06	1.71	1.45	1.12	1.01	0.75	0.7	0.51	0.49	35.57
500	700	HC50N4	834.65	50	781.47	33.52	13.05	7.75	4.28	3.97	2.65	2.37	1.82	1.49	1.26	0.96	0.88	0.63	0.61	0.43	0.42	37.54
560	800	HC63N4	930.84	50	874.82	32.5	12.37	7.76	4.28	3.96	2.67	2.34	1.78	1.46	1.21	0.86	0.79	0.56	0.54	0.39	0.38	36.39
630	900	HC63N4	1037.11	50	980.2	31.06	11.11	7.64	4.23	3.81	2.63	2.15	1.73	1.27	1.13	0.77	0.73	0.5	0.48	0.39	0.36	34.61

(1) Example of current harmonic levels up to harmonic order 49 for a 230 V 50 Hz line supply for ATV 61H●●●M3 and ATV 61H●●●M3X drives and a 400 V 50 Hz line supply for ATV 61H●●●N4 drives, with the chokes connected between the PO and PA+ terminals on the Altivar 61.

# Variable speed drives

## Altivar 61: reduction of current harmonics

Option: DC chokes

### Example of current harmonic levels for ATV 61W●●●N4 and ATV 61W●●●N4C drives (1)

Three-phase supply voltage: 400 V 50 Hz with integrated DC choke

Motor power	For ATV 61 drives	Line supply		Current harmonic levels																THD (3)		
		Line current	Line Isc (2)	H1	H5	H7	H11	H13	H17	H19	H23	H25	H29	H31	H35	H37	H41	H43	H47		H49	
kW	HP	A	kA	A	%	%	%	%	%	%	%	%	%	%	%	%	%	%	%	%	%	
0.75	1	W075N4 W075N4C	1.75	5	1.61	32.12	22.41	8.97	7.96	5.77	5	4.25	3.69	3.36	2.93	2.78	2.43	2.37	2.08	2.06	1.81	42.65
1.5	2	WU15N4 WU15N4C	3.38	5	3.08	34.84	23.58	8.77	7.71	5.60	4.77	4.11	3.51	3.24	2.78	2.67	2.30	2.26	1.96	1.96	1.71	45.12
2.2	3	WU22N4 WU22N4C	4.77	5	4.38	33.37	22.01	8.8	7.48	5.6	4.7	4.1	3.48	3.23	2.76	2.65	2.28	2.24	1.94	1.93	1.69	43.12
3	-	WU30N4 WU30N4C	6.39	5	5.84	35.07	22.41	8.51	7.38	5.36	4.63	3.89	3.43	3.04	2.73	2.48	2.26	2.08	1.93	1.79	1.67	44.48
4	5	WU40N4 WU40N4C	8.39	5	7.64	36.07	22.73	8.45	7.27	5.29	4.52	3.82	3.33	2.97	2.65	2.42	2.19	2.02	1.86	1.73	1.61	45.34
5.5	7.5	WU55N4 WU55N4C	10.71	22	9.9	30.94	21	9.56	8.22	6.09	5.31	4.47	3.94	3.52	3.14	2.9	2.6	2.45	2.21	2.11	1.92	41.41
7.5	10	WU75N4 WU75N4C	15.1	22	13.73	35.93	23.66	8.72	7.55	5.53	4.65	4.03	3.41	3.16	2.7	2.59	2.23	2.19	1.89	1.88	1.64	45.9
11	15	WD11N4 WD11N4C	20.75	22	19.35	29.81	18.76	9.1	7.38	5.76	4.79	4.2	3.56	3.29	2.83	2.69	2.34	2.26	1.99	1.93	1.72	38.88
15	20	WD15N4 WD15N4C	28.74	22	26.24	35.65	22.28	8.55	7.22	5.32	4.50	3.83	3.32	2.97	2.63	2.41	2.17	2.01	1.84	1.71	1.58	44.79
18.5	25	WD18N4 WD18N4C	35.41	22	32.11	37.49	23.29	8.44	7.13	5.22	4.36	3.74	3.19	2.88	2.52	2.32	2.08	1.93	1.75	1.63	1.51	46.65
22	30	WD22N4 WD22N4C	41.66	22	37.87	37.21	22.55	8.38	6.95	5.16	4.26	3.69	3.13	2.84	2.47	2.29	2.02	1.89	1.7	1.6	1.46	45.99
30	40	WD30N4 WD30N4C	54.02	22	50.77	29.05	16.24	8.66	6.55	5.39	4.32	3.86	3.22	2.96	2.55	2.36	2.09	1.92	1.76	1.59	1.5	36.54
37	50	WD37N4 WD37N4C	66.15	22	62.09	29.46	16.33	8.76	6.51	5.41	4.25	3.85	3.15	2.93	2.48	2.32	2.03	1.86	1.7	1.52	1.45	36.89
45	60	WD45N4 WD45N4C	80.82	22	75.33	31.82	17.26	8.57	6.24	5.22	4.02	3.69	2.97	2.78	2.34	2.18	1.91	1.73	1.59	1.39	1.35	38.98
55	75	WD55N4 WD55N4C	100.42	22	92.45	35.41	19.11	8.24	6.06	4.92	3.78	3.43	2.77	2.57	2.16	2	1.73	1.6	1.42	1.3	1.18	42.51
75	100	WD75N4 WD75N4C	133.88	22	125.86	30.11	14.93	8.5	5.85	5.07	3.82	3.49	2.81	2.56	2.19	1.92	1.76	1.46	1.43	1.12	1.18	36.35
90	125	WD90N4 WD90N4C	164.46	35	152.4	33.86	17.83	8.24	5.98	4.93	3.8	3.43	2.8	2.57	2.18	2	1.75	1.6	1.43	1.29	1.18	40.65

(1) Example of current harmonic levels up to harmonic order 49 for a 400 V 50 Hz line supply with chokes connected between the PO and PA/+ terminals on the Altivar 61.

(2) The line Isc values are given for the current harmonic levels stated in the table.

(3) Total harmonic distortion in accordance with IEC 61000-3-12.

General characteristics			
Degree of protection			IP 20
Maximum relative humidity			95%
Ambient air temperature around the device	Operation	°C	- 10...+ 50 without derating Up to 60°C with current derating of 2.2% per °C above 50°C
	Storage	°C	- 40...+ 65
Maximum operating altitude		m	1000 without derating 1000...3000 with current derating of 1% per additional 100 m
Voltage drop			4 to 6%
Maximum current			1.65 x nominal current for 60 seconds

Connection characteristics			
Type of terminal		Earth	Power supply
Maximum wire size and tightening torque	VW3 A4 501...505	10 mm <sup>2</sup> (AWG 6) 1.2...1.4 Nm	2.5 mm <sup>2</sup> (AWG 12) 0.4...0.6 Nm
	VW3 A4 506	10 mm <sup>2</sup> (AWG 6) 1.2...1.4 Nm	4 mm <sup>2</sup> (AWG 10) 0.5...0.8 Nm
	VW3 A4 507	10 mm <sup>2</sup> (AWG 6) 1.2...1.4 Nm	6 mm <sup>2</sup> (AWG 8) 0.8...1 Nm
	VW3 A4 508, 509	10 mm <sup>2</sup> (AWG 6) 1.2...1.4 Nm	10 mm <sup>2</sup> (AWG 6) 1.2...1.4 Nm
	VW3 A4 510	10 mm <sup>2</sup> (AWG 6) 1.2...1.4 Nm	35 mm <sup>2</sup> (AWG 0) 2.5...3 Nm
	VW3 A4 511	–	Connected on a bar, Ø 9 –
	VW3 A4 512	–	Connected on a bar, Ø 9 –

References (1)					
For drives	Inductance value	Nominal current	Loss	Reference	Weight
	mH	A	W		kg
<b>Three-phase supply voltage: 200...240 V 50/60 Hz</b>					
ATV 61H075M3	6.8	8	22.5	<b>VW3 A4 503</b>	1.700
ATV 61HU15M3	3.2	14.3	32	<b>VW3 A4 505</b>	2.200
ATV 61HU22M3	2.2	19.2	33	<b>VW3 A4 506</b>	2.500
ATV 61HU30M3	1.6	27.4	43	<b>VW3 A4 507</b>	3.000
ATV 61HU40M3, HU55M3	1.2	44	61	<b>VW3 A4 508</b>	4.300
ATV 61HU75M3	0.7	36	30.5	<b>VW3 A4 509</b>	2.500
ATV 61HD11M3X, HD15M3X	0.52	84.5	77	<b>VW3 A4 510</b>	6.400
ATV 61HD18M3X, HD22M3X	0.22	171.2	86	<b>VW3 A4 511</b>	17.850
ATV 61HD30M3X... HD45M3X	0.09	195	73	<b>VW3 A4 512</b>	10.000
<b>Three-phase supply voltage: 380...480 V 50/60 Hz</b>					
ATV 61H075N4	18	2.25	7.7	<b>VW3 A4 501</b>	0.650
ATV 61HU15N4	10	4.3	11	<b>VW3 A4 502</b>	1.000
ATV 61HU22N4, HU30N4	6.8	8	22.5	<b>VW3 A4 503</b>	1.700
ATV 61HU40N4	3.9	10.7	27	<b>VW3 A4 504</b>	1.650
ATV 61HU55N4	3.2	14.3	32	<b>VW3 A4 505</b>	2.200
ATV 61HU75N4	2.2	19.2	33	<b>VW3 A4 506</b>	2.500
ATV 61HD11N4	1.6	27.4	43	<b>VW3 A4 507</b>	3.000
ATV 61HD15N4, HD18N4	1.2	44	57.5	<b>VW3 A4 508</b>	4.300
ATV 61HD22N4... HD37N4	0.52	84.5	98.3	<b>VW3 A4 510</b>	6.400
ATV 61HD45N4... HD75N4	0.22	171.2	128	<b>VW3 A4 511</b>	17.850

(1) For ATV 61HD55M3X...HD90M3X and ATV 61HD90N4...HC63N4 drives, the choke is supplied as standard with the drive.

It is integrated in ATV 61W●●●N4 and ATV 61W●●●N4C drives.



# Variable speed drives

## Altivar 61: reduction of current harmonics

### Option: line chokes

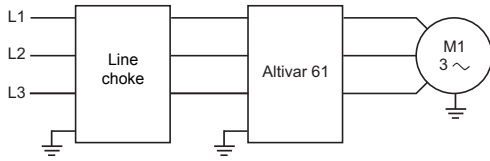

#### Line chokes

A line choke can be used to provide improved protection against overvoltages on the line supply and to reduce harmonic distortion of the current produced by the drive.

Line chokes are mandatory:

- For ATV 61HU40M3...HU75M3 drives powered by a 200...240 V 50/60 Hz single-phase supply voltage
- For ATV 61HC11Y...HC80Y drives

Line chokes can be used instead of a DC choke with ATV 61H●●●M3 drives powered by a 200...240V 50/60 Hz three-phase supply voltage, and ATV 61H●●●M3X and ATV 61●●●●N4 drives.

To obtain an ATV 61HD55M3X...HD90M3X or ATV 61HD90N4...HC63N4 drive without a DC choke, add the letter D at the end of the drive reference, see page 24.

The recommended chokes are used to limit the line current.

They have been developed in line with standard EN 50178 (VDE 0160 level 1 high energy overvoltages on the line supply).

The choke values are defined for a voltage drop between phases of between 3% and 5% of the nominal supply voltage. Values higher than this will cause loss of torque.

These chokes should be installed upstream of the drive.

#### Applications

The use of line chokes is recommended in particular under the following circumstances:

- Close connection of several drives in parallel
- Line supply with significant disturbance from other equipment (interference, overvoltages)
- Line supply with voltage imbalance between phases above 1.8% of the nominal voltage
- Drive supplied by a line with very low impedance (in the vicinity of power transformers 10 times more powerful than the drive rating)
- Installation of a large number of frequency inverters on the same line
- Reducing overloads on the  $\cos \varphi$  correction capacitors, if the installation includes a power factor correction unit

### Example of current harmonic levels for ATV 61H●●●Y drives (1)

Three-phase supply voltage: 500 V 50 Hz, with optional line choke																					
Motor power	For ATV 61 drives	Line supply		Current harmonic levels																THD (3)	
		Line current (2)	Line Isc (2)	H1	H5	H7	H11	H13	H17	H19	H23	H25	H29	H31	H35	H37	H41	H43	H47		H49
kW		A	kA	A	%	%	%	%	%	%	%	%	%	%	%	%	%	%	%	%	
2.2	HU30Y (4)	3.8	22	3.6	32.7	10.1	6.9	3.4	2.8	2	1.3	1.2	0.7	0.7	0.5	0.5	0.4	0.4	0.3	0.3	35.3
3	HU40Y (4)	5	22	4.8	29.3	8.4	6.1	3.4	2.2	1.9	1	1	0.7	0.6	0.5	0.4	0.4	0.3	0.3	0.2	31.47
4	HU55Y (4)	6.7	22	6.2	36.2	13	7.5	3.6	3.4	2.1	1.8	1.4	1	0.9	0.6	0.6	0.4	0.4	0.3	0.3	39.63
5.5	HU75Y (4)	8.9	22	8.4	32.3	10	6.9	3.5	2.9	2.1	1.4	1.3	0.8	0.7	0.5	0.5	0.4	0.4	0.3	0.3	34.93
7.5	HD11Y (4)	12	22	11.2	35.5	12.9	7.5	3.7	3.5	2.2	1.9	1.5	1.1	1	0.7	0.7	0.5	0.4	0.4	0.3	39.05
11	HD15Y (4)	16.9	22	16	31.1	9.6	6.9	3.6	2.9	2.1	1.4	1.3	0.8	0.7	0.5	0.5	0.4	0.4	0.3	0.3	33.76
15	HD18Y (4)	22.1	22	20.8	33.1	11.6	7.4	3.9	3.5	2.4	1.9	1.6	1.1	1.0	0.7	0.7	0.5	0.4	0.4	0.3	36.48
18.5	HD22Y (4)	27.1	22	25.7	30.8	9.9	7.2	3.9	3.3	2.3	1.7	1.4	0.9	0.9	0.6	0.5	0.4	0.4	0.4	0.3	33.72
22	HD30Y (4)	32	22	30.1	32.4	12.1	7.6	4.3	3.9	2.7	2.3	1.8	1.4	1.2	0.9	0.8	0.6	0.5	0.4	0.4	36.16
30	HD37Y (4)	43.9	22	41.2	34	11.5	7.5	3.7	3.5	2.3	1.9	1.5	1.1	1	0.7	0.7	0.5	0.4	0.4	0.3	36.97
37	HD45Y (4)	53.8	22	51	31.3	9.8	7.2	3.7	3.2	2.3	1.6	1.4	0.9	0.9	0.6	0.5	0.4	0.4	0.4	0.3	34.1
45	HD55Y (4)	64.1	22	60.4	32.2	10.9	7.5	3.9	3.6	2.4	2	1.6	1.2	1.1	0.7	0.7	0.5	0.5	0.4	0.3	35.42
55	HD75Y (4)	78.6	22	74.1	32.7	10.4	7.2	3.7	3.3	2.3	1.8	1.5	1	0.9	0.6	0.6	0.4	0.4	0.4	0.3	35.56
75	HD90Y (4)	106.5	22	101.5	29.4	8.5	6.7	3.7	2.9	2.2	1.4	1.2	0.7	0.7	0.5	0.4	0.4	0.4	0.3	0.3	31.83
90	HC11Y (5)	127.2	22	117.3	38.7	13.93	7.12	3.2	3.02	1.87	1.57	1.15	0.84	0.78	0.52	0.49	0.36	0.33	0.29	0.22	42.11
110	HC13Y (5)	153	28	142.9	35.5	11.18	6.68	3.17	2.67	1.83	1.24	1.14	0.69	0.69	0.47	0.42	0.36	0.29	0.27	0.23	38.17
132	HC16Y (5)	181.4	28	171.1	33.1	9.38	6.2	3.14	2.36	1.78	1.03	0.99	0.62	0.54	0.45	0.36	0.33	0.28	0.22	0.2	35.28
160	HC20Y (5)	218.1	35	207.2	42	16.92	7.22	3.54	3.23	1.82	1.72	1.17	1	0.83	0.58	0.58	0.41	0.38	0.27	0.27	46.24
200	HC25Y (5)	276.9	35	255.9	37.9	13.25	6.93	3.15	2.87	1.85	1.41	1.19	0.75	0.75	0.47	0.47	0.33	0.3	0.26	0.24	41.05
250	HC31Y (5)	341.7	35	320.4	34.7	10.26	6.42	3.07	2.52	1.79	1.17	1.04	0.64	0.6	0.44	0.35	0.33	0.26	0.24	0.2	37.05
315	HC40Y (5)	426	35	404	40.2	15.44	7.22	3.29	3.1	1.87	1.64	1.16	0.9	0.83	0.56	0.53	0.37	0.37	0.3	0.25	44.05
400	HC50Y (5)	546.7	35	509	34.6	10.56	6.59	3.14	2.6	1.83	1.18	1.12	0.65	0.65	0.4	0.4	0.36	0.29	0.25	0.24	37.14
500	HC63Y (5)	672.3	42	637.1	31.8	8.62	5.98	3.14	2.15	1.74	0.95	0.93	0.62	0.51	0.46	0.34	0.31	0.28	0.2	0.2	33.75
630	HC80Y (5)	846.4	42	807.5	29.7	7.77	5.44	3.18	1.81	1.62	0.88	0.8	0.62	0.49	0.42	0.39	0.27	0.27	0.2	0.18	31.47

### Three-phase supply voltage: 600 V 60 Hz, with optional line choke

Motor power	For ATV 61 drives	Line supply		Current harmonic levels																THD (3)	
		Line current (2)	Line Isc (2)	H1	H5	H7	H11	H13	H17	H19	H23	H25	H29	H31	H35	H37	H41	H43	H47		H49
HP		A	kA	A	%	%	%	%	%	%	%	%	%	%	%	%	%	%	%	%	
3	HU30Y (4)	3.2	22	3	34.9	11.8	7.3	3.5	3.1	2.1	1.6	1.3	0.9	0.8	0.6	0.5	0.4	0.4	0.3	0.3	38.03
-	HU40Y (4)	-	-	-	-	-	-	-	-	-	-	-	-	-	-	-	-	-	-	-	-
5	HU55Y (4)	5.6	22	5.2	38.6	15.3	7.8	3.9	3.6	2.1	2	1.5	1.2	1	0.7	0.7	0.5	0.5	0.4	0.4	42.79
7.5	HU75Y (4)	7.4	22	7	34.3	11.5	7.3	3.6	3.2	2.1	1.6	1.4	0.9	0.9	0.6	0.5	0.4	0.4	0.3	0.3	37.36
10	HD11Y (4)	10.1	22	9.3	37.7	15	7.8	3.9	3.7	2.2	2.1	1.5	1.2	1.1	0.8	0.8	0.5	0.5	0.4	0.4	41.81
15	HD15Y (4)	14.1	22	13.3	32.7	10.8	7.3	3.7	3.2	2.2	1.6	1.4	0.9	0.9	0.6	0.5	0.4	0.4	0.3	0.3	35.75
20	HD18Y (4)	18.5	22	17.3	34.6	13.1	7.7	4	3.8	2.4	2.1	1.7	1.3	1.1	0.8	0.8	0.5	0.5	0.4	0.4	38.44
25	HD22Y (4)	22.7	22	21.4	32.1	11	7.5	3.9	3.5	2.4	1.9	1.6	1.1	1	0.7	0.6	0.5	0.4	0.4	0.3	35.31
30	HD30Y (4)	26.7	22	25	33.4	13.3	7.9	4.4	4.1	2.7	2.4	1.9	1.5	1.3	1	0.9	0.7	0.6	0.5	0.4	37.61
40	HD37Y (4)	36.8	22	34.2	36	13.4	7.7	3.9	3.7	2.3	2.1	1.6	1.3	1.1	0.8	0.8	0.5	0.5	0.4	0.4	39.39
50	HD45Y (4)	45	22	42.3	32.9	11.1	7.5	3.8	3.5	2.3	1.9	1.5	1.1	1	0.7	0.6	0.5	0.4	0.4	0.3	36.07
60	HD55Y (4)	53.6	22	50.2	33.7	12.4	7.7	4	3.8	2.5	2.2	1.7	1.3	1.2	0.8	0.8	0.6	0.5	0.4	0.4	37.38
75	HD75Y (4)	65.7	22	61.5	34	11.9	7.5	3.8	3.6	2.3	2	1.6	1.2	1.1	0.7	0.7	0.5	0.4	0.4	0.3	37.39
100	HD90Y (4)	88.7	22	84.2	30.5	9.4	7.1	3.8	3.2	2.3	1.6	1.4	0.9	0.8	0.6	0.5	0.4	0.4	0.3	0.3	33.24
125	HC11Y (5)	112.4	22	103.1	39.6	14.95	7.34	3.5	3.16	1.85	1.65	1.23	0.89	0.82	0.53	0.53	0.34	0.35	0.26	0.23	43.31
150	HC13Y (5)	133	28	123.3	36.7	12.32	6.99	3.27	2.92	1.89	1.43	1.2	0.74	0.74	0.48	0.45	0.35	0.28	0.27	0.2	39.73
180	HC16Y (5)	158.9	28	149.3	34.1	10.23	6.58	3.17	2.61	1.85	1.18	1.09	0.66	0.62	0.46	0.37	0.35	0.27	0.25	0.2	36.5
200	HC20Y (5)	196.7	35	186.4	42.6	17.75	7.47	3.87	3.26	1.88	1.76	1.23	1.07	0.84	0.61	0.57	0.38	0.42	0.29	0.27	47.13
250	HC25Y (5)	249.2	35	230	38.5	13.82	7.17	3.35	3.08	1.85	1.57	1.2	0.86	0.8	0.52	0.49	0.34	0.31	0.28	0.22	41.91
350	HC31Y (5)	310.6	35	290.8	35	10.87	6.71	3.16	2.7	1.85	1.26	1.12	0.68	0.66	0.46	0.39	0.34	0.27	0.27	0.2	37.61
450	HC40Y (5)	389.8	35	369.2	40.8	15.83	7.34	3.56	3.25	1.76	1.7	1.14	0.93	0.79	0.56	0.54	0.37	0.33	0.25	0.23	44.78
550	HC50Y (5)	493.8	35	458.4	35.4	11.21	6.84	3.21	2.77	1.85	1.31	1.14	0.69	0.69	0.46	0.42	0.35	0.28	0.26	0.2	38.08
700	HC63Y (5)	612.5	42	577.4	33.1	9.68	6.44	3.2	2.45	1.84	1.08	1.05	0.61	0.6	0.45	0.37	0.34	0.27	0.23	0.21	35.42
800	HC80Y (5)	771.2	42	734.5	30.2	8.02	5.74	3.19	1.96	1.68	0.9	0.84	0.61	0.47	0.42	0.35	0.27	0.25	0.18	0.16	32.04

(1) Example of current harmonic levels up to harmonic order 49 for a 500 V 50 Hz or 600 V 60 Hz line supply for ATV 61H●●●Y drives, with line chokes.

(2) The line Isc values are given for the current harmonic levels stated in the table.

(3) Total harmonic distortion in accordance with IEC 61000-3-12.

(4) Use of a line choke is recommended.

(5) Use of a line choke is mandatory.

# Variable speed drives

## Altivar 61: reduction of current harmonics

Option: line chokes

### Example of current harmonic levels for ATV 61H●●●Y drives (1) (continued)

Three-phase supply voltage: 690 V 50 Hz, with optional line choke

Motor power	For ATV 61 drives	Line supply		Current harmonic levels																THD (3)	
		Line current	Line Isc (2)	H1	H5	H7	H11	H13	H17	H19	H23	H25	H29	H31	H35	H37	H41	H43	H47		H49
kW		A	kA	A	%	%	%	%	%	%	%	%	%	%	%	%	%	%	%	%	
3	HU30Y (4)	3.7	22	3.4	37.6	14	7.6	3.7	3.4	2.1	1.8	1.4	1	0.9	0.6	0.6	0.4	0.4	0.4	0.3	41.33
4	HU40Y (4)	4.8	22	4.5	33.8	10.9	7.1	3.5	3	2	1.4	1.3	0.8	0.8	0.5	0.5	0.4	0.4	0.3	0.3	36.65
5.5	HU55Y (4)	6.7	22	6.05	41.9	18.4	7.94	4.27	3.72	2.13	2.13	1.42	1.33	1.04	0.86	0.77	0.58	0.57	0.41	0.43	47.01
7.5	HU75Y (4)	8.7	22	8.1	37	13.8	7.6	3.7	3.4	2.1	1.8	1.4	1.1	1	0.6	0.7	0.4	0.4	0.4	0.3	40.67
11	HD11Y (4)	12.7	22	11.6	40	17	7.8	4.1	3.7	2.2	2.2	1.5	1.3	1.1	0.9	0.8	0.6	0.6	0.4	0.4	44.70
15	HD15Y (4)	16.6	22	15.5	35.4	12.8	7.5	3.7	3.5	2.2	1.9	1.5	1.1	1	0.7	0.7	0.5	0.4	0.4	0.3	38.89
18.5	HD18Y (4)	20.3	22	18.5	39.5	17.3	7.7	4.2	3.9	2.4	2.3	1.6	1.5	1.2	1	0.9	0.7	0.6	0.5	0.5	44.38
22	HD22Y (4)	23.8	22	22.1	36.6	14.6	7.6	4	3.8	2.4	2.2	1.6	1.4	1.1	0.9	0.8	0.6	0.6	0.4	0.4	40.74
30	HD30Y (4)	32.1	22	29.7	36.9	16	7.7	4.4	4.1	2.6	2.5	1.8	1.7	1.3	1.1	1	0.8	0.7	0.5	0.5	41.65
37	HD37Y (4)	40.3	22	36.7	40	17.4	7.8	4.2	3.8	2.3	2.3	1.6	1.5	1.1	1	0.9	0.7	0.6	0.5	0.5	44.97
45	HD45Y (4)	48.3	22	44.7	36.9	14.2	7.7	3.9	3.7	2.3	2.1	1.6	1.3	1.1	0.8	0.8	0.5	0.5	0.4	0.4	40.81
55	HD55Y (4)	58	22	53.4	38.1	15.9	7.7	4.1	3.9	2.4	2.4	1.7	1.5	1.2	1	0.9	0.7	0.7	0.5	0.5	42.62
75	HD75Y (4)	78.8	22	73	36.8	13.9	7.5	3.8	3.6	2.2	2.1	1.5	1.3	1.1	0.8	0.8	0.5	0.5	0.4	0.4	40.58
90	HD90Y (4)	93.7	22	87.7	34.3	11.6	7.3	3.7	3.5	2.3	1.9	1.5	1.1	1	0.7	0.7	0.5	0.4	0.4	0.3	37.45
110	HC11Y (5)	116.8	28	103.4	46.8	21.75	7.52	4.45	3.35	2.05	1.92	1.16	1.16	0.89	0.75	0.6	0.49	0.46	0.33	0.32	52.56
132	HC13Y (5)	136.9	28	123.5	42.2	17.31	7.37	3.66	3.26	1.89	1.77	1.2	1.03	0.86	0.63	0.57	0.4	0.41	0.27	0.27	49.61
160	HC16Y (5)	162.8	35	149.4	39.7	14.86	7.24	3.31	3.08	1.89	1.61	1.18	0.85	0.85	0.52	0.52	0.35	0.35	0.28	0.24	43.32
200	HC20Y (5)	199.1	35	185.5	49	23.99	7.56	4.85	3.36	2.14	1.99	1.15	1.22	0.84	0.8	0.57	0.53	0.46	0.38	0.34	55.52
250	HC25Y (5)	256.5	35	230.2	43.9	18.86	7.4	3.9	3.32	1.9	1.81	1.17	1.11	0.86	0.68	0.61	0.43	0.46	0.3	0.31	48.72
315	HC31Y (5)	316.9	35	290.8	39.7	14.86	7.2	3.28	3.11	1.9	1.63	1.19	0.9	0.85	0.56	0.56	0.39	0.39	0.29	0.27	43.34
400	HC40Y (5)	393.8	35	367.5	45	20.1	7.56	4.26	3.37	1.97	1.93	1.24	1.16	0.89	0.75	0.68	0.5	0.48	0.35	0.39	50.31
500	HC50Y (5)	504.2	35	460.4	39.3	14.21	7.24	3.27	3.14	1.84	1.58	1.17	0.86	0.79	0.53	0.49	0.36	0.32	0.26	0.22	42.73
630	HC63Y (5)	615.9	42	572.2	37	12.12	7.01	3.15	2.94	1.82	1.43	1.16	0.77	0.73	0.49	0.44	0.37	0.28	0.3	0.22	39.87
800	HC80Y (5)	775	42	730.2	33.4	9.63	6.36	3.14	2.43	1.82	1.08	1.05	0.63	0.59	0.46	0.37	0.35	0.28	0.24	0.22	35.63

(1) Example of current harmonic levels up to harmonic order 49 for a 690 V 50 Hz line supply for ATV 61H●●●Y drives, with line chokes.

(2) The line Isc values are given for the current harmonic levels stated in the table.

(3) Total harmonic distortion in accordance with IEC 61000-3-12.

(4) Use of a line choke is recommended.

(5) Use of a line choke is mandatory.

General characteristics		VW3 A58501, A58502	VW3 A4 551... A4 553	VW3 A4 554, A4 555	VW3 A4 556... A4 560	VW3 A4 561, A4 564, 565, A4 568...572
Type of choke						
Conforming to standards		EN 50178 (VDE 0160 level 1 high energy overvoltages on the line supply), IEC 60076 (with HD 398)				
Degree of protection	Choke	IP 00				
	Terminals	IP 20		IP 10	IP 00	
Atmospheric pollution		3 C2, 3B1, 3S1 conforming to IEC 721.3.3				
Degree of pollution		2 conforming to EN 50178				
Vibration resistance		1.5 mm from 3...13 Hz, 1 gn from 13...200 Hz, conforming to IEC 60068-2				
Shock resistance		15 gn for 11 ms conforming to IEC 60068-2-27				
Maximum relative humidity		95%				
Ambient air temperature around the device	Operation	°C 0... + 45 without derating Up to + 55°C with current derating of 2% per °C above 45°C				
	Storage	°C - 25...+ 70				
Insulation class		F				
Clearance distance in air		mm 5.5 conforming to IEC 60664				
Leakage distance in air		mm 11.5 conforming to IEC 60664				
Maximum operating altitude		m 1000 without derating 1000...3000 with current derating of 1% per additional 100 m				
Voltage drop		Between 3% and 5% of the nominal supply voltage. Values higher than this will cause loss of torque.				
Maximum current		1.65 x nominal current for 60 seconds				

Connection characteristics			
Maximum wire size and tightening torque	VW3 A58501	16 mm <sup>2</sup> , (AWG 4)	1.2...1.4 Nm
	VW3 A58502	6 mm <sup>2</sup> , (AWG 8)	0.8...1 Nm
	VW3 A4 551, 552	2.5 mm <sup>2</sup> , (AWG 12)	0.4...0.6 Nm
	VW3 A4 553	6 mm <sup>2</sup> , (AWG 8)	0.8...1 Nm
	VW3 A4 554	16 mm <sup>2</sup> , (AWG 4)	1.2...1.4 Nm
	VW3 A4 555	35 mm <sup>2</sup> , (AWG 0)	2.5...3 Nm
	VW3 A4 556	Connected on a bar, Ø 6.5 mm	–
	VW3 A4 557, 558, 570	Connected on a bar, Ø 9 mm	–
	VW3 A4 559...561, 568	Connected on a bar, Ø 11 mm	–
	VW3 A4 564, 565, 569, 571, 572	Connected on a bar, Ø 13 mm	–

References								
For drives	Line supply		Line choke			Quantity per drive	Reference	Weight
	Line	Isc	Induc-tance value	Nominal current	Saturation current			
	kA		mH	A	A	W		kg
<b>Single-phase supply voltage: 200...240 V 50/60 Hz</b>								
ATV 61HU40M3 (1)	5	2	25	–	45	1	VW3 A58501	3.500
ATV 61HU55M3 (1)	5	1	45	–	50	1	VW3 A58502	3.500
ATV 61HU75M3 (1)	22	1	45	–	50	1	VW3 A58502	3.500
<b>Three-phase supply voltage: 200...240 V 50/60 Hz</b>								
ATV 61H075M3	5	10	4	–	45	1	VW3 A4 551	1.500
ATV 61HU15M3, HU22M3	5	4	10	–	65	1	VW3 A4 552	3.000
ATV 61HU30M3	5	2	16	–	75	1	VW3 A4 553	3.500
ATV 61HU40M3	5	1	30	–	90	1	VW3 A4 554	6.000
ATV 61HU55M3	22	1	30	–	90	1	VW3 A4 554	6.000
ATV 61HU75M3, HD11M3X	22	0.5	60	–	94	1	VW3 A4 555	11.000
ATV 61HD15M3X	22	0.3	100	–	260	1	VW3 A4 556	16.000
ATV 61HD18M3X...HD45M3X	22	0.15	230	–	400	1	VW3 A4 557	45.000
ATV 61HD55M3XD	35	0.12	222	346	278	1	VW3 A4 559	35.000
ATV 61HD75M3XD	35	0.085	300	474	315	1	VW3 A4 568	46.000
ATV 61HD90M3XD	35	0.06	450	574	335	1	VW3 A4 569	70.000

(1) Use of a line choke is mandatory, to be ordered separately.

# Variable speed drives

## Altivar 61: reduction of current harmonics

### Option: line chokes

PF107532



VW3 A4 572

References								
For drives	Line supply Line Isc	Line choke				Quantity per drive	Reference	Weight
		Inductance value	Nominal current	Saturation current	Loss			
	kA	mH	A	A	W			kg
<b>Three-phase supply voltage: 380...480 V 50/60 Hz</b>								
ATV 61H075N4, HU15N4 ATV 61W075N4, WU15N4 ATV 61W075N4C, WU15N4C	5	10	4	–	45	1	VW3 A4 551	1.500
ATV 61HU22N4...HU40N4 ATV 61WU22N4...WU40N4 ATV 61WU22N4C...WU40N4C	5	4	10	–	65	1	VW3 A4 552	3.000
ATV 61HU55N4, HU75N4 ATV 61WU55N4, WU75N4 ATV 61WU55N4C, WU75N4C	22	2	16	–	75	1	VW3 A4 553	3.500
ATV 61HD11N4, HD15N4 ATV 61WD11N4, WD15N4 ATV 61WD11N4C, WD15N4C	22	1	30	–	90	1	VW3 A4 554	6.000
ATV 61HD18N4, HD22N4 ATV 61WD18N4, WD22N4 ATV 61WD18N4C, WD22N4C	22	0.5	60	–	94	1	VW3 A4 555	11.000
ATV 61HD30N4...HD55N4 ATV 61WD30N4...WD55N4 ATV 61WD30N4C...WD55N4C	22	0.3	100	–	260	1	VW3 A4 556	16.000
ATV 61HD75N4 ATV 61WD75N4 ATV 61WD75N4C	22	0.15	230	–	400	1	VW3 A4 557	45.000
ATV 61HD90N4D ATV 61WD90N4 ATV 61WD90N4C	35	0.155	184	370	220	1	VW3 A4 558	31.000
ATV 61HC11N4D	35	0.12	222	346	278	1	VW3 A4 559	35.000
ATV 61HC13N4D	35	0.098	264	530	245	1	VW3 A4 560	43.000
ATV 61HC16N4D	50	0.085	300	474	315	1	VW3 A4 568	46.000
ATV 61HC22N4D	Motor P 200 kW	0.066	344	685	258	1	VW3 A4 561	47.000
	Motor P 220 kW	0.06	450	574	335	1	VW3 A4 569	70.000
ATV 61HC25N4D	50	0.06	450	574	335	1	VW3 A4 569	70.000
ATV 61HC31N4D	50	0.038	613	1150	307	1	VW3 A4 564	73.000
ATV 61HC40N4D	50	0.032	720	1352	428	1	VW3 A4 565	82.000
ATV 61HC50N4D	50	0.06	450	574	335	2	VW3 A4 569	70.000
ATV 61HC63N4D	50	0.038	613	1150	307	2	VW3 A4 564	73.000
<b>Three-phase supply voltage: 500...690 V 50/60 Hz</b>								
ATV 61HU30Y...HU55Y (1)	22	10	4	–	45	1	VW3 A4 551	1.500
ATV 61HU75Y, HD11Y (1)	22	4	10	–	65	1	VW3 A4 552	3.000
ATV 61HD15Y, HD18Y (1)	22	2	16	–	75	1	VW3 A4 553	3.500
ATV 61HD22Y, HD30Y (1)	22	1	30	–	90	1	VW3 A4 554	6.000
ATV 61HD37Y...HD55Y (1)	22	0.5	60	–	94	1	VW3 A4 555	11.000
ATV 61HD75Y, HD90Y (1)	22	0.3	100	–	260	1	VW3 A4 556	16.000
ATV 61HC11Y (2)	28	0.22	160	320	220	1	VW3 A4 570	28.000
ATV 61HC13Y (2)	28	0.22	160	320	220	1	VW3 A4 570	28.000
ATV 61HC16Y (2)	28	0.23	230	405	330	1	VW3 A4 571	79.000
ATV 61HC20Y (2)	35	0.23	230	405	330	1	VW3 A4 571	79.000
ATV 61HC25Y (2)	35	0.098	264	530	245	1	VW3 A4 560	35.000
ATV 61HC31Y, HC40Y (2)	35	0.1	450	770	495	1	VW3 A4 572	90.000
ATV 61HC50Y (2)	35	0.085	300	474	315	2	VW3 A4 568	46.000
ATV 61HC63Y (2)	35	0.1	450	770	495	2	VW3 A4 572	90.000
ATV 61HC80Y (2)	42	0.1	450	770	495	2	VW3 A4 572	90.000

(1) Use of a line choke is recommended, to be ordered separately.

(2) Use of a line choke is mandatory, to be ordered separately.

### Passive filters

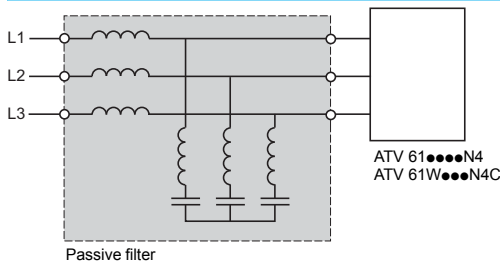

A passive filter is used to reduce current harmonics with total harmonic distortion factors of less than 16% or 10%. These ratios may be less than 10% or 5% if the filter is used with a DC choke, see pages 146 to 149.

The reactive power increases at no load or low load. To eliminate this reactive power, the filter capacitors can be disconnected via the drive, see page 219.

To do this, the contactor must be controlled by one of the relay outputs on the drive, at a value lower than 10% of the nominal drive current ( $I_n$ ) (please refer to the Programming Manual).

For ATV 61H...Y drives, use of a line choke is recommended or mandatory, depending on the rating.

### Applications

Reduction of current harmonics in order to use drives in the first environment.

### General characteristics

Degree of protection		IP 20
Maximum relative humidity		Class F humidity without condensation 5%...85%
Ambient air temperature around the device	Operation	°C 5...+ 40 without derating Up to 55°C with current derating of 3% per additional °C
	Storage	°C - 25...+ 55
Maximum operating altitude	m	1000 without derating 1000...4000 derating the current by 5% per additional 1000 m

### Electrical characteristics

Range	400 V	460 V
Nominal voltage $\pm 10\%$	V 380...415 ~	440... 480 ~
Operating frequency	50 $\pm 5\%$	60 $\pm 5\%$
Overload capacity	1.5 x $I_n$ (A)	
Efficiency	98% (2% thermal losses)	
THDI (1)	%	
Cos $\varphi$	At 75% of the line current: 0.85 At 100% of the line current: 0.99 At 150% of the line current: 1	

### Connection characteristics

Maximum wire size	Wire size	Connection
VW3 A4 601...604	16 mm <sup>2</sup>	
VW3 A4 605...609	50 mm <sup>2</sup>	
VW3 A4 610, 611		Connected on a bar, Ø 12.5
VW3 A4 612, 613, 619		Connected on a bar, Ø 16.5
VW3 A4 618		Connected on a bar, Ø 16.5
VW3 A4 621, 622	16 mm <sup>2</sup>	
VW3 A4 623...627	50 mm <sup>2</sup>	
VW3 A4 628, 629		Connected on a bar, Ø 12.5
VW3 A4 630...639		Connected on a bar, Ø 16.5
VW3 A4 641...644	16 mm <sup>2</sup>	
VW3 A4 645...648	50 mm <sup>2</sup>	
VW3 A4 649		Connected on a bar, Ø 12.5
VW3 A4 650, 651, 656, 657		Connected on a bar, Ø 16.5
VW3 A4 661...663	16 mm <sup>2</sup>	
VW3 A4 664...666	50 mm <sup>2</sup>	
VW3 A4 667, 668		Connected on a bar, Ø 12.5
VW3 A4 669, 671, 676, 677		Connected on a bar, Ø 16.5

(1) The total current harmonic distortion (THDI) is indicated for a total voltage harmonic distortion (THDU) < 2% and a short-circuit ratio (RSCE) > 66%, and only for the nominal current of the passive filter. If these conditions are not adhered to, the total current harmonics will be reduced without any guarantee of level.

## Variable speed drives

Altivar 61: reduction of current harmonics

Option: passive filters

Passive filters: Three-phase power supply 400 V 50 Hz							
Motor rating		For ATV 61 drives	Line supply	Filter	Quantity per drive	Reference	Weight
kW	HP		Line current	In (2)			kg
<b>THDI 16% (1)</b>							
0.75	1	H075N4	2.5	6	1	VW3 A4 601	15.000
1.5	2	HU15N4	3.6	6	1	VW3 A4 601	15.000
2.2	3	HU22N4	5	6	1	VW3 A4 601	15.000
3	–	HU30N4	6	6	1	VW3 A4 601	15.000
4	5	HU40N4	7.8	10	1	VW3 A4 602	19.000
5.5	7.5	HU55N4	10	10	1	VW3 A4 602	19.000
7.5	10	HU75N4	14	19	1	VW3 A4 603	21.000
11	15	HD11N4	19	19	1	VW3 A4 603	21.000
15	20	HD15N4	26	26	1	VW3 A4 604	22.000
18.5	25	HD18N4	32	35	1	VW3 A4 605	34.000
22	30	HD22N4	38	43	1	VW3 A4 606	38.000
30	40	HD30N4	52	72	1	VW3 A4 607	56.000
37	50	HD37N4	63	72	1	VW3 A4 607	56.000
45	60	HD45N4	77	101	1	VW3 A4 608	69.000
55	75	HD55N4	91	101	1	VW3 A4 608	69.000
75	100	HD75N4	126	144	1	VW3 A4 609	97.000
<b>THDI 10%</b>							
0.75	1	W075N4, W075N4C	2.5	6	1	VW3 A4 601	15.000
1.5	2	WU15N4, WU15N4C	3.6	6	1	VW3 A4 601	15.000
2.2	3	WU22N4, WU22N4C	5	6	1	VW3 A4 601	15.000
3	–	WU30N4, WU30N4C	6	6	1	VW3 A4 601	15.000
4	5	WU40N4, WU40N4C	7.8	10	1	VW3 A4 602	19.000
5.5	7.5	WU55N4, WU55N4C	10	10	1	VW3 A4 602	19.000
7.5	10	WU75N4, WU75N4C	14	19	1	VW3 A4 603	21.000
11	15	WD11N4, WD11N4C	19	19	1	VW3 A4 603	21.000
15	20	WD15N4, WD15N4C	26	26	1	VW3 A4 604	22.000
18.5	25	WD18N4, WD18N4C	32	35	1	VW3 A4 605	34.000
22	30	WD22N4, WD22N4C	38	43	1	VW3 A4 606	38.000
30	40	WD30N4, WD30N4C	52	72	1	VW3 A4 607	56.000
37	50	WD37N4, WD37N4C	63	72	1	VW3 A4 607	56.000
45	60	WD45N4, WD45N4C	77	101	1	VW3 A4 608	69.000
55	75	WD55N4, WD55N4C	91	101	1	VW3 A4 608	69.000
75	100	WD75N4, WD75N4C	126	144	1	VW3 A4 609	97.000
90	125	HD90N4, WD90N4, WD90N4C	149	144	1	VW3 A4 609	97.000
110	150	HC11N4	182	180	1	VW3 A4 610	103.000
132	200	HC13N4	218	216	1	VW3 A4 611	112.000
160	250	HC16N4	287	289	1	VW3 A4 612	135.000
200	300	HC22N4	353.5	370	1	VW3 A4 613	155.000
220	350	HC22N4	364	370	1	VW3 A4 613	155.000
250	400	HC25N4	415	216	2	VW3 A4 611	112.000
280	450	HC31N4	485	289	2	VW3 A4 612	135.000
315	500	HC31N4	543	289	2	VW3 A4 612	135.000
355	–	HC40N4	588	289	2	VW3 A4 612	135.000
400	600	HC40N4	664	325	2	VW3 A4 619	155.000
500	700	HC50N4	840	289	3	VW3 A4 612	135.000
560	800	HC63N4	978	370	3	VW3 A4 613	155.000
630	900	HC63N4	1091	370	3	VW3 A4 613	155.000

(1) By adding a DC choke (see page 146) to ATV 61H075N4...HD75N4 drives, a THD  $\leq$  10% is obtained. These reduced current harmonics are obtained on condition that the THDU is  $<$  2%, the RSCE is  $>$  66%, and only for the nominal current of the passive filter.

(2) In: nominal filter current.

## Variable speed drives

Altivar 61: reduction of current harmonics

Option: passive filters

Passive filters: Three-phase power supply 400 V 50 Hz (continued)							
Motor rating		For ATV 61 drives	Line supply	Filter	Quantity per drive	Reference	Weight
kW	HP		Line current	In (2)			kg
<b>THDI 10% (1)</b>							
0.75	1	H075N4	2.5	6	1	VW3 A4 621	21.000
1.5	2	HU15N4	3.6	6	1	VW3 A4 621	21.000
2.2	3	HU22N4	5	6	1	VW3 A4 621	21.000
3	–	HU30N4	6	6	1	VW3 A4 621	21.000
4	5	HU40N4	7.8	10	1	VW3 A4 622	27.000
5.5	7.5	HU55N4	10	10	1	VW3 A4 622	27.000
7.5	10	HU75N4	14	19	1	VW3 A4 623	28.000
11	15	HD11N4	19	19	1	VW3 A4 623	28.000
15	20	HD15N4	26	26	1	VW3 A4 624	40.000
18.5	25	HD18N4	32	35	1	VW3 A4 625	49.000
22	30	HD22N4	38	43	1	VW3 A4 626	52.000
30	40	HD30N4	52	72	1	VW3 A4 627	88.000
37	50	HD37N4	63	72	1	VW3 A4 627	88.000
45	60	HD45N4	77	101	1	VW3 A4 628	150.000
55	75	HD55N4	91	101	1	VW3 A4 628	150.000
75	100	HD75N4	126	144	1	VW3 A4 629	167.000
<b>THDI 5% (1)</b>							
0.75	1	W075N4, W075N4C	2.5	6	1	VW3 A4 621	21.000
1.5	2	WU15N4, WU15N4C	3.6	6	1	VW3 A4 621	21.000
2.2	3	WU22N4, WU22N4C	5	6	1	VW3 A4 621	21.000
3	–	WU30N4, WU30N4C	6	6	1	VW3 A4 621	21.000
4	5	WU40N4, WU40N4C	7.8	10	1	VW3 A4 622	27.000
5.5	7.5	WU55N4, WU55N4C	10	10	1	VW3 A4 622	27.000
7.5	10	WU75N4, WU75N4C	14	19	1	VW3 A4 623	28.000
11	15	WD11N4, WD11N4C	19	19	1	VW3 A4 623	28.000
15	20	WD15N4, WD15N4C	26	26	1	VW3 A4 624	40.000
18.5	25	WD18N4, WD18N4C	32	35	1	VW3 A4 625	49.000
22	30	WD22N4, WD22N4C	38	43	1	VW3 A4 626	52.000
30	40	WD30N4, WD30N4C	52	72	1	VW3 A4 627	88.000
37	50	WD37N4, WD37N4C	63	72	1	VW3 A4 627	88.000
45	60	WD45N4, WD45N4C	77	101	1	VW3 A4 628	150.000
55	75	WD55N4, WD55N4C	91	101	1	VW3 A4 628	150.000
75	100	WD75N4, WD75N4C	126	144	1	VW3 A4 629	167.000
90	125	HD90N4 WD90N4, WD90N4C	149	144	1	VW3 A4 629	167.000
110	150	HC11N4	182	180	1	VW3 A4 630	178.000
132	200	HC13N4	218	216	1	VW3 A4 631	224.000
160	250	HC16N4	287	289	1	VW3 A4 632	271.000
200	300	HC22N4	353.5	370	1	VW3 A4 633	320.000
220	350	HC22N4	364	370	1	VW3 A4 633	320.000
250	400	HC25N4	415	216	2	VW3 A4 631	224.000
280	450	HC31N4	485	289	2	VW3 A4 632	271.000
315	500	HC31N4	543	289	2	VW3 A4 632	271.000
355	–	HC40N4	588	289	2	VW3 A4 632	271.000
400	600	HC40N4	664	325	2	VW3 A4 639	284.000
500	700	HC50N4	840	289	3	VW3 A4 632	271.000
560	800	HC63N4	918	370	3	VW3 A4 633	320.000
630	900	HC63N4	1091	370	3	VW3 A4 633	320.000

(1) By adding a DC choke (see page 146) to ATV 61H075N4...HD75N4 drives, a THD  $\leq$  5% is obtained. These reduced current harmonics are obtained on condition that the THDU is  $<$  2%, the RSCE  $>$  66%, and only for the nominal current of the passive filter.

(2) In: nominal filter current.



## Variable speed drives

Altivar 61: reduction of current harmonics

Option: passive filters

Passive filters: Three-phase power supply 460 V 60 Hz							
Motor rating		For ATV 61 drives	Line supply	Filter	Quantity per drive	Reference	Weight
kW	HP		Line current	In (2)			kg
<b>THDI 16% (1)</b>							
0.75	1	H075N4	2.5	6	1	VW3 A4 641	15.000
1.5	2	HU15N4	3	6	1	VW3 A4 641	15.000
2.2	3	HU22N4	5	6	1	VW3 A4 641	15.000
3	–	HU30N4	6	6	1	VW3 A4 641	15.000
4	5	HU40N4	7	10	1	VW3 A4 642	19.000
5.5	7.5	HU55N4	10	10	1	VW3 A4 642	19.000
7.5	10	HU75N4	13	19	1	VW3 A4 643	23.000
11	15	HD11N4	19	19	1	VW3 A4 643	23.000
15	20	HD15N4	24	26	1	VW3 A4 644	34.000
18.5	25	HD18N4	32	35	1	VW3 A4 645	42.000
22	30	HD22N4	35	35	1	VW3 A4 645	42.000
30	40	HD30N4	46	43	1	VW3 A4 646	45.000
37	50	HD37N4	58.7	72	1	VW3 A4 647	61.000
45	60	HD45N4	68	72	1	VW3 A4 647	61.000
55	75	HD55N4	82.6	101	1	VW3 A4 648	75.000
75	100	HD75N4	108	101	1	VW3 A4 648	75.000
<b>THDI 10% (1)</b>							
0.75	1	W075N4, W075N4C	2.5	6	1	VW3 A4 641	15.000
1.5	2	WU15N4, WU15N4C	3	6	1	VW3 A4 641	15.000
2.2	3	WU22N4, WU22N4C	5	6	1	VW3 A4 641	15.000
3	–	WU30N4, WU30N4C	6	6	1	VW3 A4 641	15.000
4	5	WU40N4, WU40N4C	7	10	1	VW3 A4 642	19.000
5.5	7.5	WU55N4, WU55N4C	10	10	1	VW3 A4 642	19.000
7.5	10	WU75N4, WU75N4C	13	19	1	VW3 A4 643	23.000
11	15	WD11N4, WD11N4C	19	19	1	VW3 A4 643	23.000
15	20	WD15N4, WD15N4C	24	26	1	VW3 A4 644	34.000
18.5	25	WD18N4, WD18N4C	32	35	1	VW3 A4 645	42.000
22	30	WD22N4, WD22N4C	35	35	1	VW3 A4 645	42.000
30	40	WD30N4, WD30N4C	46	43	1	VW3 A4 646	45.000
37	50	WD37N4, WD37N4C	58.7	72	1	VW3 A4 647	61.000
45	60	WD45N4, WD45N4C	68	72	1	VW3 A4 647	61.000
55	75	WD55N4, WD55N4C	82.6	101	1	VW3 A4 648	75.000
75	100	WD75N4, WD75N4C	108	101	1	VW3 A4 648	75.000
90	125	HD90N4 WD90N4, WD90N4C	134	180	1	VW3 A4 649	107.000
110	150	HC11N4	163	180	1	VW3 A4 649	107.000
132	200	HC13N4	192	217	1	VW3 A4 656	119.000
160	250	HC16N4	235	289	1	VW3 A4 650	145.000
200	300	HC22N4	300	370	1	VW3 A4 651	185.000
220	350	HC22N4	330	370	1	VW3 A4 651	185.000
250	400	HC25N4	400	217	2	VW3 A4 656	119.000
280	450	HC31N4	440	289	2	VW3 A4 650	145.000
315	500	HC31N4	470	289	2	VW3 A4 650	145.000
355	–	HC40N4	530	289	2	VW3 A4 650	145.000
400	600	HC40N4	590	325	2	VW3 A4 657	165.000
500	700	HC50N4	730	370	2	VW3 A4 651	185.000
560	800	HC63N4	858	325	3	VW3 A4 657	165.000
630	900	HC63N4	964	325	3	VW3 A4 657	165.000

(1) By adding a DC choke (see page 146) to ATV 61H075N4...HD75N4 drives, a THD ≤ 10% is obtained. These reduced current harmonics are obtained on condition that the THDU is < 2%, the RSCE is > 66%, and only for the nominal current of the passive filter.

(2) In: nominal filter current.

# Variable speed drives

## Altivar 61: reduction of current harmonics

### Option: passive filters

Passive filters: Three-phase power supply 460 V 60 Hz							
Motor rating		For ATV 61 drives	Line supply	Filter	Quantity per drive	Reference	Weight
kW	HP		Line current	In (2)			kg
<b>THDI 10% (1)</b>							
0.75	1	H075N4	2.5	6	1	VW3 A4 661	21.000
1.5	2	HU15N4	3	6	1	VW3 A4 661	21.000
2.2	3	HU22N4	5	6	1	VW3 A4 661	21.000
3	–	HU30N4	6	6	1	VW3 A4 661	21.000
4	5	HU40N4	7	10	1	VW3 A4 662	27.000
5.5	7.5	HU55N4	10	10	1	VW3 A4 662	27.000
7.5	10	HU75N4	13	19	1	VW3 A4 663	28.000
11	15	HD11N4	19	19	1	VW3 A4 663	28.000
15	20	HD15N4	24	26	1	VW3 A4 664	41.000
18.5	25	HD18N4	32	35	1	VW3 A4 665	49.000
22	30	HD22N4	35	35	1	VW3 A4 665	49.000
30	40	HD30N4	44	43	1	VW3 A4 666	56.000
37	50	HD37N4	58.7	72	1	VW3 A4 667	80.000
45	60	HD45N4	68	72	1	VW3 A4 668	98.000
55	75	HD55N4	82.6	101	1	VW3 A4 668	98.000
75	100	HD75N4	108	101	1	VW3 A4 668	98.000
<b>THDI 5% (1)</b>							
0.75	1	W075N4, W075N4C	2.5	6	1	VW3 A4 661	21.000
1.5	2	WU15N4, WU15N4C	3	6	1	VW3 A4 661	21.000
2.2	3	WU22N4, WU22N4C	5	6	1	VW3 A4 661	21.000
3	–	WU30N4, WU30N4C	6	6	1	VW3 A4 661	21.000
4	5	WU40N4, WU40N4C	7	10	1	VW3 A4 662	27.000
5.5	7.5	WU55N4, WU55N4C	10	10	1	VW3 A4 662	27.000
7.5	10	WU75N4, WU75N4C	13	19	1	VW3 A4 663	28.000
11	15	WD11N4, WD11N4C	19	19	1	VW3 A4 663	28.000
15	20	WD15N4, WD15N4C	24	26	1	VW3 A4 664	41.000
18.5	25	WD18N4, WD18N4C	32	35	1	VW3 A4 665	49.000
22	30	WD22N4, WD22N4C	35	35	1	VW3 A4 665	49.000
30	40	WD30N4, WD30N4C	44	43	1	VW3 A4 666	56.000
37	50	WD37N4, WD37N4C	58.7	72	1	VW3 A4 667	80.000
45	60	WD45N4, WD45N4C	68	72	1	VW3 A4 668	98.000
55	75	WD55N4, WD55N4C	82.6	101	1	VW3 A4 668	98.000
75	100	WD75N4, WD75N4C	108	101	1	VW3 A4 668	98.000
90	125	HD90N4 WD90N4, WD90N4C	134	180	1	VW3 A4 669	151.000
110	150	HC11N4	163	180	1	VW3 A4 669	151.000
132	200	HC13N4	192	217	1	VW3 A4 676	171.000
160	250	HC16N4	235	289	1	VW3 A4 670	215.000
200	300	HC22N4	300.5	370	1	VW3 A4 671	250.000
220	350	HC22N4	330	370	1	VW3 A4 671	250.000
250	400	HC25N4	400	217	2	VW3 A4 676	171.000
280	450	HC31N4	440	289	2	VW3 A4 670	240.000
315	500	HC31N4	470	289	2	VW3 A4 670	240.000
355	–	HC40N4	530	289	2	VW3 A4 670	240.000
400	600	HC40N4	590	325	2	VW3 A4 677	215.000
500	700	HC50N4	730	370	2	VW3 A4 671	250.000
560	800	HC63N4	858	325	3	VW3 A4 677	240.000
630	900	HC63N4	964	325	3	VW3 A4 677	240.000

(1) By adding a DC choke (see page 146) to ATV 61H075N4...HD75N4 drives, a THD ≤ 5% is obtained. These reduced current harmonics are obtained on condition that the THDU is < 2%, the RSCE is > 66%, and only for the nominal current of the passive filter.

(2) In: nominal filter current.

# Variable speed drives

## Altivar 61: EMC filters

### Integrated filters and optional additional filters

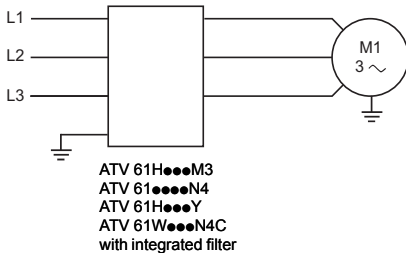

#### Integrated EMC filters

Altivar 61 drives, except for the ATV 61H●●●M3X, have built-in radio interference input filters to meet the EMC standard for variable speed electrical power drive “products” IEC/EN 61800-3, edition 2, category C2 or C3 in environment 1 or 2 and to comply with the European directive on EMC (electromagnetic compatibility).

#### UL Type 1/IP 20 drives

Drives	Maximum length of shielded cable (1) according to			
	EN 55011 (2) class A Gr1		EN 55011 (2) class A Gr2	
	IEC/EN 61800-3 category C2 (2)		IEC/EN 61800-3 category C3 (2)	
	LF (3) (4)	HF (3) (4)	LF (3) (4)	HF (3) (4)
	m	m	m	m
ATV 61H075M3...HU22M3	10	5	–	–
ATV 61HU30M3...HU75M3	–	–	10	5
ATV 61H075N4...HU40N4	10	5	–	–
ATV 61HU55N4...HD15N4	–	–	10	5
ATV 61HD18N4...HC63N4	–	–	50	25
ATV 61HU30Y...HD90Y	–	–	25	25
ATV 61HC11Y...HC80Y	–	–	50	25

#### UL Type 12/IP 54 drives

Drives	Maximum length of shielded cable (1) according to					
	EN 55011 (2) class A Gr1			EN 55011 (2) class B Gr1 (2)		
	IEC/EN 61800-3 category C2 (2)			IEC/EN 61800-3 category C1 (2)		
	LF (3)	HF (3)	16 kHz	LF (3)	HF (3)	16 kHz
	2 kHz	8 kHz	16 kHz	2 kHz	8 kHz	16 kHz
	m	m	m	m	m	m
ATV 61W●●●N4	80	50	50	–	–	–
ATV 61W075N4C...WU40N4C	–	–	–	20	20	20
ATV 61WU40N4C, WU55N4C	–	–	–	50	50	50
ATV 61WU75N4C, WD11N4C	–	–	–	20	20	20
ATV 61WD15N4C	–	–	–	50	50	50
ATV 61WD38N4C, WD22N4C	–	–	–	50	50	50
ATV 61WD30N4C	–	–	–	20	50	20
ATV 61WD37N4C, WD45N4C	–	–	–	20	50	20
ATV 61WD55N4C...WD90N4C	–	–	–	20	20	20

#### Additional EMC input filters

##### Applications

When used with ATV 61H●●●M3, H●●●M3X and ATV 61H●●●N4 drives, additional EMC input filters can be used to meet more stringent requirements and are designed to reduce conducted emissions on the line supply below the limits of standards EN 55011 group 1, class A or B and IEC/EN 61800/-3 category C1 or C2 (see page 10).

For ATV 61H●●●M3, ATV 61HD11M3X...HD45M3X and ATV 61H075N4...HD75N4 drives, the additional EMC filters can be mounted beside or under the device. They act as a support for the drives and are attached to them via tapped holes.

For ATV 61HD55M3X...HD90M3X and ATV 61HD90N4...HC63N4 drives, the additional EMC filters can only be mounted beside the drive.

(1) Maximum lengths for shielded cables connecting motors to drives, for a factory-set switching frequency of 2.5 or 4 kHz depending on the rating (see page 12). If motors are connected in parallel, it is the sum of the cable lengths that should be taken into account.

(2) See page 10.

(3) LF: low switching frequency. HF: high switching frequency.

(4) The LF and HF frequencies depend on the drive rating.

Drives	Switching frequency	
	LF	HF
	kHz	kHz
ATV 61H●●●M3 ATV 61H075N4...HD30N4	4	4.1...16
ATV 61HD37N4...HD75N4	2...2.5	2.6...12
ATV 61HD90N4...HC63N4	2...4	4.1...8
ATV 61HU30Y...HD30Y	2.5...4	4.1...6
ATV 61HD37Y...HC80Y	2.5	2.6...4.9

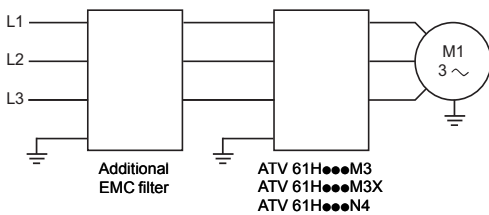

### Additional EMC input filters (continued)

#### Use according to the type of line supply

Use of these additional filters is only possible on TN (connected to neutral) and TT (neutral to earth) type networks.

Standard IEC/EN 61800-3, appendix D2.1, states that on IT networks (isolated or impedance earthed neutral), filters can cause permanent insulation monitors to operate in a random manner.

In addition, the effectiveness of additional filters on this type of network depends on the type of impedance between neutral and earth, and therefore cannot be predicted.

In the case of a machine which needs to be installed on an IT network, the solution would be to insert an isolation transformer and place the machine locally on a TN or TT network.

### General characteristics

EMC filter type			VW3 A4 401...409	VW3 A4 410...413
Conforming to standards			EN 133200	
Degree of protection			IP 20 and IP 41 on upper part	IP 00 IP 30 with kits VW3 A9 601, 602
Maximum relative humidity			93% without condensation or dripping water conforming to IEC 68-2-3	
Ambient air temperature around the device	Operation	°C	- 10...+ 50	- 25...+ 45
	Storage	°C	- 40...+ 65	- 25...+ 85
Maximum operating altitude		m	1000 derating 1000...3000 derating the current by 1% per additional 100 m. Limited to 2000 m for the "Corner Grounded" distribution network.	
Vibration resistance			1.5 mm peak to peak from 3...13 Hz, 1 gn peak from 13...150 Hz, in accordance with IEC 60068-2-6	
Shock resistance			15 gn for 11 ms conforming to IEC 60068-2-27	
Maximum nominal voltage	50/60 Hz three-phase	V	240 + 10% 480 + 10%	

### Connection characteristics

Maximum wire size and tightening torque			
VW3 A4 401			4 mm <sup>2</sup> (AWG 10) 0.6 Nm
VW3 A4 402			6 mm <sup>2</sup> (AWG 8) 1.5 Nm
VW3 A4 403			10 mm <sup>2</sup> (AWG 6) 1.5 Nm
VW3 A4 404			16 mm <sup>2</sup> (AWG 4) 2 Nm
VW3 A4 405...407			50 mm <sup>2</sup> (AWG 0) 6 Nm
VW3 A4 408			150 mm <sup>2</sup> (300 kcmil) 25 Nm
VW3 A4 409			25 mm <sup>2</sup> (AWG 2) 4 Nm
VW3 A4 410...412			Connected on a bar, M10 —
VW3 A4 413			Connected on a bar, 2 x M12 —

## Variable speed drives

## Altivar 61: EMC filters

## Option: additional input filters

Additional EMC input filters for ATV 61H●●●●●									
Drives	Maximum length of shielded cable (1)				In (2)	If (3)	Loss (4)	Reference	Weight
	EN 55011 (5) class A Gr1		EN 55011 (5) class B Gr1						
	IEC/EN 61800-3 category C2 (5)		IEC/EN 61800-3 category C1 (5)						
	LF (6)	HF (6)	LF (6)	HF (6)	A	mA	W	kg	
<b>Three-phase supply voltage: 200...240 V 50/60 Hz</b>									
ATV 61H075M3, HU15M3	100	50	50	20	12	4	10	VW3 A4 401	2.200
ATV 61HU22M3...HU40M3	100	50	50	20	26	4.4	18	VW3 A4 402	4.000
ATV 61HU55M3	100	50	50	20	35	3	24	VW3 A4 403	5.800
ATV 61HU75M3	100	50	50	20	46	10	19	VW3 A4 404	7.000
ATV 61HD11M3X, HD15M3X	200	100	50	25	72	33	34	VW3 A4 405	12.000
ATV 61HD18M3X, HD22M3X	200	100	50	25	90	33	34	VW3 A4 406	15.000
ATV 61HD30M3X...HD45M3X	200	100	50	25	180	80	58	VW3 A4 408	40.000
ATV 61HD55M3X, HD75M3X	100	50	50	25	273	285	60	VW3 A4 410	22.000
ATV 61HD90M3X	100	50	50	25	336	500	125	VW3 A4 411	22.000
<b>Three-phase supply voltage: 380...480 V 50/60 Hz</b>									
ATV 61H075N4...HU22N4	100	50	50	20	12	7	5	VW3 A4 401	2.200
ATV 61HU30N4, HU40N	100	50	50	20	26	8	6	VW3 A4 402	4.000
ATV 61HU55N4, HU75N4	100	50	50	20	35	7	14	VW3 A4 403	5.800
ATV 61HD11N4	100	50	50	20	46	14	13	VW3 A4 404	7.000
ATV 61HD15N4 (7), HD18N4	300	200	100	100	72	60	14	VW3 A4 405	12.000
ATV 61HD22N4	300	200	100	100	90	60	11	VW3 A4 406	15.000
ATV 61HD30N4, HD37N4	300	200	100	100	92	60	30	VW3 A4 407	17.000
ATV 61HD45N4...HD75N4	300	200	100	100	180	140	58	VW3 A4 408	40.000
ATV 61HD90N4...HC16N4	300	150	50	25	273	500	60	VW3 A4 410	22.000
ATV 61HC22N4...HC31N4	300	150	50	25	546	500	125	VW3 A4 411	25.000
ATV 61HC40N4, HC50N4	300	150	50	25	728	500	210	VW3 A4 412	25.000
ATV 61HC63N4	300	150	50	25	1456	200	380	VW3 A4 413	34.000

(1) The filter selection tables give the maximum lengths for shielded cables connecting motors to drives for a switching frequency of 1 to 16 kHz (see page 12). These limits are given as examples only as they vary depending on the stray capacitance of the motors and the cables used. If motors are connected in parallel, it is the sum of the cable lengths that should be taken into account.

(2) Filter nominal current.

(3) Maximum earth leakage current at 230 V and at 400 V 50 Hz on a TT network.

(4) Via thermal dissipation.

(5) See page 10.

(6) LF: low switching frequency. HF: high switching frequency. These frequencies depend on the drive rating:

For drives	Switching frequency	
	LF kHz	HF kHz
ATV 61H●●●M3	4	4.1...16
ATV 61H075N4...HD11N4		
ATV 61HD11M3X, HD15M3X	3.5...4	4.1...12
ATV 61HD15N4...HD30N4		
ATV 61HD18M3X...HD45M3X	2...2.5	2.6...12
ATV 61HD37N4...HD75N4		
ATV 61HD55M3X...HD90M3X	2.5...4	4.1...8
ATV 61HD90N4...HC63N4	2...4	4.1...8

(7) It is possible to use a special filter VW3 A4 409 with a leakage current I (3) of 14 mA which enables a maximum motor cable length of 100 m.

## Variable speed drives

Altivar 61: EMC filters

Option: additional input filters

### IP 30 protection kits

Description	For filters	Reference	Weight kg
Mechanical device consisting of an IP 30 cover and cable clips	VW3A4 410, 411	VW3 A9 601	–
	VW3A4 412, 413	VW3 A9 602	–

The Altivar 61 drive includes as standard a software function used to limit overvoltages at the motor terminals. Depending on the cable lengths or the type of application, it may be necessary to use output filters:

- Motor chokes used to limit the dv/dt
- Sinus filters that are particularly effective for long cable runs

Cable length (2) (3)	10...50 m	50...100 m	100...150 m	150...300 m	300...600 m	600...1000 m
<b>Shielded cable</b>						
ATV 61H●●●M3 ATV 61H075N4...HD15N4 ATV 61W075N4...WD15N4 ATV 61W075N4C...WD15N4C	Software function (1)	Motor choke		–		
ATV 61H●●●M3X ATV 61HD18N4...HC63N4 ATV 61WD18N4...WD90N4 ATV 61WD18N4C...WD90N4C	Software function (1)	Motor choke		–		
<b>Unshielded cable</b>						
ATV 61H075M3, HU15M3 ATV 61H075N4...HU22N4 ATV 61W075N4...WU22N4 ATV 61W075N4C...WU22N4C	Software function (1)	Motor choke or sinus filter		–		
ATV 61HU22M3, HU30M3 ATV 61HU30N4...HU55N4 ATV 61WU30N4...WU55N4 ATV 61WU30N4C...WU55N4C	Software function (1)	Motor choke		Sinus filter	–	
ATV 61HU40M3...HU75M3 ATV 61HU75N4...HD15N4 ATV 61WU75N4...WD15N4 ATV 61WU75N4C...WD15N4C	Software function (1)	Motor choke		Sinus filter		
ATV 61HD11M3X...HD45M3X ATV 61HD18N4...HD75N4 ATV 61WD18N4...WD90N4 ATV 61WD18N4C...WD90N4C	Software function (1)			Motor choke	Sinus filter	
ATV 61HD55M3X...HD90M3X ATV 61HD90N4...HC63N4	Software function (1)			Motor choke	2 motor chokes in series	–

(1) The software function limits the overvoltage at the motor terminals to twice the DC bus voltage. For any application with braking cycles, the DC bus voltage rises to more than the supply voltage multiplied by  $\sqrt{2}$ . You must check the electrical characteristics of the motor before using this function.

(2) The cable length varies depending on the combination of variable speed drive/choke or sinus filter, see pages 166, 167 and 169. For an application with several motors connected in parallel, the cable length must include all cabling.

Recommended cable types:

- Shielded cables: "GORSE" cable, type GUOSTV-LS/LH; "PROTOFLEX" cable, type EMV2YSL CY
- Unshielded cables: "GORSE" cable, type H07 RN-F4GXX; "BELDEN" cable, type 2950X

(3) ATV 61H●●●Y drives:

- In combination with motor choke, see page 167
- In combination with sinus filter or if software function used, please consult your Regional Sales Office

### Motor chokes

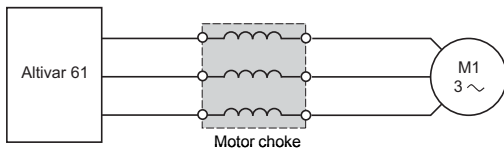

Altivar 61 drives have been developed to operate with the following maximum motor cable lengths:

For drives	Maximum length of motor cable (1)	
	Shielded cable	Unshielded cable
	m	m
ATV 61H●●●M3	50	100
ATV 61HD11M3X, HD15M3X		
ATV 61H075N4...HD18N4		
ATV 61W075N4...WD18N4		
ATV 61W075N4C...WD18N4C		
ATV 61HD18M3X...HD90M3X	100	200
ATV 61HD22N4...HC63N4		
ATV 61WD22N4...WD90N4		
ATV 61WD22N4C...WD90N4C		
ATV 61HU30Y...HD90Y	10	10
ATV 61HC11Y...HC80Y	15	30

The motor choke enables operation with motor cables above these maximum lengths and/or limits the dv/dt at the motor terminals:

- To 500 V/μs for three-phase line supplies of 200...400 V and 380...480 V
- To 1000 V/μs for three-phase line supplies of 500...690 V

It is also used to:

- Limit overvoltages on the motor terminals to:
  - 1000 V at 400 V ~ (rms value)
  - 1150 V at 460 V ~ (rms value)
  - 1800 V at 690 V ~ (rms value)
- Filter interference caused by opening a contactor placed between the filter and the motor
- Reduce the motor earth leakage current

### General characteristics (2)

Type of choke			VW3 A5 101...103	VW3 A5 104...108
Maximum drive switching frequency	ATV 61H●●●M3 ATV 61HD11M3X, HD15M3X ATV 61H075N4...HD30N4 ATV 61HU30Y...HD30Y ATV 61W075N4...WD90N4 ATV 61W075N4C...WD90N4C	kHz	4	
	ATV 61HD18M3X...HD90M3X ATV 61HD37N4...HC63N4 ATV 61HD37Y...HC80Y	kHz	2.5	
Maximum drive output frequency		Hz	100	
Degree of protection			IP 00	IP 00 IP 20 with kits VW3 A9 612 and VW3 A9 613
Thermal protection			By temperature-controlled switch	—
Temperature-controlled switch (3)	Tripping temperature	°C	125	—
	Maximum voltage	V	250 ~	—
	Maximum current	A	0.5	—
Ambient air temperature around the device	Operation	°C	- 10...+ 50	
	Storage	°C	- 25...+ 70	

### Connection characteristics

Maximum wire size and tightening torque	VW3 A5 101, 102	10 mm <sup>2</sup> (AWG 6) 1.5 Nm
	VW3 A5 103	Connected on a bar, Ø 9 mm —
	VW3 A5 104, 105	Connected on a tag connector, M10 —
	VW3 A5 106, 107	Connected on a tag connector, 2 x M12 —
	VW3 A5 108	Connected on a tag connector, 3 x M12 —

(1) These values are given for a switching frequency of 2.5 or 4 kHz depending on the rating.

(2) Choke performance is ensured by not exceeding the cable lengths stated above. For an application with several motors connected in parallel, the cable length must include all cabling. If a cable longer than that recommended is used, the motor chokes may overheat.

(3) The switch should be connected in the sequence (use for signalling or in line contactor control).



# Variable speed drives

## Altivar 61: output filters

### Option: motor chokes



VW3A5 101

Motor chokes								
For drives	Maximum length of motor cable (1)		Loss W	Nominal current A	Sold in lots of	Unit reference	Weight kg	
	Shielded Un-shielded							
	m	m						
<b>Three-phase supply voltage: 200...240 V 50/60 Hz</b>								
ATV 61H075M3...HU22M3	150	300	150	12	–	VW3 A5 101	5.500	
ATV 61HU30M3...HU75M3	200	260	250	48	–	VW3 A5 102	8.000	
	300	300	350	90	–	VW3 A5 103	10.000	
ATV 61HD11M3X...HD22M3X	150	300	350	90	–	VW3 A5 103	10.000	
ATV 61HD30M3X...HD45M3X	150	300	430	215	3	VW3 A5 104	15.500	
ATV 61HD55M3X, HD75M3X	150	300	475	314	3	VW3 A5 105	32.000	
ATV 61HD90M3X	250	300	530	481	3	VW3 A5 106	58.000	
<b>Three-phase supply voltage: 380...480 V 50/60 Hz</b>								
ATV 61H075N4...HU40N4	75	90	150	12	–	VW3 A5 101	5.500	
ATV 61W075N4...WU40N4	85	95	250	48	–	VW3 A5 102	8.000	
ATV 61W075N4C...WU40N4C			350	90	–	VW3 A5 103	10.000	
			200	350	90	–	VW3 A5 103	10.000
ATV 61HU55N4...HD18N4	85	95	250	48	–	VW3 A5 102	8.000	
ATV 61WU55N4...WD18N4	160	200	350	90	–	VW3 A5 103	10.000	
ATV 61WU55N4C...WD18N4C			430	215	3	VW3 A5 104	15.500	
			300	430	215	3	VW3 A5 104	15.500
ATV 61HD22N4, HD30N4	140	170	350	90	–	VW3 A5 103	10.000	
ATV 61WD22N4, WD30N4	150	300	430	215	3	VW3 A5 104	15.500	
ATV 61WD22N4C, WD30N4C								
ATV 61HD37N4	97	166	350	90	–	VW3 A5 103	10.000	
ATV 61WD37N4	200	300	430	215	3	VW3 A5 104	15.500	
ATV 61WD37N4C								
ATV 61HD45N4...HD75N4	150	300	430	215	3	VW3 A5 104	15.500	
ATV 61WD45N4...WD75N4	200	300	430	215	3	VW3 A5 104	15.500	
ATV 61WD45N4C...WD75N4C								
ATV 61HD90N4								
ATV 61WD90N4	150	250	475	314	3	VW3 A5 105	32.000	
ATV 61WD90N4C								
ATV 61HC11N4, HC13N4	250	300	530	481	3	VW3 A5 106	58.000	
ATV 61HC16N4	250	300	530	481	3	VW3 A5 106	58.000	
ATV 61HC22N4	200	250	598	759	3	VW3 A5 107	93.000	
ATV 61HC25N4	200	250	598	759	3	VW3 A5 107	93.000	
ATV 61HC31N4	200	250	598	759	3	VW3 A5 107	93.000	
ATV 61HC40N4	Motor P 355 kW	200	250	598	759	3	VW3 A5 107	93.000
		250	300	682	1188	3	VW3 A5 108	120.000
ATV 61HC50N4	Motor P 400 kW	250	300	682	1188	3	VW3 A5 108	120.000
ATV 61HC63N4		250	300	682	1188	3	VW3 A5 108	120.000

(1) Maximum length given for a switching frequency of 2.5 or 4 kHz depending on the drive rating, see characteristics on page 165.

Motor chokes (continued)							
For drives	Maximum length of motor cable (1)		Loss W	Nominal current A	Sold in lots of	Unit reference	Weight kg
	Shielded	Unshielded					
Three-phase supply voltage: 500...690 V 50/60 Hz							
ATV 61HU30Y...HD11Y	36	44	150	12	–	VW3 A5 101	5.500
	41	46	250	48	–	VW3 A5 102	8.000
	77	97	350	90	–	VW3 A5 103	10.000
ATV 61HD15Y...HD30Y	41	46	250	48	–	VW3 A5 102	8.000
	77	97	350	90	–	VW3 A5 103	10.000
	97	145	430	215	3	VW3 A5 104	15.500
ATV 61HD37Y...HD75Y	68	82	350	90	–	VW3 A5 103	10.000
	73	145	430	215	3	VW3 A5 104	15.500
ATV 61HD90Y	73	145	430	215	3	VW3 A5 104	15.500
ATV 61HC11Y... HC16Y	50	250	430	215	3	VW3 A5 104	15.500
ATV 61HC20Y, HC25Y	50	250	475	314	3	VW3 A5 105	32.000
ATV 61HC31Y, HC40Y	50	250	530	759	3	VW3 A5 106	58.000
ATV 61HC50Y, HC63Y	50	250	598	759	3	VW3 A5 107	93.000
ATV 61HC80Y	50	250	682	1188	3	VW3 A5 108	120.000
IP 20 protection kits							
Description	For motor chokes		Reference			Weight kg	
Mechanical kit including an IP 20 cover and cable clamps	VW3 A5 104, 105		VW3 A9 612			–	
	VW3 A5 106...108		VW3 A9 613			–	

(1) Maximum length given for:

- A switching frequency of 2.5 or 4 kHz depending on the drive rating, see characteristics on page 165
- A three-phase 690 V 50 Hz line supply voltage.

### Sinus filters

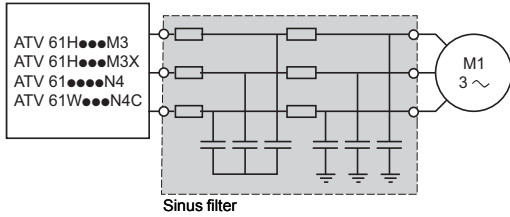

Sinus filters allow Altivar 61 drives to operate with longer motor cables (up to 1000 m).

For ATV 61H...M3, ATV 61HD11M3X...HD45M3X, ATV 61U15N4...D75N4, ATV 61WD90N4 and ATV 61WU15N4C...WD90N4C drives, they also allow the use of unshielded cables while still complying with the standards on radiated EMC emissions (EN 55011 class A Gr1 and IEC/EN 61800-3 category C2).

For ATV 61HD55M3X...HD90M3X and ATV 61HD90N4...HC63N4 drives, the sinus filter only operates with a voltage/frequency drive ratio.

The sinus filter is never compatible with the voltage sensorless flux vector control ratio.

**Note:** The Programming Manual must be referred to when setting up the sinus filter.

### Applications

For ATV 61H...M3, ATV 61HD11M3X...HD45M3X and ATV 61HU15N4...HD75N4 drives, applications requiring:

- Long cable runs
- Mechanical restrictions preventing the use of shielded cables
- An intermediate transformer between the drive and the motor
- Motors connected in parallel

For ATV 61HD55M3X...HD90M3X and ATV 61HD90N4...HC63N4 drives, applications requiring:

- An intermediate transformer between the drive and the motor

### General characteristics

Filter type		VW3 A5 201...206	VW3 A5 207...211
Degree of protection		IP 20	IP 00
Atmospheric pollution		3C2, 3B1, 3S1 conforming to IEC 721.3.3	
Degree of pollution		2 conforming to standard EN 50178	
Vibration resistance		1.5 mm from 3...13 Hz, 1 gn from 13...200 Hz, conforming to IEC 60068-2	
Shock resistance		15 gn for 11 ms conforming to IEC 60068-2-27	
Maximum relative humidity		95%	
Ambient air temperature around the device	Operation	°C - 10...+40 without derating 40...50°C derating the current by 1.5% per additional °C	
	Storage	°C - 40...+65	
Maximum operating altitude	m	1000 without derating 1000...3000 derating the current by 1% per additional 100 m	
Switching frequency	kHz	4...8	
Output frequency	Hz	0...100	
Voltage drop		< 10%	
Maximum voltage	V	500 ~	
Maximum current		1.5 x nominal current for 60 s	
Maximum motor cable length	Unshielded cable	m 600 or 1000 depending on the drive rating, see page 164	

### Connection characteristics

Maximum wire size and tightening torque	Model	Wire size (mm² / AWG)	Tightening torque (Nm)
	VW3 A5 201	4 mm² (AWG 10)	0.6 Nm
	VW3 A5 202	6 mm² (AWG 8)	1.5 Nm
	VW3 A5 203	10 mm² (AWG 6)	1.5 Nm
	VW3 A5 204	25 mm² (AWG 2)	4 Nm
	VW3 A5 205	50 mm² (AWG 0)	6 Nm
	VW3 A5 206, 207	95 mm² (AWG 4/0)	20 Nm
	VW3 A5 208, 209	Connected on a bar, Ø 11 mm	-
	VW3 A5 210	Connected on a bar, Ø 14 mm	-
	VW3 A5 211	Connected on a bar, 4 x Ø 11 mm	-

<b>Sinus filters</b>					
For drives	Nominal current	Loss at 100 Hz	Reference	Weight	
	A	W			kg
<b>Three-phase supply voltage: 200...240 V 50/60 Hz</b>					
ATV 61H075M3, HU15M3 (1)	11	50	VW3 A5 201	8.000	
ATV 61HU22M3, HU30M3	16	70	VW3 A5 202	11.000	
ATV 61HU40M3... HU75M3	33	120	VW3 A5 203	22.000	
ATV 61HD11M3X, HD15M3X	66	180	VW3 A5 204	45.000	
ATV 61HD18M3X, HD22M3X	95	250	VW3 A5 205	60.000	
ATV 61HD30M3X... HD45M3X	180	400	VW3 A5 206	120.000	
ATV 61HD55M3X, HD75M3X	300	1360	VW3 A5 208	165.000	
ATV 61HD90M3X	400	1900	VW3 A5 209	190.000	
<b>Three-phase supply voltage: 380...480 V 50/60 Hz</b>					
ATV 61HU15N4...HU40N4 (1)	11	50	VW3 A5 201	8.000	
ATV 61WU15N4...WU40N4					
ATV 61WU15N4C...WU40N4C					
ATV 61HU55N4	16	70	VW3 A5 202	11.000	
ATV 61WU55N4					
ATV 61WU55N4C					
ATV 61HU75N4...HD15N4	33	120	VW3 A5 203	22.000	
ATV 61WU75N4...WD15N4					
ATV 61WU75N4C...WD15N4C					
ATV 61HD18N4... HD30N4	66	180	VW3 A5 204	45.000	
ATV 61WD18N4... WD30N4					
ATV 61WD18N4C... WD30N4C					
ATV 61HD37N4, HD45N4	95	250	VW3 A5 205	60.000	
ATV 61WD37N4, WD45N4					
ATV 61WD37N4C, WD45N4C					
ATV 61HD55N4, HD75N4	180	400	VW3 A5 206	120.000	
ATV 61WD55N4, WD75N4					
ATV 61WD55N4C, WD75N4C					
ATV 61HD90N4, HC11N4	200	945	VW3 A5 207	130.000	
ATV 61WD90N4					
ATV 61WD90N4C					
ATV 61HC13N4, HC16N4	300	1360	VW3 A5 208	165.000	
ATV 61HC22N4	400	1900	VW3 A5 209	190.000	
ATV 61HC25N4	600	2370	VW3 A5 210	260.000	
ATV 61HC31N4	600	2370	VW3 A5 210	260.000	
ATV 61HC40N4	Motor P 355 kW	600	2370	VW3 A5 210	260.000
	Motor P 400 kW	1200	5150	VW3 A5 211	600.000
ATV 61HC50N4		1200	5150	VW3 A5 211	600.000
ATV 61HC63N4		1200	5150	VW3 A5 211	600.000

(1) For ATV 61H075M3, HU15M3 and ATV 61HU15N4 drives, it is advisable to use a lower power motor with a sinus filter.

# Variable speed drives

## Altivar 61

Supply voltage 200...240 V 50/60 Hz

**Table showing possible combinations of Altivar 61 UL Type 1/IP 20 drive options**

Motor		Drive	Options					
kW	HP		DC choke	Line choke	Additional EMC input filter	IP 30 kit for EMC filter	Motor choke	IP 20 kit for motor choke
<b>Single-phase supply voltage: 200...240 V 50/60 Hz</b>								
0.37	0.5	ATV 61H075M3	VW3A4 503	–	VW3A4 401	–	VW3A5 101	–
0.75	1	ATV 61HU15M3	VW3A4 505	–	VW3A4 401	–	VW3A5 101	–
1.5	2	ATV 61HU22M3	VW3A4 506	–	VW3A4 402	–	VW3A5 101	–
2.2	3	ATV 61HU30M3	VW3A4 507	–	VW3A4 402	–	VW3A5 102, 103	–
3	–	ATV 61HU40M3	VW3A4 508	VW3A58501	VW3A4 402	–	VW3A5 102, 103	–
4	5	ATV 61HU55M3	VW3A4 508	VW3A58502	VW3A4 403	–	VW3A5 102, 103	–
5.5	7.5	ATV 61HU75M3	VW3A4 509	VW3A58502	VW3A4 404	–	VW3A5 102, 103	–
<b>Three-phase supply voltage: 200...240 V 50/60 Hz</b>								
0.75	1	ATV 61H075M3	VW3A4 503	VW3A4 551	VW3A4 401	–	VW3A5 101	–
1.5	2	ATV 61HU15M3	VW3A4 505	VW3A4 552	VW3A4 401	–	VW3A5 101	–
2.2	3	ATV 61HU22M3	VW3A4 506	VW3A4 552	VW3A4 402	–	VW3A5 101	–
3	–	ATV 61HU30M3	VW3A4 507	VW3A4 553	VW3A4 402	–	VW3A5 102, 103	–
4	5	ATV 61HU40M3	VW3A4 508	VW3A4 554	VW3A4 402	–	VW3A5 102, 103	–
5.5	7.5	ATV 61HU55M3	VW3A4 508	VW3A4 554	VW3A4 403	–	VW3A5 102, 103	–
7.5	10	ATV 61HU75M3	VW3A4 509	VW3A4 555	VW3A4 404	–	VW3A5 102, 103	–
11	15	ATV 61HD11M3X	VW3A4 510	VW3A4 555	VW3A4 405	–	VW3A5 103	–
15	20	ATV 61HD15M3X	VW3A4 510	VW3A4 556	VW3A4 405	–	VW3A5 103	–
18.5	25	ATV 61HD18M3X	VW3A4 511	VW3A4 557	VW3A4 406	–	VW3A5 103	–
22	30	ATV 61HD22M3X	VW3A4 511	VW3A4 557	VW3A4 406	–	VW3A5 103	–
30	40	ATV 61HD30M3X	VW3A4 512	VW3A4 557	VW3A4 408	–	VW3A5 104	VW3A9 612
37	50	ATV 61HD37M3X	VW3A4 512	VW3A4 557	VW3A4 408	–	VW3A5 104	VW3A9 612
45	60	ATV 61HD45M3X	VW3A4 512	VW3A4 557	VW3A4 408	–	VW3A5 104	VW3A9 612
55	75	ATV 61HD55M3X	–	VW3A4 559 (1)	VW3A4 410	VW3A9 601	VW3A5 105	VW3A9 612
75	100	ATV 61HD75M3X	–	VW3A4 568 (1)	VW3A4 410	VW3A9 601	VW3A5 105	VW3A9 612
90	125	ATV 61HD90M3X	–	VW3A4 569 (1)	VW3A4 411	VW3A9 601	VW3A5 106	VW3A9 613
<b>Pages</b>		20	149	153	162	163	166	167

(1) For VW3 A4 559, 568 and 569 line chokes, you should order a drive without a DC choke, by adding a **D** at the end of the reference.  
 For example: **ATV 61HD55M3X** becomes **ATV 61HD55M3XD**, see page 24.

Sinus filter	Braking resistor	Control card fan kit	DNV kit	Kit for UL Type 1 conformity (outside enclosure)	Kit for IP 21 or IP 31 conformity (outside enclosure)	Kit for flush-mounting (in dust and damp proof enclosure)
VW3 A5 201	VW3 A7 701	–	VW3 A9 621	VW3 A9 201	VW3 A9 101	VW3 A9 501
VW3 A5 201	VW3 A7 702	–	VW3 A9 621	VW3 A9 201	VW3 A9 101	VW3 A9 501
VW3 A5 202	VW3 A7 702	–	VW3 A9 622	VW3 A9 202	VW3 A9 102	VW3 A9 502
VW3 A5 202	VW3 A7 703	–	VW3 A9 622	VW3 A9 202	VW3 A9 102	VW3 A9 502
VW3 A5 203	VW3 A7 703	–	VW3 A9 622	VW3 A9 202	VW3 A9 102	VW3 A9 502
VW3 A5 203	VW3 A7 704	–	VW3 A9 623	VW3 A9 203	VW3 A9 103	VW3 A9 503
VW3 A5 203	VW3 A7 704	–	VW3 A9 624	VW3 A9 204	VW3 A9 104	VW3 A9 504
VW3 A5 201	VW3 A7 701	–	VW3 A9 621	VW3 A9 201	VW3 A9 101	VW3 A9 501
VW3 A5 201	VW3 A7 702	–	VW3 A9 621	VW3 A9 201	VW3 A9 101	VW3 A9 501
VW3 A5 202	VW3 A7 702	–	VW3 A9 622	VW3 A9 202	VW3 A9 102	VW3 A9 502
VW3 A5 202	VW3 A7 703	–	VW3 A9 622	VW3 A9 202	VW3 A9 102	VW3 A9 502
VW3 A5 203	VW3 A7 703	–	VW3 A9 622	VW3 A9 202	VW3 A9 102	VW3 A9 502
VW3 A5 203	VW3 A7 704	–	VW3 A9 623	VW3 A9 203	VW3 A9 103	VW3 A9 503
VW3 A5 203	VW3 A7 704	–	VW3 A9 624	VW3 A9 204	VW3 A9 104	VW3 A9 504
VW3 A5 204	VW3 A7 705	–	VW3 A9 625	VW3 A9 205	VW3 A9 105	VW3 A9 505
VW3 A5 204	VW3 A7 706	–	VW3 A9 625	VW3 A9 205	VW3 A9 105	VW3 A9 505
VW3 A5 205	VW3 A7 707	VW3 A9 404	VW3 A9 626	VW3 A9 206	VW3 A9 106	VW3 A9 506
VW3 A5 205	VW3 A7 707	VW3 A9 404	VW3 A9 626	VW3 A9 206	VW3 A9 106	VW3 A9 506
VW3 A5 206	VW3 A7 708	VW3 A9 406	VW3 A9 628	VW3 A9 217	VW3 A9 117	VW3 A9 508
VW3 A5 206	VW3 A7 709	VW3 A9 406	VW3 A9 628	VW3 A9 217	VW3 A9 117	VW3 A9 508
VW3 A5 206	VW3 A7 709	VW3 A9 406	VW3 A9 628	VW3 A9 217	VW3 A9 117	VW3 A9 508
VW3 A5 208	VW3 A7 713	–	VW3 A9 629 (1)	VW3 A9 209	VW3 A9 109	VW3 A9 510
VW3 A5 208	VW3 A7 713	–	VW3 A9 629 (1)	VW3 A9 209	VW3 A9 109	VW3 A9 510
VW3 A5 209	VW3 A7 714	–	VW3 A9 631 (1)	VW3 A9 210	VW3 A9 110	VW3 A9 511
169	140	27	28	30	31	32

(1) For VW3 A9 629 and VW3 A9 631 kits, you should order a drive without a DC choke, by adding a **D** at the end of the reference.  
For example: **ATV 61HD55M3X** becomes **ATV 61HD55M3XD**, see page 24.

# Variable speed drives

## Altivar 61

Supply voltage 380...480 V 50/60 Hz

Table showing possible combinations of Altivar 61 UL Type 1/IP 20 drive options

Motor		Drive	Options						
kW	HP		DC choke	Line choke	Passive filter(1)	Additional EMC input filter	IP 30 kit for EMC filter	Motor choke	IP 20 kit for motor choke
<b>Three-phase supply voltage: 380...480 V 50/60 Hz</b>									
0.75	1	ATV 61H075N4	VW3A4 501	VW3A4 551	VW3A4 6●1	VW3A4 401	–	VW3A5 101, 102, 103	–
1.5	2	ATV 61HU15N4	VW3A4 502	VW3A4 551	VW3A4 6●1	VW3A4 401	–	VW3A5 101, 102, 103	–
2.2	3	ATV 61HU22N4	VW3A4 503	VW3A4 552	VW3A4 6●1	VW3A4 401	–	VW3A5 101, 102, 103	–
3	–	ATV 61HU30N4	VW3A4 503	VW3A4 552	VW3A4 6●1	VW3A4 402	–	VW3A5 101, 102, 103	–
4	5	ATV 61HU40N4	VW3A4 504	VW3A4 552	VW3A4 6●2	VW3A4 402	–	VW3A5 101, 102, 103	–
5.5	7.5	ATV 61HU55N4	VW3A4 505	VW3A4 553	VW3A4 6●2	VW3A4 403	–	VW3A5 101, 103, 104	VW3A9 612
7.5	10	ATV 61HU75N4	VW3A4 506	VW3A4 553	VW3A4 6●3	VW3A4 403	–	VW3A5 102, 103, 104	VW3A9 612
11	15	ATV 61HD11N4	VW3A4 507	VW3A4 554	VW3A4 6●3	VW3A4 404	–	VW3A5 102, 103, 104	VW3A9 612
15	20	ATV 61HD15N4	VW3A4 508	VW3A4 554	VW3A4 6●4	VW3A4 405	–	VW3A5 102, 103, 104	VW3A9 612
18.5	25	ATV 61HD18N4	VW3A4 508	VW3A4 555	VW3A4 6●5	VW3A4 405	–	VW3A5 102, 103, 104	VW3A9 612
22	30	ATV 61HD22N4	VW3A4 510	VW3A4 555	VW3A4 6●6	VW3A4 406	–	VW3A5 103, 104	VW3A9 612
30	40	ATV 61HD30N4	VW3A4 510	VW3A4 556	VW3A4 6●7	VW3A4 407	–	VW3A5 103, 104	VW3A9 612
37	50	ATV 61HD37N4	VW3A4 510	VW3A4 556	VW3A4 6●7	VW3A4 407	–	VW3A5 103, 104	VW3A9 612
45	60	ATV 61HD45N4	VW3A4 511	VW3A4 556	VW3A4 6●8	VW3A4 408	–	VW3A5 104	VW3A9 612
55	75	ATV 61HD55N4	VW3A4 511	VW3A4 556	VW3A4 6●8	VW3A4 408	–	VW3A5 104	VW3A9 612
75	100	ATV 61HD75N4	VW3A4 511	VW3A4 557	VW3A4 6●9	VW3A4 408	–	VW3A5 104	VW3A9 612
90	125	ATV 61HD90N4	–	VW3A4 558 (2)	VW3A4 6●9	VW3A4 410	VW3A9 601	VW3A5 104	VW3A9 612
110	150	ATV 61HC11N4	–	VW3A4 559 (2)	VW3A4 6●0	VW3A4 410	VW3A9 601	VW3A5 105	VW3A9 612
132	200	ATV 61HC13N4	–	VW3A4 560 (2)	VW3A4 6●1	VW3A4 410	VW3A9 601	VW3A5 105	VW3A9 612
160	250	ATV 61HC16N4	–	VW3A4 568 (2)	VW3A4 6●2	VW3A4 410	VW3A9 601	VW3A5 106	VW3A9 613
200	300	ATV 61HC22N4	–	VW3A4 561 (2)	VW3A4 6●3	VW3A4 411	VW3A9 601	VW3A5 106	VW3A9 613
220	350	ATV 61HC22N4	–	VW3A4 569 (2)	VW3A4 6●3	VW3A4 411	VW3A9 601	VW3A5 106	VW3A9 613
250	400	ATV 61HC25N4	–	VW3A4 569 (2)	VW3A4 6●1	VW3A4 411	VW3A9 601	VW3A5 107	VW3A9 613
280	450	ATV 61HC31N4	–	VW3A4 564 (2)	VW3A4 6●2	VW3A4 411	VW3A9 601	VW3A5 107	VW3A9 613
315	500	ATV 61HC31N4	–	VW3A4 564 (2)	VW3A4 6●2	VW3A4 411	VW3A9 601	VW3A5 107	VW3A9 613
355	–	ATV 61HC40N4	–	VW3A4 565 (2)	VW3A4 6●2	VW3A4 412	VW3A9 602	VW3A5 107	VW3A9 613
400	600	ATV 61HC40N4	–	VW3A4 565 (2)	VW3A4 6●9	VW3A4 412	VW3A9 602	VW3A5 108	VW3A9 613
500	700	ATV 61HC50N4	–	VW3A4 569 (2)	VW3A4 6●2	VW3A4 412	VW3A9 602	VW3A5 108	VW3A9 613
560	800	ATV 61HC63N4	–	VW3A4 564 (2)	VW3A4 6●3	VW3A4 413	VW3A9 602	VW3A5 108	VW3A9 613
630	900	ATV 61HC63N4	–	VW3A4 564 (2)	VW3A4 6●3	VW3A4 413	VW3A9 602	VW3A5 108	VW3A9 613
<b>Pages</b>		21	149	154	156	162	163	166	167

(1) There are special passive filters for a 460 V ~ supply, see pages 158 and 159.

(2) For VW3 A4 558...561, 564, 565, 568 and 569 line chokes, you should order a drive without a DC choke, by adding a **D** at the end of the reference.  
For example: **ATV 61HD90N4** becomes **ATV 61HD90N4D**, see page 24.

Sinus filter	Resistance braking unit	Braking resistor	Control card fan kit	DNV kit	Kit for UL Type 1 conformity (outside enclosure)	Kit for IP 21 or IP 31 conformity (outside enclosure)	Kit for flush-mounting (in dust and damp proof enclosure)
–	–	VW3A7 701	–	VW3A9 621	VW3A9 201	VW3A9 101	VW3A9 501
VW3A5 201	–	VW3A7 701	–	VW3A9 621	VW3A9 201	VW3A9 101	VW3A9 501
VW3A5 201	–	VW3A7 701	–	VW3A9 621	VW3A9 201	VW3A9 101	VW3A9 501
VW3A5 201	–	VW3A7 701	–	VW3A9 622	VW3A9 202	VW3A9 102	VW3A9 502
VW3A5 201	–	VW3A7 701	–	VW3A9 622	VW3A9 202	VW3A9 102	VW3A9 502
VW3A5 202	–	VW3A7 702	–	VW3A9 623	VW3A9 203	VW3A9 103	VW3A9 503
VW3A5 203	–	VW3A7 702	–	VW3A9 623	VW3A9 203	VW3A9 103	VW3A9 503
VW3A5 203	–	VW3A7 703	–	VW3A9 624	VW3A9 204	VW3A9 104	VW3A9 504
VW3A5 203	–	VW3A7 703	–	VW3A9 625	VW3A9 205	VW3A9 105	VW3A9 505
VW3A5 204	–	VW3A7 704	–	VW3A9 625	VW3A9 205	VW3A9 105	VW3A9 505
VW3A5 204	–	VW3A7 704	VW3A9 404	VW3A9 626	VW3A9 206	VW3A9 106	VW3A9 506
VW3A5 204	–	VW3A7 704	VW3A9 405	VW3A9 627	VW3A9 207	VW3A9 107	VW3A9 507
VW3A5 205	–	VW3A7 705	VW3A9 405	VW3A9 627	VW3A9 207	VW3A9 107	VW3A9 507
VW3A5 205	–	VW3A7 707	VW3A9 407	VW3A9 628	VW3A9 208	VW3A9 108	VW3A9 509
VW3A5 206	–	VW3A7 707	VW3A9 407	VW3A9 628	VW3A9 208	VW3A9 108	VW3A9 509
VW3A5 206	–	VW3A7 707	VW3A9 407	VW3A9 628	VW3A9 208	VW3A9 108	VW3A9 509
VW3A5 207	–	VW3A7 710	–	VW3A9 629 (1)	VW3A9 209	VW3A9 109	VW3A9 510
VW3A5 207	–	VW3A7 710	–	VW3A9 630(1)	VW3A9 209	VW3A9 109	VW3A9 510
VW3A5 208	–	VW3A7 711	–	VW3A9 632 (1)	VW3A9 210	VW3A9 110	VW3A9 511
VW3A5 208	–	VW3A7 711	–	VW3A9 634 (1)	VW3A9 211	VW3A9 111	VW3A9 512
VW3A5 209	–	VW3A7 712	–	VW3A9 635 (1)	VW3A9 212	VW3A9 112	VW3A9 513
VW3A5 209	–	VW3A7 712	–	VW3A9 636 (1)	VW3A9 212	VW3A9 112	VW3A9 513
VW3A5 210	VW3A7 101	VW3A7 715	–	VW3A9 637 (1)	VW3A9 213, 214	VW3A9 113, 114	VW3A9 514, 515
VW3A5 210	VW3A7 101	VW3A7 716	–	VW3A9 638 (1)	VW3A9 213, 214	VW3A9 113, 114	VW3A9 514, 515
VW3A5 210	VW3A7 101	VW3A7 716	–	VW3A9 638 (1)	VW3A9 213, 214	VW3A9 113, 114	VW3A9 514, 515
VW3A5 210	VW3A7 102	VW3A7 717	–	VW3A9 639 (1)	–	VW3A9 115	–
VW3A5 211	VW3A7 102	VW3A7 717	–	VW3A9 639 (1)	–	VW3A9 115	–
VW3A5 211	VW3A7 102	VW3A7 717	–	VW3A9 640 (1)	–	VW3A9 115	–
VW3A5 211	VW3A7 102	VW3A7 718	–	VW3A9 641 (1)	–	VW3A9 116	–
VW3A5 211	VW3A7 102	VW3A7 718	–	VW3A9 641 (1)	–	VW3A9 116	–
169	137	140	27	28	30	31	32

(1) For VW3 A9 629, 630, 632, 634...641 kits, you should order a drive without a DC choke, by adding a **D** at the end of the reference.  
For example: **ATV 61HD90N4** becomes **ATV 61HD90N4D**, see page 24.



# Variable speed drives

## Altivar 61

Supply voltage 380...480 V 50/60 Hz

**Table showing possible combinations of Altivar 61 UL Type 12/IP 54 drive options**

Motor		Drive	Options		
kW	HP		Line chokes	Passive filter (1)	Motor choke
<b>Three-phase supply voltage: 380...480 V 50/60 Hz</b>					
0.75	1	ATV 61W075N4 ATV 61W075N4C	VW3 A4 551	VW3 A4 6●1	VW3 A5 101, 102, 103
1.5	2	ATV 61WU15N4 ATV 61WU15N4C	VW3 A4 551	VW3 A4 6●1	VW3 A5 101, 102, 103
2.2	3	ATV 61WU22N4 ATV 61WU22N4C	VW3 A4 552	VW3 A4 6●1	VW3 A5 101, 102, 103
3	–	ATV 61WU30N4 ATV 61WU30N4C	VW3 A4 552	VW3 A4 6●1	VW3 A5 101, 102, 103
4	5	ATV 61WU40N4 ATV 61WU40N4C	VW3 A4 552	VW3 A4 6●2	VW3 A5 101, 102, 103
5.5	7.5	ATV 61WU55N4 ATV 61WU55N4C	VW3 A4 553	VW3 A4 6●2	VW3 A5 102, 103, 104
7.5	10	ATV 61WU75N4 ATV 61WU75N4C	VW3 A4 553	VW3 A4 6●3	VW3 A5 102, 103, 104
11	15	ATV 61WD11N4 ATV 61WD11N4C	VW3 A4 554	VW3 A4 6●3	VW3 A5 102, 103, 104
15	20	ATV 61WD15N4 ATV 61WD15N4C	VW3 A4 554	VW3 A4 6●4	VW3 A5 102, 103, 104
18.5	25	ATV 61WD18N4 ATV 61WD18N4C	VW3 A4 555	VW3 A4 6●5	VW3 A5 102, 103, 104
22	30	ATV 61WD22N4 ATV 61WD22N4C	VW3 A4 555	VW3 A4 6●6	VW3 A5 103, 104
30	40	ATV 61WD30N4 ATV 61WD30N4C	VW3 A4 556	VW3 A4 6●7	VW3 A5 103, 104
37	50	ATV 61WD37N4 ATV 61WD37N4C	VW3 A4 556	VW3 A4 6●7	VW3 A5 103, 104
45	60	ATV 61WD45N4 ATV 61WD45N4C	VW3 A4 556	VW3 A4 6●8	VW3 A5 104
55	75	ATV 61WD55N4	VW3 A4 556	VW3 A4 6●8	VW3 A5 104
55	75	ATV 61WD55N4C	VW3 A4 556	VW3 A4 6●8	VW3 A5 104
75	100	ATV 61WD75N4	VW3 A4 557	VW3 A4 6●9	VW3 A5 104
75	100	ATV 61WD75N4C	VW3 A4 557	VW3 A4 6●9	VW3 A5 104
90	125	ATV 61WD90N4	VW3 A4 558	VW3 A4 6●9	VW3 A5 104
90	125	ATV 61WD90N4C	VW3 A4 558	VW3 A4 6●9	VW3 A5 104
<b>Pages</b>		22	154	156	166

(1) There are special passive filters for a 460 V ~ supply, see pages 158 and 159.

<b>Kit for IP 20 motor choke VW3 A5 104</b>	<b>Sinus filters</b>	<b>Braking resistor</b>	<b>Ready-assembled IP 54 base plate</b>
–	VW3 A5 201	VW3 A7 701	VW3 A9 901
–	VW3 A5 201	VW3 A7 701	VW3 A9 901
–	VW3 A5 201	VW3 A7 701	VW3 A9 901
–	VW3 A5 201	VW3 A7 701	VW3 A9 901
–	VW3 A5 201	VW3 A7 701	VW3 A9 901
VW3 A9 612	VW3 A5 202	VW3 A7 701	VW3 A9 901
VW3 A9 612	VW3 A5 203	VW3 A7 702	VW3 A9 902
VW3 A9 612	VW3 A5 203	VW3 A7 702	VW3 A9 902
VW3 A9 612	VW3 A5 203	VW3 A7 703	VW3 A9 903
VW3 A9 612	VW3 A5 204	VW3 A7 703	VW3 A9 904
VW3 A9 612	VW3 A5 204	VW3 A7 704	VW3 A9 904
VW3 A9 612	VW3 A5 204	VW3 A7 704	VW3 A9 905
VW3 A9 612	VW3 A5 205	VW3 A7 704	VW3 A9 906
VW3 A9 612	VW3 A5 205	VW3 A7 705	VW3 A9 906
VW3 A9 612	VW3 A5 206	VW3 A7 706	VW3 A9 907
VW3 A9 612	VW3 A5 206	VW3 A7 706	VW3 A9 909
VW3 A9 612	VW3 A5 206	VW3 A7 706	VW3 A9 907
VW3 A9 612	VW3 A5 206	VW3 A7 706	VW3 A9 909
VW3 A9 612	VW3 A5 207	VW3 A7 706	VW3 A9 908
VW3 A9 612	VW3 A5 207	VW3 A7 706	VW3 A9 910
<b>167</b>	<b>169</b>	<b>140</b>	<b>26</b>

# Variable speed drives

## Altivar 61

Supply voltage 500...690 V 50/60 Hz

**Table showing possible combinations of ATV 61H●●●Y drive options**

Motor			Drive	Options				
				Line choke	Motor choke	IP 20 kit for motor choke	Resistance braking unit	Braking resistor
500 V kW	575 V HP	690 V kW						
<b>Three-phase supply voltage: 500...690 V 50/60 Hz</b>								
2.2	3	3	ATV 61HU30Y	VW3 A4 551	VW3 A5 101, 102, 103	–	–	VW3 A7 701
3	–	4	ATV 61HU40Y	VW3 A4 551	VW3 A5 101, 102, 103	–	–	VW3 A7 701
4	5	5.5	ATV 61HU55Y	VW3 A4 551	VW3 A5 101, 102, 103	–	–	VW3 A7 701
5.5	7.5	7.5	ATV 61HU75Y	VW3 A4 552	VW3 A5 101, 102, 103	–	–	VW3 A7 701
7.5	10	11	ATV 61HD11Y	VW3 A4 552	VW3 A5 101, 102, 103	–	–	VW3 A7 702
11	15	15	ATV 61HD15Y	VW3 A4 553	VW3 A5 102, 103, 104	VW3 A9 612	–	VW3 A7 702
15	20	18.5	ATV 61HD18Y	VW3 A4 553	VW3 A5 102, 103, 104	VW3 A9 612	–	VW3 A7 703
18.5	25	22	ATV 61HD22Y	VW3 A4 554	VW3 A5 102, 103, 104	VW3 A9 612	–	VW3 A7 703
22	30	30	ATV 61HD30Y	VW3 A4 554	VW3 A5 102, 103, 104	VW3 A9 612	–	VW3 A7 704
30	40	37	ATV 61HD37Y	VW3 A4 555	VW3 A5 103, 104	VW3 A9 612	–	VW3 A7 704
37	50	45	ATV 61HD45Y	VW3 A4 555	VW3 A5 103, 104	VW3 A9 612	–	VW3 A7 704
45	60	55	ATV 61HD55Y	VW3 A4 555	VW3 A5 103, 104	VW3 A9 612	–	VW3 A7 705
55	75	75	ATV 61HD75Y	VW3 A4 556	VW3 A5 103, 104	VW3 A9 612	–	VW3 A7 705
75	100	90	ATV 61HD90Y	VW3 A4 556	VW3 A5 104	VW3 A9 612	–	VW3 A7 707
90	125	110	ATV 61HC11Y	VW3 A4 570	VW3 A5 104	VW3 A9 612	–	VW3 A7 806
110	150	132	ATV 61HC13Y	VW3 A4 570	VW3 A5 104	VW3 A9 612	–	VW3 A7 806
132	–	160	ATV 61HC16Y	VW3 A4 571	VW3 A5 104	VW3 A9 612	–	VW3 A7 805
160	200	200	ATV 61HC20Y	VW3 A4 571	VW3 A5 105	VW3 A9 612	–	VW3 A7 805
200	250	250	ATV 61HC25Y	VW3 A4 560	VW3 A5 105	VW3 A9 612	VW3 A7 103	VW3 A7 806
250	350	315	ATV 61HC31Y	VW3 A4 572	VW3 A5 106	VW3 A9 613	VW3 A7 103	VW3 A7 716
315	450	400	ATV 61HC40Y	VW3 A4 572	VW3 A5 106	VW3 A9 613	VW3 A7 103	VW3 A7 814
400	550	500	ATV 61HC50Y	VW3 A4 568	VW3 A5 107	VW3 A9 613	VW3 A7 104	VW3 A7 717
500	700	630	ATV 61HC63Y	VW3 A4 572	VW3 A5 107	VW3 A9 613	VW3 A7 104	VW3 A7 718
630	800	800	ATV 61HC80Y	VW3 A4 572	VW3 A5 108	VW3 A9 613	VW3 A7 104	VW3 A7 816
<b>Pages</b>			23	154	167	167	137	141

Control card fan kit	DNV kit	Kit for UL Type 1 conformity (outside enclosure)	Kit for IP 21 or IP 31 conformity (outside enclosure)	Kit for flush-mounting (in dust and damp proof enclosure)
VW3 A9 404	VW3 A9 642	VW3 A9 206	VW3 A9 106	VW3 A9 506
VW3 A9 404	VW3 A9 642	VW3 A9 206	VW3 A9 106	VW3 A9 506
VW3 A9 404	VW3 A9 642	VW3 A9 206	VW3 A9 106	VW3 A9 506
VW3 A9 404	VW3 A9 642	VW3 A9 206	VW3 A9 106	VW3 A9 506
VW3 A9 404	VW3 A9 642	VW3 A9 206	VW3 A9 106	VW3 A9 506
VW3 A9 404	VW3 A9 642	VW3 A9 206	VW3 A9 106	VW3 A9 506
VW3 A9 404	VW3 A9 642	VW3 A9 206	VW3 A9 106	VW3 A9 506
VW3 A9 404	VW3 A9 642	VW3 A9 206	VW3 A9 106	VW3 A9 506
VW3 A9 404	VW3 A9 642	VW3 A9 206	VW3 A9 106	VW3 A9 506
VW3 A9 404	VW3 A9 642	VW3 A9 206	VW3 A9 106	VW3 A9 506
VW3 A9 407	VW3 A9 643	VW3 A9 208	VW3 A9 108	VW3 A9 509
VW3 A9 407	VW3 A9 643	VW3 A9 208	VW3 A9 108	VW3 A9 509
VW3 A9 407	VW3 A9 643	VW3 A9 208	VW3 A9 108	VW3 A9 509
VW3 A9 407	VW3 A9 643	VW3 A9 208	VW3 A9 108	VW3 A9 509
VW3 A9 407	VW3 A9 643	VW3 A9 208	VW3 A9 108	VW3 A9 509
–	VW3 A9 644	VW3 A9 211	VW3 A9 111	VW3 A9 512
–	VW3 A9 644	VW3 A9 211	VW3 A9 111	VW3 A9 512
–	VW3 A9 645	VW3 A9 211	VW3 A9 111	VW3 A9 512
–	VW3 A9 645	VW3 A9 211	VW3 A9 111	VW3 A9 512
–	VW3 A9 646	VW3 A9 213, 214	VW3 A9 113, 114	VW3 A9 514, 515
–	VW3 A9 647	VW3 A9 213, 214	VW3 A9 113, 114	VW3 A9 514, 515
–	VW3 A9 647	VW3 A9 213, 214	VW3 A9 113, 114	VW3 A9 514, 515
–	VW3 A9 648	–	VW3 A9 116	–
–	VW3 A9 649	–	VW3 A9 116	–
–	VW3 A9 649	–	VW3 A9 116	–
27	28	30	31	32

**List of options common to Altivar 61 drives**

Description	Reference	Page
<b>Logic input adaptor</b>		
Adaptor for 115 V ~ logic inputs	VW3 A3 101	26
<b>HMI terminal</b>		
Remote graphic display terminal	VW3 A1 101	108
<b>Encoder interface cards</b>		
With RS 422 compatible differential outputs	VW3 A3 401	111
With open collector outputs	VW3 A3 403, 404	111
With push-pull outputs	VW3 A3 405...407	111
<b>I/O extension cards (1)</b>		
Logic	VW3 A3 201	113
Extended	VW3 A3 202	113
<b>Multi-pump cards</b>		
Multi-pump card	VW3 A3 502	117
"Water solution" multi-pump card	VW3 A3 503	117
<b>Programmable card (1)</b>		
"Controller Inside" programmable card	VW3 A3 501	125
<b>PowerSuite software workshop</b>		
PowerSuite software workshop for PC	VW3 A8 104, 105	286

**List of communication cards (1)**

Description	Reference	Page
Modbus TCP	VW3 A3 310	128 and 292
EtherNet/IP	VW3 A3 316	129
Fipio	VW3 A3 311	130 and 296
Modbus Plus	VW3 A3 302	130 and 304
DeviceNet	VW3 A3 309	131
INTERBUS	VW3 A3 304	131
CC-Link	VW3 A3 317	131
Modbus/Uni-Telway	VW3 A3 303	132, 299 and 307
PROFIBUS DP	VW3 A3 307	133
LONWORKS	VW3 A3 312	133
METASYS N4	VW3 A3 313	133
APOGEE FLN	VW3 A3 314	133
BACNet	VW3 A3 315	133

(1) For card compatibility table, see page opposite.

**Card compatibility table (1)**

Type of card	Logic I/O VW3 A3 201	Extended I/O VW3 A3 202	Multi-pump VW3 A3 502, 503	Programmable "Controller inside" VW3 A3 501	Communication VW3 A3 3●●
Logic I/O VW3 A3 201					
Extended I/O VW3 A3 202					
Multi-pump VW3 A3 502, 503					
Programmable "Controller inside" VW3 A3 501					
Communication VW3 A3 3●●					

Possible to combine

Not possible to combine

(1) Maximum combination involving two types of card is 2.

# Variable speed drives

## Altivar 61

### UL Type 1/IP 20 drives

**ATV 61H●●●M3, ATV 61HD11M3X, HD15M3X, ATV 61H075N4...HD18N4**

Without option card      1 option card (1)      2 option cards (1)      Common front view

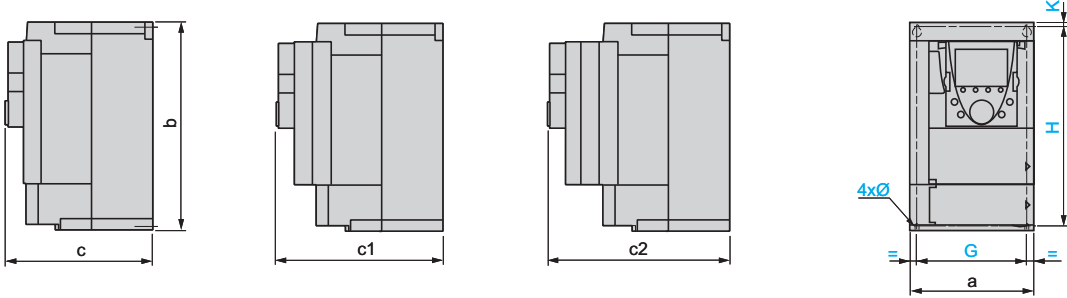

ATV 61H	a	b	c	c1	c2	G	H	K	Ø
075M3, U15M3, 075N4...U22N4	130	230	175	198	221	113.5	220	5	5
U22M3...U40M3, U30N4, U40N4	155	260	187	210	233	138	249	4	5
U55M3, U55N4, U75N4	175	295	187	210	233	158	283	6	5
U75M3, D11N4	210	295	213	236	259	190	283	6	6
D11M3X, D15M3X, D15N4, D18N4	230	400	213	236	259	210	386	8	6

**ATV 61HD18M3X...45M3X, ATV 61HD22N4...HD37N4, ATV 61HU30Y...HD30Y**

Without option card      1 option card (1)      2 option cards (1)      Common front view

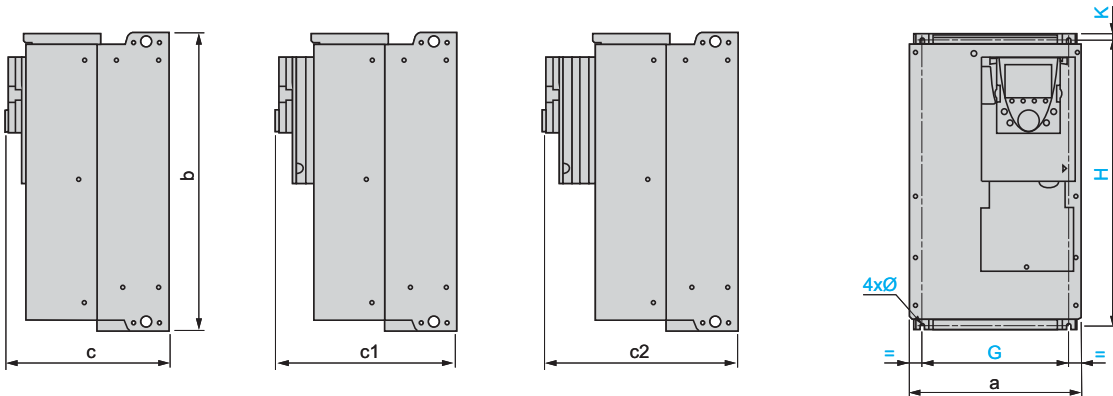

ATV 61H	a	b	c	c1	c2	G	H	K	Ø
D18M3X, D22M3X, D22N4, U30Y...D30Y	240	420	236	259	282	206	403	10	6
D30N4, D37N4	240	550	266	289	312	206	529	10	6
D30M3X...D45M3X	320	550	266	289	312	280	524	10	9

**ATV 61HD45N4...HD75N4, ATV 61HD37Y...HD90Y**

Without option card      1 option card (1)      2 option cards (1)      Common front view

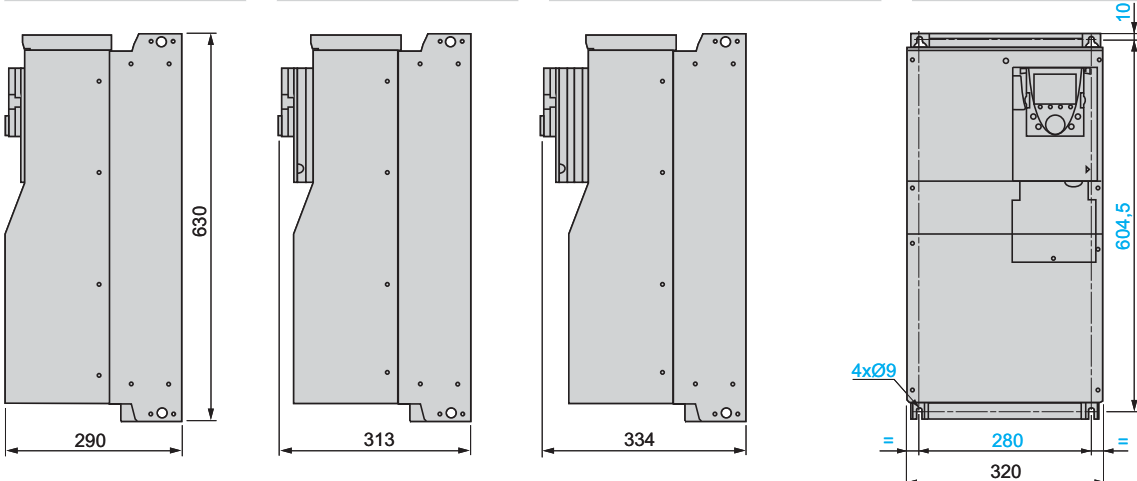

(1) Option cards: I/O extension cards, multi-pump cards, "Controller Inside" programmable card or communication cards.

# Variable speed drives

## Altivar 61

### UL Type 1/IP 20 drives

**ATV 61HD55M3X...HD90M3X, ATV 61HD90N4...HC31N4, ATV 61HC11Y...HC40Y**

With or without 1 option card (1)

2 option cards (1)

Common front view

ATV 61HC25N4, HC31N4 with braking unit VW3 A7 101

Front view

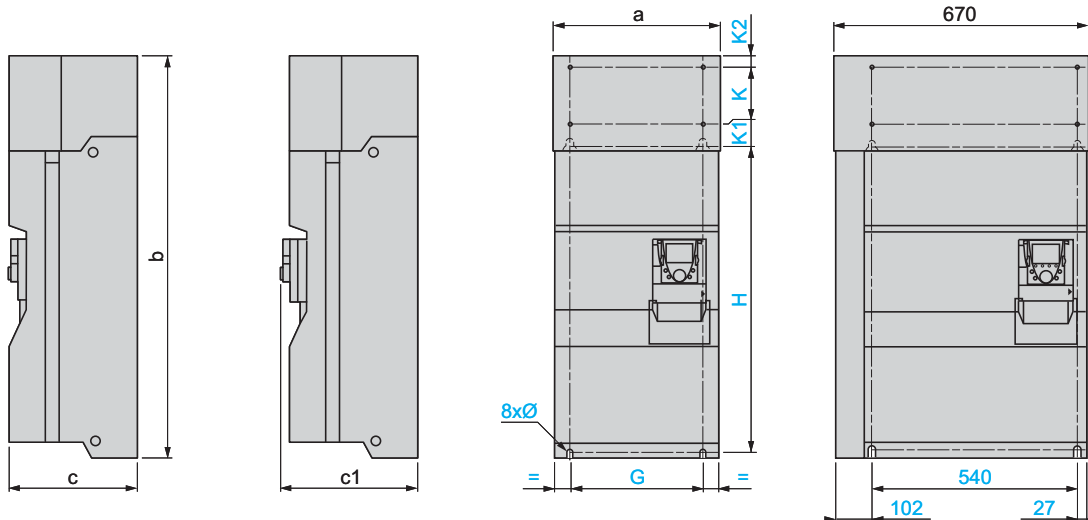

ATV 61H	a	b	c	c1	G	H	K	K1	K2	Ø
D55M3X, D75M3X D90N4, C11N4	320	920	377	392	250	650	150	75	30	11.5
D90M3X, C13N4	360	1022	377	392	298	758	150	75	30	11.5
C16N4, C11Y...C20Y	340	1190	377	392	285	920	150	75	30	11.5
C22N4	440	1190	377	392	350	920	150	75	30	11.5
C25N4, C31N4, C25Y...C40Y	595	1190	377	392	540	920	150	75	30	11.5

**ATV 61HC40N4...HC63N4, ATV 61HC50Y...HC80Y**

With or without 1 option card (1)

2 option cards (1)

ATV 61HC40N4, HC50N4

ATV 61HC63N4, HC50Y...HC80Y

Front view

Front view

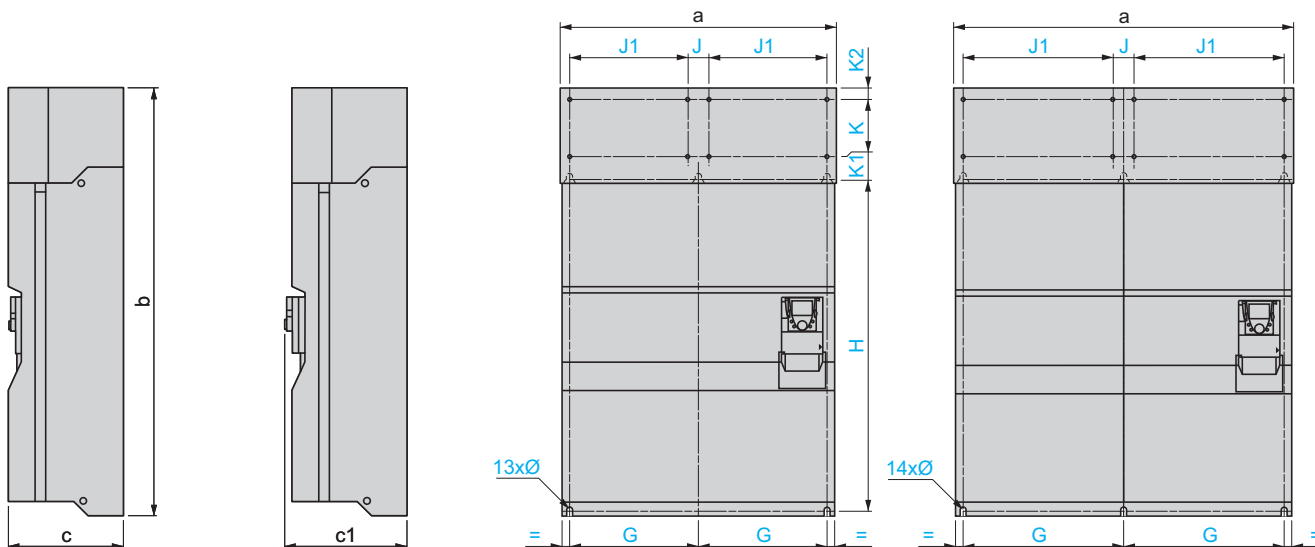

ATV 61H	a	b	c	c1	G	J	J1	H	K	K1	K2	Ø
C40N4, C50N4	890	1390	377	392	417	75	380	1120	150	75	30	11.5
C63N4, C50Y...C80Y	1120	1390	377	392	532	75	495	1120	150	75	30	11.5

(1) Option cards: I/O extension cards, multi-pump cards, "Controller Inside" programmable card or communication cards.



# Variable speed drives

## Altivar 61

### UL Type 1/IP 20 drives

**Variable speed drives without graphic display terminal**

**ATV 61H●●●M3Z, ATV 61HD11M3XZ, HD15M3XZ, ATV 61H075N4Z...HD18N4Z**

Without option card (1)      1 option card (1)      2 option cards (1)      **Common front view**

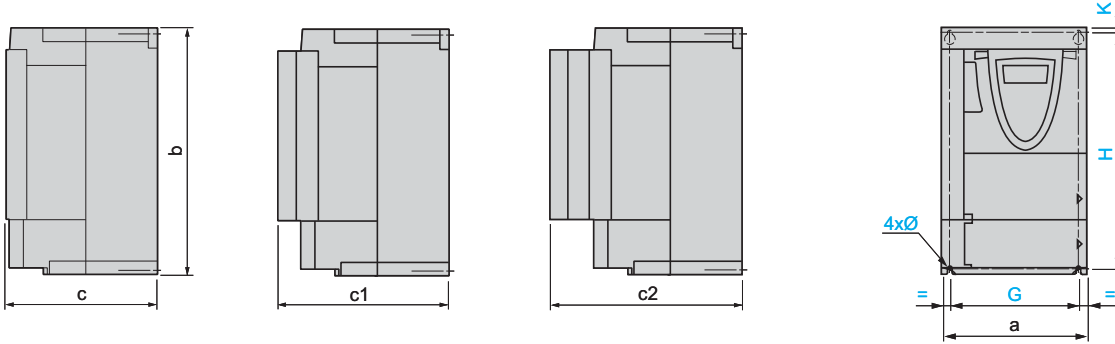

ATV 61H 075M3Z, U15M3Z, 075N4Z...U22N4Z U22M3Z...U40M3Z, U30N4Z, U40N4Z U55M3Z, U55N4Z, U75N4Z U75M3Z, D11N4Z D11M3XZ, D15M3XZ D15N4Z, D18N4Z	a	b	c	c1	c2	G	H	K	Ø
075M3Z, U15M3Z, 075N4Z...U22N4Z	130	230	149	172	195	113.5	220	5	5
U22M3Z...U40M3Z, U30N4Z, U40N4Z	155	260	161	184	207	138	249	4	5
U55M3Z, U55N4Z, U75N4Z	175	295	161	184	207	158	283	6	5
U75M3Z, D11N4Z	210	295	187	210	233	190	283	6	6
D11M3XZ, D15M3XZ D15N4Z, D18N4Z	230	400	187	210	233	210	386	8	6

**Variable speed drives without graphic display terminal**

**ATV 61HD18M3XZ...45M3XZ, ATV 61HD22N4Z...HD37N4Z**

Without option card      1 option card (1)      2 option cards (1)      **Common front view**

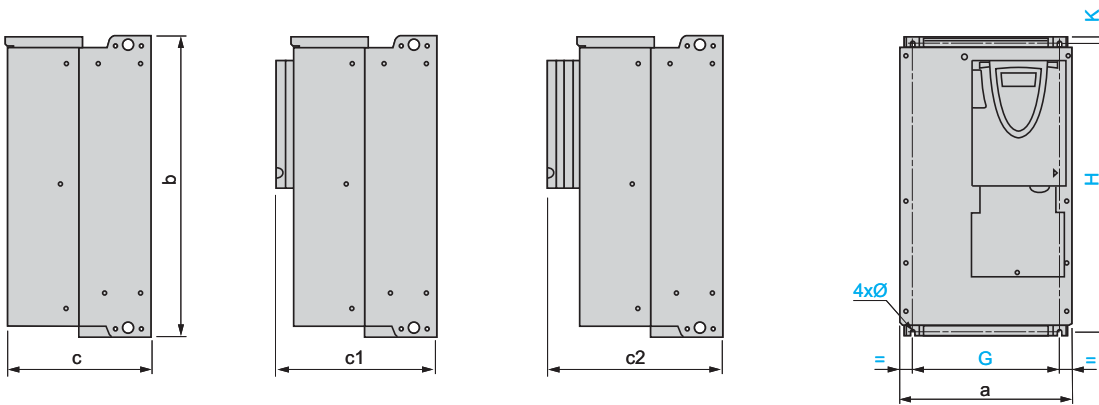

ATV 61H D18M3XZ, D22M3XZ, D22N4Z D30N4Z, D37N4Z D30M3XZ...D45M3XZ	a	b	c	c1	c2	G	H	K	Ø
D18M3XZ, D22M3XZ, D22N4Z	240	420	210	233	256	206	403	10	6
D30N4Z, D37N4Z	240	550	230	253	276	206	529	10	6
D30M3XZ...D45M3XZ	320	550	230	253	276	280	529	10	9

(1) Option cards: I/O extension cards, multi-pump cards, "Controller Inside" programmable card or communication cards.

**Variable speed drives without graphic display terminal**

**ATV 61HD45N4Z...HD75N4Z**

With or without 1 option card (1)

2 option cards (1)

Common front view

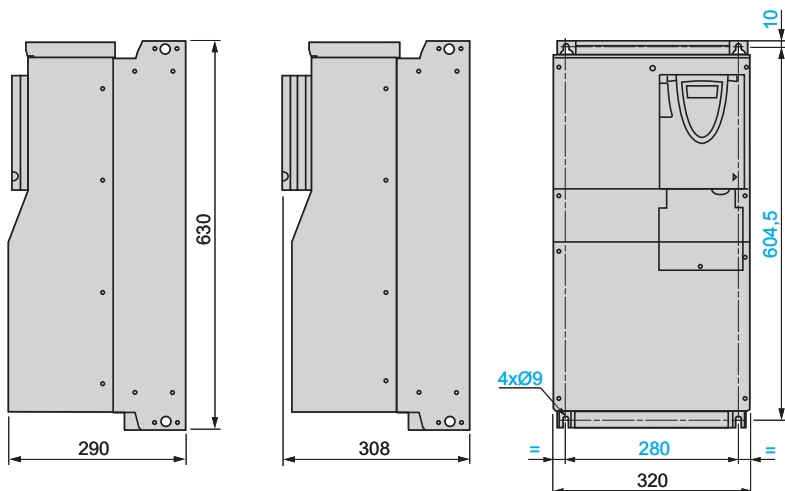

**Variable speed drives without DC choke**

**ATV 61HD55M3XD...HD90M3XD, ATV 61HD90N4D...HC31N4D**

With or without 1 option card (1)

2 option cards (1)

Common front view

**ATV 61HC25N4D, HC31N4D**  
with braking unit VW3 A7 101  
Front view

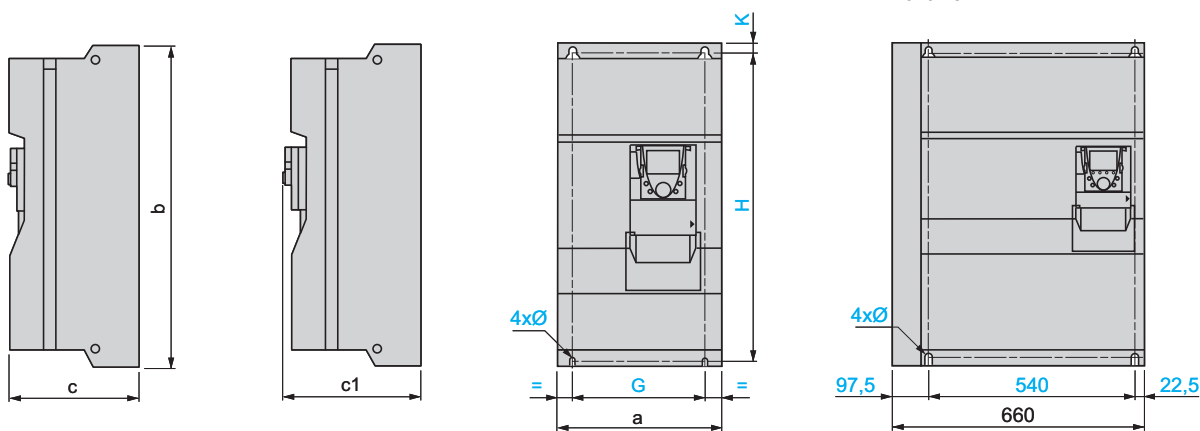

ATV 61H	a	b	c	c1	G	H	K	Ø
D55M3XD, D75M3XD D90N4D, C11N4D	310	680	377	392	250	650	15	11.5
D90M3XD, C13N4D	350	782	377	392	298	758	12	11.5
C16N4D	330	950	377	392	285	920	15	11.5
C22N4D	430	950	377	392	350	920	15	11.5
C25N4D, C31N4D	585	950	377	392	540	920	15	11.5

(1) Option cards: I/O extension cards, multi-pump cards, "Controller Inside" programmable card or communication cards.

# Variable speed drives

## Altivar 61

UL Type 1/IP 20 and UL Type 12/IP 54 drives

### Variable speed drives without DC choke

#### ATV 61HC40N4D...HC63N4D

With or without 1 option card (1)

2 option cards (1)

ATV 61HC40N4D, HC50N4D

ATV 61HC63N4D

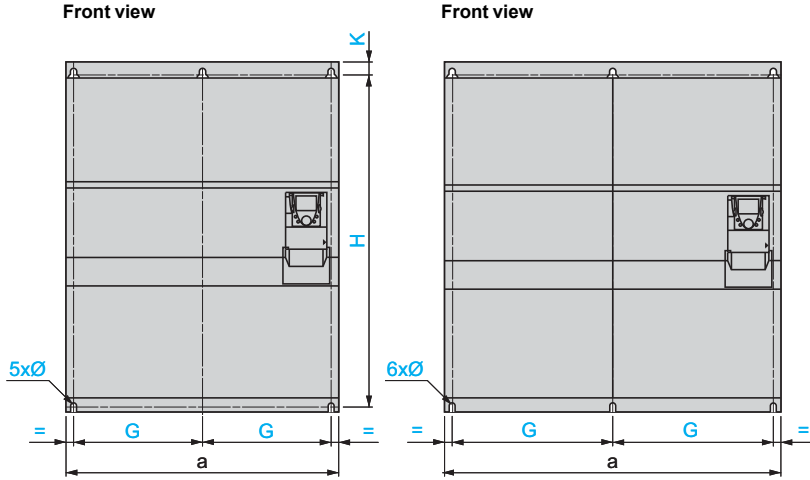
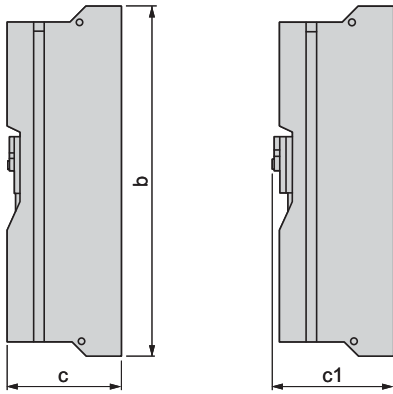

ATV 61H	a	b	c	c1	G	H	K	Ø
C40N4D, C50N4D	880	1150	377	392	417.5	1120	15	11.5
C63N4D	1110	1150	377	392	532.5	1120	15	11.5

(1) Option cards: I/O extension cards, multi-pump cards, "Controller Inside" programmable card or communication cards.

#### ATV 61W075N4...WD90N4, ATV 61W075N4C...WD90N4C

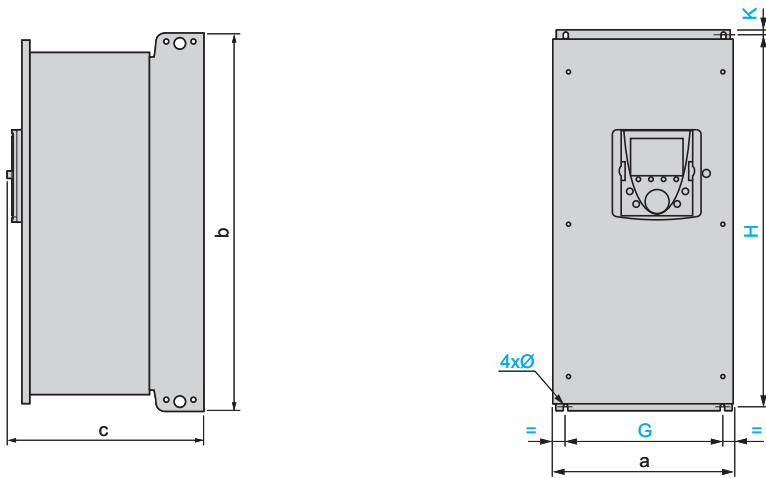

ATV 61W	a	b	c	G	H	K	Ø
075N4...U30N4	240	490	272	200	476	6	6
075N4C...U30N4C							
U40N4, U55N4	240	490	286	200	476	6	6
U40N4C, U55N4C							
U75N4, D11N4	260	525	286	220	511	6	6
U75N4C, D11N4C							
D15N4	295	560	315	250	544	8	6
D15N4C							
D18N4, D22N4	315	665	315	270	647	10	6
D18N4C, D22N4C							
D30N4	285	720	315	245	700	10	7
D30N4C							
D37N4, D45N4	285	880	343	245	860	10	7
D37N4C, D45N4C							
D55N4...D90N4	362	1000	364	300	975	10	9
D55N4C...D90N4C							

### EMC mounting plates (1)

For ATV 61H●●●M3, ATV 61HD11M3X, HD15M3X, ATV 61H075N4...HD18N4

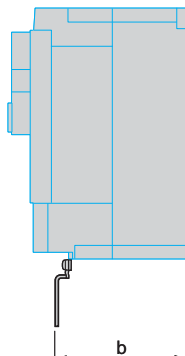
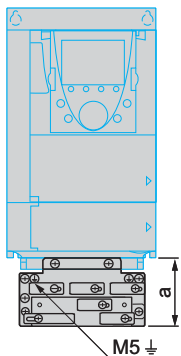

For ATV 61H	a	b
075M3...U15M3, 075N4...U22N4	83	70
U22M3...U40M3 U30N4, U40N4	95	85
U55M3 U55N4, U75N4	95	85
U75M3...D15M3X D11N4... D18N4	95	118

For ATV 61HD18M3X...HD45M3X, ATV 61HD22N4...HD75N4, ATV 61HU30Y...HD90Y

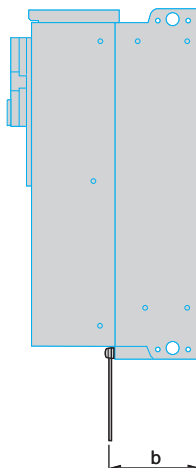
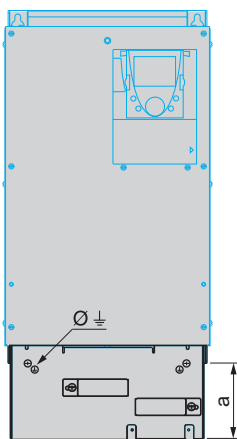

For ATV 61H	a	b	Ø
D18M3X, D22M3X, D22N4, U30Y...D30Y	122	120	M5
D30N4, D37N4	113	127	M5
D30M3X...D45M3X	118	128	M8
D45N4...D75N4 D37Y...D90Y	118	173	M8

(1) Supplied with the drive except for ATV 61HD55M3X...HD90M3X, ATV 61HD90N4...HC63N4 and ATV 60HC11Y...HC80Y. In the case of these drives, the mounting plate is supplied with the UL Type 1, IP 21 or IP 31 conformity kits, which must be ordered separately, see pages 30 and 31. For dimensions, see pages 189 and 190.

### Control card fan kits VW3 A9 404...407

#### Mounting recommendations

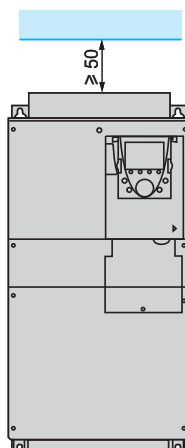
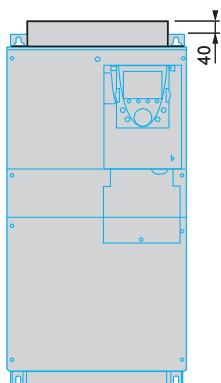

### DNV kits

#### VW3 A9 621...625

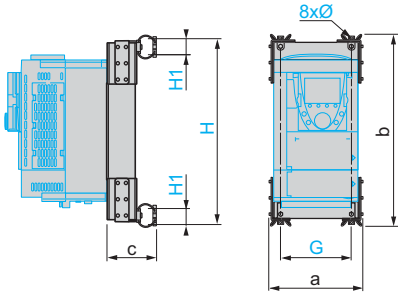

VW3	a	b	c	Ø	G	H	H1
A9 621	148	336	84	5.8	105	324.4	49.4
A9 622	173	370	105	5.8	130	358.4	49.4
A9 623	193	445	121	7	150	424.4	69.4
A9 624	228	455	120	7	190	434.4	69.4
A9 625	248	550	129	7	190	529.4	69.4

#### VW3 A9 626...628

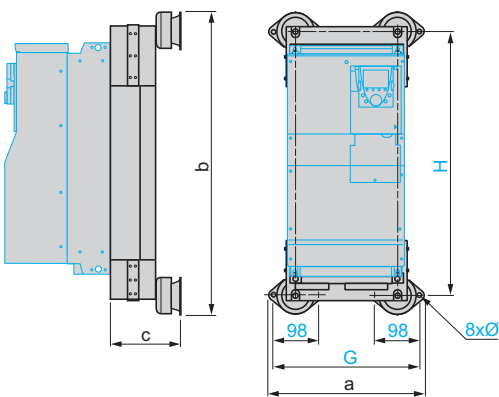

VW3	a	b	c	Ø	G	H
A9 626	320	588	140	9	298	502.5
A9 627	320	716	140	9	298	631
A9 628	400	810	180	9	388	725

#### VW3 A9 642

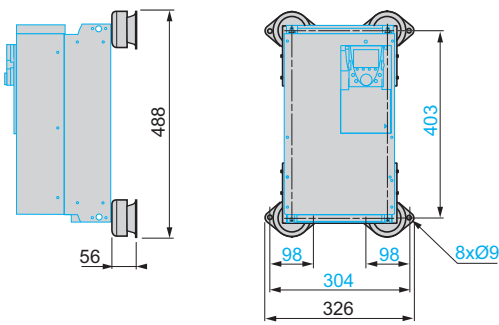

#### VW3 A9 643

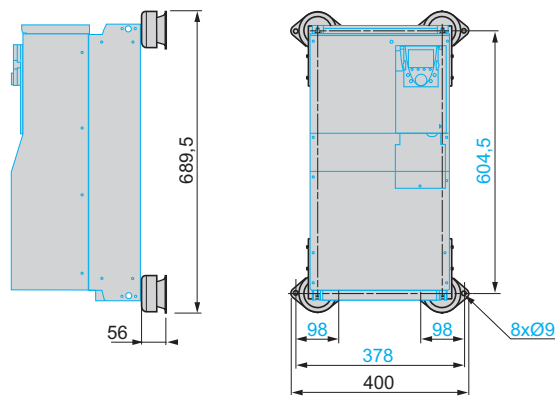

#### Line choke for DNV kit VW3 A9 643 (1)

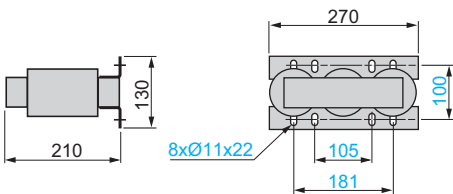

#### EMC input filter for DNV kits VW3 A9 642 and 643 (1)

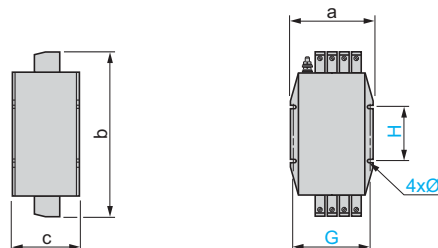

For kit	a	b	c	Ø	G	H
VW3 A9 642	156	237	91	6.6	140	80
VW3 A9 643	171	348	141	6.6	155	115

(1) For mounting the line choke upstream of the variable speed drive, see page 28.

(1) For mounting the EMC filter next to the variable speed drive, see page 28.

**DNV kits (continued)**

VW3 A9 629, 630

**Drill holes and mounting recommendations**

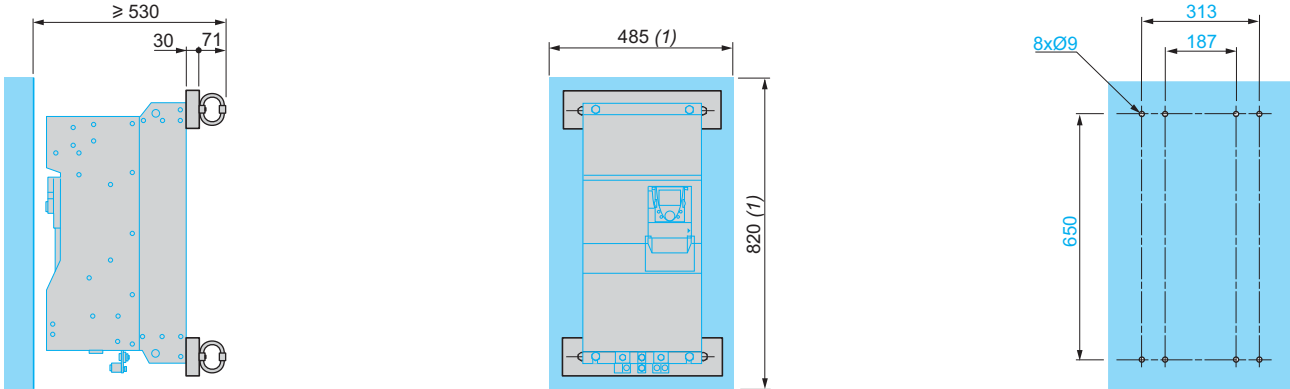

(1) Minimum free area to be left around the drive.

VW3 A9 631, 632

**Drill holes and mounting recommendations**

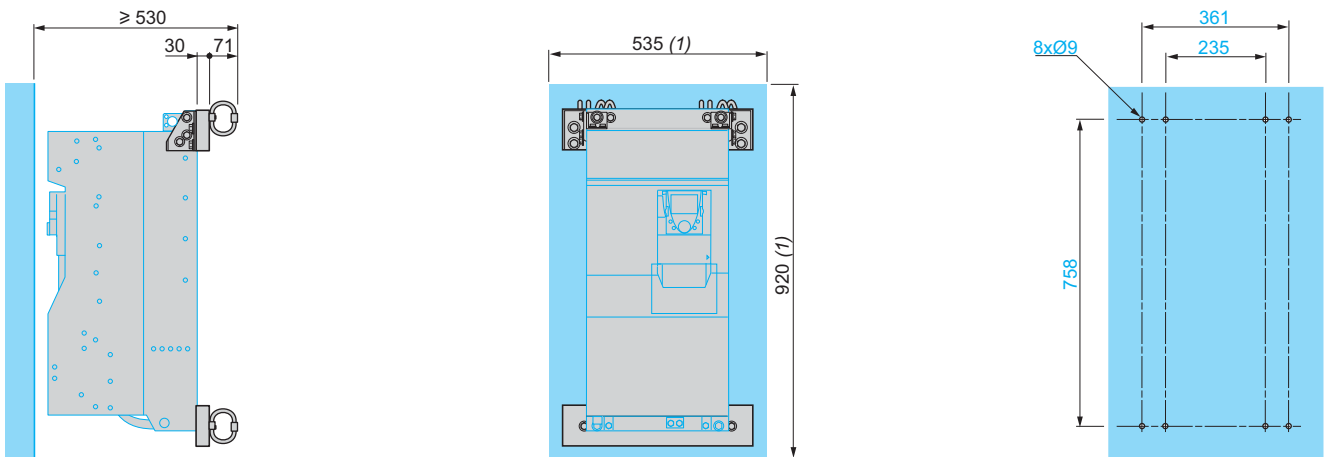

(1) Minimum free area to be left around the drive.

#### DNV kits (continued)

VW3 A9 634...638, 644...647

#### Drill holes and mounting recommendations

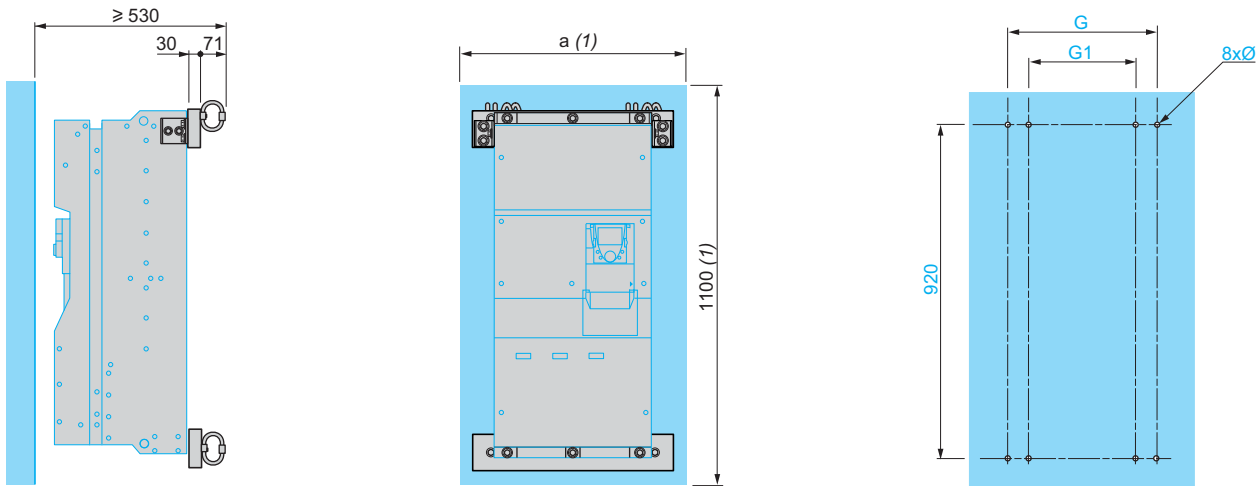

VW3	a	$\varnothing$	G	G1
A9 634, 644, 645	520	9	348	222
A9 635, 636	620	9	413	287
A9 637, 638, 646, 647	770	9	603	477

(1) Minimum free area to be left around the drive.

#### VW3 A9 639, 640

#### Drill holes and mounting recommendations

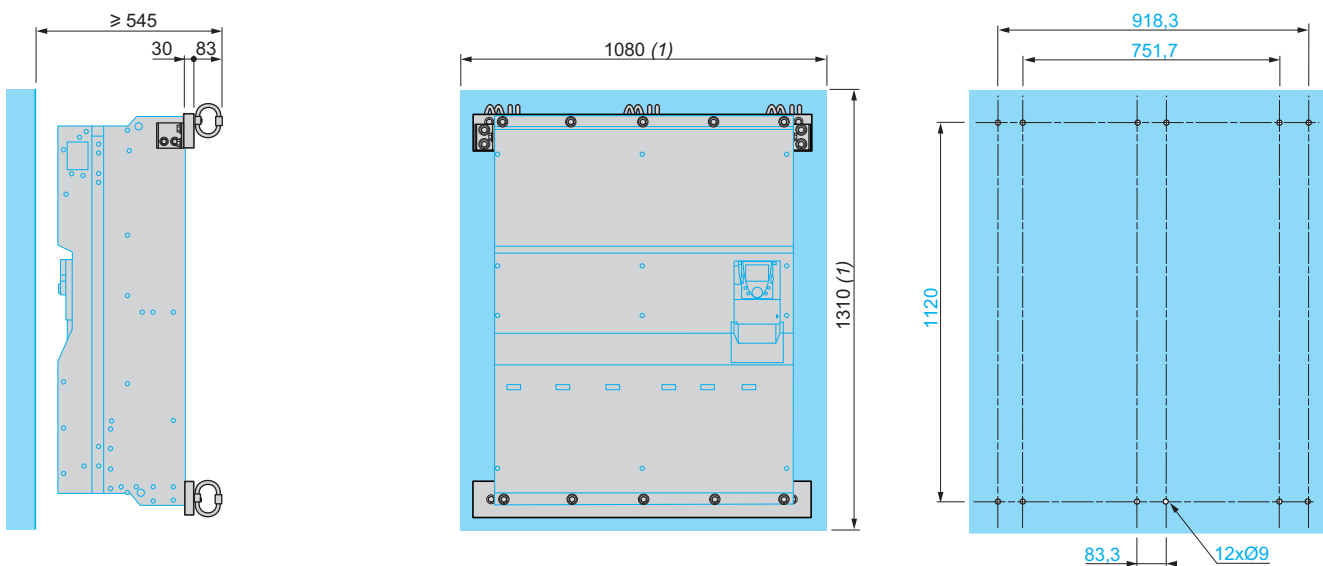

(1) Minimum free area to be left around the drive.

**DNV kits (continued)**

VW3 A9 641, 648, 649

**Drill holes and mounting recommendations**

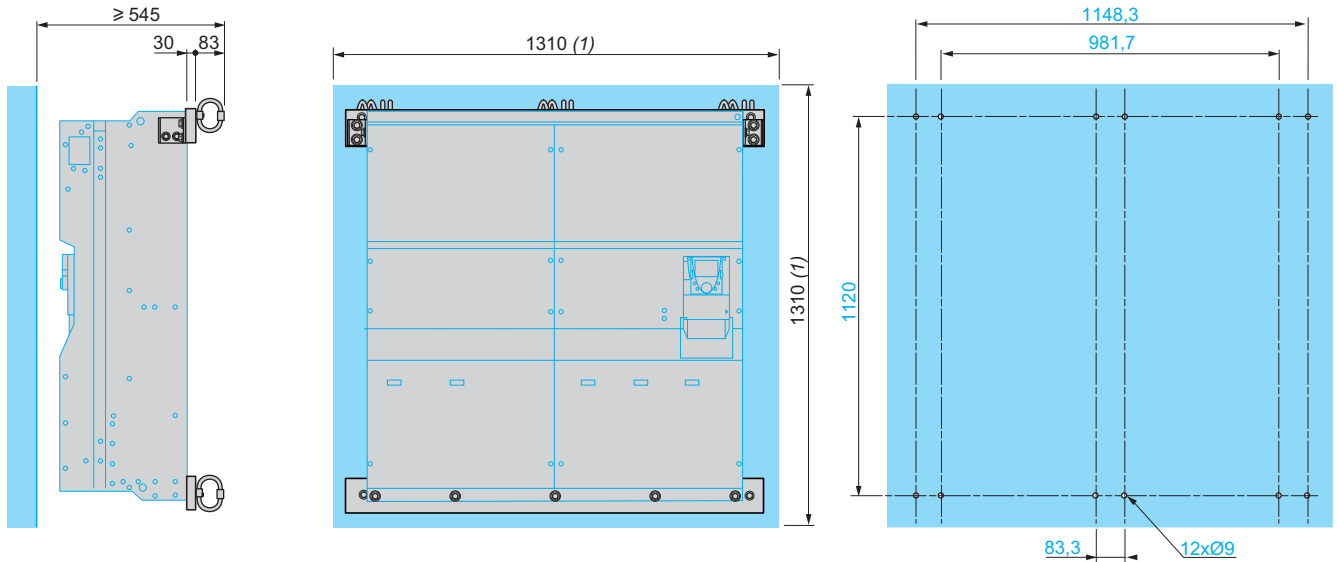

(1) Minimum free area to be left around the drive.

**Kits for UL Type 1 conformity VW3 A9 2●●, IP 21 or IP 31 conformity VW3 A9 1●●**

VW3 A9 201...205, 101...105

VW3 A9 206...208, 217, 106...108, 117

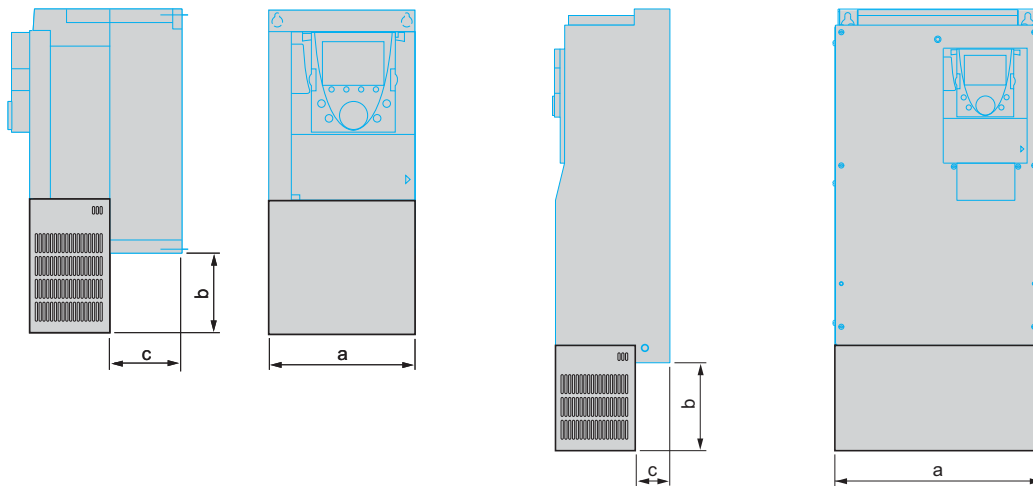

VW3	a	b	c
A9 201	132.6	32	60
A9 202	155	35	70
A9 203	176	32	70
A9 204	211.6	36	90
A9 205	231.6	40	90
A9 101	132.6	115	60
A9 102	155	105	70
A9 103	176	115	70
A9 104	211.6	115	90
A9 105	231.6	130	90

VW3	a	b	c
A9 206	240	60	102
A9 207	240	52	102
A9 217	320	48	102
A9 208	320	136	116
A9 106	240	186	102
A9 107	240	178	102
A9 117	320	180	102
A9 108	320	180	116



**Kits for UL Type 1 conformity VW3 A9 2●●, IP 21 or IP 31 conformity VW3 A9 1●● (continued)**

VW3 A9 209...214,  
VW3 A9 109...116

VW3 A9 209...213,  
VW3 A9 109...113, 115

VW3 A9 214, 114  
(with braking unit)

VW3 A9 116

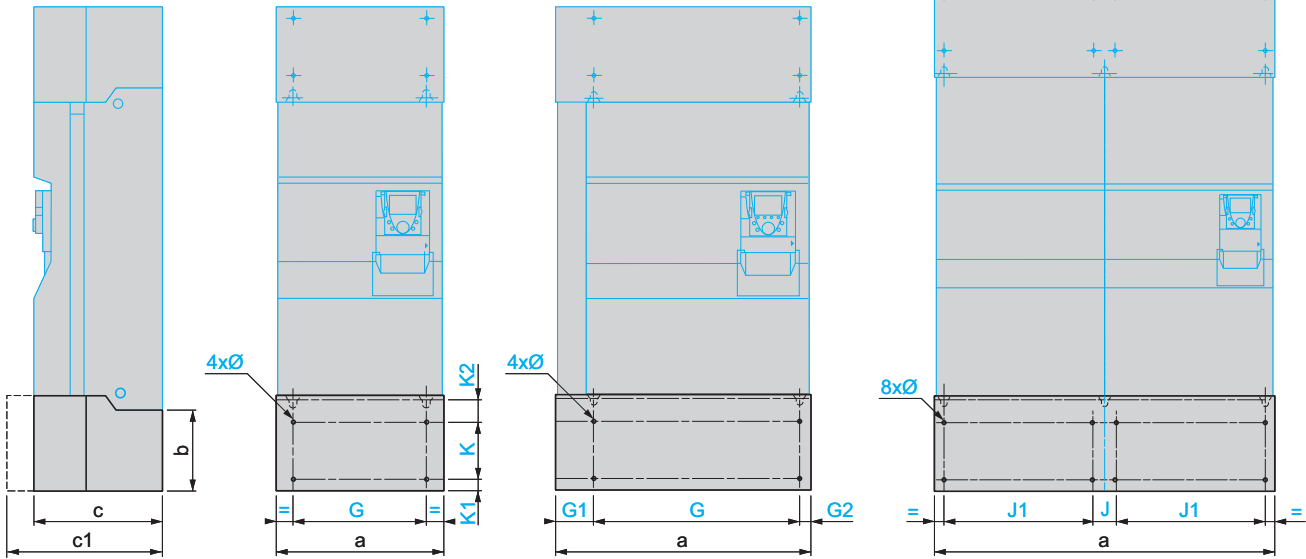

VW3	a	b	c	c1	G	G1	G2	K	K1	K2	Ø	J	J1
A9 209	334	220	377	-	250	-	-	95	65	75	11.5	-	-
A9 210	374	300	377	-	298	-	-	172	65	75	11.5	-	-
A9 211	345	315	377	-	285	-	-	250	65	75	11.5	-	-
A9 212	445	375	377	-	350	-	-	250	65	75	11.5	-	-
A9 213	600	375	377	-	540	-	-	250	65	75	11.5	-	-
A9 214	670	375	377	-	540	102	27	250	65	75	11.5	-	-
A9 109	334	220	377	-	250	-	-	95	65	75	11.5	-	-
A9 110	374	300	377	-	298	-	-	172	65	75	11.5	-	-
A9 111	345	315	377	-	285	-	-	250	65	75	11.5	-	-
A9 112	445	375	377	-	350	-	-	250	65	75	11.5	-	-
A9 113	600	375	377	-	540	-	-	250	65	75	11.5	-	-
A9 114	670	375	377	-	540	102	27	250	65	75	11.5	-	-
A9 115	895	475	-	477	835	-	-	350	65	75	11.5	-	-
A9 116	1125	475	-	477	-	-	-	350	65	75	11.5	70	495

**Kits for flush-mounting in a dust and damp proof enclosure**

Installing the drive using the flush-mounting kit

Side view

Side view

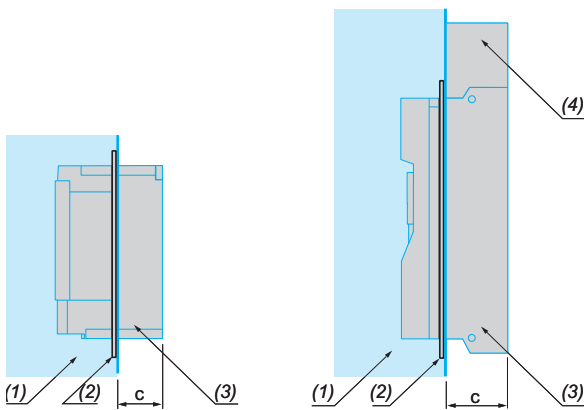

For ATV 61H drives	c	Kit VW3
075M3, U15M3, 075N4...U22N4	60	A9 501
U22M3...U55M3, U30N4...U75N4	70	A9 502, 503
U75M3, D11M3X, D15M3X, D11N4... D18N4	90	A9 504, 505
D18M3X...D45M3X D22N4...D75N4, U30Y...D30Y	105	A9 506...509
D55M3X, D75M3X D55M3XD, D75M3XD, D90N4, C11N4, D90N4D, C11N4D	150	VW3 A9 510
D90M3X, D90M3XD, C13N4...C31N4, C13N4D...C31N4D, C11Y...C40Y	250	VW3 A9 511...515

- (1) Dust and damp proof enclosure.
- (2) Kit for flush-mounting in a dust and damp proof enclosure.
- (3) Drive power section outside the enclosure.
- (4) DC choke for ATV 61HD55M3X...HD90M3X and  
ATV 61HD90N4...HC31N4 drives.  
Transformer for powering the fan for ATV 61HC11Y...HC40Y drives.

**Kits for flush-mounting in a dust and damp proof enclosure (continued)**

Installing the drive using the flush-mounting kit (continued)

VW3 A9 501...505

Cut-outs and drill holes

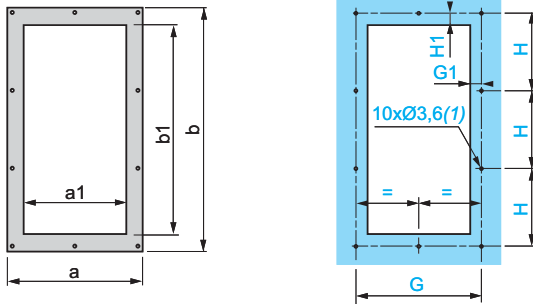

VW3 A9 506

Cut-outs and drill holes

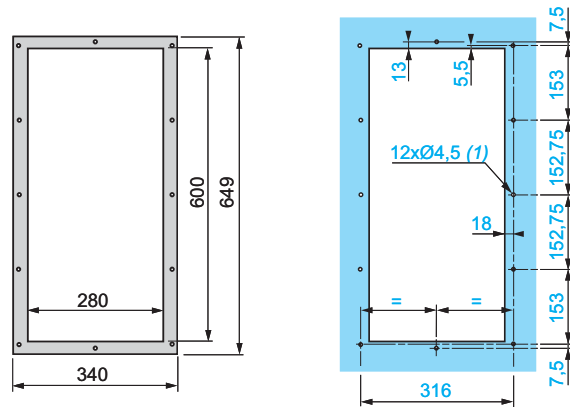

VW3	a	a1	b	b1	G	G1	H	H1
A9 501	222	170	397	351	205	17.5	127	15
A9 502	250	198	429.5	384.5	233	17.5	137.5	14
A9 503	267	215	465	419	250	17.5	149.5	14.5
A9 504	302	250	481.5	438	285	17.5	155	13
A9 505	324.5	270	584.5	537.5	305	17.5	189.5	15.5

(1) Ø 3.6 hole for M4 self-tapping screw.

(1) Ø 4.5 hole for M5 self-tapping screw.

VW3 A9 507

Cut-outs and drill holes

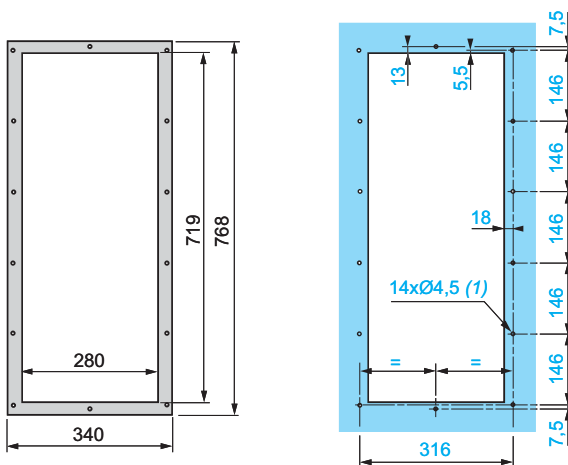

VW3 A9 508

Cut-outs and drill holes

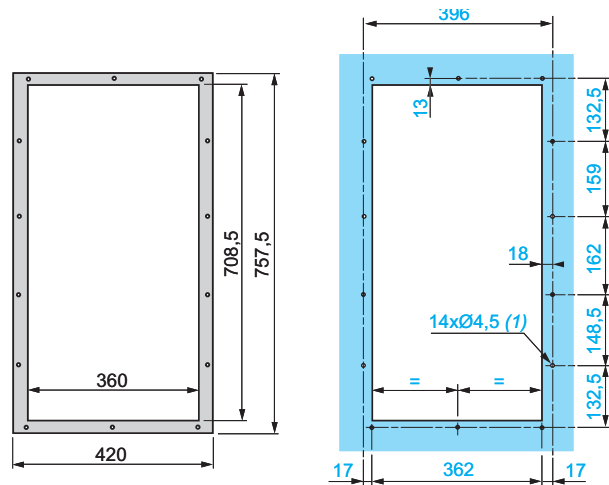

(1) Ø 4.5 hole for M5 self-tapping screw.

(1) Ø 4.5 hole for M5 self-tapping screw.

**Kits for flush-mounting in a dust and damp proof enclosure (continued)**

VW3 A9 509

Cut-outs and drill holes

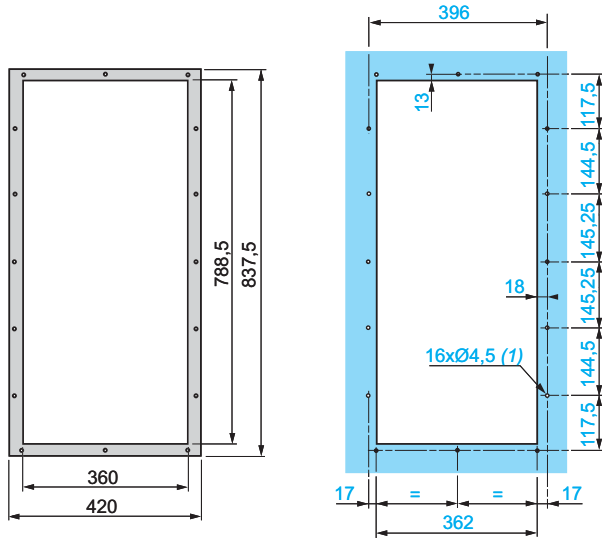

(1) Ø 4.5 hole for M5 self-tapping screw.

VW3 A9 510, 511

Cut-outs and drill holes without DC choke

Cut-outs and drill holes with DC choke

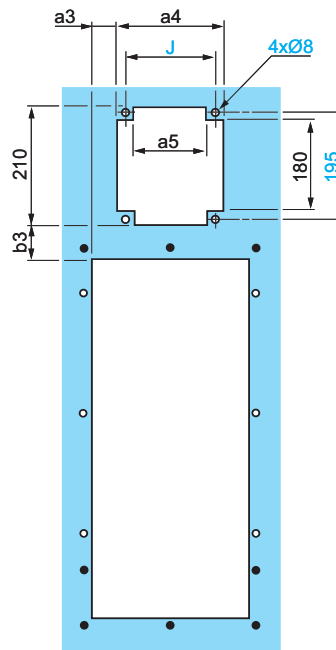
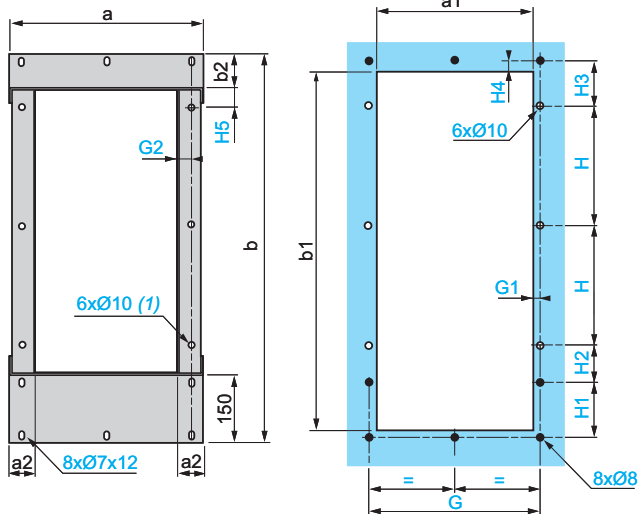

VW3	a	a1	a2	b	b1	b2	G	G1
A9 510	420	340	55	850	790	80	370	15
A9 511	440	360	45	885	845	66	396	18
VW3	G2	H	H1	H2	H3	H4	H5	
A9 510	30	260	120	80	100	15	35	
A9 511	23	310	70	91.5	83.5	10	27.5	

VW3	a3	a4	a5	b3	J
A9 510	82.5	180	120	45	150
A9 511	87.5	190	130	35	160

(1) For fixing using an M8 minimum screw.

**Kits for flush-mounting in a dust and damp proof enclosure (continued)**

VW3 A9 512, 513

Cut-outs and drill holes  
without DC choke

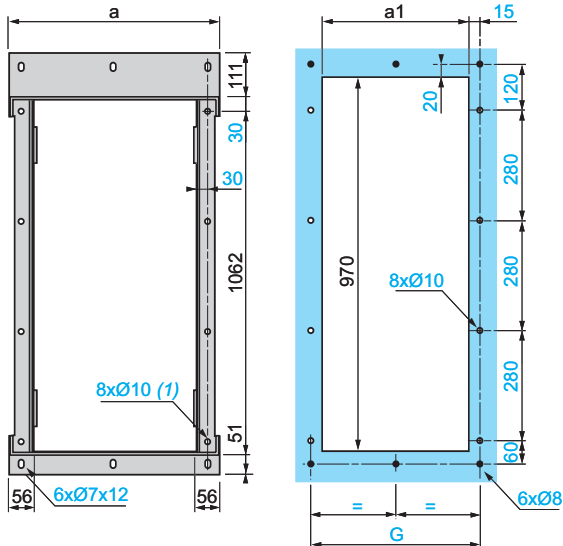

VW3 A9 512

Cut-outs and drill holes with DC choke  
or transformer for fan

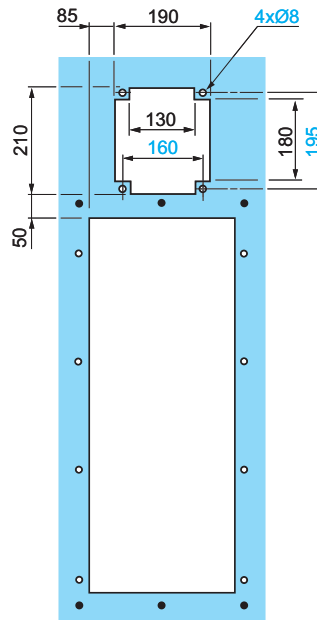

VW3 A9 513

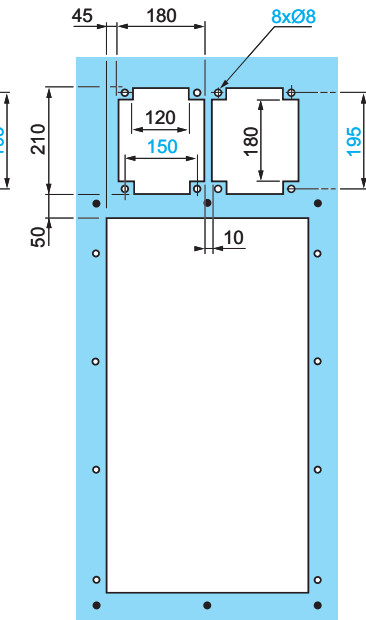

VW3	a	a1	G
A9 512	442	360	390
A9 513	542	460	490

(1) For fixing using an M8 minimum screw.

**VW3 A9 514 (without braking unit), VW3 A9 515 (with braking unit)**

Cut-outs and drill holes  
without DC choke

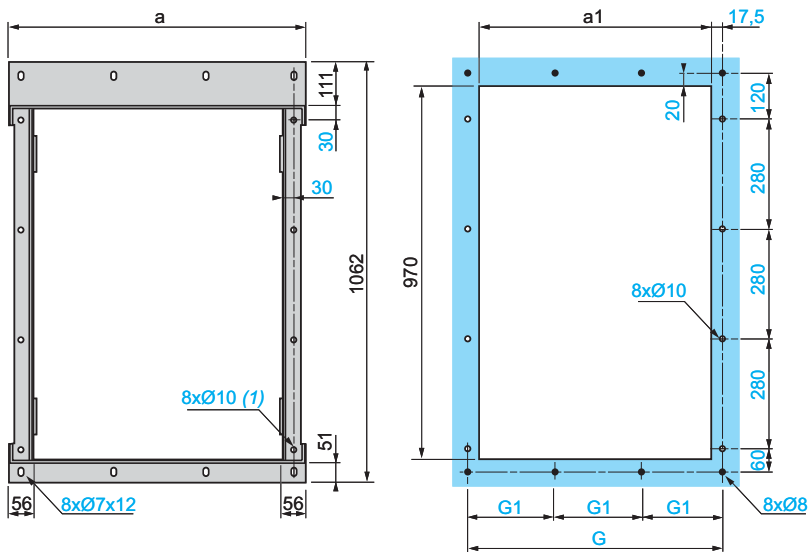

Cut-outs and drill holes with DC choke  
or transformer for fan

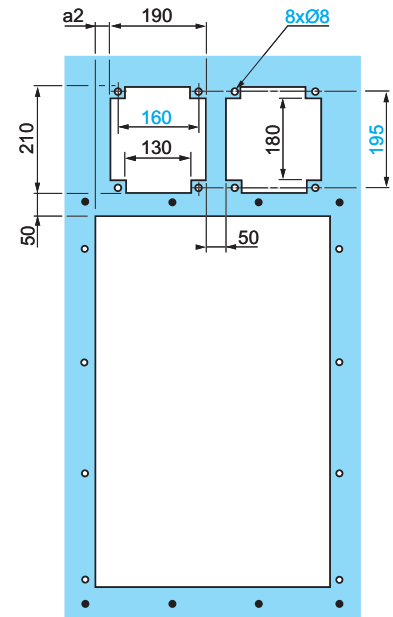

VW3	a	a1	G	G1
A9 514	697	610	645	215
A9 515	772	685	720	240

VW3	a2
A9 514	90
A9 515	165

(1) For fixing using an M8 minimum screw.

#### Remote graphic display terminal

IP 54 kit VW3 A1 102

IP65 door VW3 A1 103

#### Cut-outs and drill holes

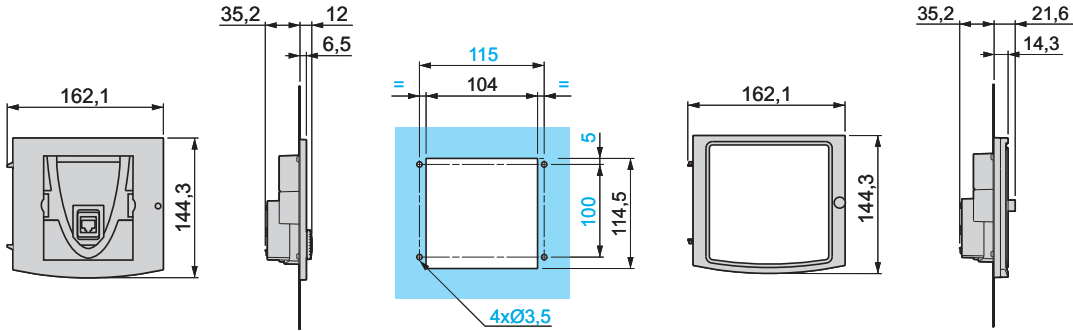

#### Braking units VW3 A7 101 (1), VW3 A7 102...104

VW3 A7 102...104

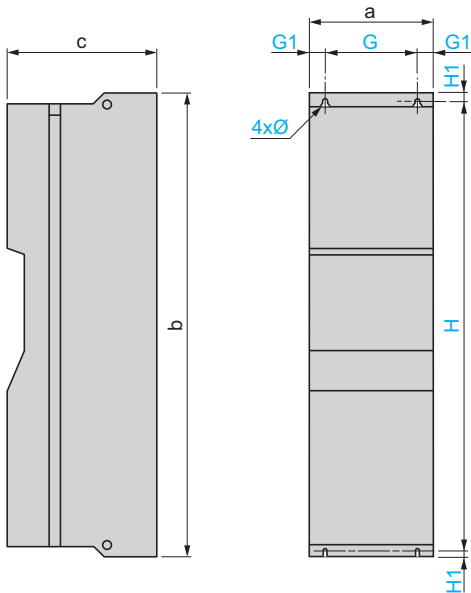

VW3	a	b	c	G	G1	H	H1	Ø
A7 101 (1)	75	950	377	-	-	-	-	-
A7 102...104	310	1150	377	265	22.5	1120	15	11.5

(1) Braking unit VW3 A7 101 can only be mounted on the left side of the drive, see page 181 and 183.

#### Braking resistors

VW3 A7 701...703

#### Mounting recommendations

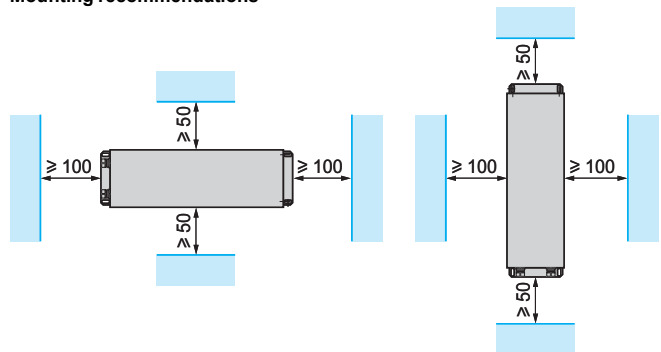
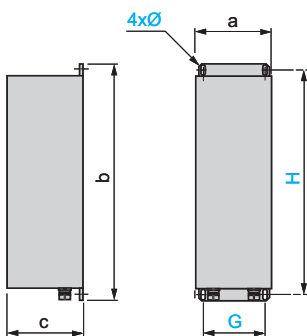

VW3	a	b	c	G	H	Ø
A7 701	95	293	95	70	275	6 x 12
A7 702	95	293	95	70	375	6 x 12
A7 703	140	393	120	120	375	6 x 12

### Braking resistors (continued)

VW3 A7 704...709

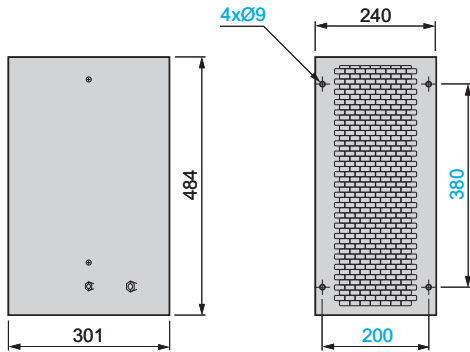

#### Mounting recommendations

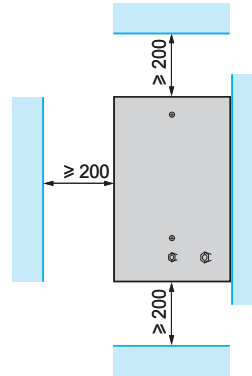

VW3 A7 710...712, 715...718 (1)

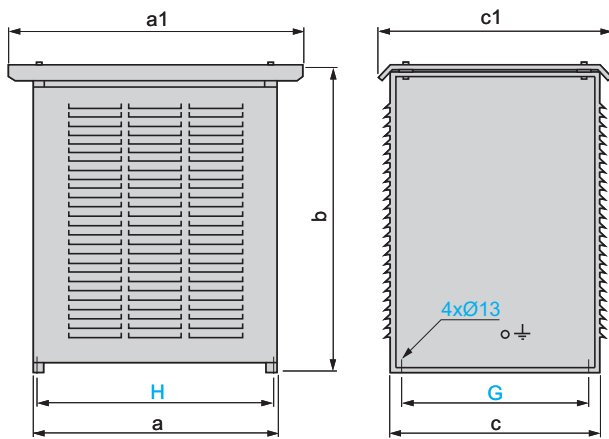

#### Mounting recommendations

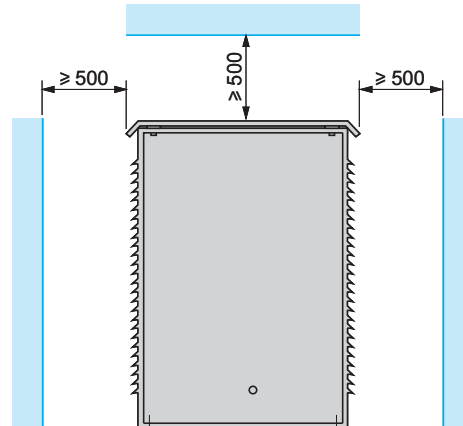

VW3	a	a1	b	c	c1	G	H
A7 710	860	1040	690	480	560	400	832
A7 711	960	1140	1150	380	460	300	932
A7 712	860	1040	1150	540	620	460	832
A7 715	960	1140	1150	540	620	460	932
A7 716 (1)	960	1140	1150	740	820	660	932
A7 717 (1) (2)	960	1140	1150	540	620	460	932
A7 718 (1) (2)	960	1140	1150	740	820	660	932

(1) For mounting in series or parallel, a space of 300 mm must be left between each resistor.

(2) The dimension is given for 1 component. References VW3 A7 717, 718 comprise two components; all components must be taken into account to determine the overall dimensions. A space of 300 mm must be left between each component.

**Braking resistors (continued)**

VW3 A7 713, 714

**Mounting recommendations**

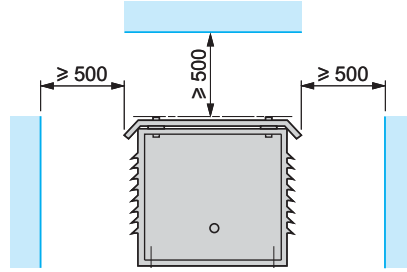
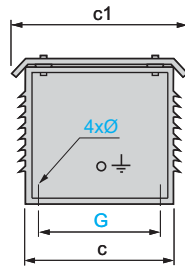
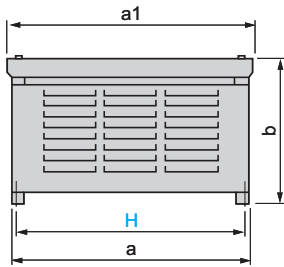

VW3	a	a1	b	c	c1	G	H
A7 713	760	790	440	480	540	400	732
A7 714	960	990	440	480	540	400	932

VW3 A7 805, 806, 814, 816 (1)

**Mounting recommendations**

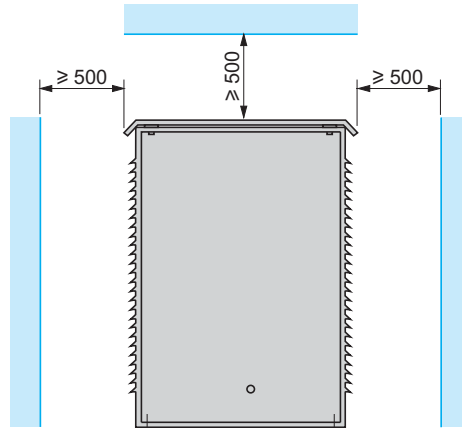
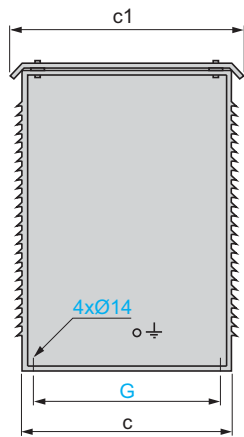
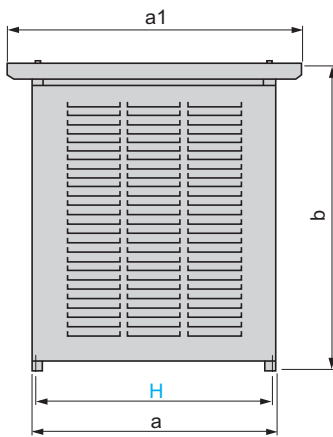

VW3	a	a1	b	c	c1	G	H
A7 805 (1)	860	1040	1150	540	620	460	832
A7 806 (1)	860	1040	1150	740	820	660	832
A7 814 (1) (2)	960	1140	1150	540	620	460	932
A7 816 (1) (2)	960	1140	1150	740	820	660	932

(1) For mounting in series or parallel, a space of 300 mm must be left between each resistor.

(2) The dimension is given for 1 component. Reference VW3 A7 814 comprises 2 components and reference VW3 A7 816 comprises 3 components; all components must be taken into account to determine the overall dimensions. A space of 300 mm must be left between each component.

#### DC chokes

##### VW3 A4 501...510

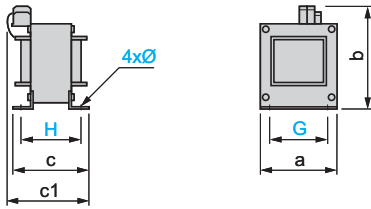

VW3	a	b	c	c1	G	H	Ø
A4 501	60	103	60	95	50	51	3.5
A4 502	60	103	77	118	50	68	3.5
A4 503	96	134	80	115	80	65	5.5
A4 504	96	134	79	115	80	64	5.5
A4 505	96	134	85	120	80	70	5.5
A4 506	96	134	89	120	80	74	5.5
A4 507	96	134	99	130	80	84	5.5
A4 508	108	142	112	145	90	97	5.5
A4 509	96	134	89	120	80	74	5.5
A4 510	126	171	120	170	105	103	7

##### VW3 A4 511, 512

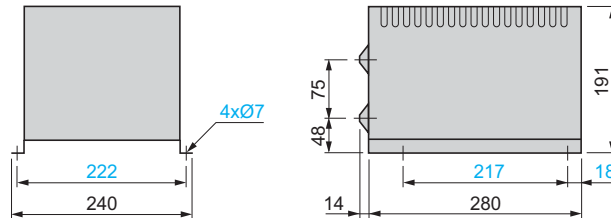

#### Line chokes

##### VW3 A58501, A58502

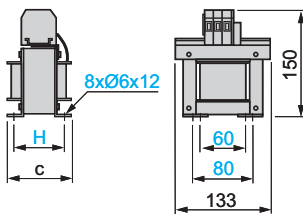

VW3	c	H
A58501	95	65
A58502	105	77

##### VW3 A4 551...555

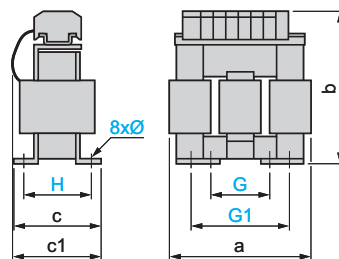

VW3	a	b	c	c1	G	G1	H	Ø
A4 551	100	135	55	60	40	60	42	6 x 9
A4 552, A4 553	130	155	85	90	60	80.5	62	6 x 12
A4 554	155	170	115	135	75	107	90	6 x 12
A4 555	180	210	125	165	85	122	105	6 x 12

##### VW3 A4 556

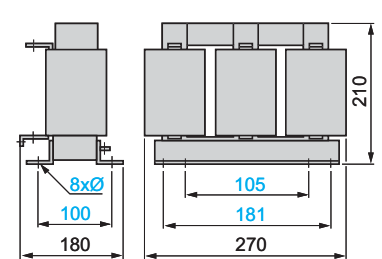

VW3	Ø
A4 556	11 x 22

##### VW3 A4 557

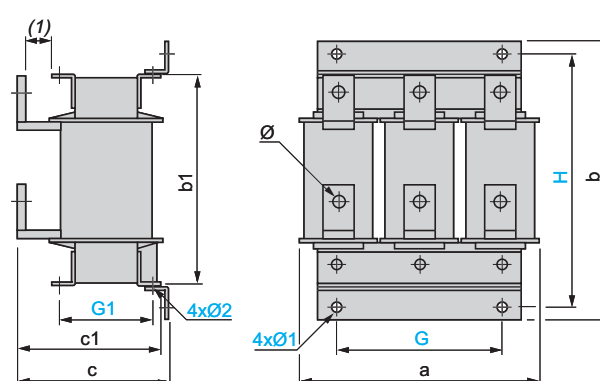
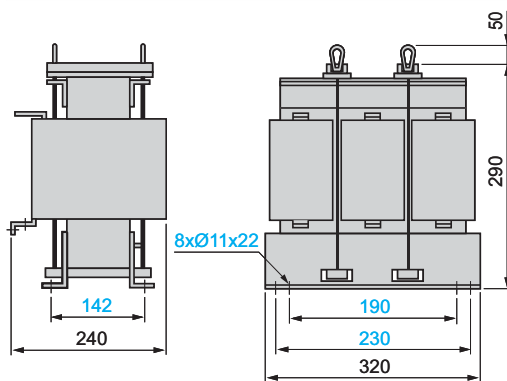

VW3	a	b	b1	c	c1	G	G1	H	Ø	Ø1	Ø2
A4 558, 570	280	305	240	210	200	200	125	275	9	9	9
A4 559	280	330	260	210	200	200	125	300	11	9	9
A4 560, 561, 568	320	380	300	210	200	225	150	350	11	9	9
A4 564	320	380	300	250	230	225	150	350	13	11	11
A4 565	385	440	340	275	250	300	125	400	2 x Ø13	13.5	13.5
A4 569	320	380	300	250	230	225	150	350	13	11	11
A4 571	385	440	340	265	245	300	150	400	13	13	13
A4 572	385	440	340	305	245	300	150	400	13	13	13

(1) 25 mm minimum.



**Passive filters VW3 A4 601...609, 621...627, 641...648, 661...666**

Mounting recommendations (1)



**VW3 A4 601...604, 621, 622, 641...644, 661...663**

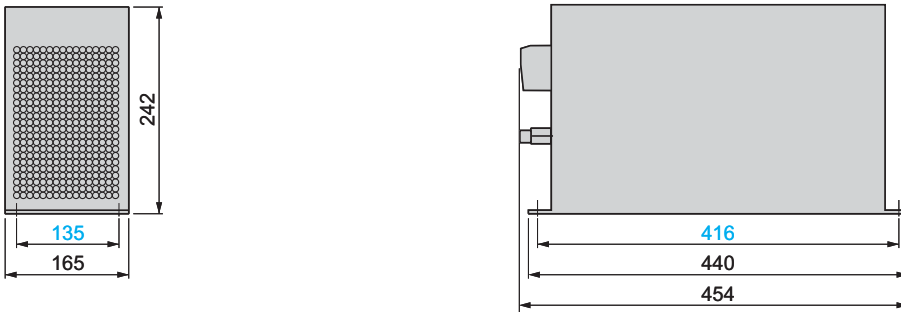

**VW3 A4 605...609, 623...627, 645...648, 664...666**

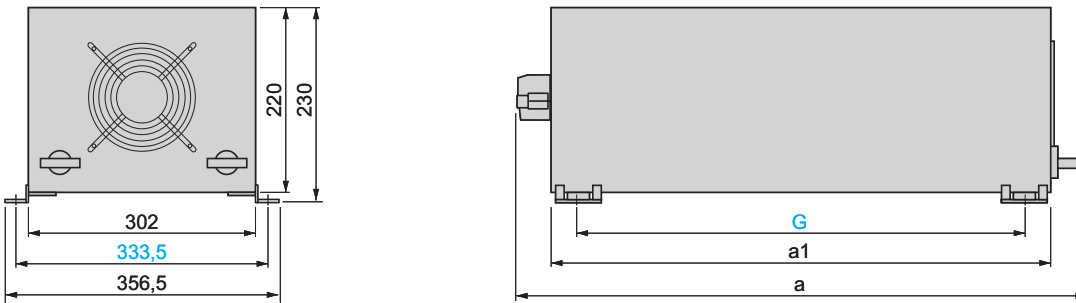

VW3	a	a1	G
A4 605, 606, 623...625, 645, 646, 664, 665	698	600	532.5
A4 607...609, 626, 627, 647, 648, 666	938	840	772.5

(1) Vertical mounting only

**Passive filters VW3 A4 610...613, 619, 628...633, 639, 649...651, 656, 657, 667...671, 676, 677**

Mounting recommendations (1)

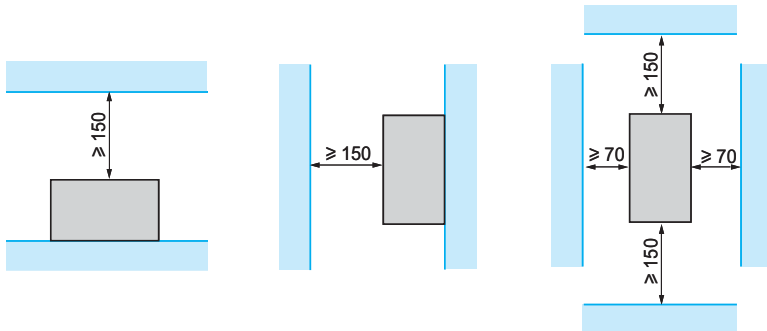

**VW3 A4 610...613, 619, 628...632, 639, 649...651, 656, 657, 667...670, 676, 677**

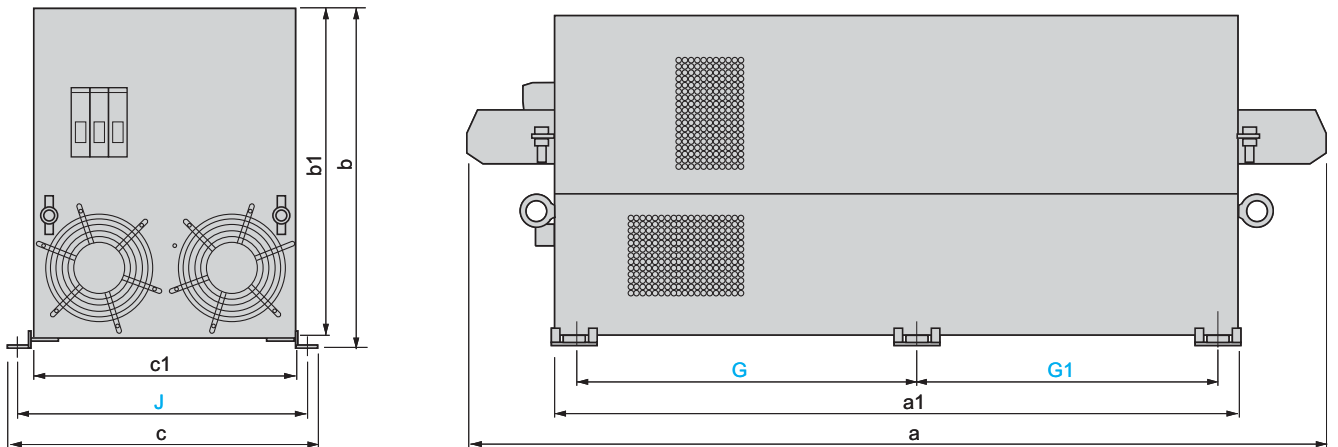

VW3	a	a1	b	b1	c	c1	G	G1	J
A4 610, 611, 628, 629, 649, 667, 668	1060	830	400	390	393	345	395	377	370
A4 612, 619, 630, 631, 650, 656, 657, 669	1160	900	419	409	454	406	430	412	430
A4 613, 632, 639, 651, 670, 676, 677	1330	1070	419	409	454	406	515	497	430

**VW3 A4 633, 671**

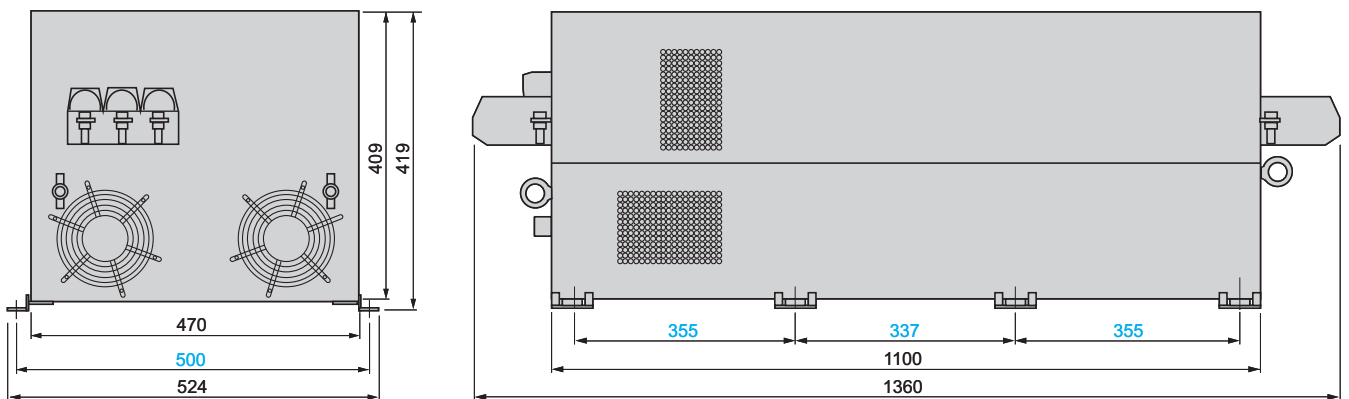

(1) Horizontal or vertical mounting

**Additional EMC input filters**

**VW3 A4 401...404**

**VW3 A4 405, 409**

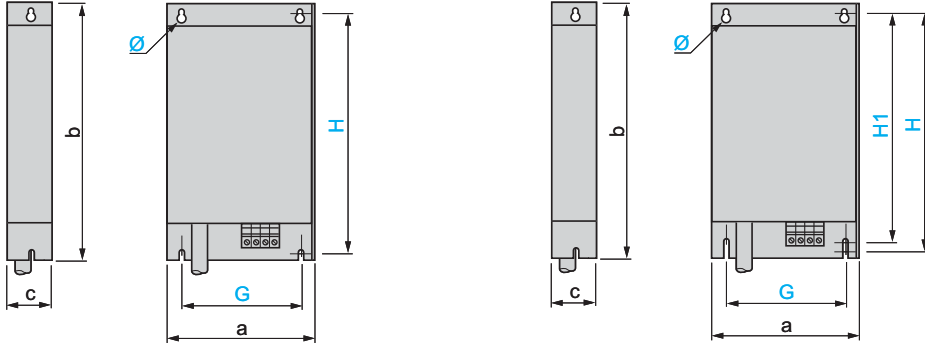

VW3	a	b	c	G	H	H1	Ø
A4 401	130	290	40	105	275	–	4.5
A4 402	155	324	50	130	309	–	4.5
A4 403	175	370	60	150	355	–	6.5
A4 404	210	380	60	190	365	–	6.5
A4 405	230	498.5	62	190	479.5	460	6.5
A4 409	230	498.5	62	190	479.5	460	6.5

**VW3 A4 406...408**

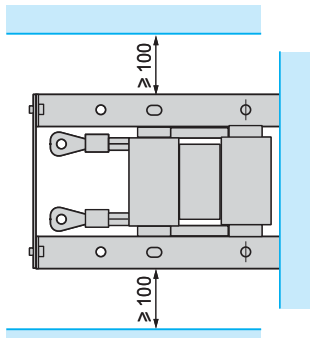

VW3	a	b	c	G	H	J	Ø
A4 406	240	522	79	200	502.5	40	9
A4 407	240	650	79	200	631	40	9
A4 408	320	750	119	280	725	80	9

**Mounting the filter under the drive**

**Mounting the filter next to the drive**

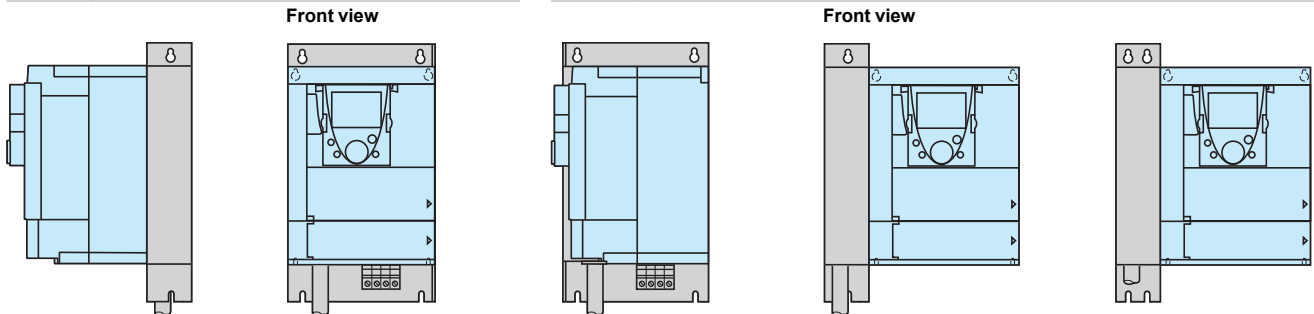

**Additional EMC input filters (continued)**

**VW3 A4 410...413**

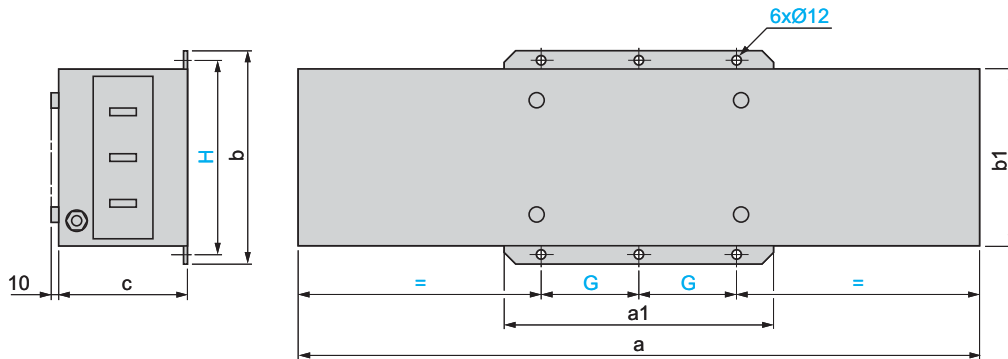

VW3	a	a1	b	b1	c	G	H
A4 410	800	302	261	219	139	120	235
A4 411	800	302	261	219	139	120	235
A4 412	900	352	281	239	174	145	255
A4 413	1000	401	301	259	164	170	275

**IP 30 protection kits for filters VW3 A4 410...413**

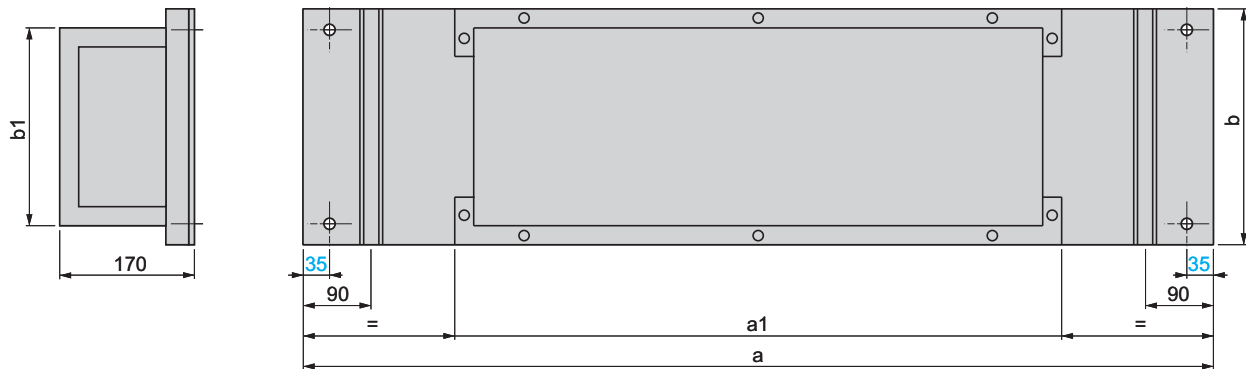

VW3	a	a1	b	b1
A9 601	1200	800	310	270
A9 602	1400	1000	350	310

**Motor chokes (1)**

VW3 A5 101, 102

**Mounting recommendations (2)**

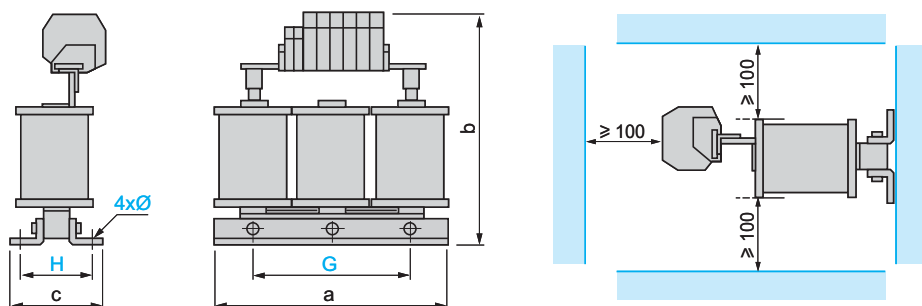

VW3	a	b	c	G	H	Ø
A5 101	190	210	90	170	45	8 x 12
A5 102	190	235	120	170	48	8 x 12

**VW3 A5 103**

**Mounting recommendations (2)**

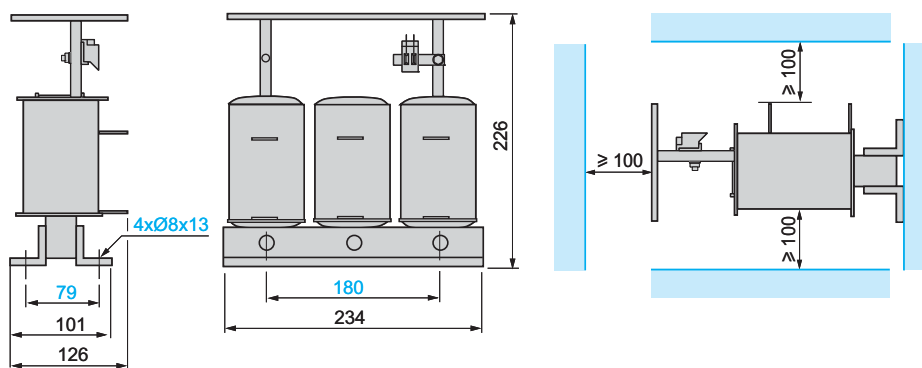

(1) It is absolutely essential that the motor chokes are mounted on a metal support (grille, frame, etc.)

(2) Because of the magnetic field and/or the heat dissipation, it is essential to follow the mounting recommendations provided.

**Motor chokes (continued) (1)**

**VW3 A5 104, 105 (2)**

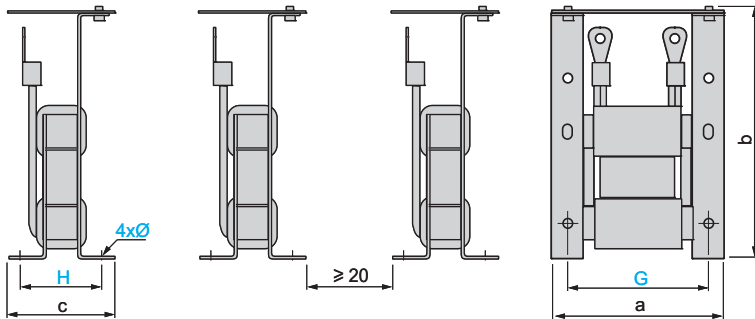

VW3	a	b	c	G	H	Ø
A5 104	170	250	100	150	75	9 x 13
A5 105	210	250	110	175	75	9 x 13

**Mounting recommendations (3)**

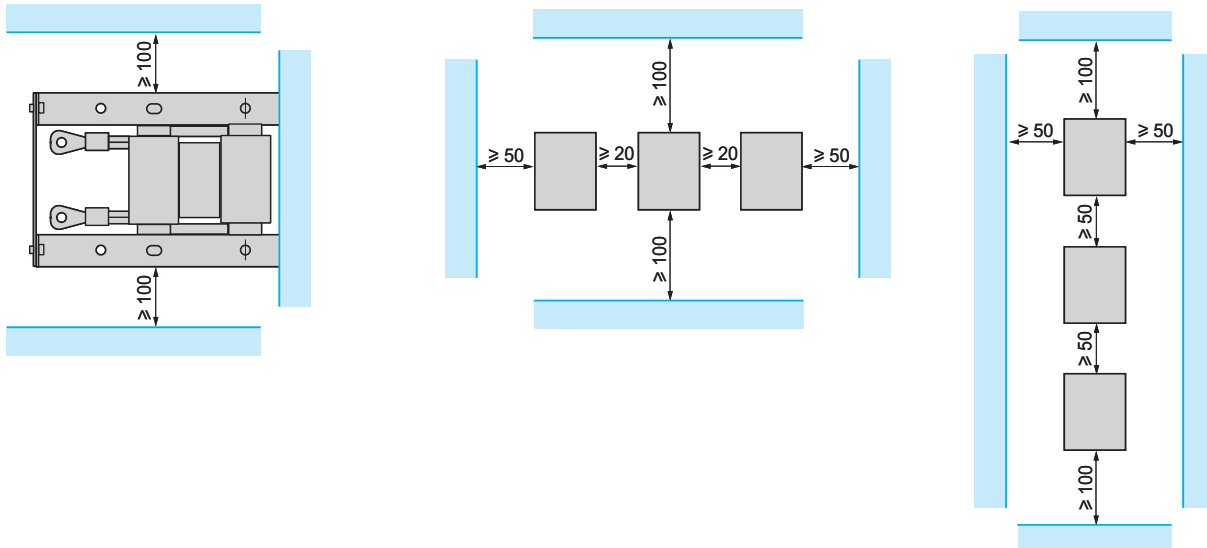

(1) It is absolutely essential that the motor chokes are mounted on a metal support (grille, frame, etc.)

(2) References VW3 A5 104 and 105 comprise 3 components.

(3) Because of the magnetic field and/or the heat dissipation, it is essential to follow the mounting recommendations provided.

**Motor chokes (continued) (1)**

**VW3 A5 106...108 (2)**

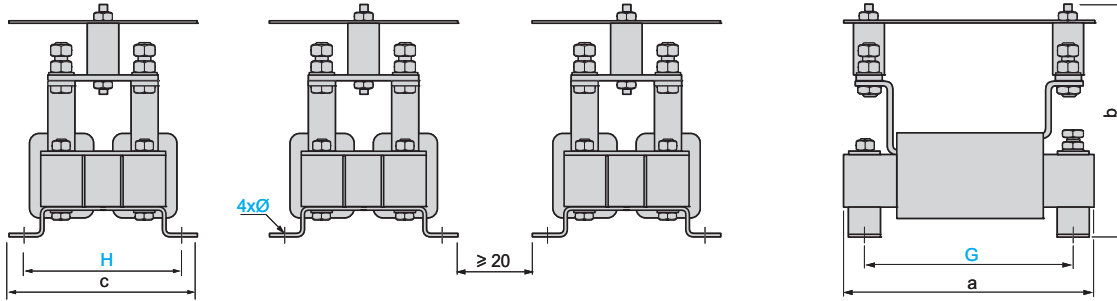

VW3	a	b	c	G	H	Ø
A5 106	245	250	200	225	175	9 x 13
A5 107	320	250	220	275	200	9 x 13
A5 108	370	250	230	325	200	9 x 13

**Mounting recommendations (3)**

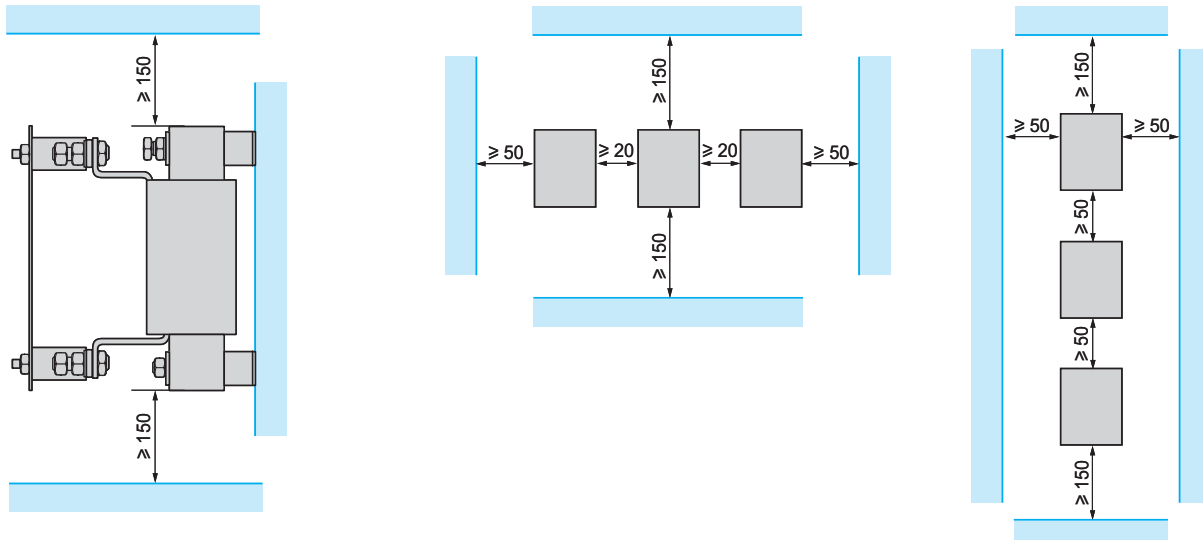

(1) It is absolutely essential that the motor chokes are mounted on a metal support (grille, frame, etc.)

(2) References VW3 A5 106...108 comprise 3 components.

(3) Because of the magnetic field and/or the heat dissipation, it is essential to follow the mounting recommendations provided.

**IP 20 protection kits for chokes VW3 A5 104...108**

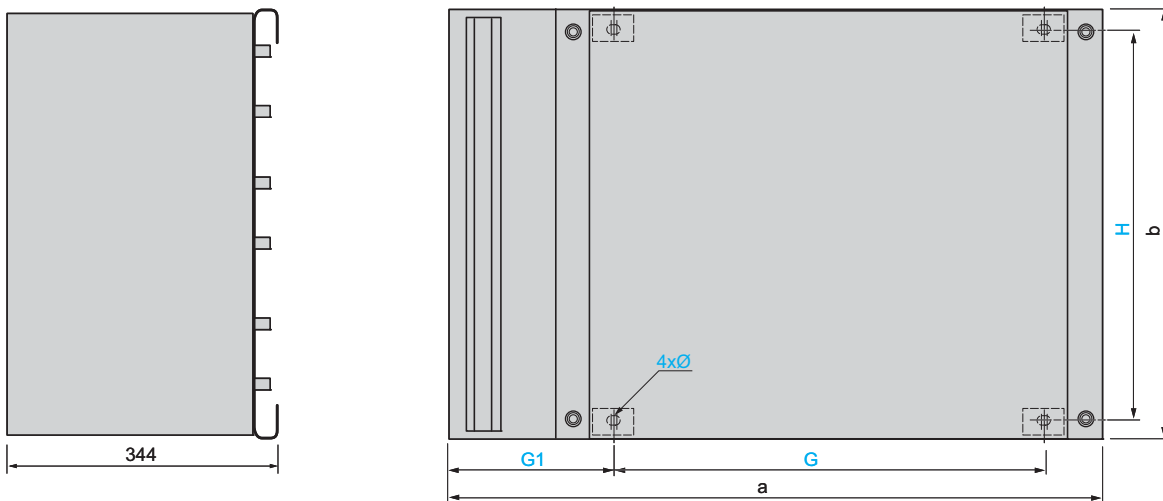

VW3	a	b	G	G1	H	Ø
A9 612	780	580	530	190	526	10 x 15
A9 613	1180	780	800	200	726	10 x 15

#### Sinus filters (1)

#### VW3 A5 201...206

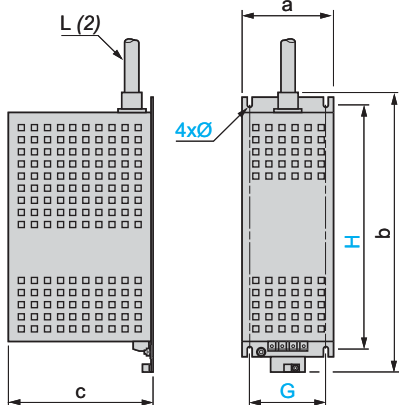

VW3	a	b	c	G	H	Ø	L (2)
A5 201	120	335	160	100	280	6.6	700
A5 202	120	405	190	100	350	6.6	900
A5 203	150	470	240	120	380	6.6	900
A5 204	210	650	280	160	530	8.6	1500
A5 205	250	780	360	200	650	11	1600
A5 206	310	1060	375	220	880	11	2700

#### VW3 A5 207

#### Mounting recommendations

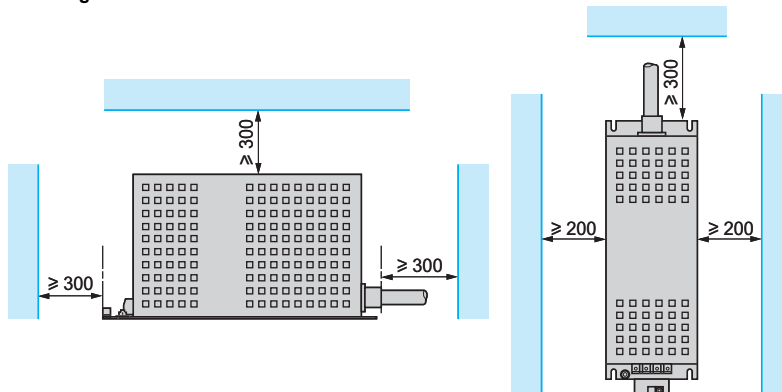

#### Mounting recommendations

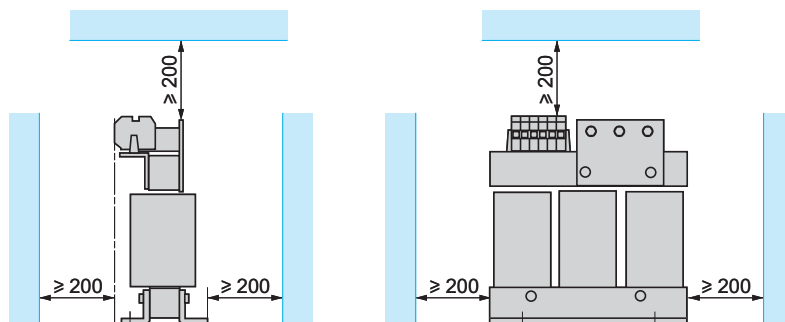
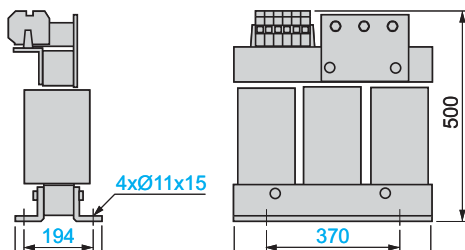

#### VW3 A5 208...211

#### Mounting recommendations

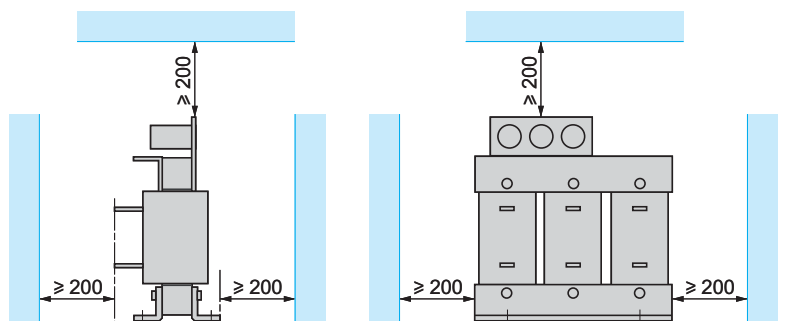
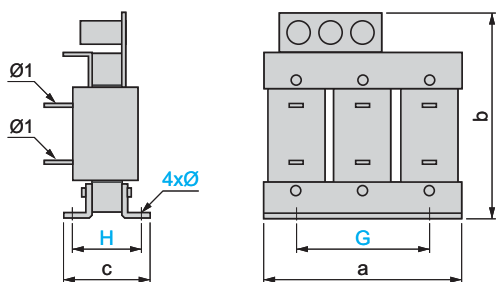

VW3	a	b	c	G	H	Ø	Ø1
A5 208	420	500	345	370	231	11 x 15	11
A5 209	480	600	340	430	238	13 x 18	11
A5 210	480	710	370	430	258	13 x 18	14
A5 211	620	930	500	525	352	13 x 22	4 x Ø11

(1) Sinus filters emit considerable heat and must not be placed underneath the drive.

(2) Length of the cable integrated in the sinus filter.



**"Power Removal" safety function**

The Altivar 61 drive integrates the "Power Removal" safety function which prohibits unintended equipment operation. The motor no longer produces torque.

This safety function:

- Complies with the standard for safety of machinery EN 954-1, category 3
- Complies with operational safety standard IEC/EN 61508, SIL2 capability (safety control-signalling applied to processes and systems)

The SIL (Safety Integrity Level) capability depends on the connection scheme for the drive and for the safety function. Failure to observe the setup recommendations could inhibit the SIL capability of the "Power Removal" safety function.

- Complies with draft product standard IEC/EN 61800-5-2 for the two stop functions:

- Safe Torque Off ("STO"): response time  $\leq 100$  ms
- Safe Stop 1 ("SS1")

The "Power Removal" safety function has a redundant electronic architecture <sup>(1)</sup> which is monitored continuously by a diagnostics function.

This level SIL2 and category 3 safety function is certified as conforming to these standards by the INERIS certification body under a program of voluntary certification.

**Categories relating to safety according to EN 954-1**

Category	Basic safety principle	Control system requirements	Behaviour in the event of a fault
<b>B</b>	Selection of components that conform to relevant standards	Control in accordance with good engineering practice	Possible loss of safety function
<b>1</b>	Selection of components and safety principles	Use of tried and tested components and proven safety principles	Possible loss of the safety function with a lower probability than in <b>B</b>
<b>2</b>	Selection of components and safety principles	Cyclic testing. The test intervals must be appropriate to both the machine and its application	Fault detected on each test
<b>3</b>	Structure of the safety circuits	A single fault must not result in loss of the safety function. This single fault must be detected, if reasonably practicable	Safety function ensured, except in the event of an accumulation of faults
<b>4</b>	Structure of the safety circuits	A single fault must not result in loss of the safety function. This fault must be detected when or before the safety function is next invoked. An accumulation of faults must not result in loss of the safety function.	Safety function always ensured

The machinery manufacturer is responsible for selecting the safety category. The category depends of the level of risk factors given in standard EN 954-1.

**Note:** The Altivar 61 variable speed drive can be used up to category 3.

**Safety Integrity Levels (SIL) according to standard IEC/EN 61508**

SIL1 according to standard IEC/EN 61508 is comparable with category 1 according to EN 954-1 (SIL1: mean probability of undetected hazardous failure per hour between  $10^{-5}$  and  $10^{-6}$ ).

SIL2 according to standard IEC/EN 61508 is comparable with category 3 according to EN 954-1 (SIL2: mean probability of undetected hazardous failure per hour between  $10^{-6}$  and  $10^{-7}$ ).

<sup>(1)</sup> Redundant: consists of mitigating the effects of failure of one component by means of the correct operation of another, assuming that faults do not occur simultaneously on both.

**"Power Removal" safety function considerations**

The "Power Removal" safety function cannot be considered as a means of electrical disconnection of the motor (no electrical isolation); if necessary, a Vario switch disconnecter must be used.

The "Power Removal" safety function is not designed to overcome any malfunction in the drive process control or application functions.

The output signals available on the drive must not be considered as safety signals (e.g. "Power Removal" active); these are Preventa-type safety module outputs which must be integrated into a safety control-signalling circuit.

The schemes on the following pages take into account conformity to standard IEC/EN 60204-1 which defines 3 categories of stop:

- Category 0: Stopping by immediate removal of the power from the actuators (e.g. uncontrolled stop)
- Category 1: Controlled stop maintaining the power on the actuators until the machine stops, then removal of the power when the actuators stop once stopping is achieved
- Category 2: Controlled stop maintaining the power on the actuators

**Connection schemes and applications****Conforming to category 1 of standard EN 954-1 and level SIL1 according to standard IEC/EN 61508**

Use of the connection schemes on pages 214 and 215 which use a line contactor or a Vario switch disconnecter between the drive and the motor. In this case, the "Power Removal" safety function is not used and the motor stops in accordance with category 0 of standard IEC/EN 60204-1.

**Conforming to category 3 of standard EN 954-1 and level SIL2 according to standard IEC/EN 61508**

The connection schemes use the "Power Removal" safety function of the Altivar 61 drive combined with a Preventa safety module to monitor the emergency stop circuits.

**Machines with short freewheel stopping times** (low inertia, see page 216).

When the activation command is given on the PWR input with the controlled motor, the motor power supply is immediately switched off and the motor stops according to category 0 of standard IEC/EN 60204-1.

Restarting is not permitted even when the activation command is given after the motor has come to a complete stop ("STO").

This safe stop is maintained while the PWR input remains activated.

**Machines with long freewheel stopping times** (high inertia, see page 217).

When the activation command is given, deceleration of the motor controlled by the drive is first requested, then, following a time delay controlled by a Preventa-type fault relay (1) which corresponds to the deceleration time, the "Power Removal" safety function is activated by the PWR input. The motor stops according to category 1 of standard IEC/EN 60204-1 ("SS1").

**Periodic test**

The "Power Removal" safety input must be activated at least once a year for preventive maintenance purposes. The drive must be switched off before preventive maintenance takes place, and then powered up again. If the power supply to the motor is not switched off during testing, safety integrity is no longer assured for the "Power Removal" safety function. The drive must therefore be replaced to ensure the operational safety of the machine or of the system process.

(1) Please refer to the "Safety solutions using Preventa" catalogue.

### Applications in a potentially explosive atmosphere (ATEX)

#### Classification of zones

European directive 1999/92/EC (referred to as the ATEX 137 directive, or worker protection directive) classifies the ATEX zones and compatible product types. It is the user's responsibility to define the ATEX zone where the ATEX motor controlled by the Altivar 61 variable speed drive will be installed.

The Altivar 61 variable speed drive must always be installed outside the hazardous ATEX zone. The various installation schemes proposed in the ATEX guide (1) are compatible with operation of the ATEX motor in zone 1, 21, 2 or 22.

The table below summarizes the characteristics relating to each ATEX zone.

Atmosphere	Zone	Definition	Time and presence of explosive atmosphere Hours/year
Gas	0	The explosive atmosphere is present continuously, or for long periods, or frequently owing to malfunctions	> 1000 hrs
Dust	20		
Gas	1	The explosive atmosphere can be present owing to probable malfunctions	10...1000 hrs
Dust	21		
Gas	2	The presence of an explosive atmosphere is unlikely and, if it does occur, will persist for a short duration and not during normal operation	< 10 hrs
Dust	22		

**Note:** Installation of electrical equipment and motors is prohibited in ATEX zone 0 or 20.

#### General considerations

European directive 94/9/EC (also referred to as directive ATEX 95, or product directive) defines the constraints applicable to ATEX products and the associated certification requirements.

The OEM, the installer and the user are responsible for the selection and operation of the components they use to provide ATEX protection of the systems they design or operate:

- The motor must be ATEX certified and compatible with use in zone 1, 21, 2 or 22
- The motor must be equipped with ATEX certified thermal sensor switch(es), or ATEX certified thermal sensor(s), combined with a control unit, itself ATEX certified.

**Caution:** In general, the control units are designed to operate outside the hazardous ATEX zone. It is then possible to place these control units close to the variable speed drive, in the protected zone.

#### Thermal protection of the ATEX motor

Use of the "Power Removal" safety function enables the variable speed drive to provide thermal protection in the event of excessive temperature rise of the ATEX motor, but does not enable it to safely control and regulate the temperature of the ATEX motor.

All motor types ATEX certified for use in zone 1, 21, 2 or 22, which are equipped with ATEX thermal sensors, can be protected by the Altivar 61 variable speed drive.

The switching device, integrated with the thermal sensor or integrated with the thermal protection control unit of the ATEX motor, must be connected to the PWR safety input of the Altivar 61 variable speed drive. When the excessive temperature of the ATEX motor is reached, the control device automatically triggers the "Power Removal" safety function. The electrical power supply of the motor is then switched off in order to ensure a temperature of the motor casing lower than the temperature that is dangerous for the gas or dust mixture in which the ATEX motor is installed. When the ATEX application requires the use of the "Power Removal" safety function, the safety module (of Preventa type) (2) must be used. The schemes proposed in the ATEX guide (1) show how the switching devices, integrated with the thermal sensor or with the thermal protection control unit, are connected to the safety module. The safety module output must be connected to the PWR safety input of the Altivar 61 variable speed drive.

(1) Please refer to the ATEX guide, which is available on our website at [www.telemecanique.com](http://www.telemecanique.com).

(2) Please refer to the "Safety solutions using Preventa" catalogue.

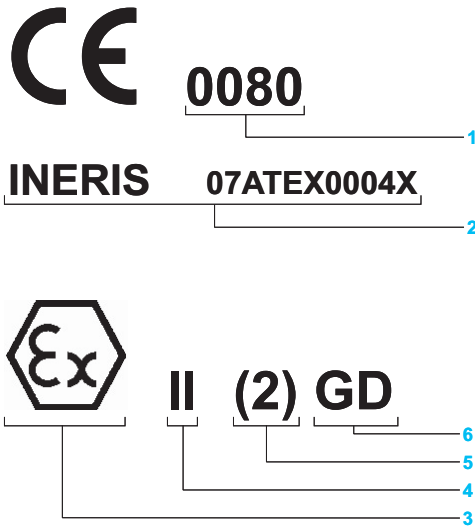
**ATEX marking identification**

ATEX certified Altivar 61 variable speed drives can be identified by the marking corresponding to all the applications covered by the drive's ATEX certification.

- 1 0080** corresponds to the identification number of the INERIS notified body that issued the notifications for the quality assurance systems for the drive production units in compliance with EN 50980.
- 2 INERIS 07ATEX0004X** corresponds to the identification of the certification report issued by the INERIS notified body for conformity of the variable speed drive with the requirements of ATEX directive 94/9/EC.
- 3**  The logo corresponds to the identification of an ATEX product
- 4 II** allows the equipment to be used in ATEX surface applications (use prohibited for mining applications).
- 5 (2)** The brackets "( )" identify the Altivar 61 variable speed drive as being equipment associated with the control and signalling of an ATEX motor installed in a hazardous zone. The figure **2** corresponds to identification of the ATEX motor as category 2 equipment, for use in ATEX zone 1 or 21.  
*Note: Category 3 motors for use in ATEX zone 2 or 22 are also covered by this marking.*
- 6 G**, for Gas, corresponds to ATEX applications for explosive gas atmospheres.  
**D**, for Dust, corresponds to ATEX applications for atmospheres containing an explosive dust mixture.

**General**

Operation of the equipment and the cable connection method must comply with the local regulations in the installation location. The rules given by ATEX installation standards, when applicable, should also be observed:

- IEC 60079-14 for applications in an explosive gas atmosphere
  - IEC 61241-14 for applications in a combustible dust atmosphere
- In zone 1 or 2, for applications in an explosive gas atmosphere, the requirements of IEC 60079-14 apply to the installation:

- **IEC 60079-14**: Electrical apparatus for explosive gas atmospheres
- **Part 14**: Electrical installations in hazardous areas (other than mines).

In zone 21 or 22, for applications in a combustible dust atmosphere, the requirements of IEC 61241-14 apply to the installation:

- **IEC 61241-14**: Electrical apparatus for use in the presence of combustible dust
- **Part 14**: Selection and installation.

The schemes proposed in the ATEX guide (1) for the use of Altivar 61 variable speed drives in ATEX applications take account of the nature of the thermal sensors mounted in the ATEX motor.

**Note: Motor stopping categories according to standard IEC/EN 60204-1**

The installation schemes proposed in the ATEX guide (1) show the use of the Preventa XPS-AC safety module (2) in combination with an ATEX application for implementing the safety function in stopping category 0 according to standard IEC/EN 60204-1.

The user should make sure that use of the delayed activation fault relay (Preventa XPS-ATE module) (2) is compatible in combination with its ATEX application, for stopping category 1 according to standard IEC/EN 60204-1.

**Periodic ATEX test**

For preventive maintenance, the complete safety loop (starting from the thermal sensors of the ATEX motor up to the "Power Removal" safety function incorporated in the drive) must be tested at least once a year, in order to verify that, in the event of excessive temperature rise, the electrical power supply of the ATEX motor is always cut off automatically.

(1) Please refer to the ATEX guide, which is available on our website at [www.telemecanique.com](http://www.telemecanique.com).

(2) Please refer to the "Safety solutions using Preventa" catalogue.

**Schemes conforming to standards EN 954-1 category 1, IEC/EN 61508 SIL1 capability, in stopping category 0 according to IEC/EN 60204-1**

ATV 61H●●●M3, ATV 61H●●●M3X, ATV 61●●●●N4, ATV 61W●●●N4C, ATV 61H●●●Y

Three-phase power supply with upstream breaking via contactor

ATV 61H075M3...HU75M3

Power section for single-phase power supply

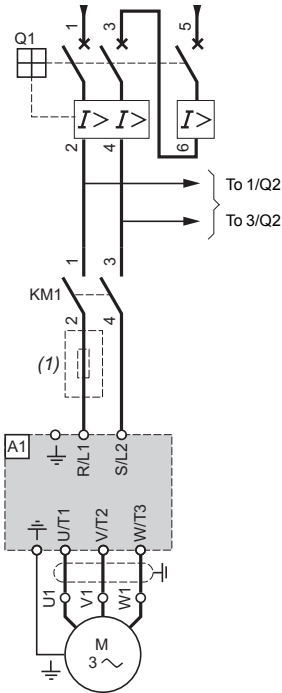
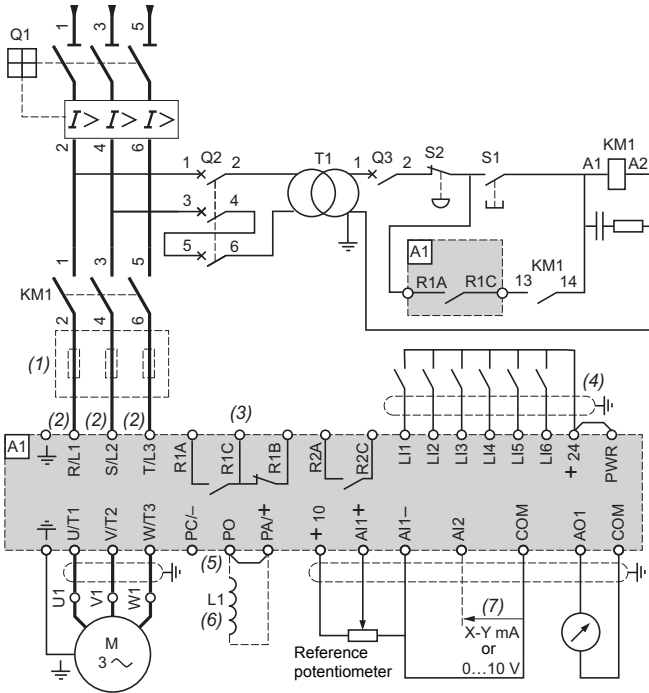

**Note:** All terminals are located at the bottom of the drive. Fit interference suppressors on all inductive circuits near the drive or connected on the same circuit, such as relays, contactors, solenoid valves, fluorescent lighting, etc.

**Components for use with the Altivar** (for a complete list of references, see our catalogue "Motor starter solutions. Control and protection components").

Ref.	Description
A1	ATV 61 drive, see pages 20 to 25
KM1	Contactors, see motor starters pages 228 to 239
L1	DC choke, see page 149
Q1	Circuit-breaker, see motor starters pages 228 to 239
Q2	GV2 L rated at twice the nominal primary current of T1
Q3	GB2 CB05
S1, S2	XB4 B or XB5 A pushbuttons
T1	100 VA transformer 220 V secondary

- (1) Line choke (single-phase or three-phase), mandatory for ATV 61HU40M3...HU75M3 drives supplied with single-phase 220...240 V 50/60 Hz and ATV 61HC11Y...HC80Y drives (unless a special transformer is used (12 pulses)), see page 154.
- (2) For ATV 61HC50N4, ATV 61HC63N4 and ATV 61HC50Y...HC80Y drives, see page 214.
- (3) Fault relay contacts. Used for remote signalling of the drive status.
- (4) Connection of the common for the logic inputs depends on the positioning of the SW1 switch: see schemes on page 214.
- (5) There is no PO terminal on ATV 61HC11Y...HC80Y drives.
- (6) Optional DC choke for ATV 61H●●●M3, ATV 61HD11M3X...HD45M3X, ATV 61H075N4...HD75N4. Connected in place of the strap between the PO and PA+ terminals. For ATV 61HD55M3X...HD90M3X, ATV 61HD90N4...HC63N4 drives, the choke is supplied with the drive; the customer is responsible for connecting it. For ATV 61W●●●N4 and ATV 61W●●●N4C drives, the DC choke is integrated.
- (7) Software-configurable current (0...20 mA) or voltage (0...10 V) analog input.

## Schemes conforming to standards EN 954-1 category 1, IEC/EN 61508 SIL1 capability, in stopping category 0 according to IEC/EN 60204-1 (continued)

ATV 61H●●●M3, ATV 61H●●●M3X, ATV 61●●●●N4, ATV 61W●●●N4C,  
ATV 61H●●●Y

Three-phase power supply with downstream breaking via switch disconnector

ATV 61H075M3...HU75M3

Power section for single-phase power supply

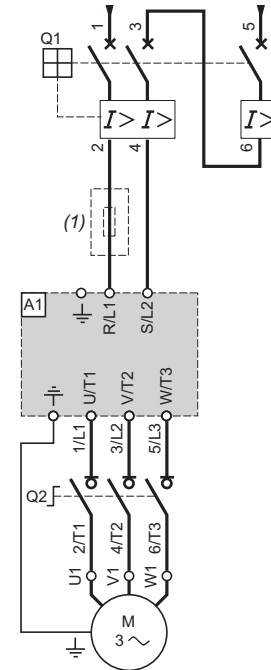
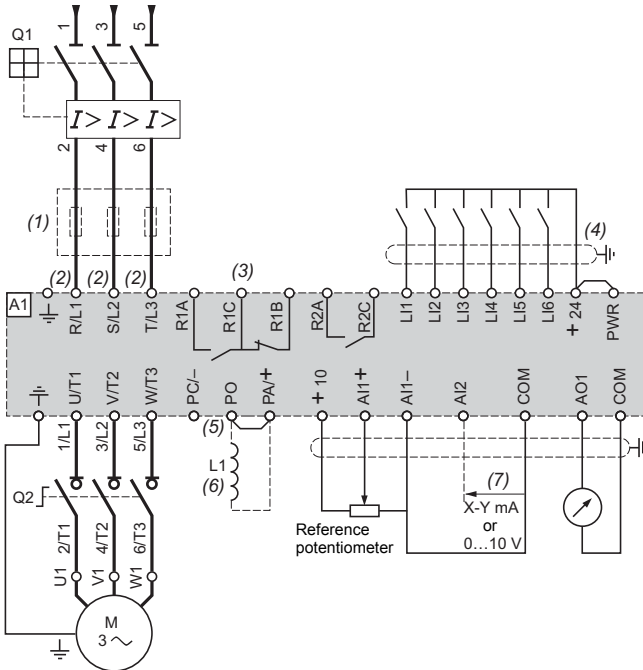

**Note:** All terminals are located at the bottom of the drive. Fit interference suppressors on all inductive circuits near the drive or connected on the same circuit, such as relays, contactors, solenoid valves, fluorescent lighting, etc.

**Components for use with the Altivar** (for a complete list of references, see our catalogue "Motor starter solutions. Control and protection components").

Ref.	Description
A1	ATV 61 drive, see pages 20 to 25
L1	DC choke, see page 149
Q1	Circuit-breaker, see motor starters pages 228 to 239
Q2	Switch disconnector (Vario)

(1) Line choke (single-phase or three-phase), mandatory for ATV 61HU40M3...HU75M3 drives supplied with single-phase 220...240 V 50/60 Hz and ATV 61HC11Y...HC80Y drives (unless a special transformer is used (12 pulses)), see page 154.

(2) For ATV 61HC50N4, ATV 61HC63N4 and ATV 61HC50Y...HC80Y drives, see page 214.

(3) Fault relay contacts. Used for remote signalling of the drive status.

(4) Connection of the common for the logic inputs depends on the positioning of the SW1 switch: see schemes on page 214.

(5) There is no PO terminal on ATV 61HC11Y...HC80Y drives.

(6) Optional DC choke for ATV 61H●●●M3, ATV 61HD11M3X...HD45M3X, ATV 61H075N4...HD75N4. Connected in place of the strap between the PO and PA/+ terminals. For ATV 61HD55M3X...HD90M3X, ATV 61HD90N4...HC63N4 drives, the choke is supplied with the drive; the customer is responsible for connecting it. For ATV 61W●●●N4 and ATV 61W●●●N4C drives, the DC choke is integrated.

(7) Software-configurable current (0...20 mA) or voltage (0...10 V) analog input.

**Schemes conforming to standards EN 954-1 category 3, IEC/EN 61508 SIL2 capability, in stopping category 0 according to IEC/EN 60204-1**

ATV 61H●●●M3, ATV 61H●●●M3X, ATV 61●●●●N4, ATV 61W●●●N4C, ATV 61H●●●Y

Three-phase power supply, low inertia machine

ATV 61H075M3...HU75M3

Power section for single-phase power supply

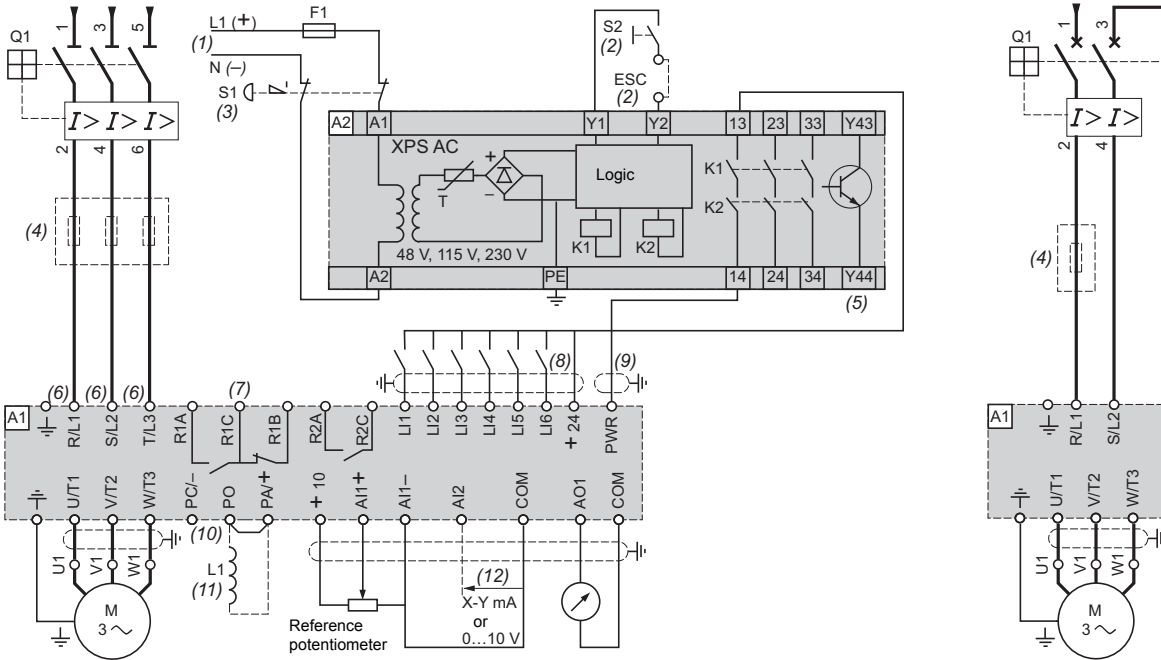

**Note:** All terminals are located at the bottom of the drive. Fit interference suppressors on all inductive circuits near the drive or connected on the same circuit, such as relays, contactors, solenoid valves, fluorescent lighting etc.

**Components for use with the Altivar** (for a complete list of references, see our catalogues "Motor starter solutions. Control and protection components" and "Safety solutions using Preventa").

Ref.	Description
A1	ATV 61 drive, see pages 20 to 25
A2	Preventa XPS AC safety module for monitoring emergency stops and switches. One safety module can manage the "Power Removal" function for several drives on the same machine. In this case, the PWR terminal on each drive must be connected to the + 24 V via the safety contacts on the XPS AC module.
F1	Fuse
L1	DC choke, see page 149
Q1	Circuit-breaker, see motor starters pages 228 to 239
S1	Emergency stop button with 2 contacts
S2	XB4 B or XB5 A pushbutton

- (1) Power supply:  $\sim$  or  $\sim$ , 115 V  $\sim$ , 230 V  $\sim$ .
- (2) S2: resets the XPS AC module on power-up or after an emergency stop. ESC can be used to set external starting conditions.
- (3) Requests freewheel stopping of the movement and activates the "Power Removal" safety function.
- (4) Line choke (single-phase or three-phase), mandatory for ATV 61HU40M3...HU75M3 drives supplied with single-phase 220...240 V 50/60 Hz and ATV 61HC11Y...HC80Y drives (unless a special transformer is used (12 pulses)), see page 154.
- (5) The logic output can be used to signal that the machine is in a safe stop state.
- (6) For ATV 61HC50N4, ATV 61HC63N4 and ATV 61HC50Y...HC80Y drives, see page 214.
- (7) Fault relay contacts. Used for remote signalling of the drive status.
- (8) Connection of the common for the logic inputs depends on the positioning of the SW1 switch: see schemes on page 214.
- (9) Standardized coaxial cable, type RG174/U according to MIL-C17 or KX3B according to NF C 93-550, external diameter 2.54 mm, maximum length 15 m. The cable shielding must be earthed.
- (10) There is no PO terminal on ATV 61HC11Y...HC80Y drives.
- (11) Optional DC choke for ATV 61H●●●M3, ATV 61HD11M3X...HD45M3X, ATV 61H075N4...HD75N4. Connected in place of the strap between the PO and PA/+ terminals. For ATV 61HD55M3X...HD90M3X, ATV 61HD90N4...HC63N4 drives, the choke is supplied with the drive; the customer is responsible for connecting it. For ATV 61W●●●N4 and ATV 61W●●●N4C drives, the DC choke is integrated.
- (12) Software-configurable current (0...20 mA) or voltage (0...10 V) analog input.

**Schemes conforming to standards EN 954-1 category 3, IEC/EN 61508 SIL2 capability, in stopping category 1 according to IEC/EN 60204-1**

ATV 61H●●●M3, ATV 61H●●●M3X, ATV 61●●●●N4, ATV 61W●●●N4C, ATV 61H●●●Y

Three-phase power supply, high inertia machine

ATV 61H075M3...HU75M3

Power section for single-phase power supply

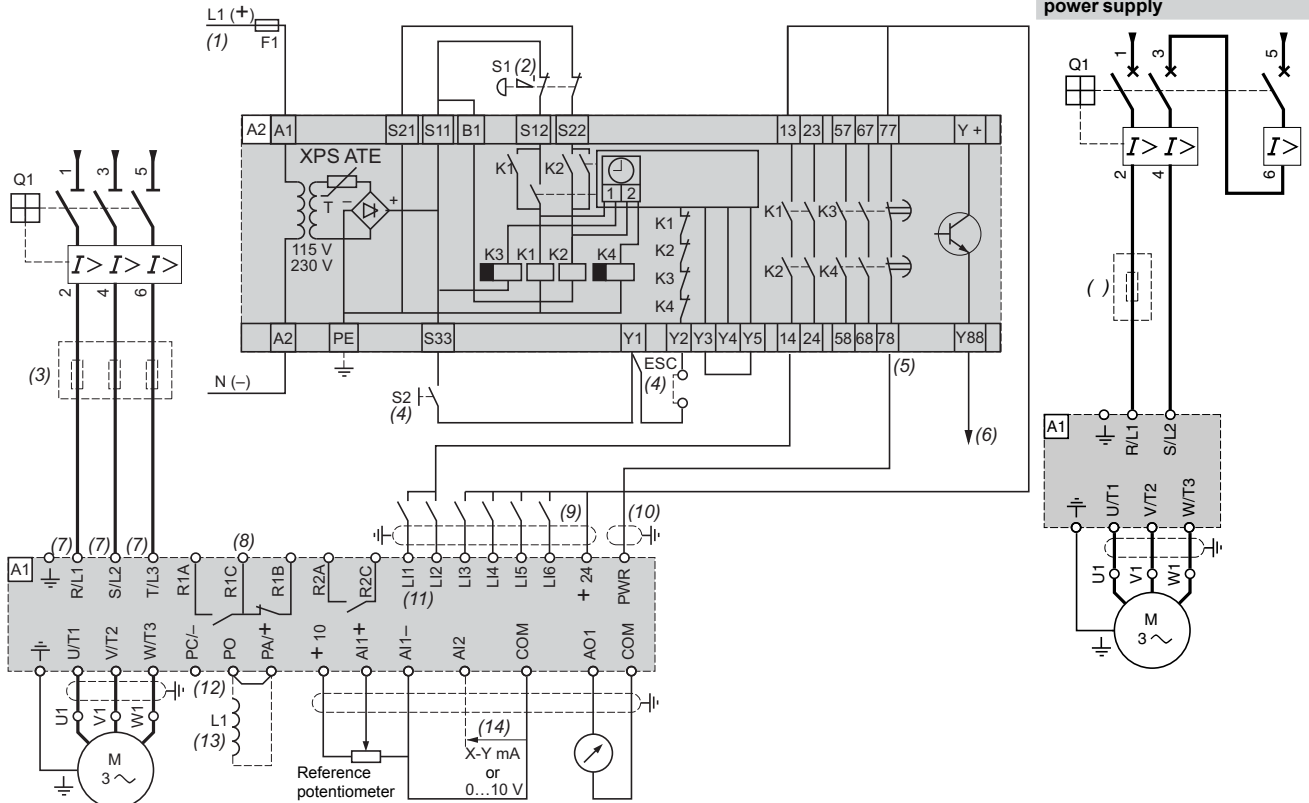

**Note:** All terminals are located at the bottom of the drive. Fit interference suppressors on all inductive circuits near the drive or connected on the same circuit, such as relays, contactors, solenoid valves, fluorescent lighting etc.

**Components for use with the Altivar** (for a complete list of references, see our catalogues "Motor starter solutions. Control and protection components" and "Safety solutions using Preventa").

Ref.	Description
A1	ATV 61 drive, see pages 20 to 25
A2 (6)	Preventa XPS ATE safety module for monitoring emergency stops and switches. One safety module can manage the "Power Removal" safety function for several drives on the same machine. In this case the time delay must be adjusted on the drive controlling the motor that requires the longest stopping time. In addition, the PWR terminal on each drive must be connected to the + 24 V via the safety contacts on the XPS ATE module.
F1	Fuse
L1	DC choke, see page 149
Q1	Circuit-breaker, see motor starters pages 228 to 239
S1	Emergency stop button with 2 contacts
S2	XB4 B or XB5 A pushbutton

- (1) Power supply:  $\sim$  or  $\sim$ , 115 V  $\sim$ , 230 V  $\sim$ .
- (2) Requests controlled stopping of the movement and activates the "Power Removal" safety function.
- (3) Line choke (single-phase or three-phase), mandatory for ATV 61HU40M3...HU75M3 drives supplied with single-phase 220...240 V 50/60 Hz and ATV 61HC11Y...HC80Y drives (unless a special transformer is used (12 pulses)), see page 154.
- (4) S2: resets the XPS AT module on power-up or after an emergency stop. ESC can be used to set external starting conditions.
- (5) The "N/C" contact can be used to signal that the machine is in a safe stop state.
- (6) For stopping times requiring more than 30 seconds in category 1, use a Preventa XPS AV safety module which can provide a maximum time delay of 300 seconds.
- (7) For ATV 61HC50N4, ATV 61HC63N4 and ATV 61HC50Y...HC80Y drives, see page 214.
- (8) Fault relay contacts. Used for remote signalling of the drive status.
- (9) Connection of the common for the logic inputs depends on the positioning of the SW1 switch: see schemes on page 214.
- (10) Standardized coaxial cable, type RG174/U according to MIL-C17 or KX3B according to NFC 93-550, external diameter 2.54 mm, maximum length 15 m. The cable shielding must be earthed.
- (11) Logic inputs L1 and L2 must be assigned to the direction of rotation: L1 to forward direction and L2 to reverse direction.
- (12) There is no PO terminal on ATV 61HC11Y...HC80Y drives.
- (13) Optional DC choke for ATV 61H●●●M3, ATV 61HD11M3X...HD45M3X, ATV 61H075N4...HD75N4. Connected in place of the strap between the PO and PA/+ terminals. For ATV 61HD55M3X...HD90M3X, ATV 61HD90N4...HC63N4 drives, the choke is supplied with the drive; the customer is responsible for connecting it. For ATV 61W●●●N4 and ATV 61W●●●N4C drives, the DC choke is integrated.
- (14) Software-configurable current (0...20 mA) or voltage (0...10 V) analog input.



### Power terminal connections

For ATV 61HC50N4, ATV 61HC63N4 and ATV 61HC50Y...HC80Y

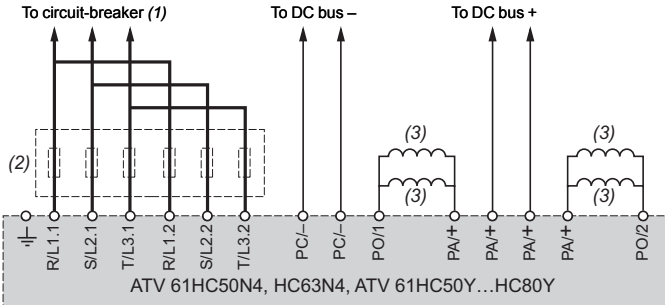

- (1) For control section connections, see pages 210 to 213.
- (2) Line chokes, see pages 153 and 154; these are mandatory for ATV 61HC50Y...HC80Y drives, and should be ordered separately.
- (3) DC chokes supplied as standard with ATV 61HC50N4 and HC63N4 drives. They are not available for ATV 61HC50Y...HC80Y drives.

### Braking resistors VW3 A7 7 or braking units VW3 A7 1

ATV 61H...M3, ATV 61HD11M3X...HD45M3X,  
ATV 61H075N4...HD75N4,  
ATV 61HU30Y...HD90Y, ATV 61W...N4,  
ATV 61W...N4C

ATV 61HD55M3X...HD90M3X,  
ATV 61HD90N4...HC22N4,  
ATV 61HC11Y...HC20Y

ATV 61HC25N4...HC63N4,  
ATV 61HC25Y...HC80Y

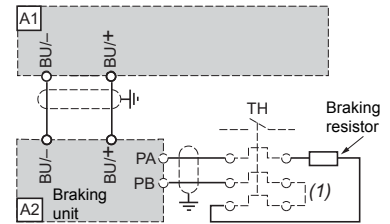
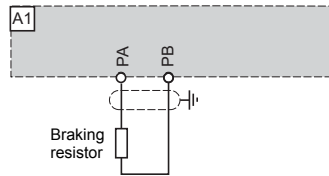
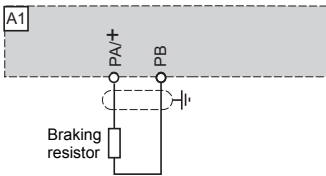

### Components for use with the Altivar

Ref.	Description
A1	ATV 61 drive, see pages 20 to 25
A2	Braking unit if using a braking resistor for ATV 61HC25N4...HC63N4 and ATV 61HC25Y...HC80Y, see page 137
Braking resistor	See pages 140 and 141

(1) A thermal overload relay can be added; its contact must be integrated into the control circuit.

### Examples of recommended schemes

#### Logic inputs

The SW1 switch is used to adapt operation of the logic inputs (LI) to the PLC output technology:

- Set the switch to Source (factory setting) if using PLC outputs with PNP transistors
- Set the switch to Sink Int. or Sink Ext. if using PLC outputs with NPN transistors

#### Internal power supply

##### Switch in "Source" position

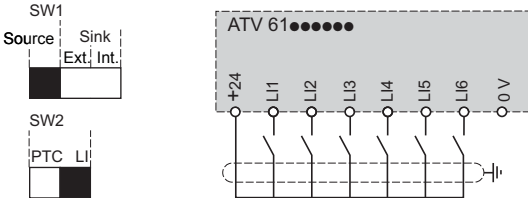

##### Switch in "Sink Int" position

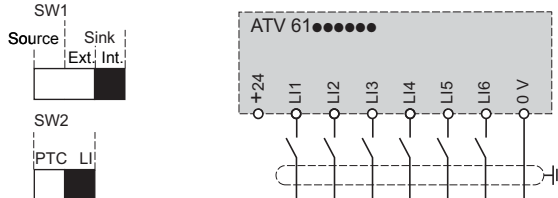

#### External power supply

##### Switch in "Source" position

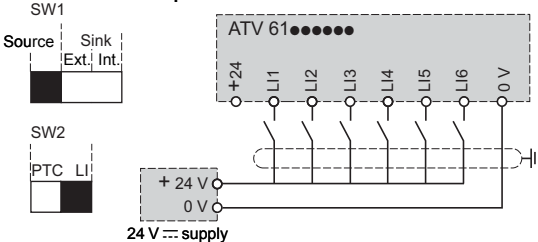

##### Switch in "Sink Ext" position

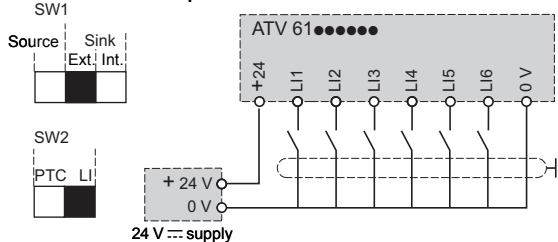

### Examples of recommended schemes (continued)

#### Input for PTC probes

The SW2 switch is used to operate the LI6 input:

- As a logic input by setting the SW2 switch to LI (factory setting)
- Or for protecting the motor via PTC probes by setting the SW2 switch to PTC

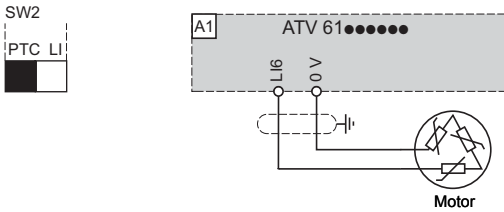

#### 2-wire control and jog operation (JOG)

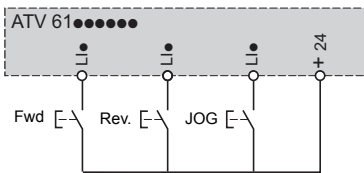

#### 3-wire control and jog operation (JOG)

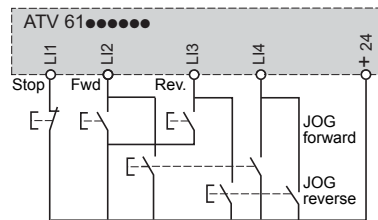

#### Unipolar speed reference

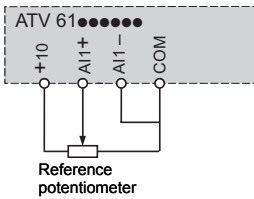

#### Bipolar speed reference

Requires an I/O extension card VW3 A3 201 or VW3 A3 202

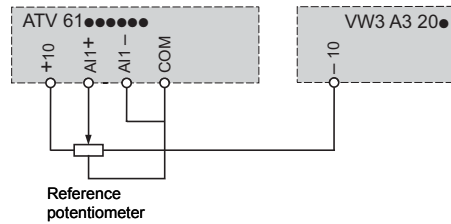

#### Separate control power supply

The separate control card can be powered by an external 24 V  $\overline{\text{---}}$  supply

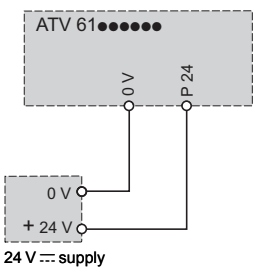

#### Analogue input configured for voltage

External 0...10 V

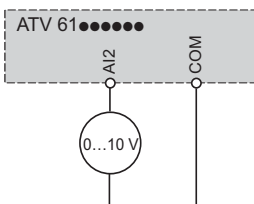

External + 10 V

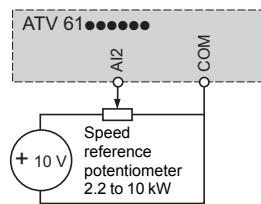

#### Analogue input configured for current

0-20 mA, 4-20 mA, X-Y mA

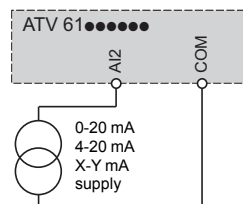

### I/O extension cards VW3 A3 201 and VW3 A3 202

#### Logic I/O

The SW3 or SW4 switch is used to adapt operation of the logic inputs (LI) to the PLC output technology:

- Set the switch to Source (factory setting) if using PLC outputs with PNP transistors
- Set the switch to Sink Int. or Sink Ext. if using PLC outputs with NPN transistors

#### Internal power supply

Switch in "Source" position

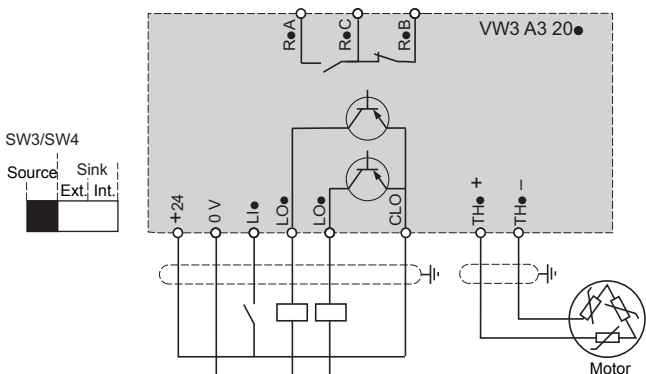

Switch in "Sink Int" position

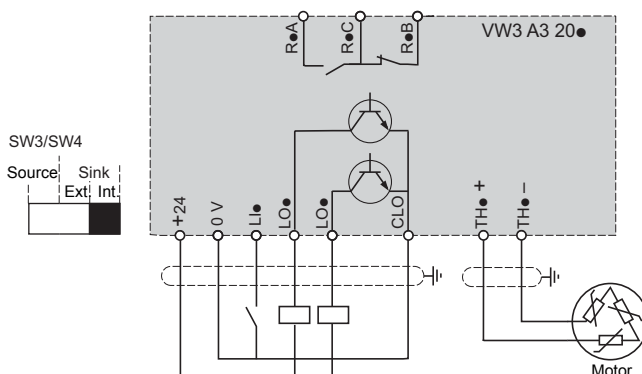

#### External power supply

Switch in "Source" position

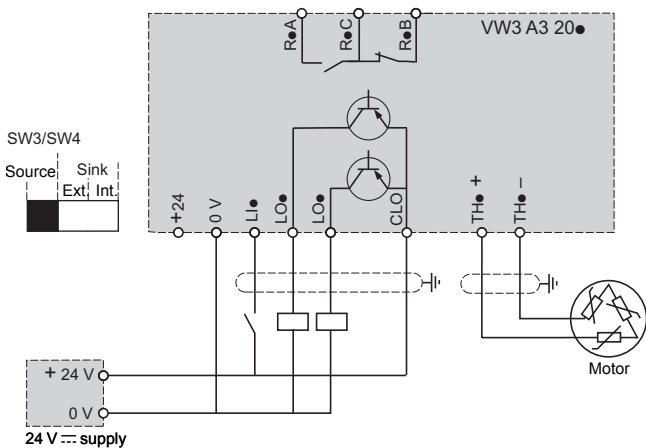

Switch in "Sink Ext" position

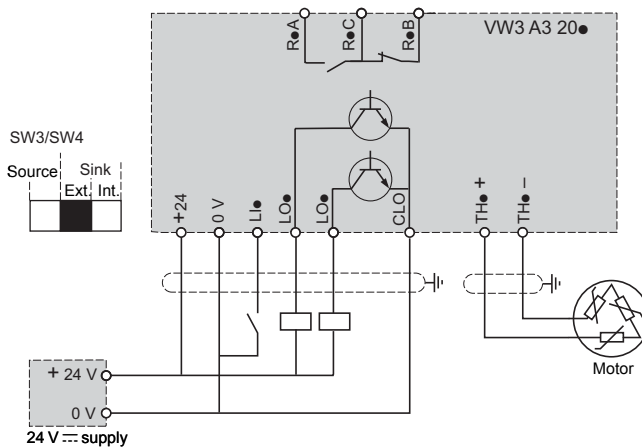

#### Analog I/O (only on extended I/O card VW3 A3 202)

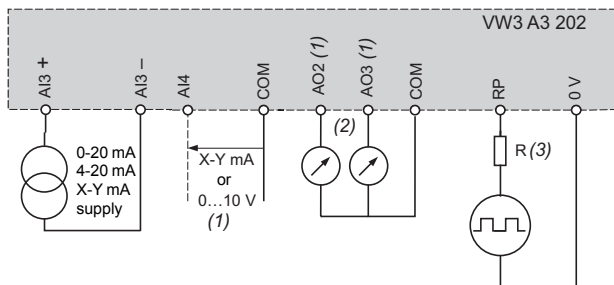

- (1) Software-configurable current (0-20 mA) or voltage (0...10 V) analog input.  
 (2) Software-configurable current (0-20 mA) or voltage ( $\pm 10$  V or 0...10 V) analog outputs, independent selection possible for each output via switch.  
 (3) R: add a resistor if the input voltage of the pulse train is greater than 5 V.

Recommended values:

Input voltage V	Resistance $\Omega$
12	510
15	910
24	1300

### Multi-pump cards VW3 A3 502 and VW3 A3 503, "Controller Inside" programmable card VW3 A3 501

Card powered by the drive (1)

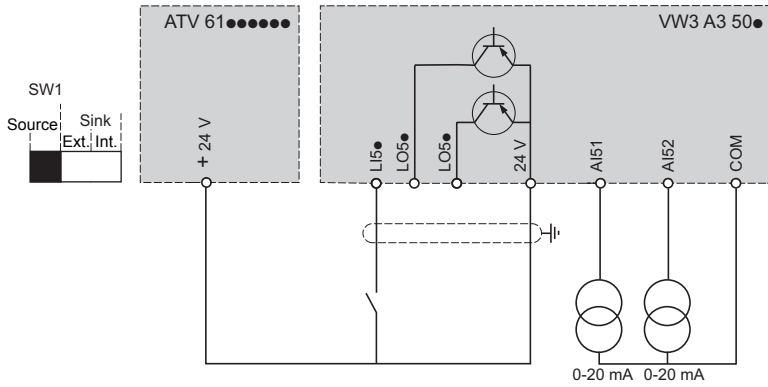

Card powered by external power supply

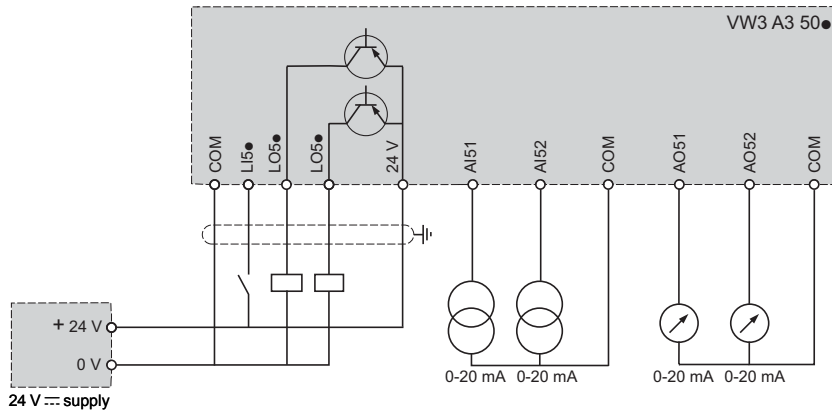

### Encoder interface cards VW3 A3 401, VW3 A3 403 to VW3 A3 407

Wiring of encoders VW3 A3 401, 403...407  
A,  $\bar{A}$ , B,  $\bar{B}$  signals

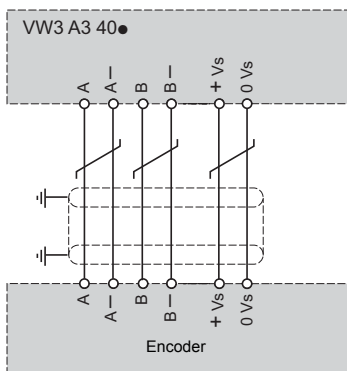

Wiring of encoders VW3 A3 403...407  
AB signals

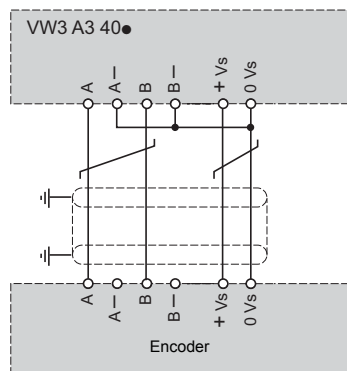

Wiring of encoders VW3 A3 403...407  
A signal

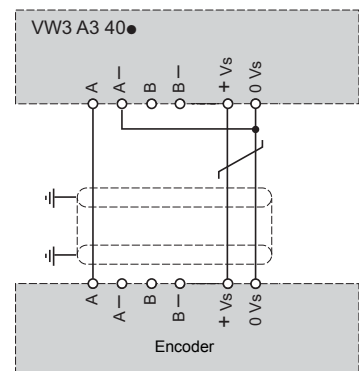

(1) Only if the power consumption is less than 200 mA; otherwise use an external power supply.

### Passive filters VW3 A4 6●●

#### Scheme with 1 passive filter for ATV 61H075N4...HC11N4 drives

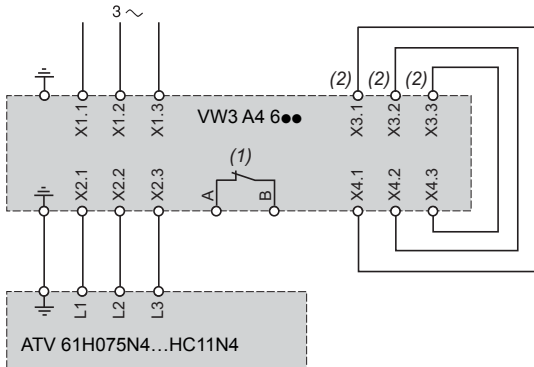

#### Scheme with 1 passive filter for ATV 61HC13N4...HC63N4 drives

##### Connection downstream of the line contactor

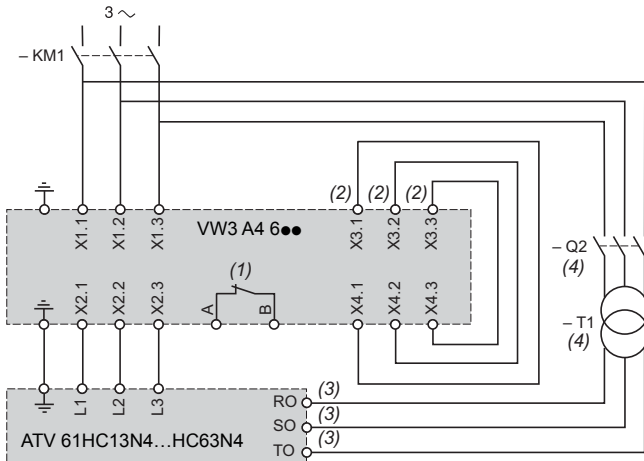

##### Connection upstream of the line contactor

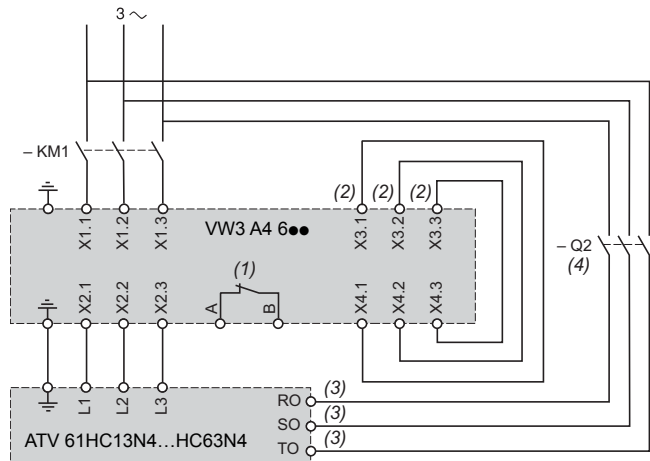

#### Scheme with 2 passive filters for ATV 61H075N4...HC11N4 drives

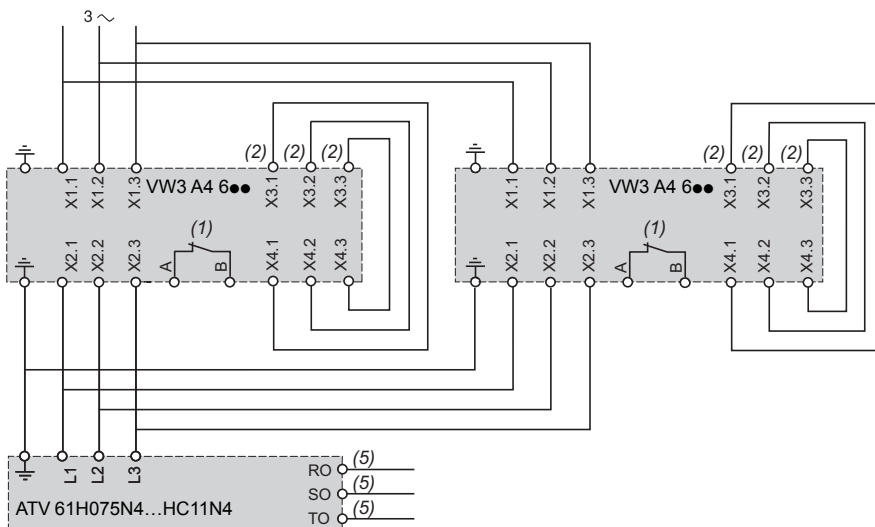

(1) Contact for indicating the thermal state of the passive filter, to be connected in the safety circuit of the installation.

(2) Delivered wired.

(3) Fan external power supply

(4) Q2: GV2 RT10 thermal magnetic motor circuit-breaker. T1: 400/400 V or 460/460 V transformer.

(5) For ATV 61HC13N4...HC63N4 drives, the external power supply for the fan is mandatory, see scheme above with one passive filter.

### Passive filters VW3 A4 6●● (continued)

#### Scheme with 3 passive filters for ATV 61H075N4...HC11N4 drives

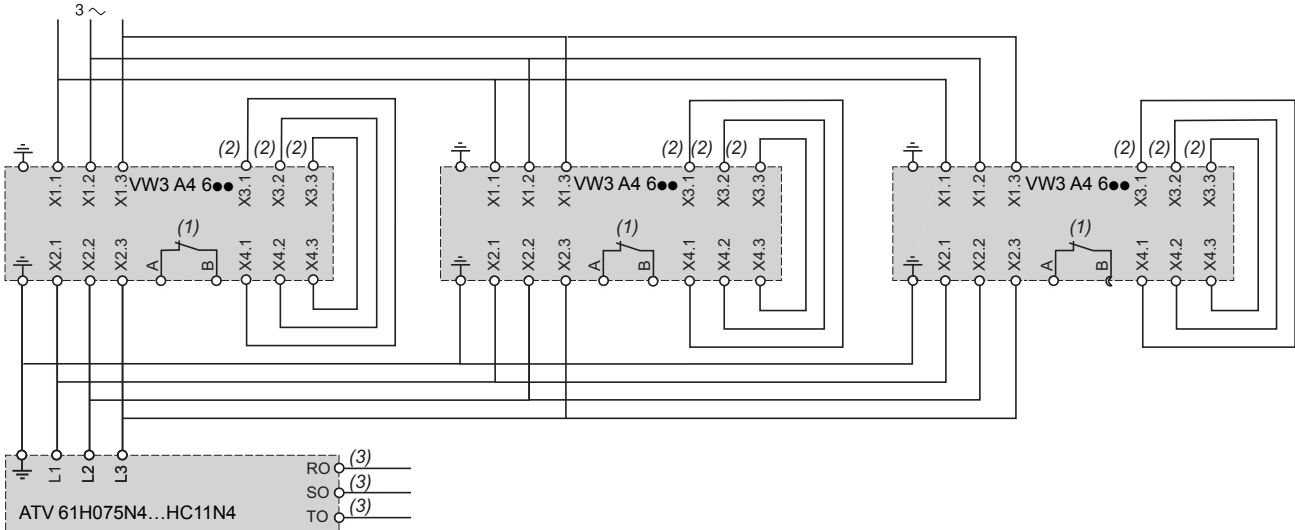

#### Scheme for controlling the filter via the drive according to the load

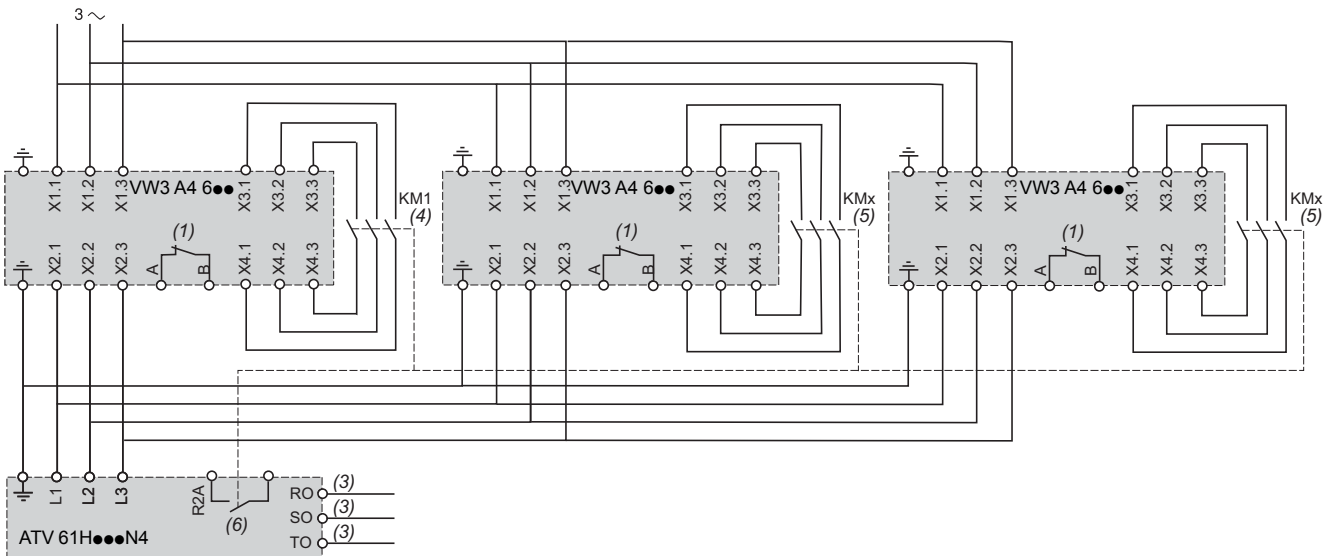

(1) Contact for indicating the thermal state of the passive filter, to be connected in the safety circuit of the installation.

(2) Delivered wired.

(3) For ATV 61HC13N4...HC63N4 drives, the external power supply for the fan is mandatory, see scheme on opposite page with one passive filter.

(4) KM1: category AC1 contactor sized at 50% of the drive nominal current (In).

(5) KMx: contactor type and sizing identical to KM1. It may be necessary to provide an intermediate relay to control the KMx contactors.

(6) The logic output at relay R2A must be assigned to the "Current threshold reached" (CtA) parameter.

**Additional EMC input filters VW3 A4 4●●**

Three-phase power supply, three-phase filter

Single-phase power supply, three-phase filter

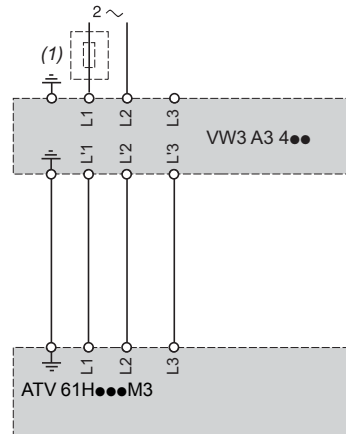
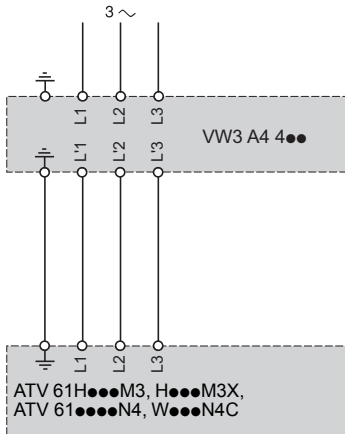

(1) Line choke mandatory for ATV 61HU40M3...HU75M3, see page 153.

**Output filters**

Motor chokes VW3 A5 1●●

Sinus filters VW3 A5 2●●

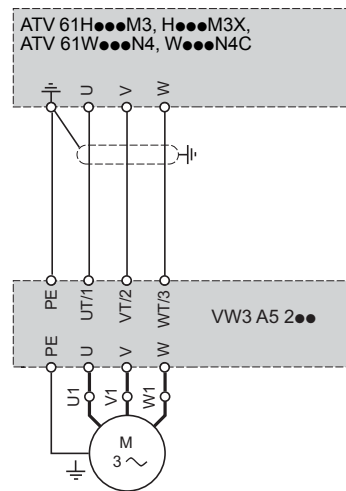
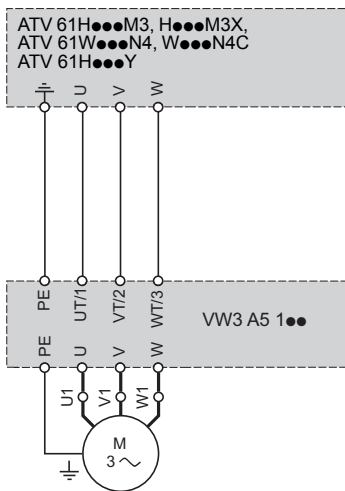

### Drives combined with a braking unit and wired onto the same DC bus

ATV 61HC25N4...HC63N4, ATV 61 HC25Y...HC80Y

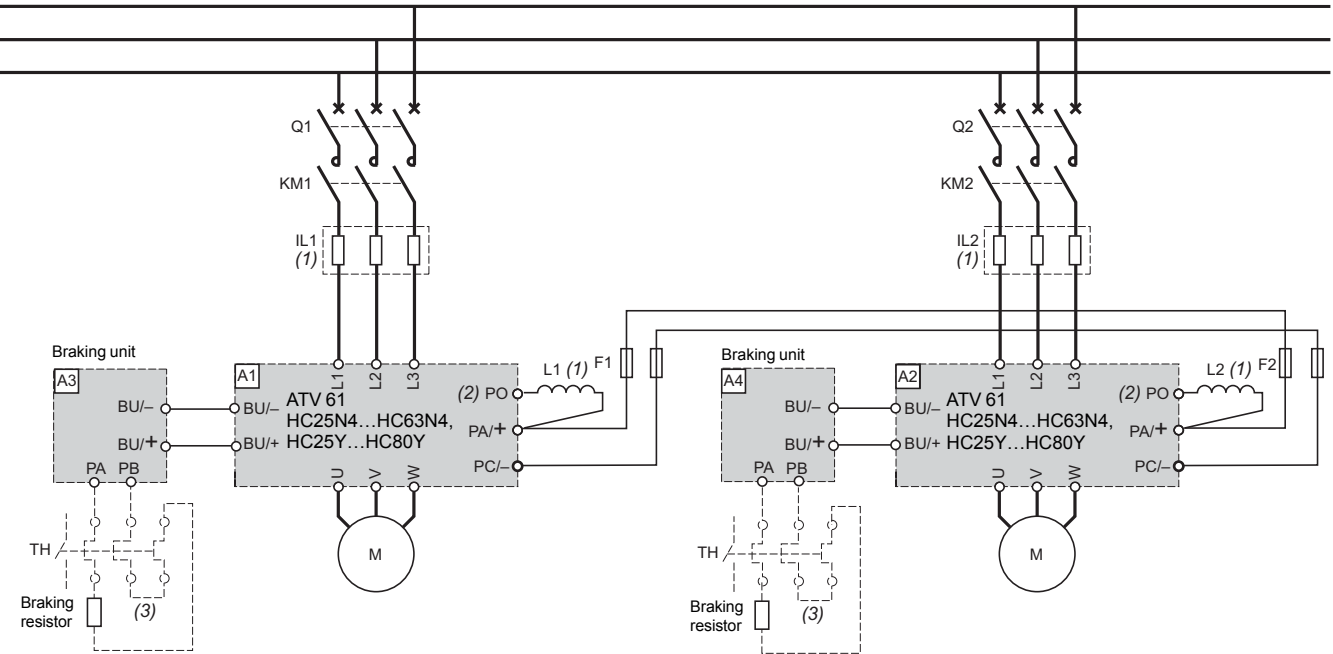

Ref.	Description
A1, A2	ATV 61 drives, see pages 21 and 23.
A3, A4	Braking units, see pages 136 and 137.
F1, F2, F3	Fast-acting semi-conductor fuses, see page 225. The function of the fuses is to protect the DC bus wiring in the event of a drive short-circuit.
IL1, IL2 (1)	Line chokes mandatory for ATV 71HC25Y...HC80Y drives; to be ordered separately, see page 154.
KM1, KM2	Line contactors. Rating: see motor starters on pages 230, 231, 234, 235, 238 and 239.
L1, L2 (1)	DC chokes mandatory for ATV 61HC25N4...HC63N4 drives and supplied as standard. Not used for ATV 71HC25Y...HC80Y drives, which require the presence of line chokes (IL●).
Q1, Q2	Circuit-breakers. Rating: see motor starters on pages 230, 231, 234, 235, 238 and 239.

(1) The use of line chokes or DC chokes depends on the drive type, see table above.

(2) There is no PO terminal on ATV 61HC25Y...HC80Y drives.

(3) A thermal overload relay can be added. The contact on this relay must then be integrated in the control circuit.



### Drives powered by external DC power supply

ATV 61HD18M3X...HD45M3X, ATV 61D22N4...D75N4, ATV 61WD22N4C...WD75N4C and ATV 61HU30Y...HD90Y

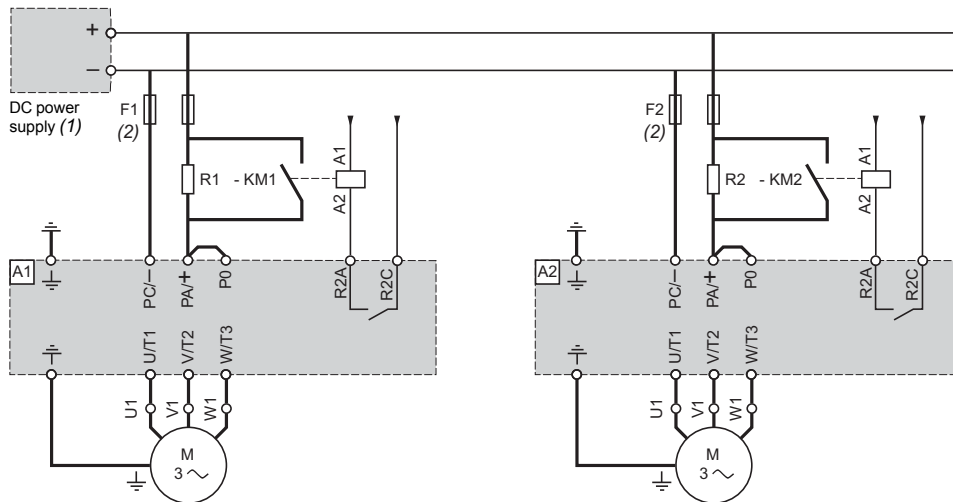

For drives A1, A2	Precharge resistors R1, R2		Contactors (3) KM1, KM2
	Value	Reference	
	Ω		
ATV 61HD18M3X	5	VW3 A7 707	LC1 D32●●
ATV 61HD22M3X	5	VW3 A7 707	LC1 D40●●
ATV 61HD30M3X	5	VW3 A7 707	LC1 D65●●
ATV 61HD37M3X	5	VW3 A7 707	LC1 D80●●
ATV 61HD45M3X	5	VW3 A7 707	LC1 D80●●
ATV 61HD22N4, WD22N4, WD22N4C	5	VW3 A7 707	LC1 D25●●
ATV 61HD30N4, WD30N4, WD30N4C	5	VW3 A7 707	LC1 D32●●
ATV 61HD37N4, WD37N4, WD37N4C	5	VW3 A7 707	LC1 D38●●
ATV 61HD45N4, WD45N4, WD45N4C	5	VW3 A7 707	LC1 D40●●
ATV 61HD55N4, WD55N4, WD55N4C	5	VW3 A7 707	LC1 D50●●
ATV 61HD75N4, WD75N4, WD75N4C	5	VW3 A7 707	LC1 D80●●
ATV 61HU30Y	8	VW3 A7 706	LC1 D09●●
ATV 61HU40Y	8	VW3 A7 706	LC1 D09●●
ATV 61HU55Y	8	VW3 A7 706	LC1 D12●●
ATV 61HU75Y	8	VW3 A7 706	LC1 D12●●
ATV 61HD11Y	8	VW3 A7 706	LC1 D18●●
ATV 61HD15Y	8	VW3 A7 706	LC1 D18●●
ATV 61HD18Y	8	VW3 A7 706	LC1 D25●●
ATV 61HD22Y	8	VW3 A7 706	LC1 D32●●
ATV 61HD30Y	8	VW3 A7 706	LC1 D32●●
ATV 61HD37Y	8	VW3 A7 706	LC1 D40●●
ATV 61HD45Y	8	VW3 A7 706	LC1 D40●●
ATV 61HD55Y	8	VW3 A7 706	LC1 D65●●
ATV 61HD75Y	8	VW3 A7 706	LC1 D65●●
ATV 61HD90Y	8	VW3 A7 706	LC1 D80●●

(1) DC power supply not included.

(2) Fast-acting semi-conductor fuses, see page 225. The function of the fuses is to protect the DC bus wiring in the event of a drive short-circuit.

(3) See our catalogue "Motor starter solutions. Control and protection components".

**Note:** ATV 61H●●●M3, ATV 61HD11M3X, HD15M3X, ATV 61D075N4...D18N4 and ATV 61W075N4C...WD18N4C drives have an integrated pre-charge circuit. This is used to connect the DC power supply directly to the drive without the need for an external pre-charge circuit.

### Connection schemes for several drives in parallel on the DC bus

#### Drives with different ratings

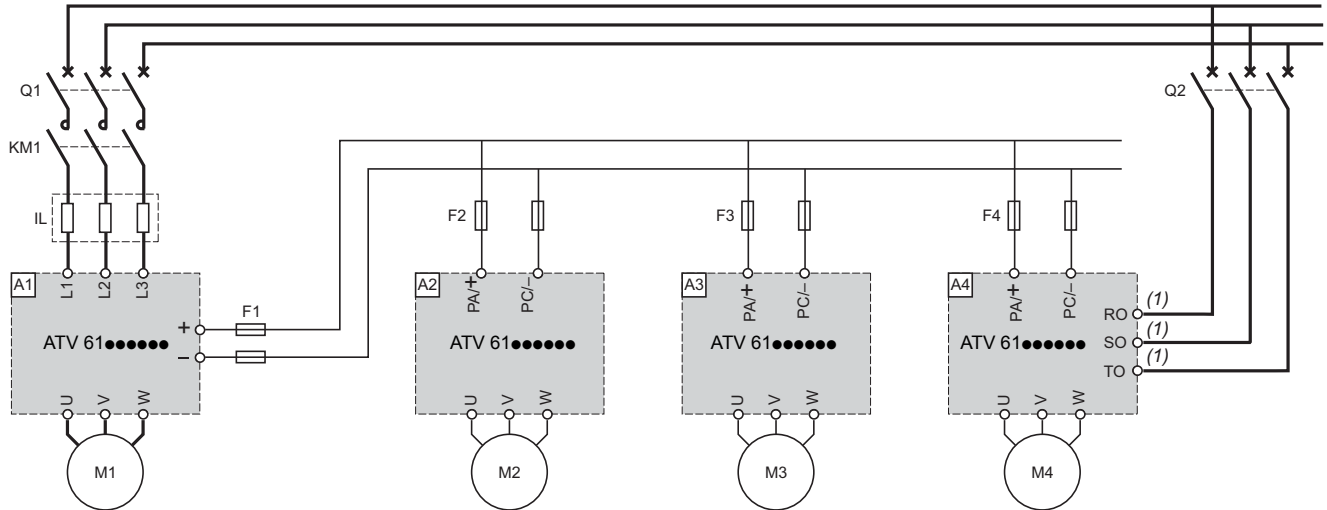

Ref.	Description
A1	ATV 61 drive, see pages 20 to 25. Drive power = $\sum$ motor power ratings M1 + M2 + M3 + M4 + ...
A2, A3, A4	ATV 61 drives powered by the DC bus. They must be protected using fast-acting semi-conductor fuses. Contactors on the DC circuit are ineffective as the switching action may cause the fuses to blow owing to the high load current.
F1	Fast-acting semi-conductor fuses, see page 225. Drive A1 powered by the AC supply with an output bus. The function of the fuse is to protect the internal diode bridge in the event of a short-circuit on the external DC bus.
F2, F3, F4	Fast-acting semi-conductor fuses, see page 225. Drives A2, A3 and A4 are powered by their DC bus and are not connected to the AC input. The function of the fuses is to protect the DC bus wiring in the event of a drive short-circuit.
IL	Line chokes mandatory for ATV 61HC25Y...HC80Y drives; to be ordered separately, see page 154.
KM1	Line contactors Rating: see motor starters on pages 229 to 239.
Q1	Circuit-breakers Rating: see motor starters on pages 229 to 239.

(1) For ATV 61HD90M3X and ATV 61HC11N4...HC63N4 drives, provide the fan power supply connection.

### Connection schemes for several drives in parallel on the DC bus (continued)

#### Drives with equivalent ratings

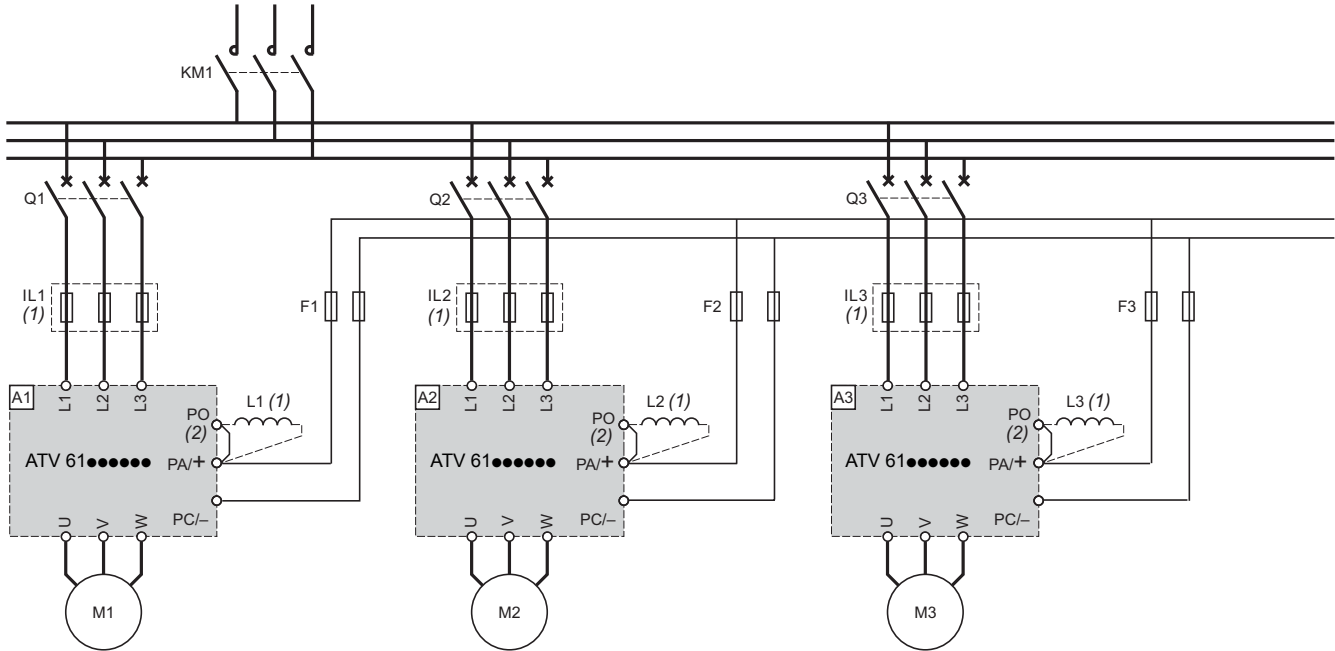

Ref.	Description
A1, A2, A3	ATV 61 drives, see pages 20 to 25. The power difference between the drives connected in parallel must not exceed one rating.
F1, F2, F3	Fast-acting semi-conductor fuses, see page 225. Drives A1, A2 and A3 powered by the AC supply with an output bus. The function of the fuse is to protect the internal diode bridge in the event of a short-circuit on the external DC bus.
KM1	When using a common line contactor, all the Altivar 61 drive load circuits operate in parallel and cannot therefore be overloaded.
IL1, IL2, IL3 (1)	Line chokes mandatory for ATV 61H●●●Y drives, to be ordered separately, see page 154.
L1, L2, L3 (1)	DC chokes mandatory except for ATV 61HD55M3X...HD90M3X and ATV 61HD90N4...HC63N4 drives which include a DC choke as standard, see page 149. Not used for ATV 61H●●●Y drives, which require the presence of line chokes IL●.
Q1, Q2, Q3	Circuit-breakers on the line supply side to protect drives against overloads. Use trip contacts on the "external fault" logic input or the line contactor. The line contactor must only be activated if all three circuit-breakers are closed, as otherwise there is a risk of damage to the drives.

(1) The use of line chokes or DC chokes depends on the drive type, see table above.

(2) There is no PO terminal on ATV 61HC11Y...HC80Y drives.

### Size of DC bus fuses (F1, F2, F3, F4) depending on the drive rating

For drives	Fast-acting semi-conductor fuses (1)
	<b>A</b>
ATV 61H075M3	10
ATV 61HU15M3, HU22M3	16
ATV 61HU30M3	25
ATV 61HU40M3, HU55M3	40
ATV 61HU75M3	50
ATV 61HD11M3X	80
ATV 61HD15M3X	100
ATV 61HD18M3X	125
ATV 61HD22M3X	160
ATV 61HD30M3X	200
ATV 61HD37M3X	250
ATV 61HD45M3X	315
ATV 61HD55M3X	350
ATV 61HD75M3X	500
ATV 61HD90M3X	630
ATV 61H075N4...HU22N4, ATV 61W075N4...WU22N4, ATV 61W075N4C...WU22N4C	10
ATV 61HU30N4, HU40N4, ATV 61WU30N4, WU40N4, ATV 61WU30N4C, WU40N4C	16
ATV 61HU55N4, ATV 61WU55N4, ATV 61WU55N4C	25
ATV 61HU75N4, HD11N4, ATV 61WU75N4, WD11N4, ATV 61WU75N4C, WD11N4C	40
ATV 61HD15N4...HD22N4, ATV 61WD15N4...WD22N4, ATV 61WD15N4C...WD22N4C	80
ATV 61HD30N4, HD37N4, ATV 61WD30N4, WD37N4, ATV 61WD30N4C, WD37N4C	125
ATV 61HD45N4, ATV 61WD45N4, ATV 61WD45N4C	160
ATV 61HD55N4, ATV 61WD55N4, ATV 61WD55N4C	200
ATV 61HD75N4, HD90N4, ATV 61WD75N4, WD90N4, ATV 61WD75N4C, WD90N4C	315
ATV 61HC11N4	400
ATV 61HC13N4	500
ATV 61HC16N4	550
ATV 61HC22N4	800
ATV 61HC25N4	900
ATV 61HC31N4	1100
ATV 61HC40N4	1400
ATV 61HC50N4	1800
ATV 61HC63N4	2250
ATV 61HU30Y...HU75Y	25
ATV 61HD11Y...HD18Y	40
ATV 61HD22Y...HD37Y	63
ATV 61HD45Y...HD75Y	125
ATV 61HD90Y, HC11Y	200
ATV 61HC13Y	250
ATV 61HC16Y	315
ATV 61HC20Y	350
ATV 61HC25Y	450
ATV 61HC31Y	630
ATV 61HC40Y	800
ATV 61HC50Y	900
ATV 63HC63Y	1250
ATV 63HC80Y	1500

(1) Nominal voltage of fast-acting semi-conductor fuse:

Line supply voltage	Nominal voltage of fast-acting fuse
V ~	V
230, 400	690
440, 460, 480	800
500, 600, 690	1000

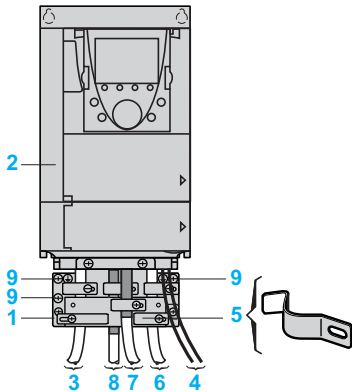

ATV 61H●●●M3, ATV 61HD11M3X, HD15M3X,  
ATV 61H075N4...HD18N4

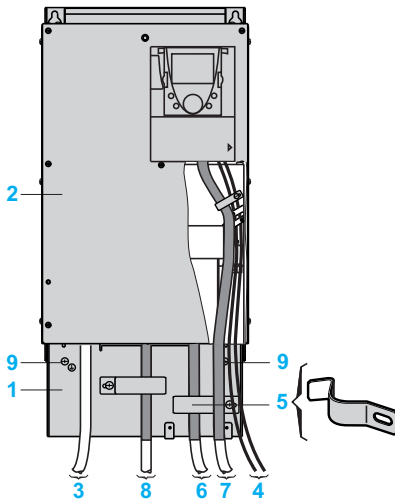

ATV 61HD18M3X...HD45M3X,  
ATV 61HD22N4...HD75N4  
ATV 61HU30Y...HD90Y

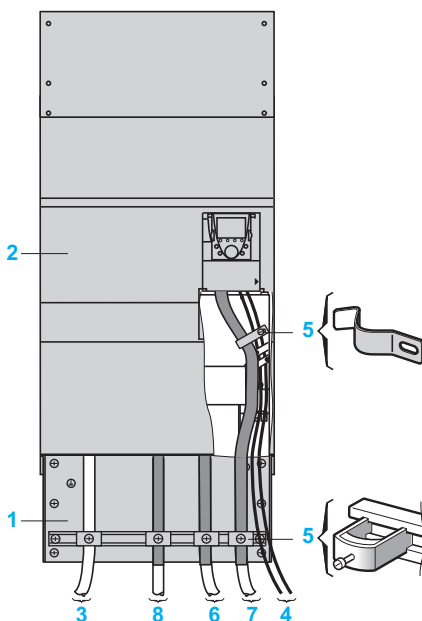

ATV 61HD55M3X...HD90M3X,  
ATV 61HD90N4...HC63N4  
ATV 61HC11Y...HC80Y

### Connections for ensuring conformity to EMC standards

#### Principle

- Earths between drive, motor and cable shielding must have "high frequency" equipotentiality.
- Use shielded cables with shielding connected to earth over 360° at both ends for the motor cable, the braking resistor cable and the control-signalling cables. Conduit or metal ducting can be used for part of the shielding length provided that there is no break in the continuity of the earth connections.
- Ensure maximum separation between the power supply cable (line supply) and the motor cable.

#### Installation diagram for ATV 61H●●●M3, ATV 61H●●●M3X, ATV 61H●●●N4 and ATV 61H●●●Y drives

- 1 Steel plate (1), to be mounted on the drive (earthed casing).
- 2 Altivar 61 UL Type 1/IP 20 drive.
- 3 Unshielded power supply wires or cable.
- 4 Unshielded wires for the output of the fault relay contacts.
- 5 Fix and earth the shielding of cables 6, 7 and 8 as close as possible to the drive:
  - strip the shielding
  - fix the cable to the plate 1 by attaching the clamp to the stripped part of the shielding.
 The shielding must be clamped tightly enough to the metal plate to ensure good contact.
- 6 Shielded cable for motor connection.
- 7 Shielded cable for connecting the control-signal section.
  - For applications requiring several conductors, use cables with a small cross-section (0.5 mm<sup>2</sup>).
- 8 Shielded cable for connecting the braking resistor.
  - 6, 7, 8, the shielding must be connected to earth at both ends. The shielding must be continuous, and if intermediate terminals are used, they must be placed in EMC shielded metal boxes.
- 9 Earth screw.

**Note:** The HF equipotential earth connection between the drive, motor and cable shielding does not remove the need to connect the PE protective conductors (green-yellow) to the appropriate terminals on each unit.

If using an additional EMC input filter, it should be mounted beneath the drive and connected directly to the line supply via an unshielded cable. Link 3 on the drive is then made by the filter output cable.

(1) Plate supplied for ATV 61H●●●M3, ATV 61HD11M3X...HD45M3X, ATV 61H075N4...HD75N4 and ATV 61HU30Y...HD90Y drives.

For ATV 61HD55M3X...HD90M3X, ATV 61HD90N4...HC31N4 and ATV 61HC11Y...HC40Y drives, the plate is supplied with the UL Type 1 conformity kit or the IP 21 or IP 31 conformity kit, to be ordered separately, see pages 30 and 31

For ATV 61HC40N4...HC63N4 and ATV 61HC50Y...HC80Y drives, the plate is supplied with the IP 31 conformity kit, to be ordered separately, see page 31.

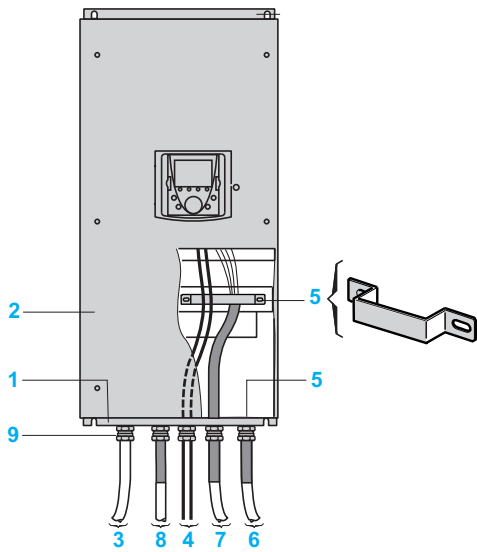

ATV 61W075N4...WD30N4,  
ATV 61W075N4C...WD30N4C

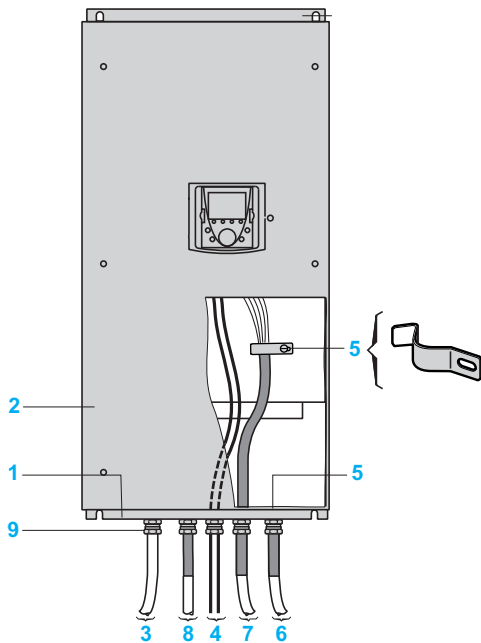

ATV 61WD37N4...WD90N4,  
ATV 61WD37N4C...WD90N4C

### Connections for ensuring conformity to EMC standards (continued)

#### Installation diagram for ATV 61W●●●N4, ATV 61W●●●N4C

- 1 Steel plate (earthed casing).
- 2 Altivar 61 UL Type 12/IP 54 drive.
- 3 Unshielded power supply wires or cable.
- 4 Unshielded wires for the output of the fault relay contacts.
- 5 Fix and earth the shielding of cables 6, 7 and 8 as close as possible to the drive:
  - strip the shielding
  - attach the shielded cable to the cable gland 9 ensuring it is fully in contact throughout 360°
  - fold back the shielding and clamp it between the ring and the body of the cable gland
 Depending on the drive rating, the shielding of cable 7 can be earthed using a cable gland 9, a clamp 5 or a cable clip 5. The shielding must be clamped tightly enough to the metal plate to ensure good contact.
- 6 Shielded cable for motor connection.
- 7 Shielded cable for connecting the control-signal section. For applications requiring several conductors, use cables with a small cross-section (0.5 mm<sup>2</sup>).
- 8 Shielded cable for connecting the braking resistor.
  - 6, 7, 8, the shielding must be connected to earth at both ends. The shielding must be continuous, and if intermediate terminals are used, they must be placed in EMC shielded metal boxes.
- 9 Metal cable gland (not supplied) for cables 6, 7 and 8.  
Standard cable gland (not supplied) for cables 3 and 4.

**Note:** The HF equipotential earth connection between the drive, motor and cable shielding does not remove the need to connect the PE protective conductors (green-yellow) to the appropriate terminals on each unit.

If using an additional EMC input filter, it should be mounted next to the drive and connected directly to the line supply via an unshielded cable. Link 3 on the drive is then made by the filter output cable.

DF534567



DF534568



PF107484



GV2 L20  
+  
LC1 D25●●  
+  
ATV 61HU22M3

### Applications

Circuit-breaker/contactor/drive combinations can be used to ensure continuous service of the installation with optimum safety.

The type of circuit-breaker/contactor coordination selected can reduce maintenance costs in the event of a motor short-circuit by minimizing the time required to make the necessary repairs and the cost of replacement equipment. The suggested combinations provide type 1 or type 2 coordination depending on the drive rating.

**Type 2 coordination:** A motor short-circuit will not damage the device or affect its settings. The motor starter should be able to operate once the electrical fault has been removed. The electrical isolation provided by the circuit-breaker will not be affected by the short-circuit. Welding of the contactor contacts is permissible if they can be separated easily.

**Type 1 coordination:** The electrical isolation provided by the circuit-breaker will not be affected by the incident and no other elements apart from the contactor are damaged as a result of the motor short-circuit.

The drive controls the motor, provides protection against short-circuits between the drive and the motor and protects the motor cable against overloads. The overload protection is provided by the drive's motor thermal protection. If this protection is removed, external thermal protection should be provided. Before restarting the installation, the cause of the trip must be removed.

### Motor starters for UL Type 1/IP 20 drives

Motor Power (1) kW      HP	Drive Reference	Circuit-breaker		Line contactor		
		Reference (2)	Rating A	I <sub>rm</sub> A	Reference (3) (4)	
<b>Single-phase supply voltage: 200...240 V 50/60 Hz. Type 2 coordination</b>						
0.37	0.5	ATV 61H075M3	GV2 L14	10	–	LC1 D09●●
0.75	1	ATV 61HU15M3	GV2 L16	14	–	LC1 D18●●
1.5	2	ATV 61HU22M3	GV2 L20	18	–	LC1 D25●●
2.2	3	ATV 61HU30M3	GV2 L32	32	–	LC1 D32●●
			NS80HMA50	50	300	LC1 D32●●
3	–	ATV 61HU40M3 (5)	GV2 L32	32	–	LC1 D32●●
			NS80HMA50	50	300	LC1 D32●●
4	5	ATV 61HU55M3 (5)	GV3 L40	50	–	LC1 D40●●
5.5	7.5	ATV 61HU75M3 (5)	GV3 L50	50	–	LC1 D50●●
				–	–	–
<b>Single-phase supply voltage: 200...240 V 50/60 Hz. Type 1 coordination</b>						
0.37	0.5	ATV 61H075M3	GV2 LE14	10	–	LC1 K06●●
0.75	1	ATV 61HU15M3	GV2 LE16	14	–	LC1 K06●●
1.5	2	ATV 61HU22M3	GV2 LE20	18	–	LC1 K06●●
2.2	3	ATV 61HU30M3	GV2 LE32	32	–	LC1 D18●●
3	–	ATV 61HU40M3 (5)	GV2 LE32	32	–	LC1 D18●●
			–	–	–	–
4	5	ATV 61HU55M3 (5)	NS80HMA50	50	300	LC1 D40●●
			–	–	–	–
5.5	7.5	ATV 61HU75M3 (5)	NS80HMA50	50	300	LC1 D40●●
			–	–	–	–

(1) Standard power ratings for 4-pole motors 230 V 50/60 Hz.  
The values expressed in HP comply with the NEC (National Electrical Code).

(2) NS80HMA: Product sold under the Merlin Gerin brand.  
Breaking capacity of circuit-breakers according to standard IEC 60947-2:

Circuit-breaker	I <sub>cu</sub> (kA) for 240 V
GV2 L14, GV2 L16, GV2 LE14...GV2 LE20	100
GV2 L20, GV2 L32, GV2 LE32	50
GV3 L, NS80HMA	100

(3) Composition of contactors:  
LC1 K06: 3 poles + 1 "N/O" auxiliary contact and 1 "N/C" auxiliary contact.

LC1 D●●: 3 poles + 1 "N/O" auxiliary contact and 1 "N/C" auxiliary contact.

(4) Replace ●● with the control circuit voltage reference indicated in the table below:

	Volts ~	24	48	110	220	230	240
LC1 K06	50/60 Hz	B7	E7	F7	M7	P7	U7
LC1 D●●	50 Hz	B5	E5	F5	M5	P5	U5
	60 Hz	B6	E6	F6	M6	–	U6
	50/60 Hz	B7	E7	F7	M7	P7	U7

For other voltages available between 24 V and 660 V, or a DC control circuit, please consult your Regional Sales Office.

(5) A line choke must be added (see page 154).

DF534570



DF534588



PF107485



GV2 L22  
+  
LC1 D25●●  
+  
ATV 61HU30M3

**Motor starters for UL Type 1/IP 20 drives**

Motor		Drive	Circuit-breaker		Line contactor	
Power (1)		Reference	Reference (2)	Rating I <sub>rm</sub>		Reference (3) (4)
kW	HP			A	A	
<b>Three-phase supply voltage: 200...240 V 50/60 Hz. Type 2 coordination</b>						
0.75	1	ATV 61H075M3	GV2 L10	6.3	–	LC1 D09●●
1.5	2	ATV 61HU15M3	GV2 L16	14	–	LC1 D18●●
2.2	3	ATV 61HU22M3	GV2 L20	18	–	LC1 D18●●
3	–	ATV 61HU30M3	GV2 L22	25	–	LC1 D25●●
4	5	ATV 61HU40M3	GV2 L32	32	–	LC1 D40●●
5.5	7.5	ATV 61HU55M3	GV3 L40	40	–	LC1 D40●●
7.5	10	ATV 61HU75M3	GV3 L50	50	–	LC1 D50●●
11	15	ATV 61HD11M3X	GV3 L65	65	–	LC1 D65●●
15	20	ATV 61HD15M3X	NS80HMA80	80	480	LC1 D80●●
18.5	25	ATV 61HD18M3X	NS80HMA80	80	480	LC1 D80●●
22	30	ATV 61HD22M3X	NS100●MA100	100	600	LC1 D115●●
30	40	ATV 61HD30M3X	NS160●MA150	150	1350	LC1 D115●●
37	50	ATV 61HD37M3X	NS160●MA150	150	1350	LC1 D150●●
45	60	ATV 61HD45M3X	NS250●MA220	220	1980	LC1 F185●●
55	75	ATV 61HD55M3X	NS250●MA220	220	1980	LC1 F225●●
75	100	ATV 61HD75M3X	NS400●MA320	320	1920	LC1 F265●●
90	125	ATV 61HD90M3X	NS630●MAE500	500	3000	LC1 F330●●
<b>Three-phase supply voltage: 200...240 V 50/60 Hz. Type 1 coordination</b>						
0.75	1	ATV 61H075M3	GV2 LE10	6.3	–	LC1 K06●●
1.5	2	ATV 61HU15M3	GV2 LE16	14	–	LC1 K06●●
2.2	3	ATV 61HU22M3	GV2 LE20	18	–	LC1 K06●●
3	–	ATV 61HU30M3	GV2 LE22	25	–	LC1 K06●●
4	5	ATV 61HU40M3	GV2 LE32	32	–	LC1 D18●●
5.5	7.5	ATV 61HU55M3	NS80HMA50	50	300	LC1 D25●●
7.5	10	ATV 61HU75M3	NS80HMA50	50	300	LC1 D32●●
11	15	ATV 61HD11M3X	NS80HMA80	80	480	LC1 D40●●
15	20	ATV 61HD15M3X	NS80HMA80	80	480	LC1 D50●●
18.5	25	ATV 61HD18M3X	NS80HMA80	80	480	LC1 D50●●
22	30	ATV 61HD22M3X	NS100●MA100	100	600	LC1 D80●●
30	40	ATV 61HD30M3X	NS160●MA150	150	1350	LC1 D80●●
37	50	ATV 61HD37M3X	NS160●MA150	150	1350	LC1 D115●●
45	60	ATV 61HD45M3X	NS250●MA220	220	1320	LC1 D115●●
55	75	ATV 61HD55M3X	NS250●MA220	220	1980	LC1 D115●●
75	100	ATV 61HD75M3X	NS400●MA320	320	1920	LC1 F185●●
90	125	ATV 61HD90M3X	NS630●MAE500	500	3000	LC1 F265●●

(1) Standard power ratings for 4-pole motors 230 V 50/60 Hz.  
The values expressed in HP comply with the NEC (National Electrical Code).  
(2) NS80HMA●●, NS●●●●MA: Products sold under the Merlin Gerin brand.  
Breaking capacity of circuit-breakers according to standard IEC 60947-2:

Circuit-breaker	I <sub>cu</sub> (kA) for 240 V			
		N	H	L
GV2 L10...L20, GV2 LE10...LE20, GV3 L40...L65	100	–	–	–
GV2 L22, GV2 L32, GV2 LE22, GV2 LE32	50	–	–	–
NS80HMA	100	–	–	–
NS●●●●MA	–	85	100	150

(3) Composition of contactors:  
LC1 K06: 3 poles + 1 "N/O" auxiliary contact and 1 "N/C" auxiliary contact.  
LC1 D●●: 3 poles + 1 "N/O" auxiliary contact + 1 "N/C" auxiliary contact.  
LC1 F●●●: 3 poles. To add auxiliary contacts or other accessories, please refer to the "Motor starter solutions. Control and protection components" catalogue.  
(4) Replace ●● with the control circuit voltage reference indicated in the table below:

	Volts ~	24	48	110	220	230	240
LC1 K06	50/60 Hz	B7	E7	F7	M7	P7	U7
LC1 D09...D150	50 Hz	B5	E5	F5	M5	P5	U5
	60 Hz	B6	E6	F6	M6	–	U6
	50/60 Hz	B7	E7	F7	M7	P7	U7
LC1 F185, LC1 F225	50 Hz (LX1 coil)	B5	E5	F5	M5	P5	U5
	60 Hz (LX1 coil)	–	E6	F6	M6	–	U6
	40...400 Hz (LX9 coil)	–	E7	F7	M7	P7	U7
LC1 F265, LC1 F330	40...400 Hz (LX1 coil)	B7	E7	F7	M7	P7	U7

For other voltages available between 24 V and 660 V, or a DC control circuit, please consult your Regional Sales Office.



DF534573



DF534574



PF537422



NS160●MA150  
+  
LC1 D115●●  
+  
ATV 61HD55N4

**Motor starters for UL Type 1/IP 20 drives**

Motor		Drive	Circuit-breaker	Line contactor		
Power (1)		Reference	Reference (2)	Rating	I <sub>rm</sub>	Reference (3) (4)
kW	HP			A	A	
<b>Three-phase supply voltage: 380...415 V 50/60 Hz. Type 2 coordination</b>						
0.75	1	ATV 61HU075N4	GV2 L08	4	–	LC1 D09●●
1.5	2	ATV 61HU15N4	GV2 L10	6.3	–	LC1 D09●●
2.2	3	ATV 61HU22N4	GV2 L14	10	–	LC1 D09●●
3	–	ATV 61HU30N4	GV2 L16	14	–	LC1 D18●●
4	5	ATV 61HU40N4	GV2 L16	14	–	LC1 D18●●
5.5	7.5	ATV 61HU55N4	GV2 L22	25	–	LC1 D25●●
7.5	10	ATV 61HU75N4	GV3 L32	32	–	LC1 D40●●
11	15	ATV 61HD11N4	GV3 L40	40	–	LC1 D40●●
15	20	ATV 61HD15N4	GV3 L50	50	–	LC1 D40●●
18.5	25	ATV 61HD18N4	GV3 L50	50	–	LC1 D50●●
22	30	ATV 61HD22N4	GV3 L65	65	–	LC1 D65●●
30	40	ATV 61HD30N4	NS80HMA80	80	480	LC1 D65●●
37	50	ATV 61HD37N4	NS80HMA80	80	480	LC1 D80●●
45	60	ATV 61HD45N4	NS100●MA100	100	600	LC1 D115●●
55	75	ATV 61HD55N4	NS160●MA150	150	1350	LC1 D115●●
75	100	ATV 61HD75N4	NS250●MA220	220	1980	LC1 F185●●
90	125	ATV 61HD90N4	NS250●MA220	220	1980	LC1 F185●●
110	150	ATV 61HC11N4	NS250●MA220	220	1980	LC1 F225●●
132	200	ATV 61HC13N4	NS250●MA220	220	1980	LC1 F265●●
160	250	ATV 61HC16N4	NS400●MA320	320	1920	LC1 F330●●
200	300	ATV 61HC22N4	NS630●MAE500	500	3000	LC1 F400●●
220	350	ATV 61HC22N4	NS630●MAE500	500	3000	LC1 F400●●
250	400	ATV 61HC25N4	NS630●MAE500	500	3000	LC1 F500●●
280	450	ATV 61HC31N4	NS630●MAE500	500	3000	LC1 F500●●
315	500	ATV 61HC31N4	NS800L Micrologic 2 or 5 (LR OFF)	800	1600	LC1 F630●●
355	–	ATV 61HC40N4	NS800L Micrologic 2 or 5 (LR OFF)	800	1600	LC1 F630●●
400	600	ATV 61HC40N4	NS800L Micrologic 2 or 5 (LR OFF)	800	1600	LC1 F630●●
500	700	ATV 61HC50N4	NS1000L Micrologic 2 or 5 (LR OFF)	1000	2000	LC1 F630●●
560	800	ATV 61HC63N4	NS1000L Micrologic 2 or 5 (LR OFF)	1000	2000	LC1 F780●●

(1) Standard power ratings for 4-pole motors 400 V 50/60 Hz.

The values expressed in HP comply with the NEC (National Electrical Code).

(2) NS80HMA●●, NS●●●●: Products sold under the Merlin Gerin brand.

For references to be completed, replace the dot with the letter corresponding to the circuit-breaker breaking performance (N, H, L).

Breaking capacity of circuit-breakers according to standard IEC 60947-2:

Circuit-breaker	I <sub>cu</sub> (kA) for 400 V	I <sub>cu</sub> (kA) for 400 V		
		N	H	L
GV2 L08...L14, GV3 L32	100	–	–	–
GV2 L16...L22, GV3 L40...L65	50	–	–	–
NS80HMA	70	–	–	–
NS100●MA	–	25	70	150
NS160●MA, NS250●MA	–	36	70	150
NS400●MA, NS630●MAE	–	45	70	150
NS800L Micrologic 2 or 5, NS1000L Micrologic 2 or 5	–	–	–	150

(3) Composition of contactors:

LC1 D●●: 3 poles + 1 "N/O" auxiliary contact + 1 "N/C" auxiliary contact.

LC1 F●●●: 3 poles. To add auxiliary contacts or other accessories, please refer to the "Motor starter solutions. Control and protection components" catalogue.

(4) Replace ●● with the control circuit voltage reference indicated in the table below:

LC1 D09...D115	Volts ~	24	48	110	220	230	240
	50 Hz	B5	E5	F5	M5	P5	U5
60 Hz	B6	E6	F6	M6	–	U6	
50/60 Hz	B7	E7	F7	M7	P7	U7	
LC1 F185, LC1 F225	50 Hz (LX1 coil)	B5	E5	F5	M5	P5	U5
	60 Hz (LX1 coil)	–	E6	F6	M6	–	U6
	40...400 Hz (LX9 coil)	–	E7	F7	M7	P7	U7
LC1 F265, F330	40...400 Hz (LX1 coil)	B7	E7	F7	M7	P7	U7
LC1 F400...F630	40...400 Hz (LX1 coil)	–	E7	F7	M7	P7	U7
LC1 F780	40...400 Hz (LX1 coil)	–	–	F7	P7	P7	P7

For other voltages available between 24 V and 660 V, or a DC control circuit, please consult your Regional Sales Office.

DF534873



DF534832



PF537422



NS160●MA150  
+  
LC1 D115●●  
+  
ATV 61HD55N4

### Motor starters for UL Type 1/IP 20 drives

Motor		Drive	Circuit-breaker	Line contactor		
Power (1)	Reference	Reference (2)	Rating	I <sub>rm</sub>	Reference (3) (4)	
kW	HP		A	A		
<b>Three-phase supply voltage: 380...415 V 50/60 Hz. Type 1 coordination</b>						
0.75	1	ATV 61HU75N4	GV2 LE08	4	–	LC1 K06●●
1.5	2	ATV 61HU15N4	GV2 LE10	6.3	–	LC1 K06●●
2.2	3	ATV 61HU22N4	GV2 LE14	10	–	LC1 K06●●
3	–	ATV 61HU30N4	GV2 LE16	14	–	LC1 K06●●
4	5	ATV 61HU40N4	GV2 LE16	14	–	LC1 K06●●
5.5	7.5	ATV 61HU55N4	GV2 LE22	25	–	LC1 D09●●
7.5	10	ATV 61HU75N4	GV2 LE32	32	–	LC1 D18●●
11	15	ATV 61HD11N4	NS80HMA50	50	300	LC1 D25●●
15	20	ATV 61HD15N4	NS80HMA50	50	300	LC1 D32●●
18.5	25	ATV 61HD18N4	NS80HMA50	50	300	LC1 D32●●
22	30	ATV 61HD22N4	NS80HMA80	50	300	LC1 D32●●
30	40	ATV 61HD30N4	NS80HMA80	80	480	LC1 D50●●
37	50	ATV 61HD37N4	NS80HMA80	80	480	LC1 D80●●
45	60	ATV 61HD45N4	NS100●MA100	100	600	LC1 D80●●
55	75	ATV 61HD55N4	NS160●MA150	150	1350	LC1 D80●●
75	100	ATV 61HD75N4	NS250●MA220	220	1980	LC1 D115●●
90	125	ATV 61HD90N4	NS250●MA220	220	1980	LC1 D115●●
110	150	ATV 61HC11N4	NS250●MA220	220	1980	LC1 F150●●
132	200	ATV 61HC13N4	NS250●MA220	220	1980	LC1 F150●●
160	250	ATV 61HC16N4	NS400●MA320	320	1920	LC1 F225●●
200	300	ATV 61HC22N4	NS630●MAE500	500	3000	LC1 F330●●
220	350	ATV 61HC22N4	NS630●MAE500	500	3000	LC1 F330●●
250	400	ATV 61HC25N4	NS630●MAE500	500	3000	LC1 F400●●
280	450	ATV 61HC31N4	NS630●MAE500	500	3000	LC1 F400●●
315	500	ATV 61HC31N4	NS800 Micrologic 2 or 5 (LR OFF)	800	1600	LC1 F500●●
355	–	ATV 61HC40N4	NS800 MicroLogic 2 or 5 (LR OFF)	800	1600	LC1 F500●●
400	600	ATV 61HC40N4	NS800 MicroLogic 2 or 5 (LR OFF)	800	1600	LC1 F630●●
500	700	ATV 61HC50N4	NS1000 MicroLogic 2 or 5 (LR OFF)	1000	2000	LC1 F630●●
560	800	ATV 61HC63N4	NS1000 MicroLogic 2 or 5 (LR OFF)	1000	2000	LC1 F630●●
630	900	ATV 61HC63N4	NS1250 MicroLogic 2 or 5 (LR OFF)	1000	2000	LC1 F630●●S011

(1) Standard power ratings for 4-pole motors 400 V 50/60 Hz.

The values expressed in HP comply with the NEC (National Electrical Code).

(2) NS80HMA●●, NS●●●●: Products sold under the Merlin Gerin brand.

For references to be completed, replace the dot with the letter corresponding to the circuit-breaker breaking performance (N, H, L).  
Breaking capacity of circuit-breakers according to standard IEC 60947-2:

Circuit-breaker	Icu (kA) for 400 V			
		N	H	L
GV2 LE08...LE22	15	–	–	–
GV2 LE32	10	–	–	–
NS80HMA	70	–	–	–
NS100●MA	–	25	70	150
NS160●MA, NS250●MA	–	36	70	150
NS400●MA, NS630●MAE	–	45	70	150
NS800, NS1000, NS1250	–	50	70	–

(3) Composition of contactors:

LC1 K06: 3 poles + 1 "N/O" auxiliary contact + 1 "N/C" auxiliary contact.

LC1 D●●: 3 poles + 1 "N/O" auxiliary contact + 1 "N/C" auxiliary contact.

LC1 F●●: 3 poles. To add auxiliary contacts or other accessories, please refer to the "Motor starter solutions. Control and protection components" catalogue.

(4) Replace ●● with the control circuit voltage reference indicated in the table below:

	Volts ~	24	48	110	220	230	240
LC1 K06	50/60 Hz	B7	E7	F7	M7	P7	U7
LC1 D09...D115	50 Hz	B5	E5	F5	M5	P5	U5
	60 Hz	B6	E6	F6	M6	–	U6
LC1 F150, LC1 F225	50/60 Hz	B7	E7	F7	M7	P7	U7
	50 Hz (LX1 coil)	B5	E5	F5	M5	P5	U5
	60 Hz (LX1 coil)	–	E6	F6	M6	–	U6
LC1 F330	40...400 Hz (LX9 coil)	–	E7	F7	M7	P7	U7
	40...400 Hz (LX1 coil)	B7	E7	F7	M7	P7	U7
LC1 F400...F630	40...400 Hz (LX1 coil)	–	E7	F7	M7	P7	U7

For other voltages available between 24 V and 660 V, or a DC control circuit, please consult your Regional Sales Office.

DF534573



DF534574



PF107492



NS160●MA150  
+  
LC1 D115●●  
+  
ATV 61WD55N4

**Motor starters for UL Type 12/IP 54 drives**

Motor		Drive	Circuit-breaker	Line contactor		
Power (1)	Reference	Reference (2)	Rating	I <sub>rm</sub>	Reference (3) (4)	
kW	HP		A	A		
<b>Three-phase supply voltage: 380...415 V 50/60 Hz. Type 2 coordination</b>						
0.75	1	ATV 61W075N4 ATV 61W075N4C	GV2 L07	2.5	–	LC1 D09●●
1.5	2	ATV 61WU15N4 ATV 61WU15N4C	GV2 L08	4	–	LC1 D09●●
2.2	3	ATV 61WU22N4 ATV 61WU22N4C	GV2 L10	6.3	–	LC1 D09●●
3	–	ATV 61WU30N4 ATV 61WU30N4C	GV2 L14	10	–	LC1 D09●●
4	5	ATV 61WU40N4 ATV 61WU40N4C	GV2 L14	10	–	LC1 D09●●
5.5	7.5	ATV 61WU55N4 ATV 61WU55N4C	GV2 L16	14	–	LC1 D18●●
7.5	10	ATV 61WU75N4 ATV 61WU75N4C	GV3 L32	32	–	LC1 D40●●
11	15	ATV 61WD11N4 ATV 61WD11N4C	GV3 L40	40	–	LC1 D40●●
15	20	ATV 61WD15N4 ATV 61WD15N4C	GV3 L50	50	–	LC1 D50●●
18.5	25	ATV 61WD18N4 ATV 61WD18N4C	GV3 L50	50	–	LC1 D50●●
22	30	ATV 61WD22N4 ATV 61WD22N4C	GV3 L65	65	–	LC1 D65●●
30	40	ATV 61WD30N4 ATV 61WD30N4C	NS80HMA80	80	480	LC1 D65●●
37	50	ATV 61WD37N4 ATV 61WD37N4C	NS80HMA80	80	480	LC1 D80●●
45	60	ATV 61WD45N4 ATV 61WD45N4C	NS100●MA100	100	600	LC1 D80●●
55	75	ATV 61WD55N4 ATV 61WD55N4C	NS160●MA150	150	1350	LC1 D115●●
75	100	ATV 61WD75N4 ATV 61WD75N4C	NS160●MA150	150	1350	LC1 D115●●
90	125	ATV 61WD90N4 ATV 61WD90N4C	NS250●MA220	220	1980	LC1 F185●●

(1) Standard power ratings for 4-pole motors 400 V 50/60 Hz.

The values expressed in HP comply with the NEC (National Electrical Code).

(2) NS80HMA●●, NS●●●●: Products sold under the Merlin Gerin brand.

For references to be completed, replace the dot with the letter corresponding to the circuit-breaker breaking performance (N, H, L).  
Breaking capacity of circuit-breakers according to standard IEC 60947-2:

Circuit-breaker	I <sub>cu</sub> (kA) for 400 V			
	N	H	L	
GV2 L07...L14, GV3 L32	100	–	–	–
GV2 L16, GV3 L40...L65	50	–	–	–
NS80HMA	70	–	–	–
NS100●MA	–	25	70	150
NS160●MA, NS250●MA	–	36	70	150

(3) Composition of contactors:

LC1 D●●: 3 poles + 1 "N/O" auxiliary contact and 1 "N/C" auxiliary contact.

LC1 F185: 3 poles. To add auxiliary contacts or other accessories, please refer to the "Motor starter solutions. Control and protection components" catalogue.

(4) Replace ●● with the control circuit voltage reference indicated in the table below:

	Volts ~	24	48	110	220	230	240
		LC1 D09...D115	50 Hz	B5	E5	F5	M5
	60 Hz	B6	E6	F6	M6	–	U6
	50/60 Hz	B7	E7	F7	M7	P7	U7
LC1 F185	50 Hz (LX1 coil)	B5	E5	F5	M5	P5	U5
	60 Hz (LX1 coil)	–	E6	F6	M6	–	U6
	40...400 Hz (LX9 coil)	–	E7	F7	M7	P7	U7

For other voltages available between 24 V and 660 V, or a DC control circuit, please consult your Regional Sales Office.

DF534573



DF534574



PF107482



NS160●MA150  
+  
LC1 D115●●  
+  
ATV 61WD75N4

Motor starters for UL Type 12/IP 54 drives						
Motor		Drive	Circuit-breaker		Line contactor	
Power (1)		Reference	Reference (2)	Rating	I <sub>rm</sub>	Reference (3) (4)
kW	HP			A	A	
<b>Three-phase supply voltage: 380...415 V 50/60 Hz. Type 1 coordination</b>						
0.75	1	ATV 61W075N4 ATV 61W075N4C	GV2 LE07	2.5	–	LC1 K06●●
1.5	2	ATV 61WU15N4 ATV 61WU15N4C	GV2 LE08	4	–	LC1 K06●●
2.2	3	ATV 61WU22N4 ATV 61WU22N4C	GV2 LE10	6.3	–	LC1 K06●●
3	–	ATV 61WU30N4 ATV 61WU30N4C	GV2 LE14	10	–	LC1 K06●●
4	5	ATV 61WU40N4 ATV 61WU40N4C	GV2 LE14	10	–	LC1 K06●●
5.5	7.5	ATV 61WU55N4 ATV 61WU55N4C	GV2 LE16	14	–	LC1 K06●●
7.5	10	ATV 61WU75N4 ATV 61WU75N4C	GV2 LE20	18	–	LC1 K06●●
11	15	ATV 61WD11N4 ATV 61WD11N4C	GV2 LE22	25	–	LC1 D09●●
15	20	ATV 61WD15N4 ATV 61WD15N4C	GV2 LE32	32	–	LC1 D18●●
18.5	25	ATV 61WD18N4 ATV 61WD18N4C	NS80HMA50	50	300	LC1 D25●●
22	30	ATV 61WD22N4 ATV 61WD22N4C	NS80HMA50	50	300	LC1 D32●●
30	40	ATV 61WD30N4 ATV 61WD30N4C	NS80HMA80	80	480	LC1 D40●●
37	50	ATV 61WD37N4 ATV 61WD37N4C	NS80HMA80	80	480	LC1 D50●●
45	60	ATV 61WD45N4 ATV 61WD45N4C	NS100●MA100	100	600	LC1 D80●●
55	75	ATV 61WD55N4 ATV 61WD55N4C	NS160●MA150	150	1350	LC1 D80●●
75	100	ATV 61WD75N4 ATV 61WD75N4C	NS160●MA150	150	1350	LC1 D115●●
90	125	ATV 61WD90N4 ATV 61WD90N4C	NS250●MA220	220	1980	LC1 D115●●

(1) Standard power ratings for 4-pole motors 400 V 50/60 Hz.

The values expressed in HP comply with the NEC (National Electrical Code).

(2) NS80HMA●●, NS●●●●: Products sold under the Merlin Gerin brand.

For references to be completed, replace the dot with the letter corresponding to the circuit-breaker breaking performance (N, H, L).  
Breaking capacity of circuit-breakers according to standard IEC 60947-2:

Circuit-breaker	I <sub>cu</sub> (kA) for 400 V			
	N	H	L	
GV2 LE07...LE14	100	–	–	–
GV2 LE16...LE22	15	–	–	–
GV2 LE32	10	–	–	–
NS80HMA	70	–	–	–
NS100●MA	–	25	70	150
NS160●MA, NS250●MA	–	36	70	150

(3) Composition of contactors:

LC1 K06: 3 poles + 1 "N/O" auxiliary contact and 1 "N/C" auxiliary contact.

LC1 D●●: 3 poles + 1 "N/O" auxiliary contact and 1 "N/C" auxiliary contact.

Replace ●● with the control circuit voltage reference indicated in the table below:

	Volts ~	24	48	110	220	230	240
LC1 K06	50/60 Hz	B7	E7	F7	M7	P7	U7
LC1 D09...D115	50 Hz	B5	E5	F5	M5	P5	U5
	60 Hz	B6	E6	F6	M6	–	U6
	50/60 Hz	B7	E7	F7	M7	P7	U7

For other voltages available between 24 V and 660 V, or a DC control circuit, please consult your Regional Sales Office.

DF534673



DF534674



PF537422



NS160●MA150  
+  
LC1 D115●●  
+  
ATV 61HD75N4

Motor starters for UL Type 1/IP 20 drives

Motor		Drive	Circuit-breaker		Line contactor	
Power (1)	Reference	Reference (2)	Rating	I <sub>rm</sub>	Reference (3) (4)	
kW	HP		A	A		
<b>Three-phase supply voltage: 440...480 V 50/60 Hz. Type 2 coordination</b>						
0.75	1	ATV 61H075N4	GV2 L08	4	–	LC1 D09●●
1.5	2	ATV 61HU15N4	GV2 L10	6.3	–	LC1 D09●●
2.2	3	ATV 61HU22N4	GV2 L14	10	–	LC1 D09●●
3	–	ATV 61HU30N4	GV2 L14	10	–	LC1 D09●●
4	5	ATV 61HU40N4	GV2 L16	14	–	LC1 D18●●
5.5	7.5	ATV 61HU55N4	GV2 L20	18	–	LC1 D18●●
7.5	10	ATV 61HU75N4	GV2 L22	25	–	LC1 D25●●
11	15	ATV 61HD11N4	GV3 L32	32	–	LC1 D40●●
15	20	ATV 61HD15N4	GV3 L40	40	–	LC1 D40●●
18.5	25	ATV 61HD18N4	GV3 L50	50	–	LC1 D50●●
22	30	ATV 61HD22N4	GV3 L50	50	–	LC1 D50●●
30	40	ATV 61HD30N4	GV3 L65	65	480	LC1 D65●●
37	50	ATV 61HD37N4	NS80HMA80	80	480	LC1 D80●●
45	60	ATV 61HD45N4	NS100HMA100	100	600	LC1 D115●●
55	75	ATV 61HD55N4	NS100HMA100	100	600	LC1 D115●●
75	100	ATV 61HD75N4	NS160●MA150	150	1350	LC1 D115●●
90	125	ATV 61HD90N4	NS160●MA150	150	1350	LC1 D115●●
110	150	ATV 61HC11N4	NS250●MA220	220	1980	LC1 F185●●
132	200	ATV 61HC13N4	NS250●MA220	220	1980	LC1 F265●●
160	250	ATV 61HC16N4	NS400●MA320	320	1920	LC1 F330●●
200	300	ATV 61HC22N4	NS630●MAE500	500	3000	LC1 F330●●
220	350	ATV 61HC22N4	NS630●MAE500	500	3000	LC1 F400●●
250	400	ATV 61HC25N4	NS630●MAE500	500	3000	LC1 F500●●
280	450	ATV 61HC31N4	NS630●MAE500	500	3000	LC1 F500●●
315	500	ATV 61HC31N4	NS800L Micrologic 2 or 5 (LR OFF)	800	1600	LC1 F630●●
355	–	ATV 61HC40N4	NS800L Micrologic 2 or 5 (LR OFF)	800	1600	LC1 F630●●
400	600	ATV 61HC40N4	NS800L Micrologic 2 or 5 (LR OFF)	800	1600	LC1 F630●●
500	700	ATV 61HC50N4	NS1000L Micrologic 2 or 5 (LR OFF)	1000	2000	LC1 F630●●
560	800	ATV 61HC63N4	NS1000L Micrologic 2 or 5 (LR OFF)	1000	2000	LC1 F630●●
630	900	ATV 61HC63N4	NS1000L Micrologic 2 or 5 (LR OFF)	1000	2000	LC1 F630●●

(1) Standard power ratings for 4-pole motors 400 V 50/60 Hz.

The values expressed in HP comply with the NEC (National Electrical Code).

(2) NS80HMA●●, NS●●●●: Products sold under the Merlin Gerin brand.

For references to be completed, replace the dot with the letter corresponding to the circuit-breaker breaking performance (N, H, L).

Breaking capacity of circuit-breakers according to standard IEC 60947-2:

Circuit-breaker	I <sub>cu</sub> (kA) for 440 V	Icu (kA) for 440 V		
		N	H	L
GV2 L08, GV2 L10, GV3 L32	100	–	–	–
GV2 L14...L22	20	–	–	–
GV3 L40...L65	50	–	–	–
NS80HMA	65	–	–	–
NS100●MA	–	25	65	130
NS160●MA, NS250●MA	–	35	65	130
NS400●MA, NS630●MAE	–	42	65	130
NS800L Micrologic 2 or 5, NS1000L Micrologic 2 or 5	–	–	–	130

(3) Composition of contactors:

LC1 D●●: 3 poles + 1 "N/O" auxiliary contact + 1 "N/C" auxiliary contact.

LC1 F●●●: 3 poles. To add auxiliary contacts or other accessories, please refer to the "Motor starter solutions. Control and protection components" catalogue.

(4) Replace ●● with the control circuit voltage reference indicated in the table below:

	Volts ~	24	48	110	220	230	240
LC1 D09...D115	50 Hz	B5	E5	F5	M5	P5	U5
	60 Hz	B6	E6	F6	M6	–	U6
LC1 F185	50/60 Hz	B7	E7	F7	M7	P7	U7
	50 Hz (LX1 coil)	B5	E5	F5	M5	P5	U5
	60 Hz (LX1 coil)	–	E6	F6	M6	–	U6
LC1 F265, LC1 F330	40...400 Hz (LX9 coil)	–	E7	F7	M7	P7	U7
	40...400 Hz (LX1 coil)	B7	E7	F7	M7	P7	U7
LC1 F400...F630	40...400 Hz (LX1 coil)	–	E7	F7	M7	P7	U7

For other voltages available between 24 V and 660 V, or a DC control circuit, please consult your Regional Sales Office.

DF534573



DF534574



PF537422



NS160●MA150  
+  
LC1 D115●●  
+  
ATV 61HD75N4

### Motor starters for UL Type 1/IP 20 drives

Motor		Drive	Circuit-breaker		Line contactor	
Power (1)	Reference	Reference (2)	Rating	I <sub>rm</sub>	Reference (3) (4)	
kW	HP		A	A		
<b>Three-phase supply voltage: 440...480 V 50/60 Hz. Type 1 coordination</b>						
0.75	1	ATV 61H075N4	GV2 LE08	4	–	LC1 K06●●
1.5	2	ATV 61HU15N4	GV2 LE10	6.3	–	LC1 K06●●
2.2	3	ATV 61HU22N4	GV2 LE14	10	–	LC1 K06●●
3	–	ATV 61HU30N4	GV2 LE14	10	–	LC1 K06●●
4	5	ATV 61HU40N4	GV2 LE16	14	–	LC1 D09●●
5.5	7.5	ATV 61HU55N4	GV2 LE20	18	–	LC1 D09●●
7.5	10	ATV 61HU75N4	GV2 LE22	25	–	LC1 D18●●
11	15	ATV 61HD11N4	GV2 LE32	32	–	LC1 D25●●
15	20	ATV 61HD15N4	NS80HMA50	50	300	LC1 D40●●
18.5	25	ATV 61HD18N4	NS80HMA50	50	300	LC1 D40●●
22	30	ATV 61HD22N4	NS80HMA50	50	300	LC1 D40●●
30	40	ATV 61HD30N4	NS80HMA80	80	300	LC1 D50●●
37	50	ATV 61HD37N4	NS80HMA80	80	300	LC1 D65●●
45	60	ATV 61HD45N4	NS100HMA100	100	600	LC1 D80●●
55	75	ATV 61HD55N4	NS100HMA100	100	600	LC1 D80●●
75	100	ATV 61HD75N4	NS160●MA150	150	1350	LC1 D115●●
90	125	ATV 61HD90N4	NS160●MA150	150	1350	LC1 D115●●
110	150	ATV 61HC11N4	NS250●MA220	220	1980	LC1 D115●●
132	200	ATV 61HC13N4	NS250●MA220	220	1980	LC1 F265●●
160	250	ATV 61HC16N4	NS400●MA320	320	1920	LC1 F330●●
200	300	ATV 61HC22N4	NS630●MAE500	500	3000	LC1 F330●●
220	350	ATV 61HC22N4	NS630●MAE500	500	3000	LC1 F400●●
250	400	ATV 61HC25N4	NS630●MAE500	500	3000	LC1 F500●●
280	450	ATV 61HC31N4	NS630●MAE500	500	3000	LC1 F500●●
315	500	ATV 61HC31N4	NS800 Micrologic 2 or 5 (LR OFF)	800	1600	LC1 F630●●
355	–	ATV 61HC40N4	NS800 Micrologic 2 or 5 (LR OFF)	800	1600	LC1 F630●●
400	600	ATV 61HC40N4	NS800 Micrologic 2 or 5 (LR OFF)	800	1600	LC1 F630●●
500	700	ATV 61HC50N4	NS800 Micrologic 2 or 5 (LR OFF)	800	1600	LC1 F630●●
560	800	ATV 61HC63N4	NS1000 Micrologic 2 or 5 (LR OFF)	1000	2000	LC1 F630●●
630	900	ATV 61HC63N4	NS1000 Micrologic 2 or 5 (LR OFF)	1000	2000	LC1 F630●●

(1) Standard power ratings for 4-pole motors 400 V 50/60 Hz.

The values expressed in HP comply with the NEC (National Electrical Code).

(2) NS80HMA●●, NS●●●●: Products sold under the Merlin Gerin brand.

For references to be completed, replace the dot with the letter corresponding to the circuit-breaker breaking performance (N, H, L).

Breaking capacity of circuit-breakers according to standard IEC 60947-2:

Circuit-breaker	I <sub>cu</sub> (kA) for 440 V		
	N	H	L
GV2 LE08	100	–	–
GV2 LE10	50	–	–
GV2 LE14	15	–	–
GV2 LE16, GV2 LE20	8	–	–
GV2 LE22, GV2 LE32	6	–	–
NS80HMA	65	–	–
NS100●MA	–	25	130
NS160●MA, NS250●MA	–	35	130
NS400●MA, NS630●MAE	–	42	130
NS800 Micrologic 2 or 5, NS1000 Micrologic 2 or 5	–	50	–

(3) Composition of contactors:

LC1 K06: 3 poles + 1 "N/O" auxiliary contact + 1 "N/C" auxiliary contact.

LC1 D●●: 3 poles + 1 "N/O" auxiliary contact + 1 "N/C" auxiliary contact.

LC1 F●●●: 3 poles. To add auxiliary contacts or other accessories, please refer to the "Motor starter solutions. Control and protection components" catalogue.

(4) Replace ●● with the control circuit voltage reference indicated in the table below:

	Volts ~	24	48	110	220	230	240
LC1 K06	50/60 Hz	B7	E7	F7	M7	P7	U7
LC1 D09...D115	50 Hz	B5	E5	F5	M5	P5	U5
	60 Hz	B6	E6	F6	M6	–	U6
	50/60 Hz	B7	E7	F7	M7	P7	U7
LC1 F265, LC1 F330	40...400 Hz (LX1 coil)	B7	E7	F7	M7	P7	U7
LC1 F400...F630	40...400 Hz (LX1 coil)	–	E7	F7	M7	P7	U7

For other voltages available between 24 V and 660 V, or a DC control circuit, please consult your Regional Sales Office.

DF534573



DF534574



PF107482



NS100●MA100  
+  
LC1 D115●●  
+  
ATV 61WD55N4

**Motor starters for UL Type 12/IP 54 drives**

Motor		Drive	Circuit-breaker	Line contactor	
Power (1)	Reference	Reference (2)	Rating	I <sub>rm</sub>	Reference (3) (4)
kW	HP		A	A	
<b>Three-phase supply voltage: 440...480 V 50/60 Hz. Type 2 coordination</b>					
0.75	1	ATV 61W075N4 ATV 61W075N4C	GV2 L07	2.5	– LC1 D09●●
1.5	2	ATV 61WU15N4 ATV 61WU15N4C	GV2 L08	4	– LC1 D09●●
2.2	3	ATV 61WU22N4 ATV 61WU22N4C	GV2 L10	6.3	– LC1 D09●●
3	–	ATV 61WU30N4 ATV 61WU30N4C	GV2 L10	6.3	– LC1 D09●●
4	5	ATV 61WU40N4 ATV 61WU40N4C	GV2 L14	10	– LC1 D09●●
5.5	7.5	ATV 61WU55N4 ATV 61WU55N4C	GV2 L14	10	– LC1 D18●●
7.5	10	ATV 61WU75N4 ATV 61WU75N4C	GV3 L32	32	– LC1 D40●●
11	15	ATV 61WD11N4 ATV 61WD11N4C	GV3 L40	40	– LC1 D40●●
15	20	ATV 61WD15N4 ATV 61WD15N4C	GV3 L50	50	– LC1 D50●●
18.5	25	ATV 61WD18N4 ATV 61WD18N4C	GV3 L50	50	300 LC1 D50●●
22	30	ATV 61WD22N4 ATV 61WD22N4C	GV3 L65	65	300 LC1 D65●●
30	40	ATV 61WD30N4 ATV 61WD30N4C	NS80HMA50	50	300 LC1 D50●●
37	50	ATV 61WD37N4 ATV 61WD37N4C	NS80HMA80	80	480 LC1 D80●●
45	60	ATV 61WD45N4 ATV 61WD45N4C	NS80HMA80	80	480 LC1 D80●●
55	75	ATV 61WD55N4 ATV 61WD55N4C	NS100●MA100	100	600 LC1 D115●●
75	100	ATV 61WD75N4 ATV 61WD75N4C	NS160●MA150	150	1350 LC1 D115●●
90	125	ATV 61WD90N4 ATV 61WD90N4C	NS250●MA220	220	1980 LC1 F185●●

- (1) Standard power ratings for 4-pole motors 400 V 50/60 Hz.  
The values expressed in HP comply with the NEC (National Electrical Code).  
(2) NS80HMA●●, NS●●●●: Products sold under the Merlin Gerin brand.  
For references to be completed, replace the dot with the letter corresponding to the circuit-breaker breaking performance (N, H, L).  
Breaking capacity of circuit-breakers according to standard IEC 60947-2:

Circuit-breaker	I <sub>cu</sub> (kA) for 440 V			
	N	H	L	
GV2 L07...GV2 L10	100	–	–	–
GV2 L14...L32	20	–	–	–
NS80HMA	65	–	–	–
NS100●MA	–	25	65	130
NS160●MA, NS250●MA	–	35	65	130

- (3) Composition of contactors:  
LC1 D●●: 3 poles + 1 "N/O" auxiliary contact and 1 "N/C" auxiliary contact.  
LC1 F185: 3 poles. To add auxiliary contacts or other accessories, please refer to the "Motor starter solutions. Control and protection components" catalogue.  
(4) Replace ●● with the control circuit voltage reference indicated in the table below:

LC1 D09...D115	Volts ~	24	48	110	220	230	240
	50 Hz	B5	E5	F5	M5	P5	U5
60 Hz	B6	E6	F6	M6	–	U6	
50/60 Hz	B7	E7	F7	M7	P7	U7	
LC1 F185	50 Hz (LX1 coil)	B5	E5	F5	M5	P5	U5
	60 Hz (LX1 coil)	–	E6	F6	M6	–	U6
	40...400 Hz (LX9 coil)	–	E7	F7	M7	P7	U7

For other voltages available between 24 V and 660 V, or a DC control circuit, please consult your Regional Sales Office.

DF534673



DF534632



PF107492



NS100●MA100  
+  
LC1 D80●●  
+  
ATV 61WD55N4

Motor starters for UL Type 12/IP 54 drives						
Motor		Drive	Circuit-breaker		Line contactor	
Power (1)		Reference	Reference (2)		Rating	Irm
kW	HP				A	A
<b>Three-phase supply voltage: 440...480 V 50/60 Hz. Type 1 coordination</b>						
0.75	1	ATV 61W075N4 ATV 61W075N4C	GV2 LE07		2.5	–
1.5	2	ATV 61WU15N4 ATV 61WU15N4C	GV2 LE08		4	–
2.2	3	ATV 61WU22N4 ATV 61WU22N4C	GV2 LE10		6.3	–
3	–	ATV 61WU30N4 ATV 61WU30N4C	GV2 LE10		6.3	–
4	5	ATV 61WU40N4 ATV 61WU40N4C	GV2 LE14		10	–
5.5	7.5	ATV 61WU55N4 ATV 61WU55N4C	GV2 LE14		10	–
7.5	10	ATV 61WU75N4 ATV 61WU75N4C	GV2 LE20		18	–
11	15	ATV 61WD11N4 ATV 61WD11N4C	GV2 LE22		25	–
15	20	ATV 61WD15N4 ATV 61WD15N4C	GV2 LE32		32	–
18.5	25	ATV 61WD18N4 ATV 61WD18N4C	NS80HMA50		50	300
22	30	ATV 61WD22N4 ATV 61WD22N4C	NS80HMA50		50	300
30	40	ATV 61WD30N4 ATV 61WD30N4C	NS80HMA50		50	300
37	50	ATV 61WD37N4 ATV 61WD37N4C	NS80HMA80		80	480
45	60	ATV 61WD45N4 ATV 61WD45N4C	NS80HMA80		80	480
55	75	ATV 61WD55N4 ATV 61WD55N4C	NS100●MA100		100	600
75	100	ATV 61WD75N4 ATV 61WD75N4C	NS160●MA150		150	1350
90	125	ATV 61WD90N4 ATV 61WD90N4C	NS250●MA220		220	1980

(1) Standard power ratings for 4-pole motors 400 V 50/60 Hz.

The values expressed in HP comply with the NEC (National Electrical Code).

(2) NS80HMA●●, NS●●●●: Products sold under the Merlin Gerin brand.

For references to be completed, replace the dot with the letter corresponding to the circuit-breaker breaking performance (N, H, L).  
Breaking capacity of circuit-breakers according to standard IEC 60947-2:

Circuit-breaker	Icu (kA) for 440 V			
	N	H	L	
GV2 LE07...LE10	100	–	–	
GV2 LE14...LE32	20	–	–	
NS80HMA	65	–	–	
NS100●MA	–	25	65	130
NS160●MA, NS250●MA	–	35	65	130

(3) Composition of contactors:

LC1 K06: 3 poles + 1 "N/O" auxiliary contact and 1 "N/C" auxiliary contact.

LC1 D●●: 3 poles + 1 "N/O" auxiliary contact and 1 "N/C" auxiliary contact.

(4) Replace ●● with the control circuit voltage reference indicated in the table below:

	Volts ~	24	48	110	220	230	240
LC1 K06	50/60 Hz	B7	E7	F7	M7	P7	U7
LC1 D09...D115	50 Hz	B5	E5	F5	M5	P5	U5
	60 Hz	B6	E6	F6	M6	–	U6
	50/60 Hz	B7	E7	F7	M7	P7	U7

For other voltages available between 24 V and 660 V, or a DC control circuit, please consult your Regional Sales Office.



DF535986-16-M



103282-14-M



PF107582



GV2 L16  
+  
LC1 D25●●  
+  
ATV 61HU75Y

**Motor starters for UL Type 1/IP 20 drives**

Motor Power (1) kW	Drive Reference	Circuit-breaker		Line contactor		
		Reference (2)	Rating A	I <sub>rm</sub> A	Reference (3) (4)	
<b>Three-phase supply voltage 690 V 50 Hz. Type 2 coordination</b>						
3	ATV 61HU30Y	GV2 L10	6,3	–	LC1 D25●●	
4	ATV 61HU40Y	GV2 L14	10	–	LC1 D25●●	
5.5	ATV 61HU55Y	GV2 L14	10	–	LC1 D25●●	
7.5	ATV 61HU75Y	GV2 L16	14	–	LC1 D25●●	
11	ATV 61HD11Y	GV2 L20	18	–	LC1 D40●●	
15	ATV 61HD15Y	GV2 L22	25	–	LC1 D40●●	
18.5	ATV 61HD18Y	GV3 L25	25	–	LC1 D40●●	
22	ATV 61HD22Y	GV3 L32	32	–	LC1 D65●●	
30	ATV 61HD30Y	GV3 L40	40	–	LC1 D80●●	
37	ATV 61HD37Y	GV3 L50	50	–	LC1 D80●●	
45	ATV 61HD45Y	GV3 L65	65	–	LC1 D80●●	
55	ATV 61HD55Y	NS100LMA100	100	1100	LC1 D80●●	
75	ATV 61HD75Y	NS100LMA100	100	1100	LC1 D95●●	
90	ATV 61HD90Y	NS400LMA320	320	2880	LC1 F265●●	
110	ATV 61HC11Y	NS400LMA320	320	2880	LC1 F265●●	
132	ATV 61HC13Y	NS400LMA320	320	2880	LC1 F265●●	
160	ATV 61HC16Y	NS400LMA320	320	2880	LC1 F265●●	
200	ATV 61HC20Y	NS400LMA320	320	2880	LC1 F330●●	

(1) Standard power ratings for 690 V 50 Hz 4-pole motors.

(2) NS●●●LMA: Products sold under the Merlin Gerin brand.

Breaking capacity of circuit-breakers according to standard IEC 60947-2:

Circuit-breaker	I <sub>cu</sub> (kA) for 690 V
GV2 L10...L22, GV3 L25, L32	4
GV3 L40...L65	5
NS●●●LMA	75

(3) Composition of contactors:

LC1 D●●: 3 poles + 1 "N/O" auxiliary contact + 1 "N/C" auxiliary contact.

LC1 F●●●: 3 poles. To add auxiliary contacts or other accessories, please refer to the "Motor starter solutions. Control and protection components" catalogue.

(4) Replace ●● with the control circuit voltage reference indicated in the table below:

	Volts ~	24	48	110	220	230	240
LC1 D	50 Hz	B5	E5	F5	M5	P5	U5
	60 Hz	B6	E6	F6	M6	–	U6
	50/60 Hz	B7	E7	F7	M7	P7	U7
LC1 F	40...400 Hz (LX1 coil)	B7	E7	F7	M7	P7	U7

For other voltages available between 24 V and 660 V, or a DC control circuit, please consult your Regional Sales Office.

PF048286



PF105715



PF107585



NS630LMA500  
+  
LC1 F400  
+  
ATV 61HC25Y

**Motor starters for UL Type 1/IP 20 drives**

Motor Power (1) kW	Drive Reference	Circuit-breaker			Line contactor Reference (3) (4)
		Reference (2)	Rating A	I <sub>rm</sub> A	
<b>Three-phase supply voltage 690 V 50 Hz. Type 1 coordination</b>					
250	ATV 61HC25Y	NS630LMA500	500	–	LC1 F400●●
315	ATV 61HC31Y	NS630LMA500	500	–	LC1 F500●●
400	ATV 61HC40Y	NS630LMA500	500	–	LC1 F630●●
500	ATV 61HC50Y	NS630L Micrologic 5	630	–	LC1 BL33●●
630	ATV 61HC63Y	NS630L Micrologic 5	630	–	LC1 BL33●●

(1) Standard power ratings for 690 V 50 Hz 4-pole motors.

(2) NS630L: Products sold under the Merlin Gerin brand.

Breaking capacity of circuit-breakers according to standard IEC 60947-2:

Circuit-breaker	I <sub>cu</sub> (kA) for 690 V
NS630L	75

(3) Composition of contactors:

LC1 F●●●: 3 poles. To add auxiliary contacts or other accessories, please refer to the "Motor starter solutions. Control and protection components" catalogue.

LC1 BL●●: 3 poles. To add auxiliary contacts or other accessories, please refer to the "Motor starter solutions. Control and protection components" catalogue.

(4) Replace ●● with the control circuit voltage reference indicated in the table below:

	Volts ~	24	48	110	220	230	240
LC1 F	40...400 Hz (LX1 coil)	–	E7	F7	M7	P7	U7
LC1 BL	50...400 Hz (WB1 coil)	–	–	F	M	P	U

For other voltages available between 24 V and 660 V, or a DC control circuit, please consult your Regional Sales Office.

#### Installation recommendations

Depending on the conditions in which the drive is to be used, its installation will require certain precautions and the use of appropriate accessories.

Install the unit vertically:

- Avoid placing it close to heating elements
- Leave sufficient free space to ensure that the air required for cooling purposes can circulate from the bottom to the top of the unit.

**ATV 61H●●●M3, ATV 61HD11M3X...HD45M3X, ATV 61H075N4...HD75N4, ATV 61HU30Y...HD90Y**

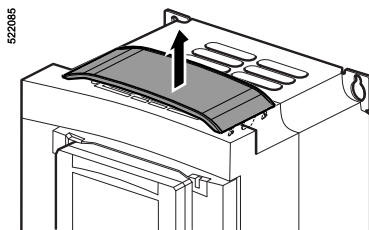
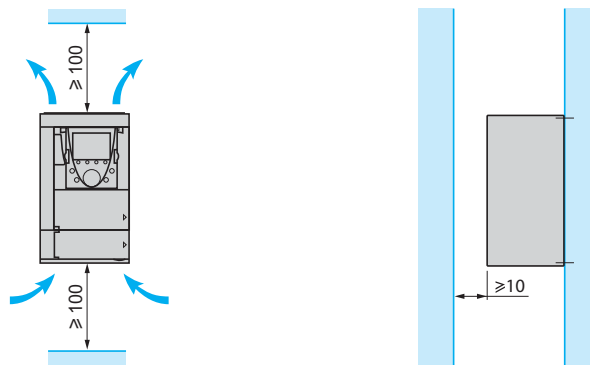

522085  
Removing the protective blanking cover from:  
ATV 61H●●●M3, ATV 61HD11M3X, HD15M3X,  
ATV 61H075N4...HD18N4

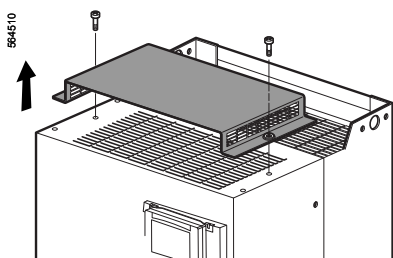

564510  
Removing the protective blanking cover from:  
ATV 61HD18M3X...HD45M3X,  
ATV 61HD22N4...HD75N4,  
ATV 61HU30Y...HD90Y

#### Mounting types

##### ■ Type A mounting

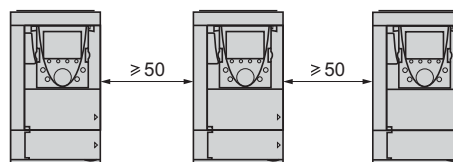

##### ■ Type B mounting

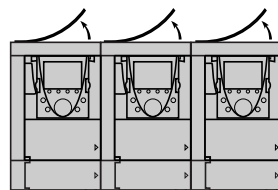

##### ■ Type C mounting

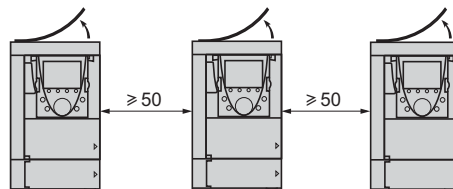

By removing the protective blanking cover from the top of the drive, the degree of protection for the drive becomes IP 20. The protective cover may vary according to the drive model (see opposite).

#### Derating curves for ATV 61H●●●M3, ATV 61HD11M3X...HD45M3X and ATV 61HD37N4...HD75N4

The derating curves for the drive nominal current ( $I_n$ ) depend on the temperature, the switching frequency and the mounting type.

For intermediate temperatures (55°C for example), interpolate between 2 curves.

#### ATV 61H●●●M3, ATV 61HD11M3X, HD15M3X and ATV 61H075N4...HD18N4

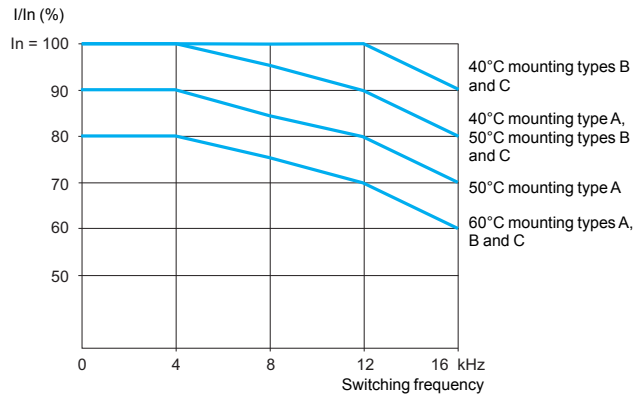

#### ATV 61HD22N4, HD30N4 (1)

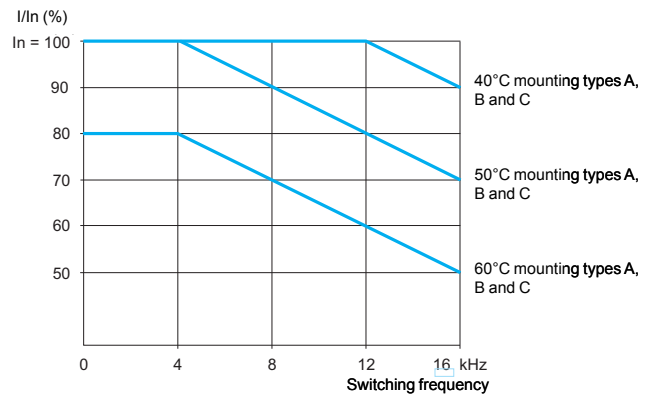

#### ATV 61HD18M3X...HD45M3X and ATV 61HD37N4...HD75N4 (1)

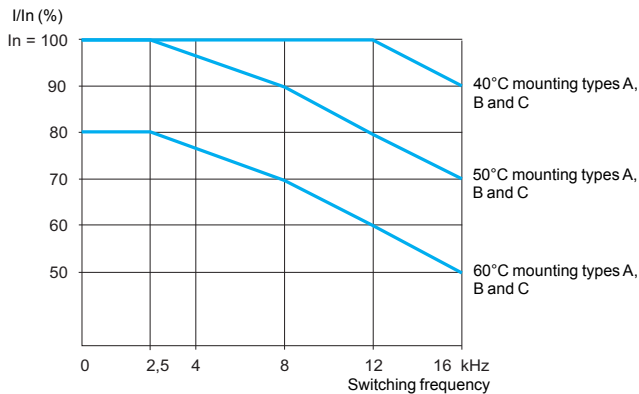

(1) Above 50 °C, ATV 61HD18M3X...HD45M3X and ATV 61HD22N4...HD75N4 drives should be equipped with a control card fan kit. See page 27.

#### Derating curves for ATV 61HU30Y...HD90Y

ATV 61HU30Y...HD18Y (1)

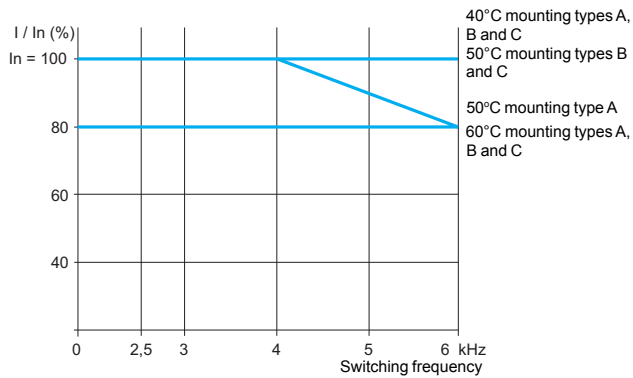

ATV 61HD22Y...HD30Y (1)

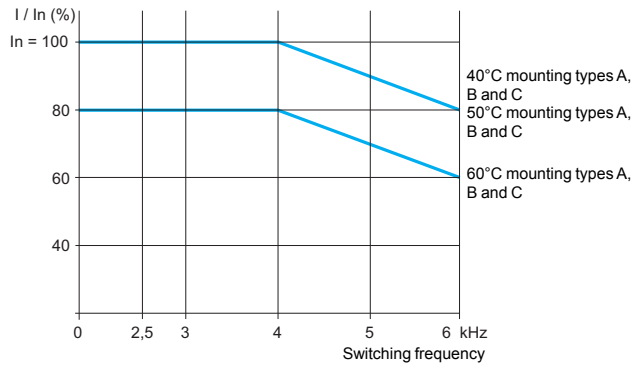

ATV 61HD37Y...HD75Y (1)

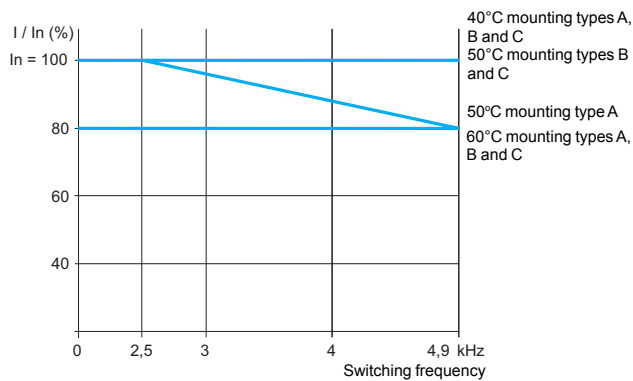

ATV 61HD90Y (1)

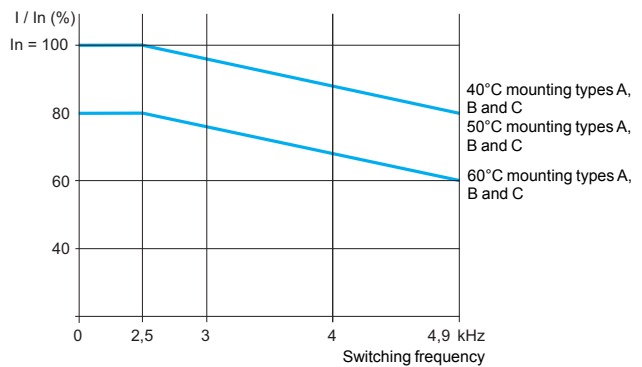

(1) Above 50°C, ATV 61HU30Y...HD90Y drives should be equipped with a control card fan kit. See page 27.

**Mounting recommendations (continued)**

ATV 61HD55M3X...HD90M3X, ATV 61HD90N4...HC63N4, ATV 61HC11Y...HC80Y

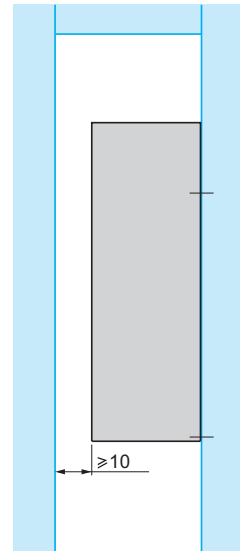
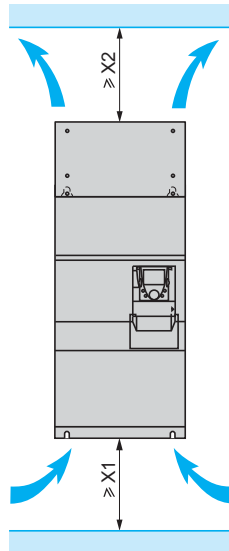

ATV 61H	X1	X2
D55M3X...D90M3X, D90N4, C11N4	100	100
C13N4...C22N4, C11Y...C20Y	150	150
C25N4, C31N4, C25Y...C40Y	150	200
C40N4, C50N4	250	300
C63N4, C50Y...C80Y	250	400

These drives can be mounted side by side, observing the following mounting recommendations:

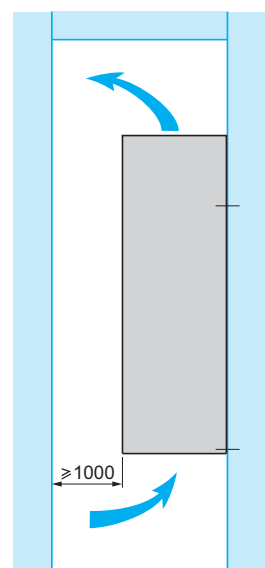
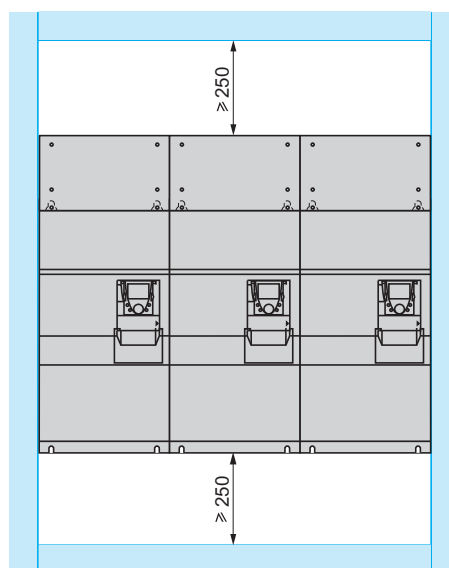

#### Derating curves for ATV 61HD55M3X...HD90M3X, ATV 61HD90N4...HC13N4

The derating curves for the drive nominal current ( $I_n$ ) depend on the temperature, the switching frequency and the mounting type.

For intermediate temperatures (e.g. 55°C), interpolate between 2 curves.

#### ATV 61HD55M3X...HD90M3X

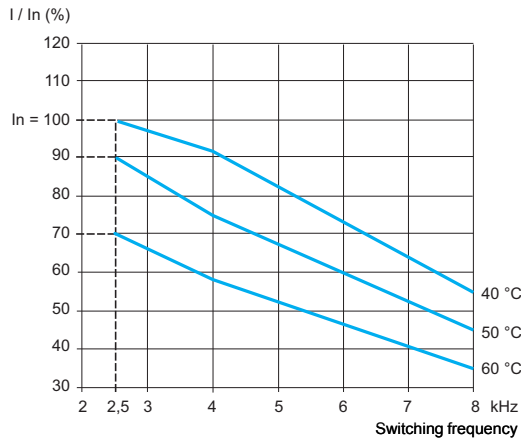

#### ATV 61HD90N4

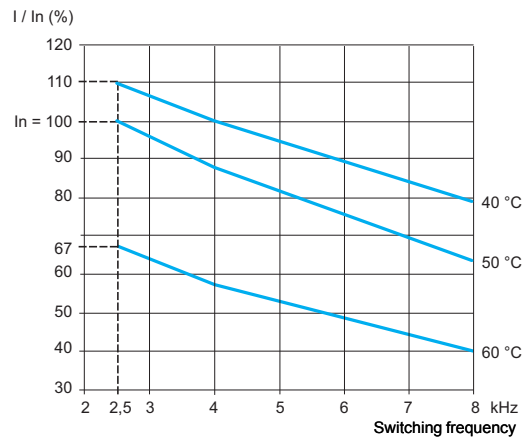

#### ATV 61HC11N4

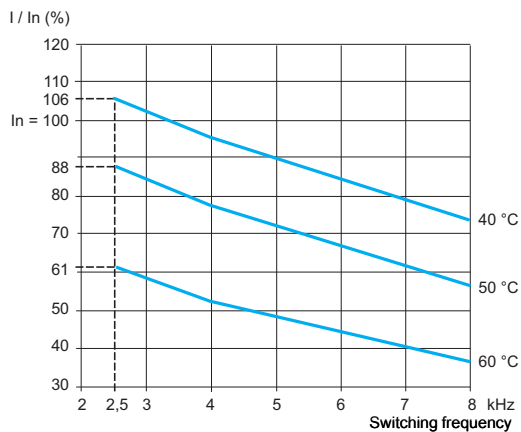

#### ATV 61HC13N4

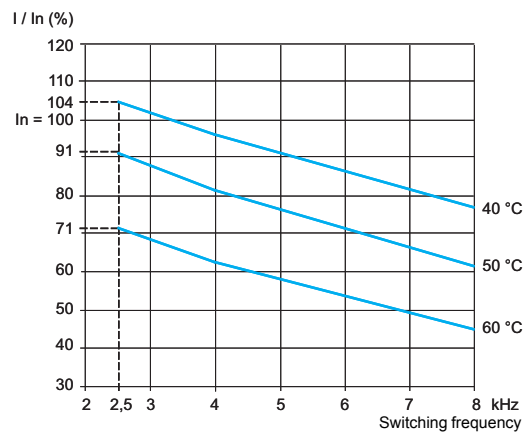

#### Derating curves for ATV 61HC16N4...HC31N4

**ATV 61HC16N4**

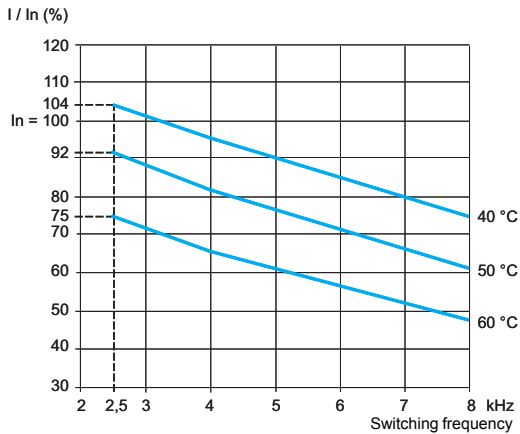

**ATV 61HC22N4 combined with a 200 kW motor**

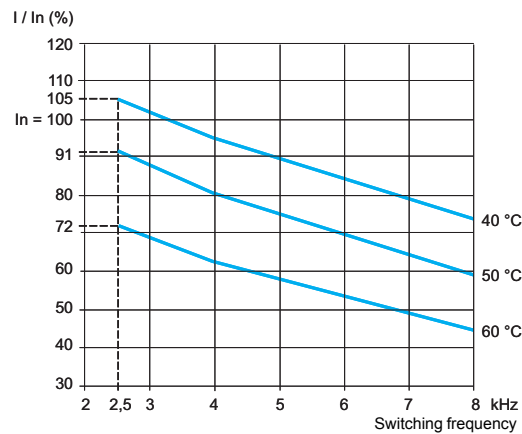

**ATV 61HC22N4 combined with a 220 kW motor**

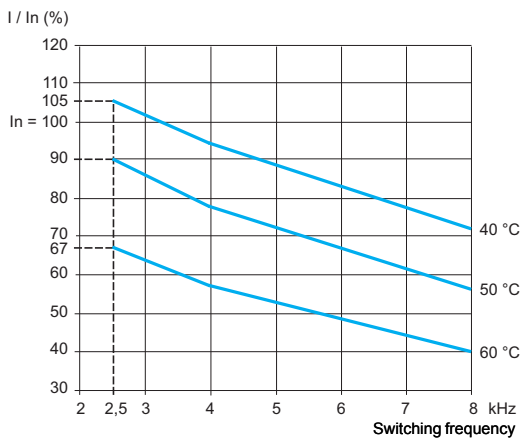

**ATV 61HC25N4**

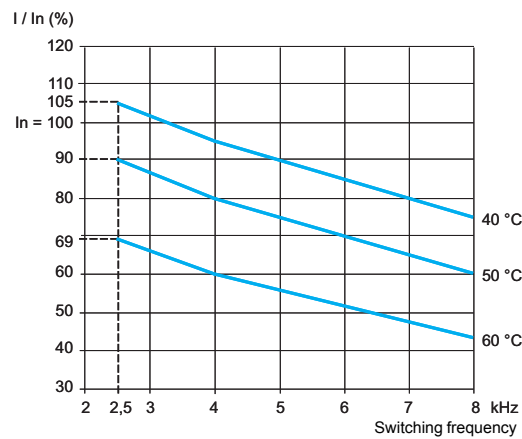

**ATV 61HC31N4 combined with a 280 kW motor**

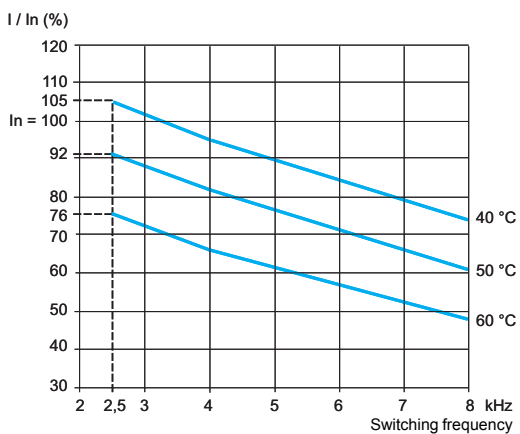

**ATV 61HC31N4 combined with a 315 kW motor**

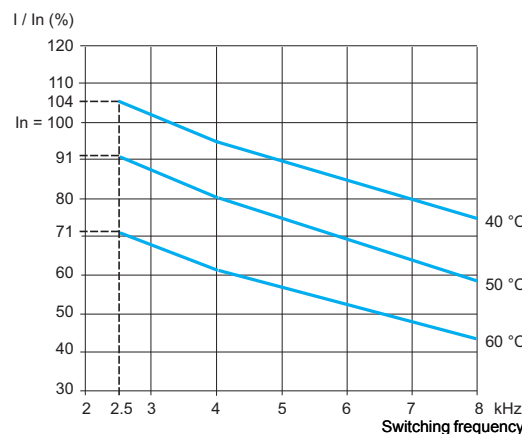



#### Derating curves for ATV 61HC40N4...HC63N4

ATV 61HC40N4 combined with a 355 kW motor

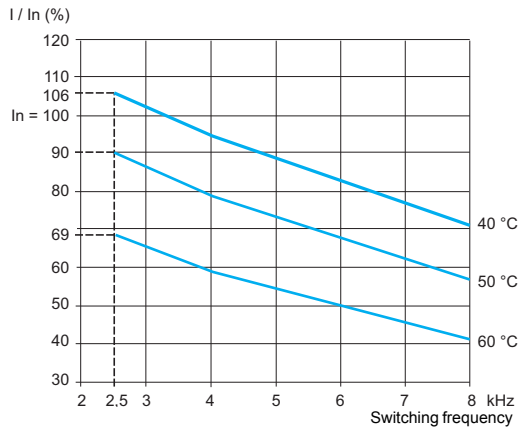

ATV 61HC40N4 combined with a 400 kW motor

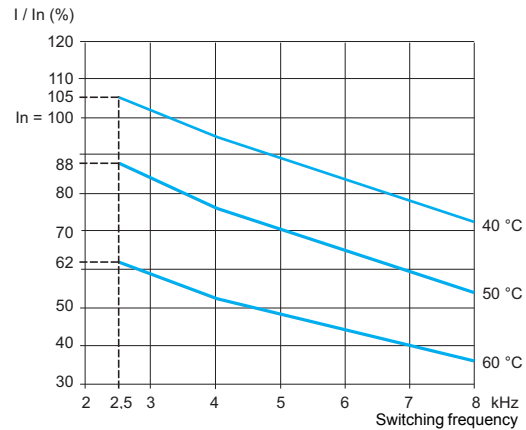

ATV 61HC50N4

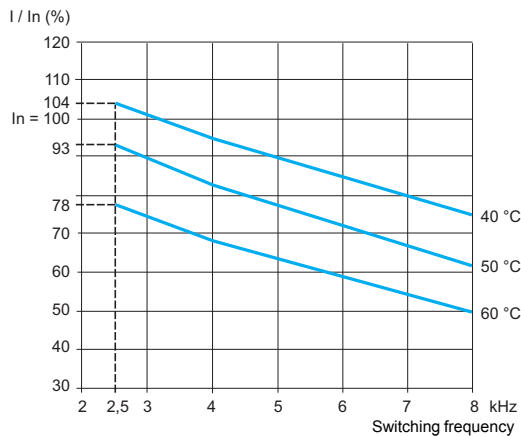

ATV 61HC63N4 combined with a 560 kW motor

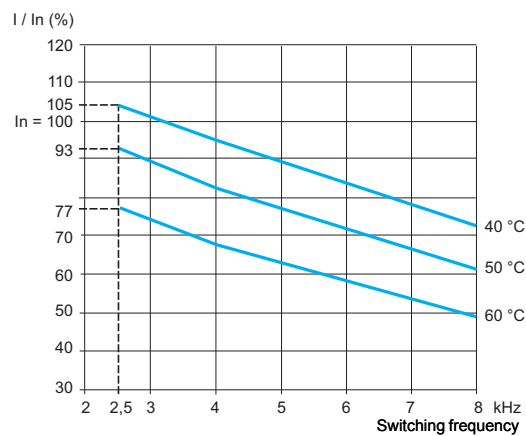

ATV 61HC63N4 combined with a 630 kW motor

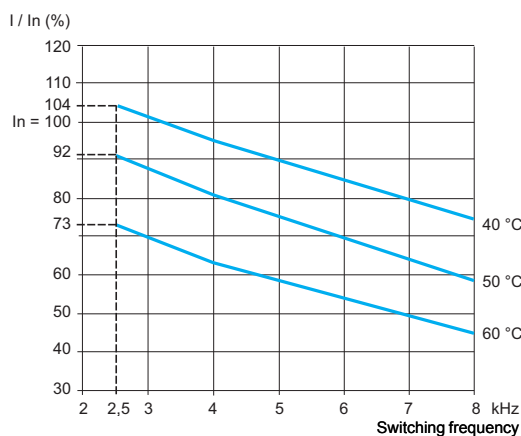

#### Derating curves for ATV 61HC11Y...HC31Y

##### ATV 61HC11Y

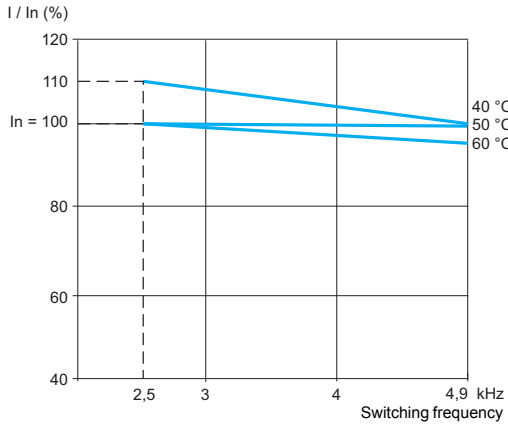

##### ATV 61HC13Y

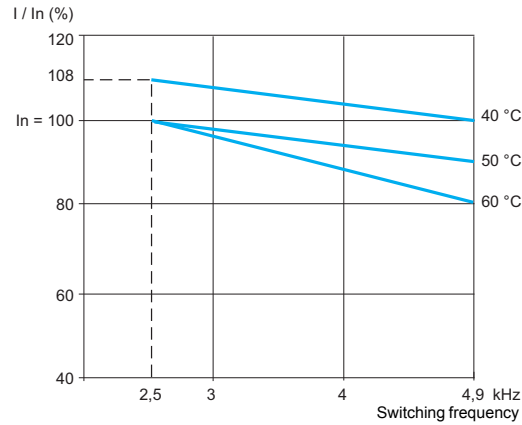

##### ATV 61HC16Y

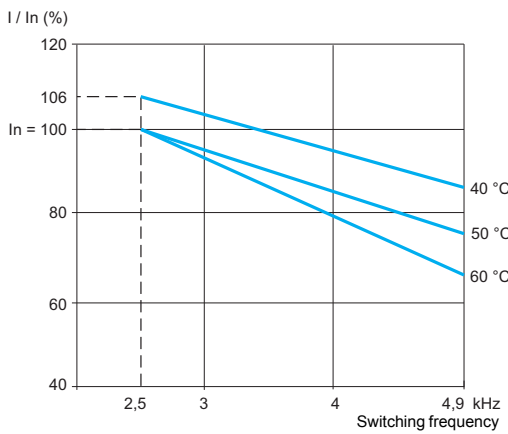

##### ATV 61HC20Y

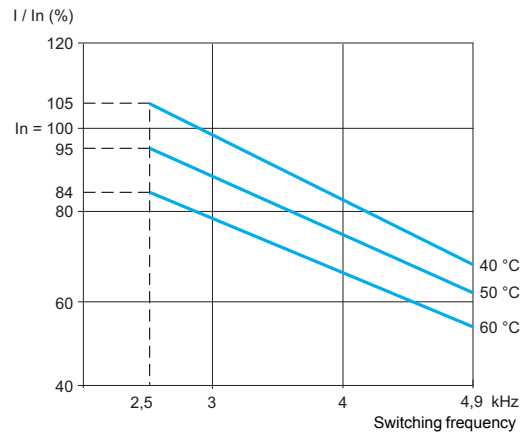

##### ATV 61HC25Y

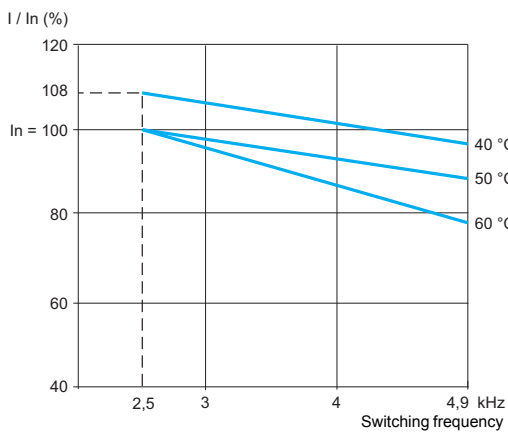

##### ATV 61HC31Y

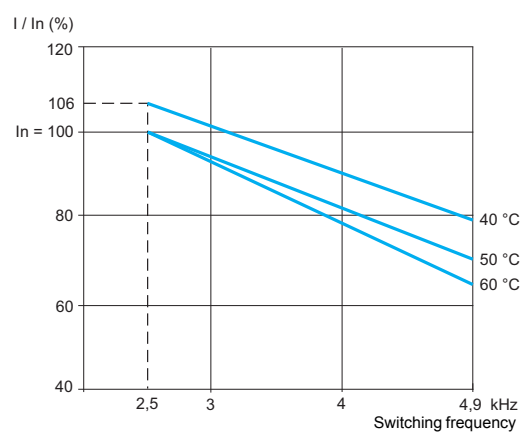

#### Derating curves for ATV 61HC40Y...HC80Y

##### ATV 61HC40Y

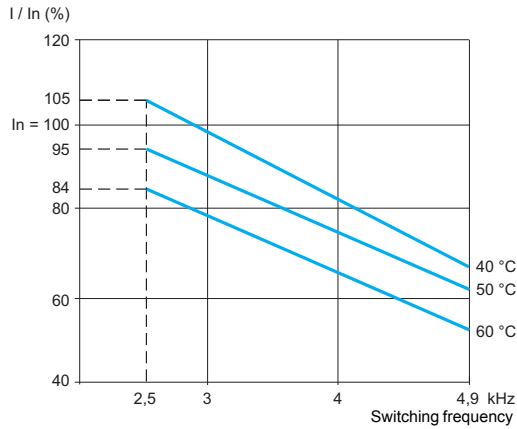

##### ATV 61HC50Y

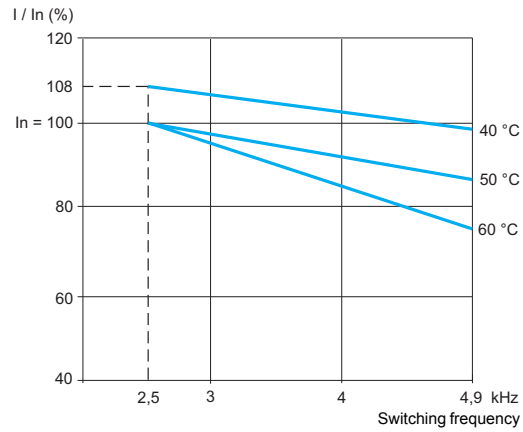

##### ATV 61HC63Y

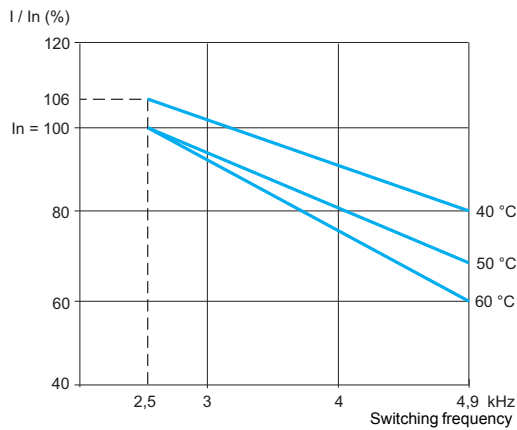

##### ATV 61HC80Y

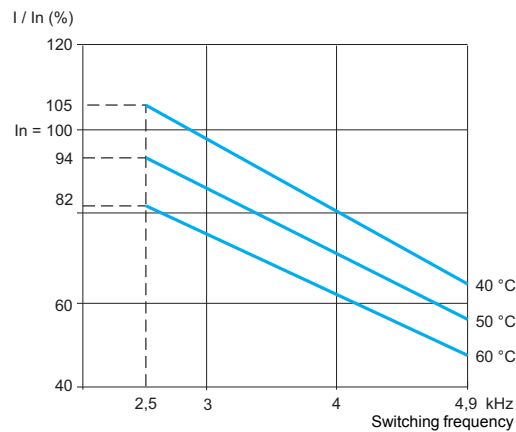

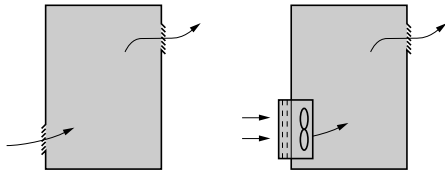

### Specific recommendations for mounting in an enclosure

Follow the mounting recommendations described on pages 240 to 248.

To ensure proper air circulation in the drive:

- Fit ventilation grilles.
- Ensure that there is sufficient ventilation. If there is not, install a forced ventilation unit with a filter. The openings and/or fans must provide a flow rate at least equal to that of the drive fans (see page 251).
- Use special filters with IP 54 protection.
- Remove the blanking cover from the top of the drive (see page 240).

### Power dissipated inside the enclosure

For drives	Dissipated power (1)	
	Mounted in the enclosure (power section inside the enclosure)	Dust and damp proof flush-mounted (power section outside the enclosure)
	W	W
<b>Three-phase supply voltage: 200...240 V 50/60 Hz</b>		
ATV 61H075M3	66	27
ATV 61HU15M3	101	30
ATV 61HU22M3	122	38
ATV 61HU30M3	154	38
ATV 61HU40M3	191	41
ATV 61HU55M3	293	59
ATV 61HU75M3	363	67
ATV 61HD11M3X	566	80
ATV 61HD15M3X	620	84
ATV 61HD18M3X	657	114
ATV 61HD22M3X	766	124
ATV 61HD30M3X	980	144
ATV 61HD37M3X	1154	161
ATV 61HD45M3X	1366	180
ATV 61HD55M3X	1715	154
ATV 61HD75M3X	1715	154
ATV 61HD90M3X	2204	154

### Three-phase supply voltage: 380...480 V 50/60 Hz

ATV 61H075N4	44	26
ATV 61HU15N4	64	28
ATV 61HU22N4	87	30
ATV 61HU30N4	114	35
ATV 61HU40N4	144	40
ATV 61HU55N4	178	50
ATV 61HU75N4	217	55
ATV 61HD11N4	320	65
ATV 61HD15N4	392	85
ATV 61HD18N4	486	86
ATV 61HD22N4	574	110
ATV 61HD30N4	799	135
ATV 61HD37N4	861	137
ATV 61HD45N4	1060	165
ATV 61HD55N4	1210	178
ATV 61HD75N4	1720	225
ATV 61HD90N4	2065	237
ATV 61HC11N4	2514	237
ATV 61HC13N4	3179	261
ATV 61HC16N4	4036	296
ATV 61HC22N4	5482	350
ATV 61HC25N4	6379	493
ATV 61HC31N4	7867	658
ATV 61HC40N4	9598	772
ATV 61HC50N4	12055	935
ATV 61HC63N4	15007	1116

(1) This value is given for operation at nominal load and for a switching frequency of 2.5 or 4 kHz depending on the rating.

Add 7 W to this value for each additional option card.

#### Power dissipated inside the enclosure (continued)

For drives	Dissipated power (1)	
	Mounted in the enclosure (power section inside the enclosure)	Dust and damp proof flush- mounted (power section outside the enclosure)
	W	W
<b>Three-phase supply voltage: 500...690 V 50/60 Hz</b>		
ATV 61HU30Y	111	71
ATV 61HU40Y	119	71
ATV 61HU55Y	136	73
ATV 61HU75Y	158	75
ATV 61HD11Y	182	77
ATV 61HD15Y	227	81
ATV 61HD18Y	300	87
ATV 61HD22Y	386	94
ATV 61HD30Y	463	100
ATV 61HD37Y	716	120
ATV 61HD45Y	716	120
ATV 61HD55Y	911	133
ATV 61HD75Y	1087	144
ATV 61HD90Y	1545	158
ATV 61HC11Y	2325	174
ATV 61HC13Y	2751	189
ATV 61HC16Y	3287	213
ATV 61HC20Y	4031	244
ATV 61HC25Y	5159	326
ATV 61HC31Y	6308	377
ATV 61HC40Y	7551	439
ATV 61HC50Y	9659	580
ATV 61HC63Y	11954	692
ATV 61HC80Y	14983	857

(1) This value is given for operation at nominal load and for a switching frequency of 2.5 or 4 kHz depending on the rating.  
Add 7 W to this value for each additional option card.

#### Fan flow rate depending on the drive rating

For drive	Flow rate m <sup>3</sup> /hour
ATV 61H075M3, HU15M3	17
ATV 61HU22M3...HU40M3	56
ATV 61HU55M3	112
ATV 61HU75M3	163
ATV 61HD11M3X, HD15M3X	252
ATV 61HD18M3X, HD22M3X	203
ATV 61HD30M3X...HD45M3X	406
ATV 61HD55M3X, HD75M3X	402
ATV 61HD90M3X	774
ATV 61H075N4...HU22N4	17
ATV 61HU30N4, HU40N4	56
ATV 61HU55N4, HU75N4	112
ATV 61HD11N4	163
ATV 61HD15N4, HD18N4	252
ATV 61HD22N4...HD37N4	203
ATV 61HD45N4...HD75N4	406
ATV 61HD90N4, HC11N4	402
ATV 61HC13N4	774
ATV 61HC16N4	745
ATV 61HC22N4	860
ATV 61HC25N4, HC31N4	1260
ATV 61HC40N4, HC50N4	2100
ATV 61HC63N4	2400
ATV 61HU30Y...HD30Y	330
ATV 61HD37Y...HD90Y	406
ATV 61HC11Y...HC20Y	600
ATV 61HC25Y...HC40Y	1200
ATV 61HC50Y...HC80Y	2400

#### Dust and damp proof metal enclosure (IP 54 degree of protection)

The drive must be mounted in a dust and damp proof enclosure in certain environmental conditions, such as dust, corrosive gases, high humidity with risk of condensation and dripping water, splashing liquid, etc.  
This enables the drive to be used in an enclosure where the maximum internal temperature reaches 50°C.

#### Calculating the dimensions of the enclosure

##### Maximum thermal resistance R<sub>th</sub> (°C/W)

$$R_{th} = \frac{\theta - \theta_e}{P}$$

$\theta$  = maximum temperature inside enclosure in °C  
 $\theta_e$  = maximum external temperature in °C  
 $P$  = total power dissipated in the enclosure in W

Power dissipated by drive: see pages 249 and 250 (mounting in an enclosure or flush-mounting in an enclosure).

Add the power dissipated by the other equipment components.

##### Useful heat dissipation surface of enclosure S (m<sup>2</sup>)

(sides + top + front panel if wall-mounted)

$$S = \frac{K}{R_{th}}$$

K = thermal resistance per m<sup>2</sup> of the enclosure

For a metal enclosure:

- K = 0.12 with internal fan
- K = 0.15 without fan

**Note:** Do not use insulated enclosures, as they have a poor level of conductivity.

#### Installation recommendations

Depending on the conditions in which the drive is to be used, its installation will require certain precautions and the use of appropriate accessories.

Install the unit vertically:

- Avoid placing it close to heating elements
- Leave sufficient free space to ensure that the air required for cooling purposes can circulate from the bottom to the top of the unit.

#### ATV 61W●●●N4, ATV 61W●●●N4C

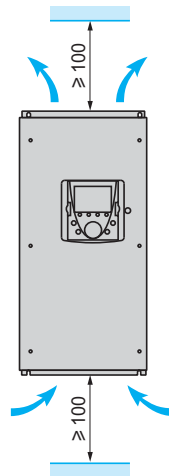

#### Mounting

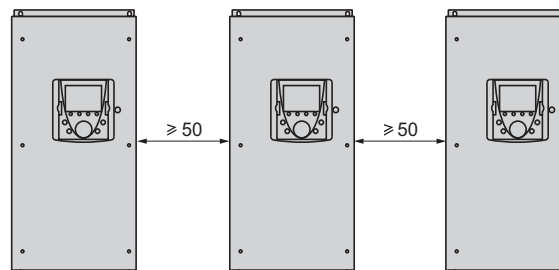

#### Derating curves for ATV 61WD15N4...WD90N4, ATV 61WD15N4C...WD90N4C

ATV 61W075N4...WU30N4, ATV 61W075N4C...WU30N4C

ATV 61U40N4...U55N4, ATV 61U40N4C...U55N4C

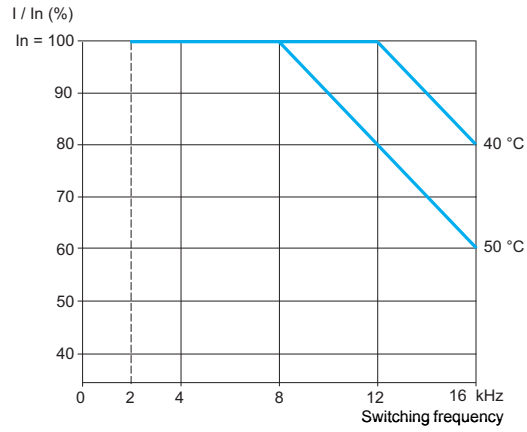
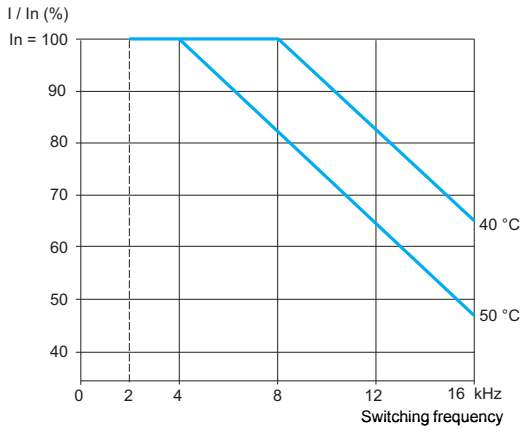

#### ATV 61U75N4...D11N4, ATV 61U75N4C...D11N4C

#### ATV 61WD15N4...WD22N4, ATV 61WD15N4C...WD22N4C

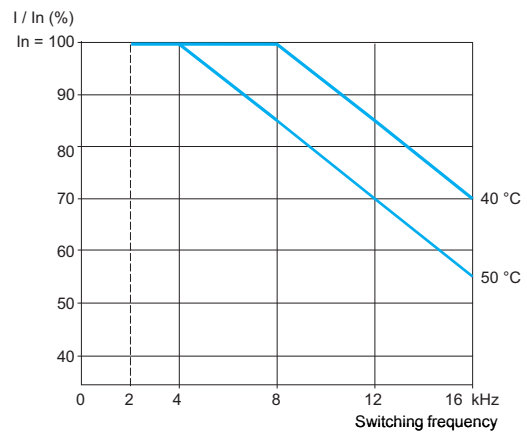
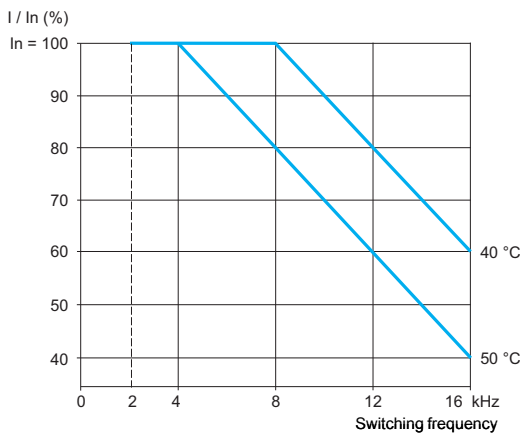

#### ATV 61WD30N4, ATV 61WD30N4C

#### ATV 61WD37N4...WD90N4, ATV 61WD37N4C...WD90N4C

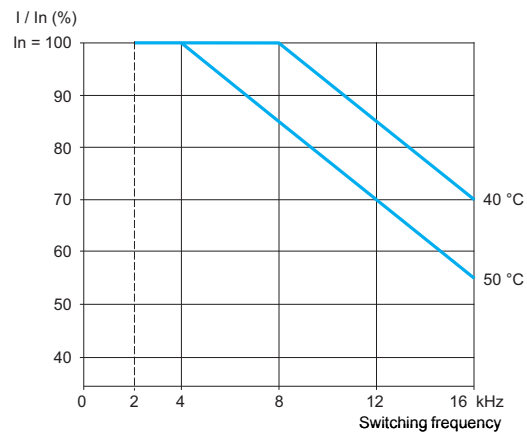
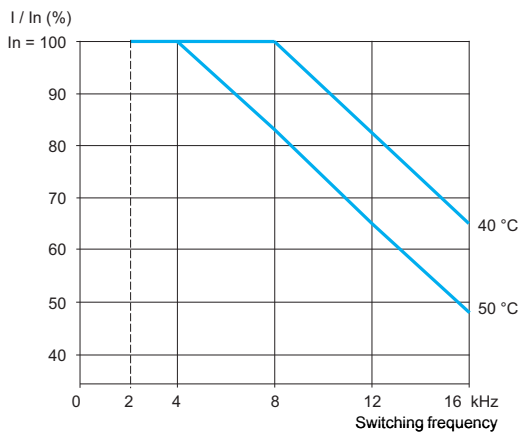



<b>Summary of functions</b>	
<b>Remote graphic display terminal functions</b>	
Description	page 256
Navigation	page 257
Password	page 257
<b>Integrated 7-segment display terminal</b>	
Presentation	page 258
<b>Setup</b>	
Simply Start menu	page 258
Programming using macro-configurations	page 259
MONITORING menu	page 260
<b>Configuration and settings</b>	
Presentation	page 260
<b>Operation</b>	
Presentation	page 260
<b>Maintenance and diagnostics</b>	
Response to faults or alarms	page 261
Fault log and help	page 261
IDENTIFICATION menu	page 261
Test functions	page 261
Oscilloscope function	page 261
<b>Controlling the drive</b>	
Via the drive I/O	page 262
Via the remote graphic display terminal	page 262
Via a communication network	
- I/O profile	page 263
- CiA 402 profile	page 263
- CIP profile	page 263
<b>Functions designed specifically for pump and fan applications</b>	
Motor control profiles	
- Energy saving ratio	page 264
- Quadratic ratio (Kn <sup>2</sup> )	page 264
PID regulator	
- Internal references	page 264
- Preset PID references	page 264
- PID feedback	page 265
- PID feedback supervision	page 265
- Sleep/Wake-up	page 265
- Sleeping on the basis of flow detection	page 265
- Alarms	page 265
- Predictive speed reference	page 265
- Auto/Man.	page 265
Forced operation	page 265
Flow limitation	page 265
<b>Other application functions</b>	
2-wire control	
- State detection	page 266
- Transition detection	page 266
- Forward operation as priority	page 266
3-wire control	page 266
Phase rotation	page 266
Ramps	
- Time	page 266
- Profile (linear, S, U or customized)	page 267
- Switching	page 267
- Automatic adaptation	page 267
Preset speeds	page 268
Jog operation	page 268
Limiting low speed operating time	page 268

### Summary of functions (continued)

#### Other application functions (continued)

Motor control types		
- Sensorless flux vector control		page 269
- 2-point vector control		page 269
- Voltage/frequency ratio		page 269
- Synchronous motor		page 269
Motor overvoltage limiting		page 269
Auto-tuning		page 269
Switching frequency, noise reduction		page 269
Motor fluxing		page 270
Output contactor command		page 270
Stop on thermal alarm		page 270
Uncontrolled output cut		page 271
+/- speed		
- Single action buttons		page 271
- Double action buttons		page 271
- Reference saving		page 272
- Around a reference		page 272
Automatic catching of a spinning load with speed detection		page 272
Undervoltage management		page 273
Braking balance		page 273
Braking resistor thermal protection		page 273
Parameter set switching		page 274
Motor or configuration switching		page 274
Reference switching		page 274
Operations on references		
- Summing inputs		page 275
- Subtraction inputs		page 275
- Multiplication inputs		page 275
Torque limit		page 276
Torque or current limit detection		page 276
Current limit		page 276
Reference saving		page 277
Stop types		
- Freewheel stop		page 277
- Fast stop		page 277
- Fastest possible stop		page 277
- DC injection stop		page 277
Motor thermal protection		page 278
Drive thermal protection		page 278
IGBT thermal protection		page 278
Machine protection		page 278
Configuring the drive's fault response		page 279
Resetting resettable faults		page 279
General reset (disables all faults)		page 279
Automatic restart		page 280
PTC probe protection		page 280
IGBT testing		page 280
Resetting operating time to zero		page 280
External fault		page 280
Line contactor command		page 281
Forced local mode		page 281

PF107498



### Remote graphic display terminal functions

The display terminal is attached to the front of the drive. It includes the integrated 7-segment display terminal for drives supplied without a graphic display terminal or for ATV 61H●●Y drives.

■ **Description**

□ **Description of graphic display terminal**

- 1 Graphic display:
  - 8 lines, 240 x 160 pixels
  - Large digits that can be read from 5 m away
  - Supports display of bar charts
- 2 Assignable function keys F1, F2, F3, F4:
  - Dialogue functions: Direct access, help screens, navigation
  - Application functions: "Local/Remote", preset speed
- 3 "STOP/RESET" key: Local control of motor stop/fault reset
- 4 "RUN" key: Local control of motor operation
- 5 Navigation button:
  - Press: Saves the current value (ENT)
  - Turn ±: Increases or decreases the value, or goes to the next or previous line
- 6 "FWD/REV" key: Reverses the direction of rotation of the motor
- 7 "ESC" key: Aborts a value, a parameter or a menu to return to the previous selection

**Note:** Keys 3, 4 and 6 can be used to control the drive directly.

□ **Description of graphic display unit**

- 1 Display line. Its content can be configured; the factory settings show:
  - The drive status (e.g. RUN)
  - The active control channel (e.g. "Term": terminals)
  - The frequency reference
  - The control type (e.g. LOC/REM)
- 2 Menu line. Indicates the current menu or submenu.
- 3 Area displaying menus, submenus, parameters, values, bar charts, in the form of a scrolling window, with a maximum of 5 lines. The line or value selected using the navigation button is displayed in reverse video (see example opposite).
- 4 Section displaying the functions assigned to the F1 to F4 keys and aligned with them, for example:
  - >>: Horizontal scrolling to the right, or proceeding to the next menu or submenu, or, in the case of a value, going to the next digit down, displayed in reverse video (see example opposite)
  - <<: Horizontal scrolling to the left, or proceeding to the previous menu or submenu, or, in the case of a value, going to the next digit up, displayed in reverse video
  - T/K: Local/Remote function assigned to the F4 key
  - HELP: Contextual help
  - Code: Displays the selected parameter code
  - Other functions (application functions) can be assigned to these keys via the 1.6 COMMAND menu.
- 5  : Means that this display window does not scroll further down  
 : Means that this display window can scroll further down
- 6  : Means that this display window can scroll further up  
 : Means that this display window does not scroll further up

SS4786

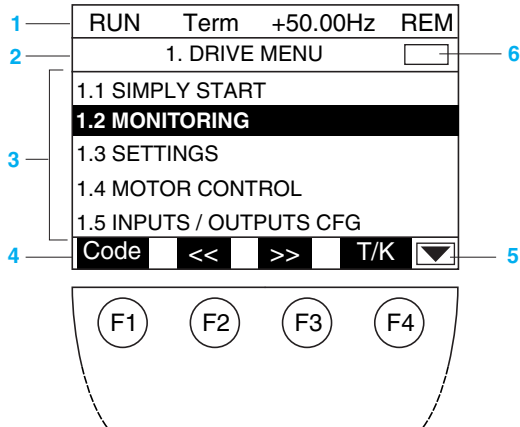

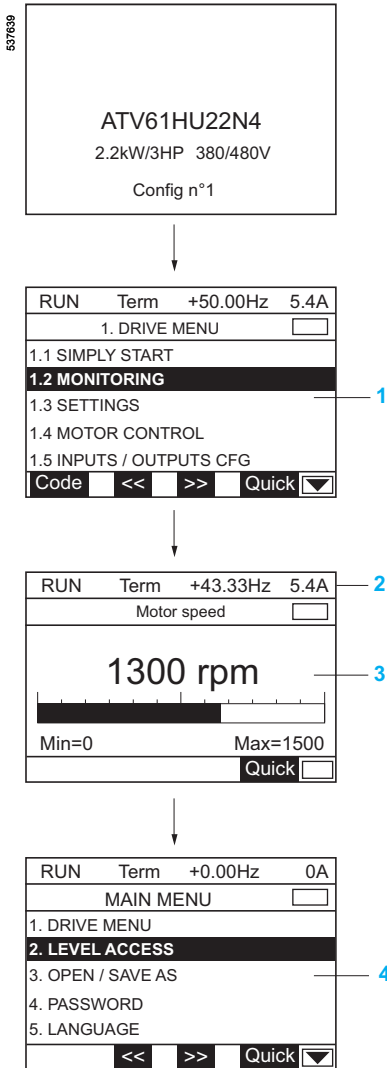

### Remote graphic display terminal functions (continued)

#### ■ Navigation: Accessing menus and parameters

##### Structure of main menus:

##### 1 Drive menu:

Menu	Function
1.1 SIMPLY START	Simplified menu for a quick start
1.2 MONITORING	Displays current values for motor, inputs/outputs and communication (control words, status words, etc.)
1.3 SETTINGS	Accesses the adjustment parameters, which can be modified during operation
1.4 MOTOR CONTROL	Accesses the motor parameters, including adjustment of motor control profiles
1.5 INPUTS/OUTPUTS CFG	Configures the I/O and transforms signals
1.6 COMMAND	Configures the command and reference channels
1.7 APPLICATION FUNCT.	Configures the application functions (preset speeds, PID regulator, etc.)
1.8 FAULT MANAGEMENT	Configures the fault management process
1.9 COMMUNICATION	Configures the communication networks
1.10 DIAGNOSTICS	Provides diagnostics for motor and drive, integrated test procedures, fault log
1.11 IDENTIFICATION	Identifies the drive and internal options
1.12 FACTORY SETTINGS	Restores factory settings (completely or by parameter group)
1.13 USER MENU	Accesses the parameters selected by the user
1.14 PROGRAMMABLE CARD	Accesses the parameters for the multi-pump card or the Controller Inside programmable card

##### 2 Display line

3 Display screen: Displays values in the form of bar charts or digital values, depending on the custom settings.

##### 4 Main menu:

Menu	Function
1. DRIVE MENU	See above (1 Drive menu)
2. ACCESS LEVEL	4 access levels: basic, limited, advanced, expert
3. OPEN/SAVE AS	Transfers files between the graphic display terminal and the drive
4. PASSWORD	Provides password protection for the configuration
5. LANGUAGE	Choice of six languages available (English, German, Spanish, French, Italian and Chinese)
6. MONITORING CONFIG.	Customizes the display line 2 and the display screen 3 (bar charts, digital values)
7. DISPLAY CONFIG.	Configures how parameters are displayed: customization, selection for User menu, visibility, accessibility

#### ■ Password

Altivar 61 drives allow individual parameters to be selected for password protection. Rights can be set for save operations and for loading the configuration.

### Integrated 7-segment display terminal

ATV 61●●●●M3, ATV 61HD11M3X...HD45M3X and ATV 61H075N4...HD75N4 drives can be supplied without a graphic display terminal. In this case, they are equipped with an integrated 7-segment display terminal.

This is used to:

- Display status and faults
- Access and modify parameters

ATV 61H●●●Y drives are equipped as standard with an integrated 7-segment display terminal.

### Setup

The Altivar 61 drive is supplied ready for use for most applications. When the drive is switched on, the menus for setting the language and access level appear automatically.

#### ■ Simply Start menu

By accessing the Simply Start menu directly it is possible to:

- Pre-program the drive for an application:
  - By selecting the relevant macro-configuration
  - 2-wire/3-wire control
- Benefit from optimum motor performance:
  - Enter data from the motor rating plate
  - Auto-tuning
- Protect the motor by setting the drive's integrated electronic thermal overload relay

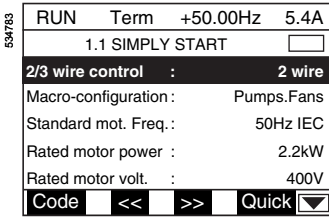

Simply Start menu

### Start-up (continued)

#### ■ Programming using macro-configurations

Programming using macro-configurations offers the choice of five options corresponding to the various business areas and applications:

- Start/stop
- General use
- PID regulation
- Communication network connectivity
- Pumps and fans

Choosing one of these macro-configurations automatically assigns the functions, parameters and I/O, even in the case of option cards. Although the configuration is preset, it can still be modified, if necessary.

The "Pumps.Fans" macro-configuration is set as the factory configuration. The preset functions for each macro-configuration are given in the table below.

Type of macro-configuration		Start/stop	General use	PID regulation	Communication network connectivity	Pumps and fans
<b>Altivar 61 drive I/O</b>						
AI1		Ref. 1 channel	Ref. 1 channel	PID reference	Ref. 2 channel Ref. 1 channel via the bus	Ref. 1 channel
AI2		Not assigned	Summing ref. 2	PID feedback	Not assigned	Ref. 1B channel
AO1		Not assigned	Not assigned	Not assigned	Not assigned	Not assigned
2-wire	LI1	Forward	Forward	Forward	Forward	Forward
	LI2	Fault reset	Reverse	Fault reset	Fault reset	Not assigned
	LI3	Not assigned	JOG	PID integral reset	Ref. 2 switching	Ref. 1B switching
	LI4	Not assigned	Fault reset	2 preset PID ref.	Forced local	Fault reset
	LI5	Not assigned	Torque limit	4 preset PID ref.	Not assigned	Not assigned
	LI6	Not assigned	Not assigned	Not assigned	Not assigned	Not assigned
3-wire	LI1	Stop	Stop	Stop	Stop	Stop
	LI2	Forward	Forward	Forward	Forward	Forward
	LI3	Fault reset	Reverse	Fault reset	Fault reset	Not assigned
	LI4	Not assigned	JOG	PID integral reset	Ref. 2 switching	Ref. 1B switching
	LI5	Not assigned	Fault reset	2 preset PID ref.	Forced local	Fault reset
	LI6	Not assigned	Torque limit	4 preset PID ref.	Not assigned	Not assigned
R1		Faulty	Faulty	Faulty	Faulty	Faulty
R2		Not assigned	Not assigned	Not assigned	Not assigned	Drive running
<b>I/O extension card I/O</b>						
2-wire	LI7	Not assigned	Not assigned	Not assigned	Not assigned	Not assigned
3-wire	LI7	Not assigned	Not assigned	Not assigned	Not assigned	Not assigned
LI8 to LI14		Not assigned	Not assigned	Not assigned	Not assigned	Not assigned
LO1 to LO4		Not assigned	Not assigned	Not assigned	Not assigned	Not assigned
R3/R4		Not assigned	Not assigned	Not assigned	Not assigned	Not assigned
AI3, AI4		Not assigned	Not assigned	Not assigned	Not assigned	Not assigned
RP		Not assigned	Not assigned	Not assigned	Not assigned	Not assigned
AO2		Motor current	Motor current	Motor current	Motor current	Motor current
AO3		Not assigned	Not assigned	PID output	Not assigned	Not assigned
<b>Graphic display terminal keys</b>						
F1 key		Not assigned	Not assigned	Not assigned	Not assigned	Not assigned
F2, F3 keys		Not assigned	Not assigned	Not assigned	Not assigned	Not assigned
F4 key		T/K (control via graphic display terminal)	T/K (control via graphic display terminal)	T/K (control via graphic display terminal)	T/K (control via graphic display terminal)	T/K (control via graphic display terminal)

### Start-up (continued)

#### ■ MONITORING menu

The MONITORING menu can be used to display commands, the operation of the motor and the application via the drive, its I/O or the communication network connections.

52169

RUN	Term	+43.33Hz	5.4A
1.2 MONITORING			
Frequency Ref. :		43.3 Hz	
Motor current :		5.4 A	
Motor speed :		1300 rpm	
Motor thermal state :		80 %	
Drv thermal state :		85 %	
Code	<<	>>	Quick

Displaying physical values

RUN	Term	+50.00Hz	80A
Logic input map			
1	PR	LI1	LI2
0		LI3	LI4
1	LI7	LI8	LI9
0		LI10	LI11
		LI12	LI13
		LI14	
Code	<<	>>	Quick

Logic input map

RUN	Mod.	+50.00Hz	5.4A
COMMUNICATION MAP			
Cmd channel :		Modbus	
Cmd Value :		ABCD Hex	
Active ref. channel :		CANopen	
Frequency ref. :		+50.00 Hz	
ETA status word :		2153 Hex	
Code	<<	>>	Quick

Communication map

This menu can be used, among other things, to display alarm groups, thermal states and electrical values, such as:

- The electrical power consumed by the drive
- The drive's cumulative electrical power, etc.

### Configuration and settings

The SETTINGS menu can be used to configure all the drive's settings.

Activating a function automatically provides access to the related settings on the same screen (the application functions are described on pages 264 to 281).

52164

RUN	Term	+50.00Hz	1250A
1.3 SETTINGS			
Ramp increment :		0,01	
Acceleration :		3,00 s	
Deceleration :		3,00 s	
Acceleration 2 :		5,00 s	
Deceleration 2 :		5,00 s	
Code	<<	>>	Quick

Settings screen

RDY	Term	+0.00Hz	0.0A
PRESET SPEEDS			
2 preset speeds :		LI3	
4 preset speeds :		LI4	
8 preset speeds :		LI5	
Preset speed 2 :		10.0 Hz	
Preset speed 3 :		15.0 Hz	
Code	<<	>>	Quick

Setting a function

RDY	Term	+0.00Hz	0A
ACCELERATION			
9.51 s			
Min=0,01		Max=9999	
Code	<<	>>	Quick

Configuring a value

### Operation

The display screen appears automatically every time the drive is turned on.

There are various possibilities:

- One or two bar charts are displayed
- One, two or five digital values are displayed

53125

RUN	Term	+43.33Hz	5.4A
Motor speed			
1300 rpm			
Min=0		Max=1500	
Code	<<	>>	Quick

1 bar chart

DEC	Term	+38.0Hz	10A
Output frequency			
+45.1 Hz			
Code	<<	>>	Quick

1 digital value

RUN	Term	+43.33Hz	5.4A
1.2 MONITORING			
Frequency Ref. :		43.3 Hz	
Motor current :		5.4 A	
Motor speed :		1300 rpm	
Motor thermal state :		80 %	
Drv thermal state :		85 %	
Code	<<	>>	Quick

5 digital values

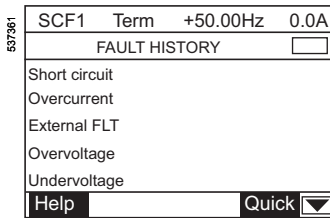

**Fault log**

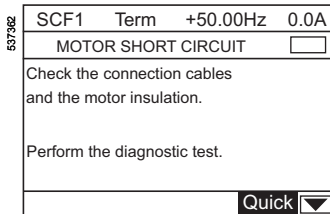

**Troubleshooting screen**

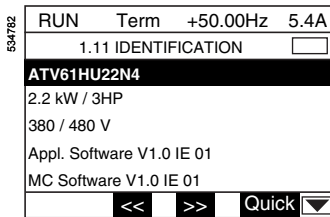

**Identification screen**

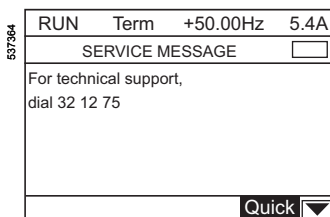

**Example of a customized message**

### Maintenance and diagnostics

New functions have been added to the Altivar 61 drive to enable it to provide quick and simple maintenance, ultimately boosting productivity:

#### ■ Response to faults or alarms

It is possible to use the alarm management or drive operation configuration functions to take corrective actions before stopping the machine.

#### ■ Fault log and help

When a fault occurs, a help screen is available to quickly identify the cause of the fault.

When a fault occurs, values such as speed, current, thermal state and timer are saved and restored in the fault log.

The last 8 faults are stored.

#### ■ IDENTIFICATION menu

The IDENTIFICATION menu can be used to display the relevant serial numbers and software versions, thereby helping to manage the equipment base. This information, also available with the PowerSuite software workshop, can be exported to other database-type software applications.

#### ■ Test functions

The Altivar 61 drive includes the following test functions:

- Identifying any motor short-circuit before start-up
- Running, via the graphic display terminal or PowerSuite software workshop, automatic procedures during maintenance operations to test:
  - The motor
  - The drive power components

The test results are shown on the graphic display terminal or using the PowerSuite software workshop.

It is also possible to write and read messages in the drive using the graphic display terminal or the PowerSuite software workshop.

#### ■ Oscilloscope function

The Altivar 61 drive has an oscilloscope function, which produces traces that can be viewed using the PowerSuite software workshop.

The PowerSuite software workshop can also be used to carry out remote diagnostics via modem.



### Controlling the drive

#### ■ Via the drive I/O

Control signals are transmitted via cable to the I/O. Functions are assigned to logic inputs, analog inputs, etc.

A logic input can be assigned to more than one function. This means that two functions can be controlled using a single signal, thereby limiting the number of inputs required.

The Altivar 61 drive I/O can be configured independently from each other. For instance:

- A time delay can be applied when it comes to reading the logic inputs, so as to avoid any bounce-back from certain switches
- Transforming incoming signals on the analog inputs can help the drive adapt fully to the control devices and applications:
  - Minimum and maximum values for the input signal
  - Input filtering in order to eliminate unwanted interference from the signals received
  - Magnifying glass effect through delinearizing the input signal in order to increase the precision with low amplitude signals
  - "Pedestal" and "Deadband" functions for signals in order to prevent low speed operations which can have an adverse effect on the application
  - "Mid-point" function, which can be used from a unipolar input signal to obtain a bipolar output signal to control the speed and direction of rotation
- Transforming analog outputs which transfer information sent by the drive to other devices (display units, drives, PLCs, etc.):
  - Voltage or current output signal
  - Minimum and maximum values for the output signal
  - Output signal filtering

Logic outputs can be delayed on activation and deactivation. The output state when the signal is active can also be configured.

The frequency control signals are also transformed by the drive:

- Signal frequency minimum and maximum values (30 kHz on the extended I/O card's RP input)

#### ■ Via the remote graphic display terminal

The rotation commands and references (speed or PID) can be controlled via the graphic display terminal. Some application functions can also be assigned to the function keys F1, F2, F3 and F4 on the graphic display terminal. It is possible to manage a change in command and/or reference source (bumpless function) in different ways.

For example: Two options are offered when switching from control via the terminals to control via the graphic display terminal:

- Stop the Altivar 61 drive, or
- Continue operation with a copy of the direction of rotation and reference

### Controlling the drive (continued)

#### ■ Via a communication network

##### □ I/O profile

The I/O profile, which is quick and easy to use, can be used to control the Altivar 61 drive via the communication network, in the same way as via the I/O terminals. When commands are sent via a network they are written in a control word. This word behaves like virtual terminals containing logic inputs. Application functions can be assigned to the bits of this word. More than one function can be assigned to the same bit.

The commands and references can come from different sources, such as the terminals, graphic display terminal or communication networks. Each source can be set or switched individually using logic inputs or control word bits.

The I/O profile is supported by all integrated communication ports (Modbus, CANopen), as well as by all the communication cards available (Modbus TCP, Fipio, PROFIBUS DP, etc.).

##### □ CiA 402 profile (Device Profile for Drives and Motion Control)

This profile, from the CiA (CAN in Automation) organization, describes standard functions, parameters and operation for variable speed drives. This standard is an extension of the Drivocom profile. The Altivar 61 drive complies with the CiA 402 standard and it supports the following 2 modes in this profile: separate and not separate.

##### Separate mode

The Start/Stop commands and references can come from different sources. For example, the speed reference is transmitted by the Modbus TCP network and the Start/Stop commands are transmitted by logic signals wired on the terminals.

Each source can be set or switched individually using logic inputs or control word bits.

##### Not separate mode

The Start/Stop commands and references (speed, torque, PID, etc.) come from the same source (e.g. the CANopen machine bus).

It is possible to replace this source by another one, using a logic input or control word bit.

The CiA 402 profile is supported by all integrated communication ports (Modbus, CANopen), as well as by all the communication cards available (Modbus TCP, Fipio, PROFIBUS DP, etc.).

##### □ CIP profile

The CIP profile is supported by the DeviceNet communication card.

**Functions designed specifically for pump and fan applications**

- **Motor control profiles**
- **Energy saving ratio**  
This control type makes it possible to optimize the energy consumed based on the load applied to the machine.
- **Quadratic ratio (Kn<sup>2</sup>)**  
This control type is optimized for centrifugal pumps and fans.
- **PID regulator**  
This is used to regulate a process with a reference and feedback provided by a sensor.

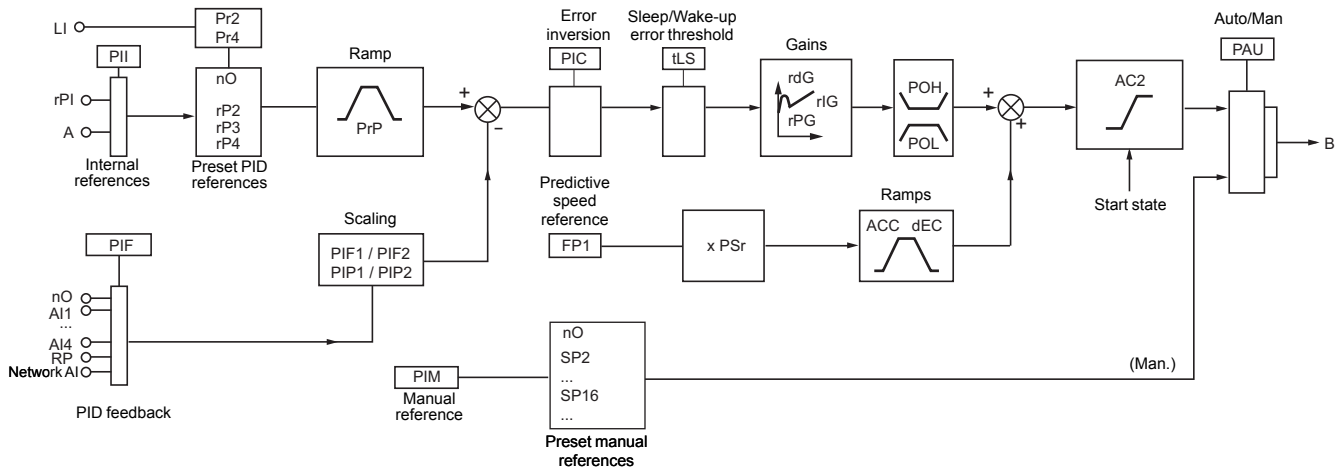

ACC: Acceleration; dEC: Deceleration; LI: Logic inputs; B: Speed reference

□ **Internal references**

- rPI: Reference transmitted by the graphic display terminal or a communication network.
  - A: Reference given by Fr1 or Fr1b with the summing, subtraction and multiplication functions, as appropriate.
- The "PII" parameter is used to choose between these two references.

□ **Preset PID references**

2 or 4 PID references are available. The following table shows the combinations of selected PID references:

Llx (Pr4)	Lly (Pr2)	Reference
0	0	rPI or A
0	1	rP2
1	0	rP3
1	1	rP4

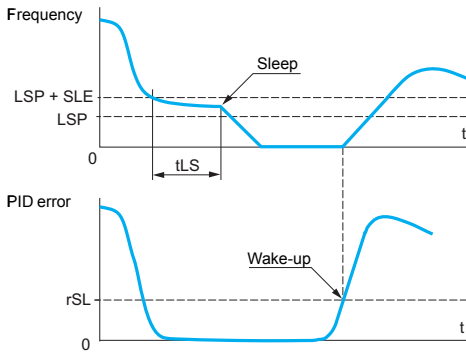

LSP: Low speed  
 SLE: Adjustable restart threshold  
 tLS: Maximum operating time at low speed  
 rSL: Restart error threshold

Example of the "sleep/wake-up" function in operation

### ■ PID regulator (continued)

#### □ PID feedback

PID feedback can be assigned to one of the analog inputs (AI1 to AI4) or the frequency control input (RP) depending on the option cards present. It can also be transmitted by a communication network (network AI).

The following four functions can be used in combination with the PID regulator:

#### □ PID feedback supervision

#### □ Sleep/Wake-up

This function supplements the PID regulator, in order to avoid prolonged operation at excessively low speeds when neither useful nor desirable.

It stops the motor after a period of operation at reduced speed. The duration (parameter tLS) and speed (parameters LSP + SLE) are adjustable.

It restarts the motor if the PID error or feedback exceeds an adjustable threshold (parameters rSL or UPP depending on the threshold).

#### □ Sleeping on the basis of flow detection

This function is used in applications where zero flow cannot be detected by the sleep function alone.

#### □ Alarms

Minimum and maximum PID regulator feedback monitoring thresholds and PID regulator error monitoring threshold.

#### □ Predictive speed reference

This reference can come from the terminals (analog inputs, etc.), the graphic display terminal or a communication network.

This speed input gives an initial reference for starting.

#### □ Auto/Man.

This can be used to switch from speed regulation mode (Man.) to PID regulation mode (Auto). A logic input or control word bit is used for switching.

#### Speed regulation mode (Man.)

The manual reference is transmitted via the terminals (analog inputs, preset speeds, etc.).

With manual switching, the speed reference changes according to the ACC and dEC ramp times.

#### PID regulation mode (Auto)

In automatic mode it is possible to:

- Adapt the references and feedback to the process (transformation)
- Correct a PID inversion
- Adjust the proportional, integral and derivative gains (Kp, Ki and Kd)
- Shunt the integral
- Use the "alarm" on the logic output or display it on the graphic display terminal, if the threshold is exceeded (Max. feedback, Min. feedback and PID error)
  - Display the PID reference, PID feedback, PID error and PID output on the graphic display terminal and assign them to an analog output
  - Apply a ramp (time = PrP) to the PID reference

The motor speed is limited to between LSP and HSP.

It is displayed as process values.

### ■ Forced operation

Combined with the inhibit all faults function, this function makes it possible to force the running order in a particular direction and the reference to a configured value.

### ■ Flow limitation

This is used to limit the flow of a fluid in pump applications.

### Other application functions

#### ■ 2-wire control

This function is used to control the direction of operation by means of a stay-put contact.

It is enabled by means of 1 or 2 logic inputs (1 or 2 directions of operation).

This function is suitable for all non-reversing and reversing applications.

Three operating modes are possible:

- Detection of the state of the logic inputs
- Detection of a change in state of the logic inputs
- Detection of the state of the logic inputs with forward operation always having priority over reverse

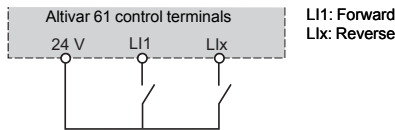

Wiring diagram for 2-wire control

#### ■ 3-wire control

This function is used to control the operating direction and stopping by means of pulsed contacts.

It is enabled by means of 2 or 3 logic inputs (1 or 2 directions of operation).

This function is suitable for all non-reversing and reversing applications.

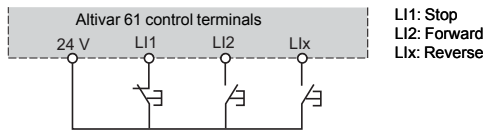

Wiring diagram for 3-wire control

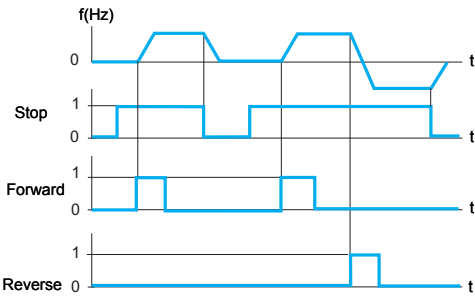

Example of operation with 3-wire control

#### ■ Phase rotation

This function can be used to reverse the direction of rotation without modifying the drive wiring.

#### ■ Ramps

##### Acceleration and deceleration ramp times

This function is used to define acceleration and deceleration ramp times according to the application and the machine dynamics.

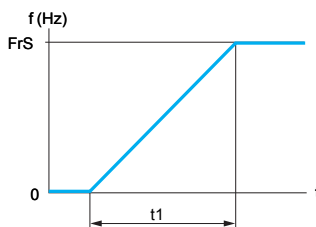

Linear acceleration ramp

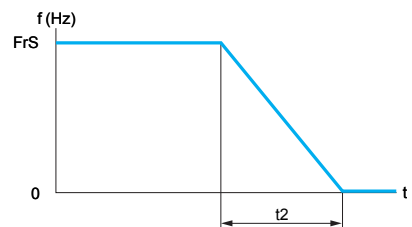

Linear deceleration ramp

FrS: Nominal motor frequency  
t1: Acceleration time  
t2: Deceleration time

t1 and t2 can be set independently from 0.01 to 9000 s (according to one of the following ramp increments: 0.01 s, 0.1 s or 1 s); Factory setting: 3 s.

RDY	Term	+0.00Hz	0.0A
RAMP			<input type="checkbox"/>
Ramp shape	:	Linear	
Ramp increment	:	0.01	
Acceleration	:	3.92 s	
Deceleration	:	0.54 s	
Ramp 2 threshold	:	0.0 Hz	
Code		Quick	<input type="checkbox"/>

Ramp settings

□ **Acceleration and deceleration ramp profiles**

These enable a gradual increase of the output frequency starting from a speed reference, following a linear profile or a preset profile.

In the case of applications involving handling, packaging and passenger transport, the use of S ramps takes up mechanical backlash and eliminates jolts, and limits “non-following” of speed during rapid transient operation of high-inertia machines. Selecting “linear”, “S”, “U” or customized profiles assigns both the acceleration and deceleration ramps.

**S ramps**

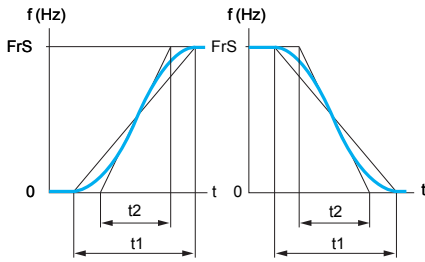

FrS: Nominal motor frequency  
 t1: Ramp time set  
 $t2 = 0.6 \times t1$   
 The rounding coefficient is fixed.

**U ramps**

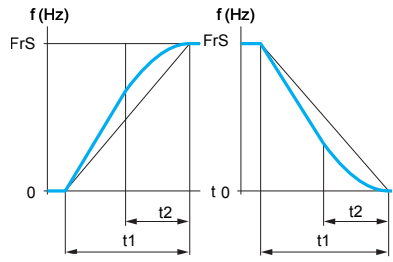

FrS: Nominal motor frequency  
 t1: Ramp time set  
 $t2 = 0.5 \times t1$   
 The rounding coefficient is fixed.

**Customized ramps**

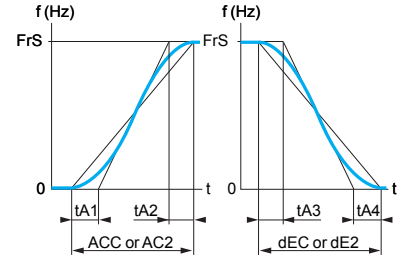

FrS: Nominal motor frequency  
 tA1: Adjustable from 0 to 100% (of ACC or AC2)  
 tA2: Adjustable from 0 to (100% - tA1) (of ACC or AC2)  
 tA3: Adjustable from 0 to 100% (of dEC or dE2)  
 tA4: Adjustable from 0 to (100% - tA3) (of dEC or dE2)  
 ACC: Acceleration ramp 1 time  
 AC2: Acceleration ramp 2 time  
 dEC: Deceleration ramp 1 time  
 dE2: Deceleration ramp 2 time

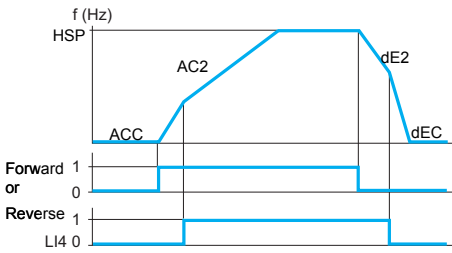

Example of switching using logic input LI4

Acceleration 1 (ACC) and deceleration 1 (dEC):  
 - Adjustment 0.01 to 9000  
 - Factory setting 3 s  
 Acceleration 2 (AC2) and deceleration 2 (dE2):  
 - Adjustment 0.01 to 9000 s  
 - Factory setting 5 s  
 HSP: High speed

□ **Ramp switching**

This function is used to switch two acceleration and deceleration ramp times, which can be adjusted separately.

Ramp switching can be enabled by:

- A logic input
- A frequency threshold
- A combination of the logic input (or a control word bit) and the frequency threshold
- A control word bit

This function is suitable for:

- Material handling with smooth starting and approach
- Machines with fast steady-state speed correction

□ **Automatic adaptation of deceleration ramp**

This function is used to automatically adapt the deceleration ramp if the initial setting is too low in relation to the load inertia. It prevents the drive from locking in the event of an overbraking fault.

When this function is active and a short deceleration time has been set, the drive optimizes the motor power supply in order to achieve a high braking torque.

This function is suitable for all applications not requiring precise stopping and not using braking resistors.

Automatic adaptation must be disabled for machines with a stop position on a ramp and using a braking resistor.

537461

RDY	Term	+0.00Hz	0.0A
PRESET SPEEDS			<input type="checkbox"/>
2 preset speeds	:	LI3	
4 preset speeds	:	LI4	
8 preset speeds	:	LI5	
Preset speed 2	:	10.0 Hz	
Preset speed 3	:	15.0 Hz	
Code	<<	>>	Quick <input type="checkbox"/>

**Preset speed settings**

**■ Preset speeds**

This function is used to switch preset speed references.

Choose between two, four or eight preset speeds.

Enabled by means of 1, 2 or 3 logic inputs.

Preset speeds can be set in increments of 0.1 Hz, from 0 Hz to 500 Hz or 1000 Hz, depending on the rating.

This function is suitable for material handling and machines with several operating speeds.

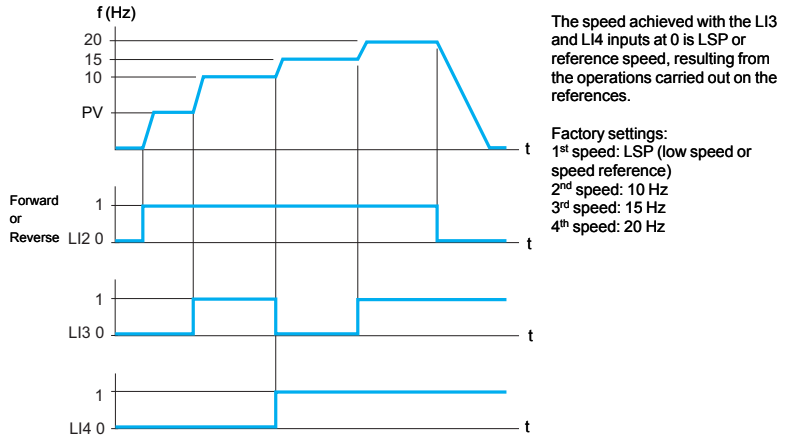

Example of operation with 4 preset speeds and 2 logic inputs

**■ Jog operation**

This function is used for pulse operation with minimum ramp times (0.1 s), limited speed reference and minimum time between 2 pulses.

It is enabled by 1 logic input and pulses issued by the operating direction command.

This function is suitable for machines with product insertion in manual mode (e.g. gradual movement of the mechanism during maintenance operations).

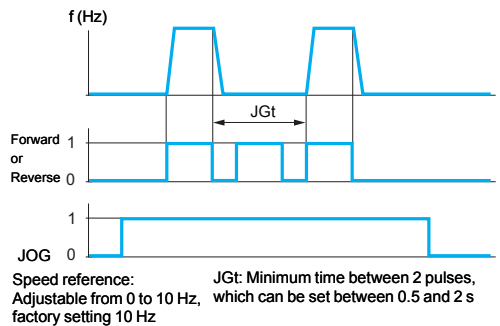

Example of jog operation

**■ Limiting low speed operating time**

The motor is stopped automatically after a period of operation at low speed (LSP) with a zero reference and a run command present.

This time can be set between 0.1 and 999.9 seconds (0 corresponds to an unlimited time period). Factory setting 0 s. The motor restarts automatically on the ramp when the reference reappears or if the run command is interrupted and then re-established.

This function is suitable for automatic stops/starts.

### ■ Motor control types

#### □ Sensorless flux vector control

In voltage mode, this control type can be used with a single motor or with motors connected in parallel.

#### □ 2-point vector control

The zone for operating at constant power can be optimized by defining an additional point in the control profile.

This function should be used with motors offering a two-part defluxing zone.

It can be used to limit the voltage at the motor terminals when the motor is being powered by a high line supply.

#### □ Voltage/frequency ratio

This control type is particularly suitable for special motors (high-speed motors, synchronized asynchronous motors, etc.). The ratio can be adjusted by 2 or 5 points and used to achieve output frequencies of up to 1000 Hz.

#### □ Synchronous motor

This control type is exclusively reserved for open loop control of synchronous permanent magnet motors with sinusoidal electromotive force (EMF).

### ■ Limiting motor overvoltage

The Altivar 61 drive inverter bridge control can be used to limit overvoltage at the motor terminals to twice the voltage of the DC bus (stressless PWM). This function is useful in cases where long lengths of cabling, rewound motors or motors in a low isolation class are involved.

### ■ Auto-tuning

Auto-tuning can be performed:

- Using a dialogue tool (graphical display terminal, PowerSuite software workshop, integrated 7-segment display terminal)
- Via a communication network
- Automatically on every power-up
- By enabling a logic input

Auto-tuning is used to optimize application performance.

In Flux Vector Control mode (FVC closed loop with voltage control), certain parameters are measured periodically.

Saving the motor thermal state can help to compensate exactly for the motor resistors, even after the drive has been switched off.

### ■ Switching frequency, noise reduction

Adjusting the switching frequency is used to reduce the noise generated by the motor for any application requiring a low level of noise.

The switching frequency is modulated randomly in order to avoid resonance. This function can be disabled if it causes instability.

High frequency switching of the intermediate DC voltage can be used to supply the motor with a current wave that has little harmonic distortion.

The switching frequency can be adjusted during operation to reduce the noise generated by the motor.

Value: 1 to 16 kHz depending on the rating



### ■ Motor fluxing

This function is used to obtain rapid high torque on start-up; magnetic flux needs to be already established in the motor.

In continuous mode, the drive automatically establishes the flux when it is powered up.

In non-continuous mode:

- If a logic input or control word bit is assigned to the motor fluxing command, flux is established when the command is confirmed.
- If neither a logic input nor a control word bit has been assigned, or if they are not active when a run command is given, fluxing occurs when the motor starts.

Fluxing is accelerated if a current higher than the nominal motor current is applied, then it is set to the value of the motor magnetizing current.

### ■ Output contactor command

This allows the drive to control a contactor located between the drive and the motor. The request to close the contactor is made when a run command appears.

The request to open the contactor is made when there is no current in the motor.

**Note:** If a DC injection braking function has been configured it should not be left operating too long in stop mode, as the contactor only opens at the end of braking.

### ■ Stop on thermal alarm

This can be used to:

- Allow a movement to end before taking account of a thermal fault. Two adjustable thresholds are used to define the thermal state levels outside of which a stop will be triggered.
- Prevent a new run command from being accepted as long as the drive and motor temperatures are not less than 100%.

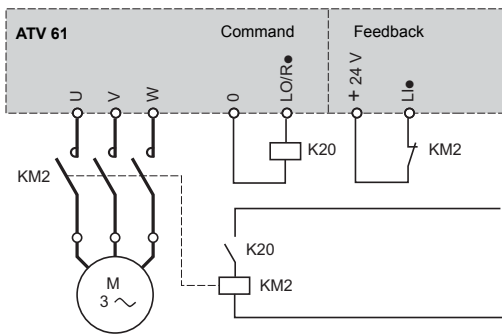

Output contactor command

RDY	Term	+0.00Hz	0.0A
+/- SPEED			<input type="text"/>
+ speed assign. :		LI3	
- speed assign. :		LI4	
Ref. saved :		RAM	
Code	<input type="text"/>	Quick	<input type="button" value="v"/>

+/- speed function settings

### ■ Uncontrolled output cut

It is possible to configure output phase loss protection, which will allow the drive or motor circuit to be broken without the drive becoming locked in fault mode and facilitate a smooth restart after the motor has been reconnected. The output phase loss may also lock the drive, depending on the configuration.

### ■ +/- speed

This function is used to increase or decrease a speed reference by means of 1 or 2 logic inputs, with or without the last reference being saved (motorized potentiometer function).

This function is suitable for centralized control of a machine with several sections operating in one direction only, or for control of a material handling crane with two operating directions using a pendant control station.

Two types of operation are available:

- Use of single-action buttons: 2 logic inputs are required in addition to the operating direction(s).
- Use of double-action buttons: Only 1 logic input assigned to + speed is required.

**Use of single-action buttons:** 2 logic inputs are required in addition to the operating direction(s).

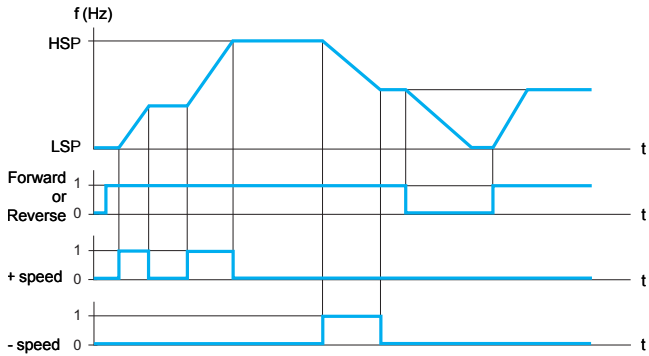

LSP: low speed; HSP: high speed

Example of "+/- speed" with 2 logic inputs, single-action buttons and reference saving

**Use of double-action buttons:** Only 1 logic input assigned to + speed is required.

Logic inputs:

Forward	Reverse	" + speed "	Released (- speed)	1 <sup>st</sup> press (speed maintained)	2 <sup>nd</sup> press (+ speed)
			Forward button	a	a and b
a and c: 1 <sup>st</sup> press b and d: 2 <sup>nd</sup> press			Reverse button	c	c and d

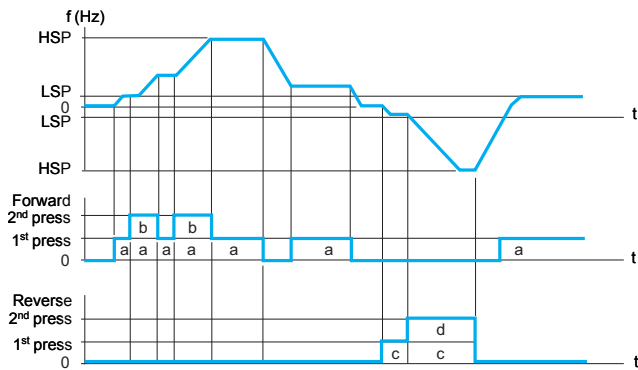

LSP: low speed; HSP: high speed

Example with double-action buttons and 1 logic input

**Note:** This type of +/- speed control is incompatible with 3-wire control.

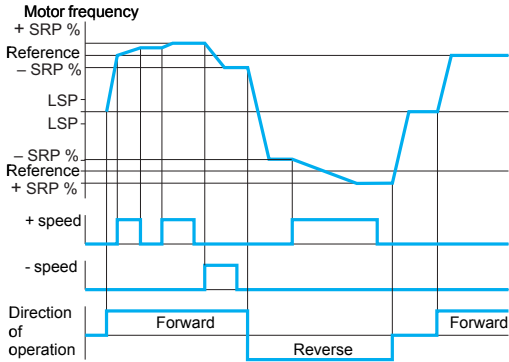

Example of +/- speed around a 2-wire control reference

**Reference saving**

This function is associated with “+/- speed” control.

It is used to read and save the last speed reference prior to the loss of the run command or line supply. The saved reference is applied the next time a run command is received.

**+/- speed around a reference**

The reference is given by Fr1 or Fr1b, including, if relevant, the summing, subtraction and multiplication functions, as well as the preset speeds.

At the run command the drive goes to the reference by following the acceleration and deceleration ramps (pressing +/- speed makes the speed vary around this reference according to acceleration ramp 2 and deceleration ramp 2).

+ or - speed variation around the reference is limited to a percentage of the reference (SRP parameter). When operation has stopped, the amended reference is not saved.

The maximum total reference is always limited by high speed (HSP parameter) and the minimum reference (LSP parameter).

**Automatic catching of a spinning load with speed detection (“catch on the fly”)**

This function is used to restart the motor smoothly after one of the following events, provided the run command is still present:

- Loss of line supply or simple power off
- Fault reset or automatic restart
- Freewheel stop

On disappearance of the event, the effective speed of the motor is detected in order to restart on a ramp at this speed and return to the reference speed. The speed detection time can reach 0.5 s.

This function is suitable for machines for which the motor speed loss is negligible during a power failure (high-inertia machines such as centrifuges, etc.).

### ■ Undervoltage management

Depending on the application, it is possible to configure the Altivar 61's response to undervoltages or power failures.

If undervoltage occurs:

- The Altivar 61 drive can continue operating with undervoltage levels up to -50% (adjustable threshold).
- If the drive locks as a result, management of the fault relay can be configured (open or not). If the fault relay does not open, an alarm is shown.

The Altivar 61 drive can also be configured to prevent the drive locking (with an alarm):

- Controlled stop according to the type of stop configured
- Deceleration based on a ramp which it automatically adapts to maintain the DC bus voltage, thereby preventing the drive from locking in fault mode
- Instant IGBT (inverter bridge) loss followed by power supplied to the motor as soon as the line voltage has reappeared. This function prevents the Altivar 61 drive from being reinitialized.

### ■ Braking balance

When several drives are connected to a common DC bus, this function can be used to adjust the braking thresholds in order to balance the braking powers among the various drives or braking units.

### ■ Braking resistor thermal protection

The Altivar 61 drive incorporates thermal protection for the braking resistor if it is not equipped with a thermal switch. If the resistor thermal state is too high, an alarm can be assigned to the logic output or the drive may lock in fault mode, depending on how the function is programmed.

### ■ Parameter set switching (multi-parameter)

This function is used to switch 3 sets of 15 parameters maximum when the motor is running.

Each set can contain a different value for each of the parameters. The sets are switched using 1 or 2 logic inputs or control word bits.

This function is suitable for machines involving two or three manufacturing processes.

### ■ Motor or configuration switching (multi-motor or multi-configuration)

The Altivar 61 drive can contain up to 3 different configurations, each of which can be activated remotely, allowing it to adapt as follows:

- 2 or 3 different motors or mechanisms in multi-motor mode. In this instance, the thermal state for all the motors is calculated and saved. This means that each motor is protected thermally.
- 2 or 3 configurations for the same motor in multi-configuration mode. This function can also be used to save the current configuration in another memory zone, from which it can be retrieved.

Switching is carried out using 1 or 2 logic inputs, depending on the number of motors or configurations chosen (2 or 3).

Multi-motor and multi-configuration modes cannot be used together.

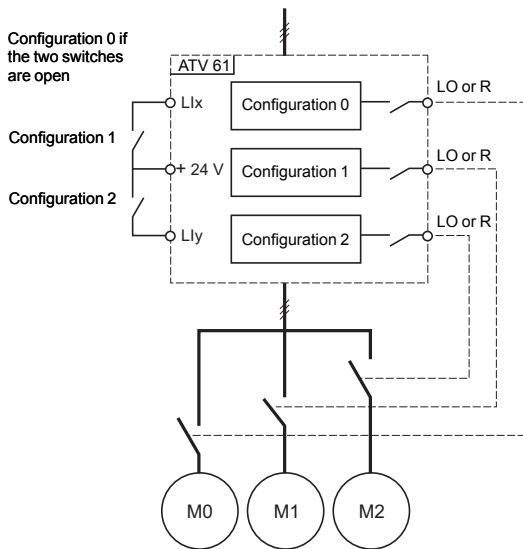

Schematic diagram for multi-motor mode

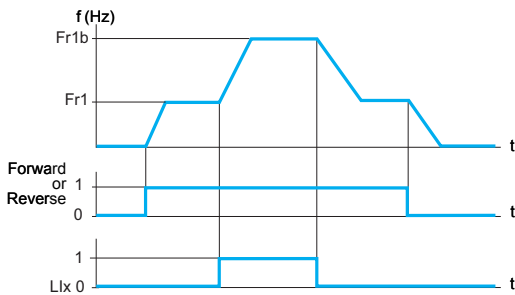

Example of reference switching

### ■ Reference switching

Switching between two references (speed, PID, etc.) can be enabled by:

- A logic input
- A control word bit

Reference 1 (Fr1) is active if the logic input (or control word bit) is at 0; reference 2 (Fr1b) is active if the logic input (or control word bit) is at 1.

References can be switched with the motor running.

Reference Fr1b, like Fr1, can originate from:

- An analog input (AI)
- A frequency control input (RP)
- The graphic display terminal
- The Modbus serial link or the CANopen machine bus
- A communication card
- The "Controller Inside" programmable card

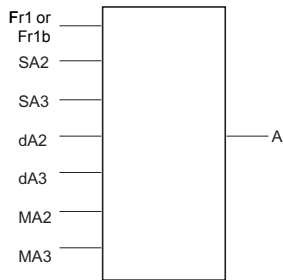

**A:** Drive reference  
**SA2, SA3:** Summing inputs  
**dA2, dA3:** Subtraction inputs  
**MA2, MA3:** Multiplication inputs

### ■ Operations on references (summing, subtraction, multiplication)

Summing, subtraction and multiplication inputs can be activated simultaneously.

The drive reference is thus:

$$\square \text{ Reference of drive A} = (\text{Fr1 or Fr1b} + \text{SA2} + \text{SA3} - \text{dA2} - \text{dA3}) \times \text{MA2} \times \text{MA3}$$

#### □ Summing inputs

These are used to add 2 to 3 references from different sources to Fr1 or Fr1b (see "Reference switching").

The references to be added are selected from all the possible types of reference.

For example:

Reference Fr1 or Fr1b from AI1

Reference SA2 from CANopen

Reference SA3 from a communication card

Reference of drive A = Fr1 or Fr1b + SA2 + SA3

#### □ Subtraction inputs

These are used to subtract 2 to 3 references from different sources from Fr1 or Fr1b (see "Reference switching").

The references to be subtracted are selected from all the possible types of reference.

For example:

Reference Fr1 or Fr1b from AI1

Reference dA2 from CANopen

Reference dA3 from a communication card

Reference of drive A = Fr1 or Fr1b - dA2 - dA3

#### □ Multiplication inputs

These are used to multiply 2 to 3 references from different sources by Fr1 or Fr1b (see "Reference switching").

The references to be multiplied are selected from all the possible types of reference.

For example:

Reference Fr1 or Fr1b from AI1

Reference MA2 from CANopen

Reference MA3 from a communication card

Reference of drive A = Fr1 or Fr1b x MA2 x MA3

### ■ Torque limit

This function is used to limit the torque in the motor and generator quadrants using separate settings.

There are two types of torque limit:

- One using a value set by a parameter
- The other using a value given by an analog input or a frequency control input

When both torque limit types are enabled it is the lowest value which is used. They can be switched using a logic input or control word bit.

This function is not available for voltage/frequency ratio type control.

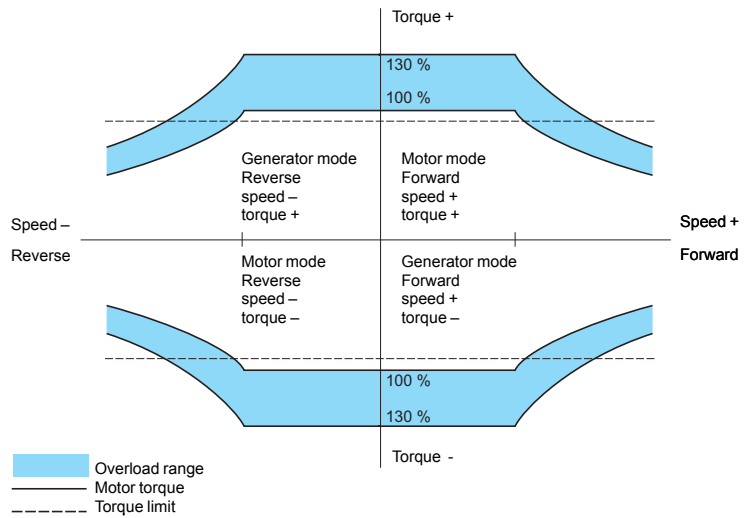

Torque limiting operates in both directions of rotation in motor or generator mode.

### ■ Torque or current limit detection

This function is used to detect when the current or torque limit has been reached. Depending on the configuration, it is possible to:

- Use an alarm to signal this
- Lock the drive after an adjustable period of time

### ■ Current limit

A second current limit can be configured between 1.1 and 1.2 times the nominal drive current and is used to limit motor overheating and torque.

Switching between the two current limits can be enabled via:

- A logic input
- A control word bit

RDY	Term	+0.00Hz	0.0A
2nd CURRENT LIMIT.			<input type="text"/>
I Limit. 2 activ.	:	LI6	
I Limit. 2 value	:	6.4 A	
Current limitation	:	7.9 A	
Code	<input type="text"/>	Quick	<input type="button" value="v"/>

Configuring current limit

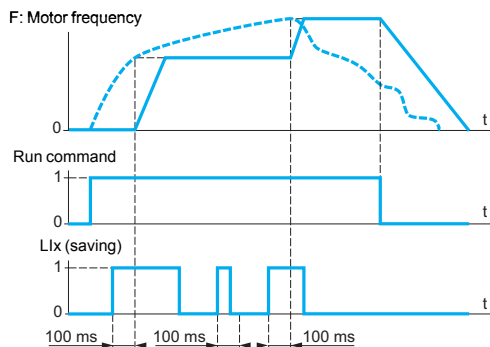

----- Analog reference

**Example of how reference saving works**

537644

RDY	Term	+0.00Hz	0.0A
STOP CONFIGURATION <input type="checkbox"/>			
Type of stop :	Ramp stop		
Freewheel assign. :	NO		
Fast stop assign. :	LI4		
Ramp divider :	0		
DC inject. assign. :	NO		
Code	Quick		<input type="button" value="v"/>

**Configuring stop types**

### ■ Reference saving

This function is used to:

- Read and save a speed reference level on the reference input using a command lasting longer than 0.1 s on a logic input
- Control the speed of several drives alternately via a single analog reference and a logic input for each drive
- Enable a line reference (serial link) on several drives via a logic input in order to synchronize movements by eliminating variations when the reference is sent. The reference is acquired 100 ms after the rising edge of the read request. No new reference is acquired until a new request is made.

### ■ Stop types

#### Freewheel stop

This stops the motor by resistive torque if the motor power supply is cut.

A freewheel stop is achieved:

- By configuring a normal stop command as a freewheel stop (on disappearance of a run command or appearance of a stop command)
- By enabling a logic input
- By activating a control word bit

#### Fast stop

This is used to achieve a braked stop with a deceleration ramp time (divided by a coefficient adjustable from 0 to 10) acceptable by the drive/motor unit without locking on an overbraking fault. If the coefficient equals 0, the motor decelerates as fast as possible.

This is used for conveyors with electrical emergency stop braking.

A fast stop is achieved:

- By configuring a normal stop as a fast stop (on disappearance of a run command or appearance of a stop command)
- By enabling a logic input
- By activating a control word bit

#### Fastest possible stop

If the ramp divider coefficient equals 0 the motor decelerates as fast as possible.

#### DC injection stop

This is used to brake high-inertia machines at low speed or maintain torque on stopping.

A DC injection stop is achieved:

- By configuring a normal stop as a DC injection stop (on disappearance of a run command or appearance of a stop command)
- By enabling a logic input
- By activating a control word bit

The DC value and the standstill braking time are adjustable.



**Motor thermal protection**

Motor thermal protection is provided by the drive:

- Directly, through PTC probes located in the motor windings
- Indirectly, via the integrated thermal relay. Indirect thermal protection is implemented by continuous calculation of its theoretical temperature rise.

The microprocessor calculates the theoretical temperature rise of the motor based on various elements:

- The operating frequency
- The current taken by the motor
- The operating time
- The maximum ambient temperature around the motor (40°C)
- The type of motor ventilation (self-cooled or force-cooled)

Thermal protection is adjustable from 0.5 to 1.2 times the nominal current, depending on the type of drive. It must be adjusted to the nominal current indicated on the motor rating plate.

**Note:** The motor thermal state memory returns to zero when the drive control section is switched off.

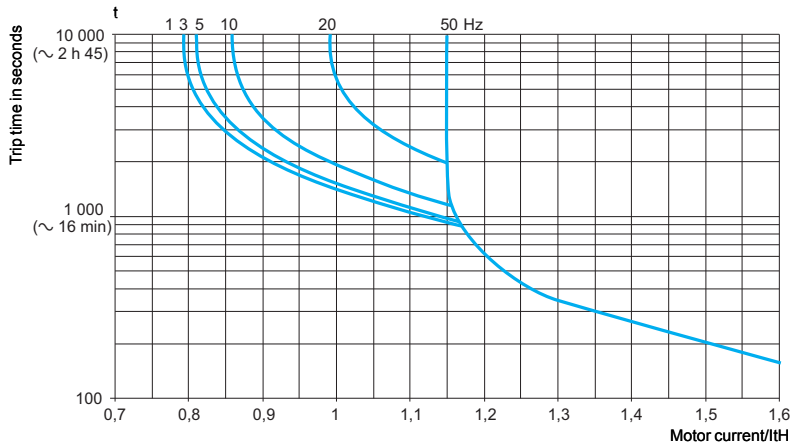

Motor thermal protection curves

- Self-cooled motors:  
The tripping curves vary with the motor frequency.
- Force-cooled motors:  
Only the 50 Hz tripping curve should be considered, whatever the motor frequency.

**Drive thermal protection**

The drive thermal protection is provided by a PTC probe mounted on the heatsink or integrated in the power module.

**IGBT thermal protection**

The drive manages the switching frequency intelligently according to the IGBT temperature.

If the drive's current rating is exceeded (e.g. the current is higher than the nominal drive current for a zero stator frequency), an alarm is displayed and a timer increments for as long the alarm is present.

**Machine protection**

This is used to detect an under- and/or overload.

537645

RDY	Term	+0.00Hz	0.0A
4-20mA LOSS <input type="checkbox"/>			
Fallback spd			
Spd maintain			<input checked="" type="checkbox"/>
Ramp stop			
Fast stop			
DC injection			
Quick <input type="button" value="v"/>			

Fault response configuration

### ■ Configuring the drive's fault response (fault management)

Different responses can be configured for the drive in the event of a resettable fault occurring:

- Freewheel stop
- The drive switches to the fallback speed
- The drive maintains the speed at which it was operating when the fault occurred until the fault disappears
- Stop on ramp
- Fast stop
- DC injection stop
- No stop (alarm activated)

### List of resettable faults:

- External fault
- Speed feedback loss
- Overspeed
- Output phase loss
- Auto-tuning fault
- 4-20 mA loss
- PTC probe
- Drive overheating
- Motor overload if the thermal state is less than 100%
- Line overvoltage
- Overbraking
- Current/torque limit
- IGBT overheating
- Communication faults (Modbus, CANopen and other communication networks)
- Process overload
- Process underload
- PI supervision
- No flow

### ■ Resetting resettable faults

This function is used to clear the last fault using a logic input, control word bit or the STOP/RESET key on the graphic display terminal. The restart conditions after a reset are the same as those of a normal power-up.

For a list of resettable faults, see "Configuring the drive's fault response".

Line supply undervoltage and input phase loss faults are reset automatically when the line supply returns to normal.

This function is suitable for applications where drives are difficult to access, such as when a drive is located on a moving part.

### ■ General reset (disables all faults)

This function inhibits all faults, including thermal protection (forced operation), which can destroy the drive.

This function is suitable for applications where restarting may be crucial (conveyor in an oven, smoke extraction system, machines with solidifying products that need to be removed).

The function is enabled by a logic input.

Fault monitoring is active if the logic input is at state 1.

All faults are reset on a change of state (  $\updownarrow$  ) of the logic input.

**Note:** Use of this function invalidates the guarantee.

### ■ Automatic restart

This function enables the drive to be restarted automatically after it has locked in fault mode, provided the relevant fault has disappeared and the other operating conditions permit a restart.

This restart is performed by a series of automatic attempts separated by increasingly longer waiting periods of 1 s, 5 s, 10 s then 1 minute for the rest.

The options for the restart process's duration are 5, 10 and 30 min., 1, 2, 3 hours and an unlimited time period.

If the drive has not restarted after the configured time, it will lock and the procedure is abandoned until it has been powered off and on again.

The faults which permit this type of restart are:

- Line overvoltage
- Motor thermal overload
- Drive thermal overload
- DC bus overvoltage
- Line phase failure
- External fault
- 4-20 mA loss
- PTC probes
- Serial link
- Current or torque limit
- Output phase loss
- Line voltage too low (For this fault, the function is always active, even if it is not configured.)
- Process overload
- Process underload
- PI supervision
- No flow
- Fault caused by CANopen machine bus, Modbus serial link or other communication networks. These faults are reset automatically as soon as the control word or frequency reference is sent to the drive.

For these types of fault, the relay configured as a fault relay remains activated if the function is configured. The speed reference and direction of operation must be maintained for this function.

This function is suitable for machines or installations which are in continuous operation or are not monitored, and where a restart will not endanger equipment or personnel in any way.

### ■ PTC probe protection

The probes can be connected directly to the drive control card or to the I/O option cards.

The way in which a temperature fault is recorded by the drive can be configured as follows:

- Permanent record
- Only recorded when the drive's power section is powered up
- Only recorded when the motor is running

### ■ IGBT testing

When enabled, this function tests every IGBT and the motor connections in order to detect a short-circuit or an open circuit. This test is run every time the drive is powered up and before each motor start.

This function must not be enabled with machines with fast cycles in order to conserve time for taking account of the run commands.

### ■ Resetting operating time to zero

The drive operating and power-on time can be reset.

### ■ External fault

This function can lead to the drive locking if a fault occurs in the machine. This fault is flagged on the drive display unit. The fault is flagged if the signal is at 1 or 0, depending on how the function is configured.

### ■ Line contactor command

This is used on each run command to close the line contactor and open it when the motor is no longer supplied with power. The drive control section must be powered by an external 24 V  $\overline{\text{---}}$  source.

This function must be used for simple sequences with a low number of Start/Stop operations (Start/Stop cycle longer than 60 seconds).

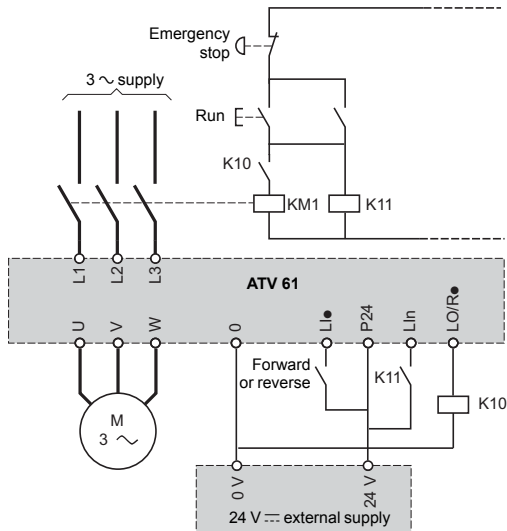

After a run command, if the line contactor is not closed the drive will lock after an adjustable period of time.

### ■ Forced local mode

Forced local mode imposes control via the terminals or graphic display terminal and disables all other control modes.

Switching to forced local mode may be activated via:

- A logic input
- A function key on the graphic display terminal

The following references and commands are available for forced local mode:

- References AI1, AI2, etc. and command via logic inputs
- Reference and command via the graphic display terminal

### Function compatibility table

**■ Configurable I/O**

The table below lists the incompatibilities between the functions and indicates the priority functions:

Stop functions have priority over run commands.

The Power Removal safety function takes priority over all other functions.

The selection of functions is limited:

- By the number of drive I/O which can be reassigned: if necessary, add an I/O extension card.
- By the incompatibility of certain functions with one another.

Functions	PID regulator	Preset speeds	JOG operation	Synchronous motor
PID regulator			■	
Preset speeds			↑	
JOG operation	■	←		
Synchronous motor				
+/- speed (1)			■	
+/- speed around a reference	■		■	
Operation on the references	■ (2)	↑	↑	
Freewheel stop				
Fast stop				
DC injection stop				■

(1) Excluding special use with reference channel Fr2.

(2) Only the multiplier reference is incompatible with the PID regulator.

(3) Priority is given to the first of these two stop modes to be activated.

■ Incompatible functions

Compatible functions

N/A

**Priority functions** (functions which cannot be active at the same time)

← The arrow indicates which function has priority.  
Example: the "Freewheel stop" function has priority over the "Fast stop" function

+/- speed (1)	+/- speed around a reference	Operation on the references	Freewheel stop	Fast stop	DC injection stop
	■	■ (2)			
		←			
■	■	←			
					■
				←	←
			↑		■ (3)
			↑	■ (3)	

534513

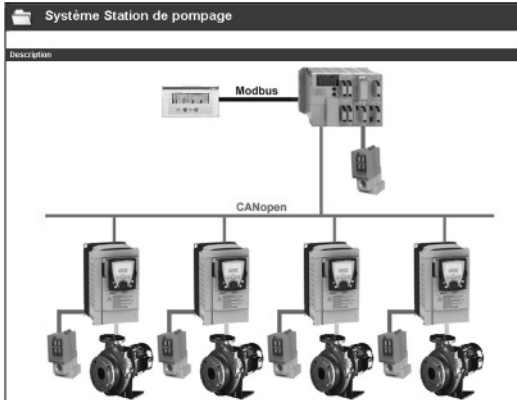

PowerSuite screen on PC

## Presentation

The PowerSuite software workshop for PC is a user-friendly tool designed for setting up control devices for the following Telemecanique brand motors:

- TeSys U starter-controllers
- TeSys T motor management systems
- Altistart soft start/soft stop units
- Altivar variable speed drives
- Lexium 05 servo drives

It includes various functions designed for setup phases such as:

- Preparing configurations
- Start-up
- Maintenance

To facilitate start-up and maintenance, the PowerSuite software workshop is compatible with the Bluetooth® wireless link.

533181

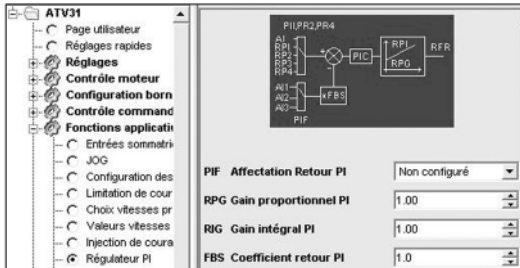

PowerSuite screen on PC  
View of PI regulator function parameters

## Functions (1)

### Preparing configurations

The PowerSuite software workshop can be used on its own to generate the device configuration, which can be saved, printed and exported to office automation software.

The PowerSuite software workshop can also be used to convert an Altivar 58 or Altivar 58F drive configuration into one that is compatible with an Altivar 71.

### Start-up

When the PC is connected to the device, the PowerSuite software workshop can be used to:

- Transfer the generated configuration
- Adjust
- Monitor. This option has been enhanced with new functions such as:
  - The oscilloscope
  - The high-speed oscilloscope (minimum time base: 2 ms)
  - The FFT (*Fast Fourier Transform*) oscilloscope
  - Display of communication parameters
- Control
- Save the final configuration

### Maintenance

To facilitate maintenance operations, the PowerSuite software workshop can be used to:

- Compare the configuration of a device currently being used with a saved configuration
- Manage the user's installed equipment base, in particular:
  - Organize the installed base into folders (electrical equipment, machinery, workshops, etc.)
  - Store maintenance messages
  - Facilitate Modbus TCP connection by storing the IP address

### User interface

The PowerSuite software workshop can be used to:

- Present the device parameters (arranged by function) in the form of illustrated views of diagrams or simple tables
- Customize the parameter names
- Create:
  - A user menu (choice of particular parameters)
  - Monitoring control panels with graphic elements (cursors, gauges, bar charts)
- Perform sort operations on the parameters
- Display text in five languages (English, French, German, Italian and Spanish). The language changes immediately and there is no need to restart the program.

572706

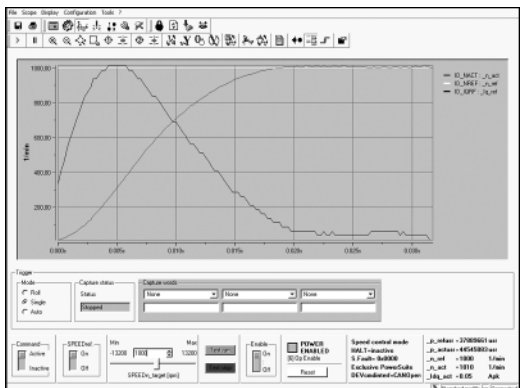

View of the FFT oscilloscope

It also features online contextual help:

- On the PowerSuite tool
- On the device functions by direct access to the user manuals

(1) Certain functions are not available for all devices. See the table of available functions, page 285.

**Functions available for the PowerSuite software workshop**

Functions not listed in the table are available for all devices.

Function available with devices	Controller	Starter-controller	Soft start/soft stop unit	Drives				Servo drive
	TeSys T	TeSys U	ATS 48	ATV 11	ATV 31	ATV 61	ATV 71	LXM 05
Monitoring	■	■	■	■	■	■	■	■
Oscilloscope	■	■	■	■	■	■	■	■
High-speed oscilloscope	■	■	■	■	■	■	■	■
FFT oscilloscope	■	■	■	■	■	■	■	■
Display of communication parameters	■	■	■	■	■	■	■	■
Control	■	■	■	■	■	■	■	■
Customization of parameter names	■	■	■	■	■	■	■	■
Creation of a user menu	■	■	■	■	■	■	■	■
Creation of monitoring control panels	■	■	■	■	■	■	■	■
Sort operation on parameters	■	■	■	■	■	■	■	■
Custom logic editor	■	■	■	■	■	■	■	■

■ Functions available  
 ■ Functions not available

**Connections (1)**

**Modbus serial link**

The PowerSuite software workshop can be connected directly to the device terminal port or Modbus network port via the serial port on the PC.

Two types of connection are possible:

- With a single device (point-to-point connection), use a VW3 A8 106 PC serial port connection kit.
- With a number of devices (multidrop connection), use the XGS Z24 interface.

**Modbus TCP communication network**

The PowerSuite software workshop can be connected to a Modbus TCP network. In this case, the devices can be accessed:

- Using a VW3 A3 310 communication card for the Altivar 61 and 71 drives
- Using a TSX ETG 100 Modbus TCP/Modbus gateway

**Bluetooth® wireless link**

The PowerSuite software workshop can communicate via a Bluetooth® radio link if the device is equipped with a Bluetooth® Modbus VW3 A8 114. The adapter plugs into the device connector terminal port or Modbus network port and has a range of 10 m (class 2).

If the PC does not feature Bluetooth® technology, use the VW3 A8 115 USB - Bluetooth® adapter.

**Remote maintenance**

A simple Modbus TCP connection is all that is required for the PowerSuite software workshop to support remote monitoring and diagnostics. When devices are not connected to the Modbus TCP network, or it is not directly accessible, various remote transmission solutions may be used instead (modem, teleprocessing gateway, etc.). Please consult your Regional Sales Office.

(1) Please refer to the compatibility table on page 287.

(2) Please refer to our specialist "Automation platform Modicon Premium and Unity - PL7 software" and "Automation platform Modicon TSX Micro - PL7 software" catalogues.

538845

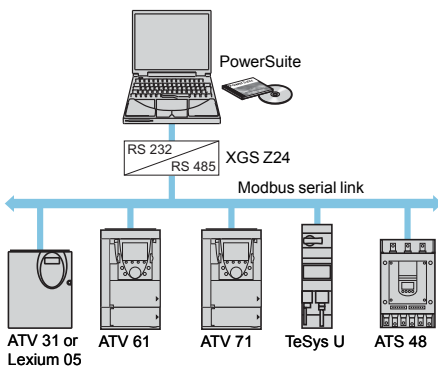

Modbus multidrop connection

538846

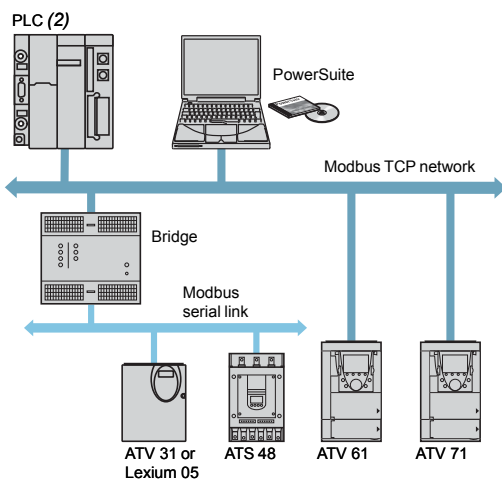

Modbus TCP connection



## PowerSuite software workshop

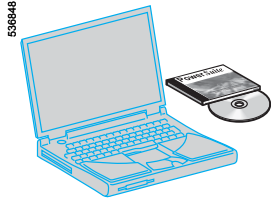

VW3 A8 104

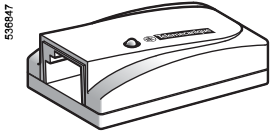

VW3 A8 114

Description	Composition	Reference	Weight kg
<b>PowerSuite CD-ROM</b>	<ul style="list-style-type: none"> <li>■ 1 program for PC in English, French, German, Italian and Spanish</li> <li>■ Variable speed drive, starter and servo drive technical manuals</li> </ul>	<b>VW3 A8 104</b>	0.100
<b>PowerSuite update CD-ROM (1)</b>	<ul style="list-style-type: none"> <li>■ 1 program for PC in English, French, German, Italian and Spanish</li> <li>■ Variable speed drive and starter technical manuals</li> </ul>	<b>VW3 A8 105</b>	0.100
<b>PC serial port connection kit</b> for point-to-point Modbus connection	<ul style="list-style-type: none"> <li>■ 1 x 3 m cable with 1 RJ45 connector on starter-controller or drive side and 1 RS 232/RS 485 converter with 1 9-way female SUB-D connector on PC side</li> <li>■ For the ATV 11 drive: 1 converter with one 4-way male SUB-D connector and 1 RJ45 connector</li> <li>■ For ATV 38/58/58F drives: 1 RJ45/9-way male SUB-D adapter</li> </ul>	<b>VW3 A8 106</b>	0.350
<b>RS 232/RS 485 interface</b> for multidrop Modbus connection	1 Modbus multidrop converter for connection to screw terminals. Requires a 24 V $\overline{\text{---}}$ (20...30 V), 20 mA power supply (2).	<b>XGS Z24</b>	0.105
<b>Modbus-Bluetooth® adapter (3)</b>	<ul style="list-style-type: none"> <li>■ 1 Bluetooth® adapter (10 m range, class 2) with 1 RJ45 connector</li> <li>■ For PowerSuite: 1 x 0.1 m cable with 2 RJ45 connectors</li> <li>■ For TwidoSoft: 1 x 0.1 m cable with 1 RJ45 connector and 1 mini DIN connector</li> <li>■ For ATV 38/58/58F drives: 1 RJ45/9-way male SUB-D adapter</li> </ul>	<b>VW3 A8 114</b>	0.155
<b>USB - Bluetooth® adapter for PC</b>	This adapter is required in the case of a PC that does not feature Bluetooth® technology. It is connected to a USB port on the PC. Range of 10 m (class 2).	<b>VW3 A8 115</b>	0.290

(1) Updates a version  $\geq$  V1.40 with the latest available version. For versions < V1.40, you should order the PowerSuite CD-ROM, VW3 A8 104.

(2) Please refer to the "Interfaces, I/O splitter boxes and power supplies" catalogue.

(3) Can also be used to communicate between a Twido PLC and the TwidoSoft software workshop.

**Compatibility of PowerSuite software workshop with the following devices (1)**

Connection	Controller	Starter-controller	Soft start/soft stop unit	Drives				Servo drives		
	TeSys T	TeSys U (2)	ATS 48	ATV 11	ATV 31	ATV 61	ATV 71	LXM 05A	LXM 05B	LXM 05C
Modbus	V2.5	V1.40	V1.30	V1.40	V2.0	V2.3	V2.2	V2.2	V2.4	V2.5
Modbus TCP (device equipped with Modbus TCP card)						V2.3	V2.2			
Modbus TCP via Modbus TCP/Modbus gateway			V1.50		V2.0	V2.3	V2.2	V2.2	V2.4	V2.5
Bluetooth®			V2.2		V2.2	V2.3	V2.2	V2.2	V2.4	V2.5

Compatible software versions  
 Incompatible software versions

**Hardware and software environments**

The PowerSuite software workshop can operate in the following PC environments and configurations:

- Microsoft Windows® XP SP1, SP2,
- Pentium III, 800 MHz, hard disk with 300 MB available, 128 MB RAM
- SVGA or higher definition monitor

(1) Minimum software version

(2) TeSys U starter-controller without communication module or with Modbus LUL C031, C032 or C033 communication module

# Starters, drives and communication

## Modbus TCP network

### Transparent Ready concept

#### Presentation

Introduced by Schneider Electric, the Transparent Ready concept enables transparent communication between control system devices, production and management. Network technologies and the associated new services are used to share and distribute data between sensors, PLCs, workstations and third-party devices in an increasingly efficient manner.

Web servers embedded in the network components and control system devices can be used to:

- Access configuration data transparently
- Perform remote diagnostics
- Incorporate simple human/machine interface functions

This concept is based on the Modbus TCP industrial standard which proposes a single network that meets most communication requirements from sensors/actuators through to production management systems.

Where a variety of communication systems are usually required, Transparent Ready standard technologies can result in significant cost savings in the areas of definition, installation, maintenance or training.

Transparent Ready is based on:

- Modbus TCP-based services meeting control system requirements in terms of functions, performance and quality of services
- Products including several ranges of PLC, distributed I/O, industrial terminals, variable speed drives, gateways and an increasing number of partner products
- The ConneXium range of cabling accessories: hubs, switches, cables adapted to the environment and to the requirements of industrial conditions.

Services	Network management	FDR (Faulty Device Replacement)		Web server		Messaging	I/O Scanning	MIB Transparent Ready
Applications	SNMP	DHCP	TFTP	FTP	HTTP	Modbus		
Transport	UDP			TCP				
Link	IP							
Physical	Ethernet 2							

Services supported by Altivar 61 and Altivar 71 drives

The Altistart 48 soft start/soft stop unit and the Altivar 31 variable speed drive are connected to the Modbus TCP network using a gateway TSX ETG 100 Ethernet/Modbus.

Altivar 61 and Altivar 71 variable speed drives are connected to the Modbus TCP network using a VW3 A3 310 communication card.

This card comes with a basic web server, which users can adapt completely according to the application (Java or FactoryCast development tool).

Characteristics		
<b>Structure</b>	Topology	Industrial local area network conforming to ANSI/IEEE 802.3 (4th edition 1993-07-08) Star network
	Transmission mode	Manchester baseband. Half-duplex or full-duplex
	Data rate	10/100 Mbps with automatic recognition
	Medium	STP double shielded twisted pair, impedance 100 W ± 15 W for 10 BASE-T or category 5 Ethernet cable, conforming to standard TIA/EIA-568A
	Length of network	100 m maximum between hub or switch and a station
<b>Type of device</b>	<b>ATS 48, ATV 31</b>	<b>ATV 61, ATV 71</b>
<b>Type of interface</b>	<b>TSX ETG 100</b>	<b>VW3 A3 310</b>
<b>Universal services</b>	SNMP	HTTP, BOOTP, DHCP, FTP, TFTP, SNMP
<b>Transparent Ready services</b>	Modbus Messaging	Modbus messaging, IO Scanning, FDR

## Universal services

### HTTP

HTTP, "Hypertext Transfer Protocol" (RFC 1945), is a protocol used to transmit web pages between a server and a browser. HTTP has been used on the Web since 1990.

*Web servers embedded in control system devices are at the heart of the Transparent Ready concept and provide easy access to devices anywhere in the world using a standard web browser such as Internet Explorer or Netscape Navigator.*

### BOOTP/DHCP

BOOTP/DHCP (RFC 1531) is used to supply (client) devices automatically with IP addresses and parameters. This avoids having to manage the addresses of each device individually by transferring their management to a server.

BOOTP identifies the client device by its Ethernet MAC address. This address is unique to each device and must be entered in the server each time the device is changed.

DHCP "Dynamic Host Configuration Protocol" identifies the client device by a name in plain language ("Device Name") which is maintained throughout the application: e.g. "Conveyor 23".

*Altivar 61 and Altivar 71 drives can be given a name ("Device Name") by the terminal or the PowerSuite software workshop.*

*The FDR ("Faulty Device Replacement") service uses the standard DHCP and TFTP protocols.*

### FTP/TFTP

FTP, "File Transfer Protocol" (RFCs 959, 2228 and 2640), and TFTP, "Trivial File Transfer Protocol" (RFC 1123), are used to exchange files with devices.

*Transparent Ready devices implement FTP for downloading firmware or custom web pages.*

*The FDR ("Faulty Device Replacement") service uses the standard DHCP and TFTP protocols.*

### SNMP

The Internet community has developed the SNMP standard, "Simple Network Management Protocol" (RFCs 1155, 1156 and 1157), to support the management of the various network components by means of a single system. The network management system can exchange data with SNMP agent devices. This function allows the manager to view the status of the network and devices, to modify their configuration and to return alarms in the event of a fault.

*Transparent Ready devices are compatible with SNMP and can be integrated naturally into a network administered via SNMP.*

# Starters, drives and communication

## Modbus TCP network

### Transparent Ready concept

#### Transparent Ready services

##### Modbus communication standard

Modbus, the industry communication standard since 1979, has been ported to Ethernet TCP/IP, the backbone of the Internet revolution, to create Modbus TCP, a totally open protocol on Ethernet. There is no need for any proprietary component, nor the purchase of a licence in order to develop a connection to Modbus TCP. This protocol can easily be ported to any device supporting a standard TCP/IP communication stack. The specifications can be obtained free of charge from the website: [www.modbus.org](http://www.modbus.org).

##### Modbus TCP, simple and open

The Modbus application layer is very simple and universally known. Thousands of manufacturers are already implementing this protocol. Many have already developed a Modbus TCP connection and numerous products are currently available. The simplicity of Modbus TCP enables any small field device, such as an I/O module, to communicate on Ethernet without the need for a powerful microprocessor or a large amount of internal memory.

##### Modbus TCP, high performance

Thanks to the simplicity of its protocol and the fast Ethernet throughput data rate of 100 Mbps, Modbus TCP achieves excellent performance. This means that this type of network can be used in realtime applications such as I/O Scanning.

#### I/O Scanning service

##### Schematic diagram

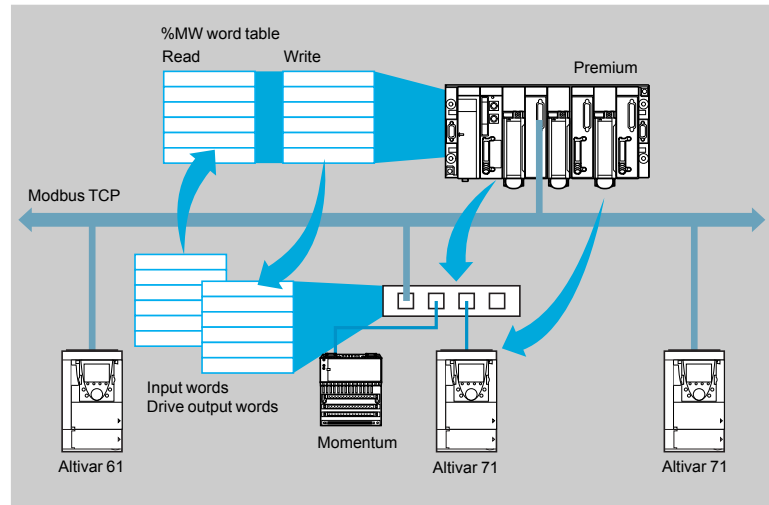

Altivar 61 and Altivar 71 drives accept the I/O Scanning service generated by:

- The following automation platforms:
  - Premium equipped with a TSX ETY 410/5101 module
  - Quantum
  - Momentum M1E
- A PC equipped with Modbus communication software with the I/O scanner function. This service is used to manage the exchange of remote I/O on the Ethernet network after simple configuration and without the need for special programming.

The drive I/O are scanned transparently by means of read/write requests according to the Modbus Master/Slave protocol on the TCP/IP profile.

The I/O Scanning service can be configured, activated or deactivated by:

- The PowerSuite software workshop
- The standard web server.

## Transparent Ready services (continued)

### Faulty Device Replacement (FDR) service

The FDR service uses standard DHCP and TFTP technologies with the aim of simplifying the maintenance of Ethernet devices. It is used to replace a faulty device with a new product, ensuring its detection, reconfiguration and automatic restarting by the system, without the need for any tricky manual intervention.

The main steps are:

- A device using the FDR service becomes faulty
- A similar device is taken out of the maintenance reserve base, preconfigured with the "Device\_name" of the faulty device, then reinstalled on the network.
- The FDR server (which can be a Quantum or Premium PLC Ethernet module) detects the new arrival, configures it with its IP address and transfers all its configuration parameters to it.
- The substituted device checks that the parameters are fully compatible with its own characteristics, then switches to operational mode.

## Web server

The Ethernet card in Altivar 61 and Altivar 71 drives incorporates a standard web server, in English. The functions provided by this web server require no special configuration or programming of the PC supporting the web browser. Using a password, two levels of access to the web server can be defined: read-only or modification.

The standard web server provides access to the following functions:

- Altivar Viewer
- Data Editor
- Ethernet Statistics
- Security
- Etc.

The standard web server can be adapted or replaced by a customized web server depending on the requirements of the application and downloaded via FTP. Knowledge of the HTTP protocol and Java technology are required to be able to create or modify a web server.

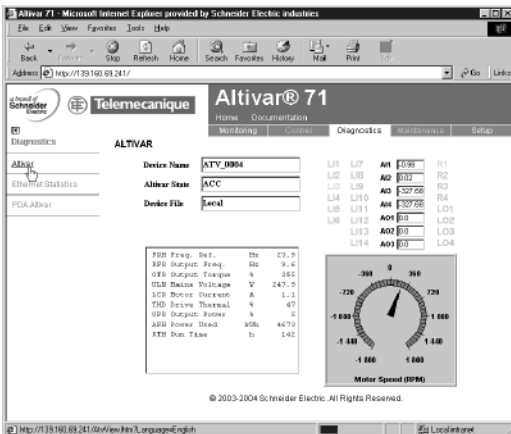

Altivar Viewer

## Connections

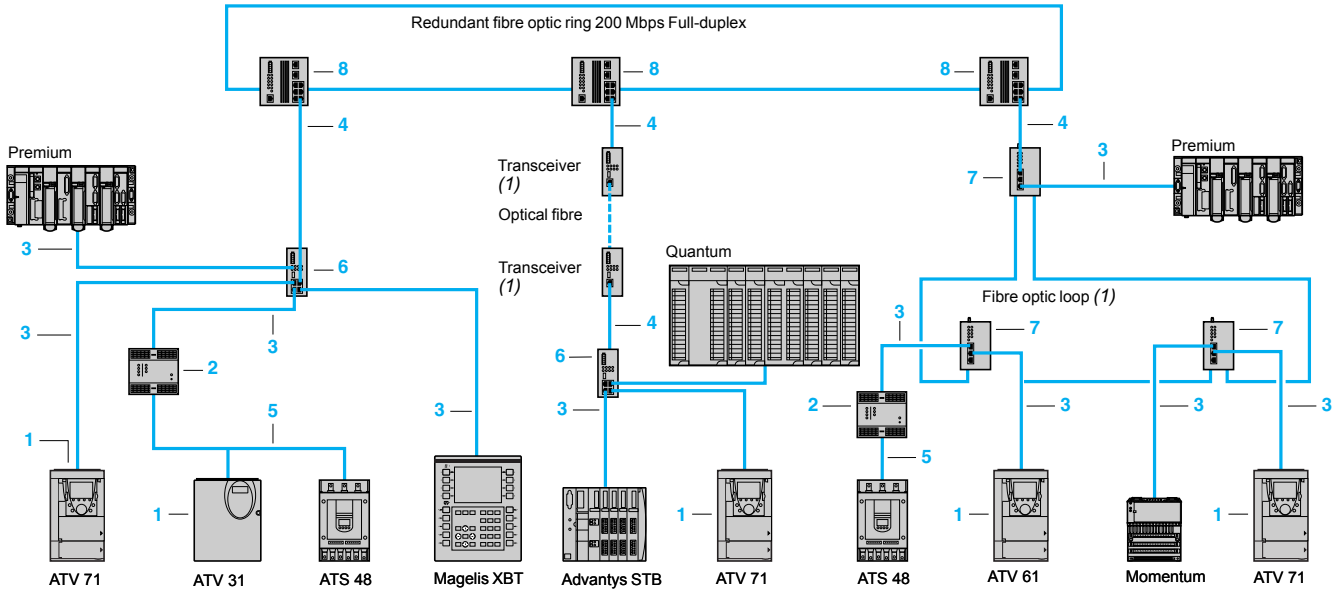

## Modbus TCP network connection elements (1)

Communication interfaces						
Description	Use	Item No.	Reference	Weight	kg	
<b>Communication card equipped with an RJ45</b> Modbus TCP 10/100 Mbps Class C20	Variable speed drives ATV 61, ATV 71	1	VW3 A3 310	0.300		
<b>Gateway/router Modbus Ethernet</b> Class B10	ATS 48 soft start/soft stop units ATV 31 variable speed drives	2	TSX ETG 100	-		
<b>Configuration kit</b>	Used to configure the gateway via the Ethernet or RS 232 port. Consists of an RJ45/9-way SUB-D adapter and a CAT5 crossover cable, length 3 m	-	TCS EAK 0100	-		
<b>PoE power supply</b> (conforming to IEEE 802.3af)	Used to supply the gateway via Ethernet CAT5 cable. Power supply connected via daisy-chain connection. Includes mains cable (Australia, Europe, UK and USA)	-	TCS EAQ 0100	-		
ConneXium cordsets						
Description	Use		Item No.	Length m	Reference (2)	Weight kg
	From	To				
<b>Straight shielded twisted pair cordsets</b> equipped with 2 RJ45 connectors	ATV 61 or	Hubs	3	2	490 NTW 000 02	-
	ATV 71	499 N●H 1●● ●0,		5	490 NTW 000 05	-
	(+ VW3 A3 310 communication card)	switches		12	490 NTW 000 12	-
	or any other equipment terminal	499 N●S ●●● 0●,		40	490 NTW 000 40	-
		TCS ESM083F2●●●	80	490 NTW 000 80	-	
<b>Crossed shielded twisted pair cordsets</b> equipped with 2 RJ45 connectors	Hubs	Hubs	4	5	490 NTW 000 05	-
	499 NEH 1●● ●0,	499 NEH 1●● ●0,		15	490 NTC 000 15	-
	switches	switches		40	490 NTC 000 40	-
	499 N●S 251 02,	499 N●S 251 02,		80	490 NTC 000 80	-
	TCS ESM083F2C●0,	TCS ESM083F2C●0,				
	transceivers (1)	transceivers (1)				
<b>Cordset for Modbus serial link</b> equipped with one RJ45 connector and one stripped end	ATS 48, ATV 31	Gateway Modbus/ Ethernet TSX ETG 100	5	3	VW3 A8 306 D30	-

(1) To order other Modbus TCP network connection elements, please refer to the "Ethernet TCP/IP, Transparent Ready" catalogue.  
 (2) Cable conforming to EIA/TIA-568 category 5 and IEC 1180/EN 50 173, class D. For UL and CSA 22.1 approved cables, add the letter U at the end of the reference. Example: 490 NTW 000 02 becomes 490 NTW 000 02U.



# Starters, drives and communication

Modbus TCP network  
Transparent Ready concept



499 NEH 141 00



499 NES 251 00



499 NMS 251 02

## Modbus TCP network connection elements (1) (continued)

### ConneXium Hubs

Description	Number of ports		Item No.	Reference	Weight kg
	Copper cable	Optical fibre			
<b>Hub - 10 Mbps twisted pair</b> 10BASE-T ports for copper cable, shielded RJ45 connectors	4	–	6	499 NEH 104 10	0.530
<b>Hub - 100 Mbps twisted pair</b> 100BASE-TX ports for copper cable, shielded RJ45 connectors	4	–	6	499 NEH 141 00	0.240
<b>Hub - 10 Mbps twisted pair and multimode optical fibre</b> 10BASE-T ports for copper cable, shielded RJ45 connectors 10BASE-FL ports for optical fibre, ST connectors (BFOC)	3	2	7	499 NOH 105 10	0.900

### ConneXium Switches

Description	Number of ports		Item No.	Managed	Reference	Weight kg
	Copper cable	Optical fibre				
<b>Optimized switch, twisted pair</b> 10BASE-T/100BASE-TX copper ports for copper cable, shielded RJ45 connectors	5	–	–	no	499 NES 251 00	0.190
<b>Switches, twisted pair</b> 10BASE-T/100BASE-TX ports for copper cable, shielded RJ45 connectors	8	–	–	no	499 NES 181 00	0.230
	8	–	–	yes	TCS ESM083F23F0	–
<b>Switches, twisted pair and multimode optical fibre</b> 10BASE-T/100BASE-TX ports for copper cable, shielded RJ45 connectors. 100BASE-FX ports for optical fibre, SC connectors	4	1	–	no	499 NMS 251 01	0.330
	3	2	8	no	499 NMS 251 02	0.335
	6	2	8	yes	TCS ESM083F2CU0	–
<b>Switches, twisted pair and single-mode optical fibre</b> 10BASE-T/100BASE-TX ports, for copper cable, shielded RJ45 connectors. 100BASE-FX ports, for optical fibre, SC connectors	4	1	–	no	499 NSS 251 01	0.330
	3	2	8	no	499 NSS 251 02	0.335
	6	2	8	yes	TCS ESM083F2CS0	–

(1) To order other Modbus TCP network connection elements, please refer to the "Ethernet TCP/IP, Transparent Ready" catalogue.



# Starters, drives and communication

## Communication via Fipio bus

### Presentation

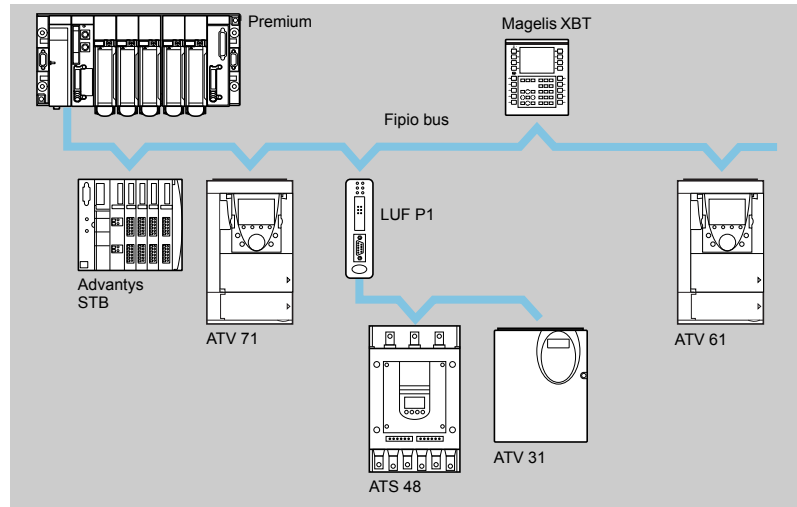

The Fipio fieldbus is a standard means of communication between control system components, and conforms to the World FIP standard.

A Premium PLC (bus manager) can control 127 devices (agents) over a maximum distance of 15 km.

The Fipio bus manager is integrated in the PLC processor.

The Altistart 48 soft start/soft stop unit and the Altivar 31 variable speed drive can be connected to the Fipio bus via an LUF P1 Fipio/Modbus gateway.

Altivar 61 and Altivar 71 drives can be connected to the Fipio bus via a communication card VW3 A3 311.

The following devices can also be connected to the Fipio bus:

- TSX Micro (2) or Premium Agent function (1) PLCs
- The CCX 17 operator panel (2)
- The Magelis XBT-F terminal with graphic screen (3)
- The Magelis iPC industrial PC (3)
- Advantys STB IP 20 distributed I/O (4)
- Discrete, analog or application-specific Momentum distributed I/O (5)
- Discrete or analog (IP 20) TBX distributed I/O (1)
- TBX discrete (IP 65) or TSX E●F (IP67) dust and damp proof distributed I/O (1)
- The TBX SAP 10 Fipio/AS-Interface gateway (1)
- The LUF P1 Fipio/Modbus gateway
- APC terminal
- Partner products in the Collaborative Automation programme

(1) Please consult our "Automation Platform Modicon Premium – Unity & PL7 software" specialist catalogue.

(2) Please consult our "Automation platform Modicon TSX Micro – PL7 software" specialist catalogue".

(3) Please consult our "Human-Machine interfaces" specialist catalogue.

(4) Please consult our "Distributed I/O Advantys STB" specialist catalogue.

(5) Please consult our "Modicon Momentum Automation platform" specialist catalogue.

# Starters, drives and communication

## Communication via Fipio bus

Characteristics			
<b>Structure</b>	Topology	Industrial bus conforming to the World FIP standard Subscribers linked via daisy-chain or tap junctions	
	Access method	Producer/consumer principle Bus management by a fixed arbitrator (bus manager)	
	Transmission mode	Baseband physical layer on shielded twisted pair, according to standard NF C 46-604	
	Data rate	1 Mbps	
	Medium	Shielded twisted pair 150 Ω Optical fibre 62.5/125 with the use of electrical/fibre optic repeaters	
	Number of subscribers	32 maximum per segment 1 manager + 127 agents maximum over all segments The number of Fipio agents is limited by the memory capacity of Premium processors (62 Altivar drives maximum) (1)	
	Number of segments	Unlimited in tree or star architectures Limited to 5 cascaded segments The link between 2 subscribers may cross 4 electrical or electrical/fibre optic repeaters maximum	
	Length of bus	15,000 m maximum 1,000 m maximum without repeater for an electrical segment 5,000 m maximum for 5 electrical segments 3,000 m maximum for 1 fibre optic segment	
<b>Type of device</b>	<b>ATS 48, ATV 31</b>	<b>ATV 61, ATV 71</b>	
<b>Type of interface</b>	<b>LUF P1</b>	<b>VW3 A3 311</b>	
<b>Profile</b>	FED C 32P	FED C 32	
<b>Control and adjustment</b>	26 configurable words	8 configurable words (communication scanner)	
<b>Monitoring</b>	26 configurable words	8 configurable words (communication scanner)	
<b>Configuration and adjustment</b>	1 indexed word Read/write access to all functions by the PLC application program		

(1) Please consult our "Automation Platform Modicon Premium – Unity & PL7 software" specialist catalogue.

## Fipio wiring system

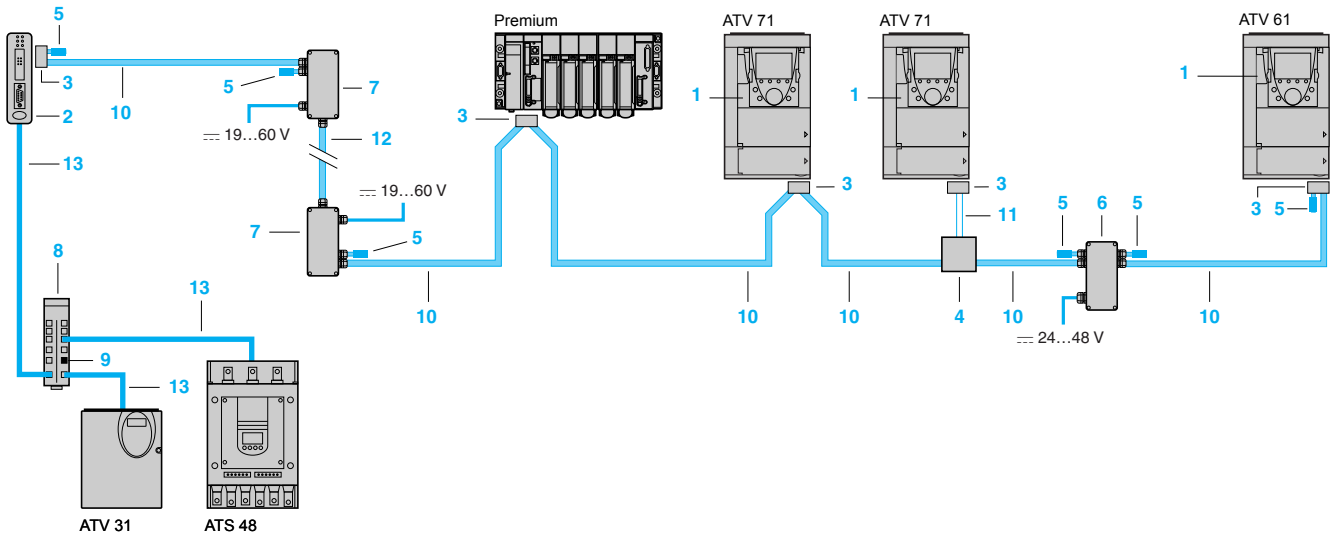

## Elements for connecting the Fipio bus and a Premium PLC (1)

### Cards and gateway

Description	Used for	No.	Reference	Weight kg
<b>Standard Fipio card</b> The card is equipped with a 9-way male SUB-D connector which can take a TSX FP ACC12 connector with a TSX FP CA●00 trunk cable or TSX FP CC●00 drop cable. This card should be used for new installations. It is also used to replace an ATV 58 or ATV 58F equipped with a VW3 A58 311 card by an ATV 71.	ATV 61 ATV 71	1	VW3 A3 311	0.300
<b>Substitution Fipio card</b> The card is equipped with a 9-way male SUB-D connector which can take a TSX FP ACC12 connector with a TSX FP CA●00 trunk cable or TSX FP CC●00 drop cable. This Fipio communication card is reserved for replacing an ATV 58 or ATV 58F equipped with a VW3 A58 301 card by an ATV 71.	ATV 71	1	VW3 A3 301	0.300
<b>Fipio/Modbus gateway</b> The gateway is equipped with: <ul style="list-style-type: none"> <li>■ 1 Fipio 9-way male SUB-D connector which can take a TSX FP ACC12 connector for use with a TSX FP CA●00 trunk cable or TSX FP CC●00 drop cable</li> <li>■ 1 RJ45 connector for Modbus for connection with the VW3 A8 306 R●● cable.</li> </ul> Fit an external 24 V $\ddot{}$ power supply, 100 mA minimum, to be ordered separately (2).	ATS 48 ATV 31	2	LUF P1	0.240



LUF P1

(1) To order other elements for connection to the Fipio bus, please consult our "Automation platform Modicon Premium – Unity & PL7 software" specialist catalogue.

(2) Please consult our "Power supplies, splitter blocks and interfaces" specialist catalogue.

# Starters, drives and communication

## Communication via Fipio bus

### Elements for connecting the Fipio bus and a Premium PLC (continued) (1)

#### Accessories

Description	Use	No.	Unit reference	Weight kg
<b>Female connector for device with 9-way female SUB-D connector</b> (polycarbonate, IP 20)	Connection via daisy-chain or tap junctions. For ATV 61, ATV 71, gateway LUF P1 and Premium PLC	3	TSX FP ACC12	0.040
<b>Tap junction</b> (polycarbonate, IP 20)	Trunk cable tap link	4	TSX FP ACC14	0.120
<b>Fipio line terminators</b> (sold in lots of 2)	Connector, tap junction and repeater	5	TSX FP ACC7	0.020
<b>Electrical repeater</b> (IP 65) Power supply 24...48 V $\overline{\text{---}}$ , 150 mA (2)	Increases the length of the bus while enabling connection of 2 segments of 1000 m maximum	6	TSX FP ACC6	0.520
<b>Electrical/fibre optic repeater</b> (IP 65) Power supply 19...60 V $\overline{\text{---}}$ , 210 mA (2)	Used for connection (via a patch panel) of an electrical segment (1000 m max.) and a fibre optic segment (3000 m max.)	7	TSX FP ACC8M	0.620
<b>Modbus splitter block</b> equipped with 10 RJ45 connectors and 1 screw terminal	Used to connect an ATV 31, ATS 48 on the LUP P1 gateway	8	LU9 GC3	0.500
<b>Modbus line terminators (3)</b>	LU9 GC3 Modbus splitter block	9	VW3 A8 306 RC	0.010
<b>FIP wiring test tool</b>	Used to test each section of a network segment	–	TSX FP ACC9	0.050

#### Connecting cables (1)

Description	Use		No.	Length m	Reference	Weight kg
	From	To				
<b>Trunk cables</b> 8 mm, 1 shielded twisted pair 150 $\Omega$ . In standard atmosphere (4) and inside buildings	Connector TSX FP ACC12,	Connector TSX FP ACC12,	10	100	TSX FP CA100	5.680
	junction box TSX FP ACC14,	junction box TSX FP ACC14,		200	TSX FP CA200	10.920
	repeaters TSX FP ACC6, ACC8M	repeater TSX FP ACC6		500	TSX FP CA500	30.000
<b>Trunk cables</b> 9.5 mm, 1 shielded twisted pair 150 $\Omega$ . In harsh environments (5), outside buildings or in mobile installations (6)	Connector TSX FP ACC12,	Connector TSX FP ACC12,	10	100	TSX FP CR100	7.680
	junction box TSX FP ACC14,	junction box TSX FP ACC14,		200	TSX FP CR200	14.920
	repeaters TSX FP ACC6, ACC8M	repeater TSX FP ACC6		500	TSX FP CR500	40.000
<b>Drop cables</b> 8 mm, 2 shielded twisted pairs 150 $\Omega$ . In standard atmosphere (4) and inside buildings	Connector TSX FP ACC12	Junction box TSX FP ACC14	11	100	TSX FP CC100	5.680
				200	TSX FP CC200	10.920
				500	TSX FP CC500	30.000
<b>Fibre optic jumper</b> Double optical fibre 62.5/125	Repeater TSX FP ACC8M	Patch panel	12	2	TSX FP JF020	0.550
<b>Cables for Modbus bus</b> 2 RJ45 connectors	LUF P1 gateway,	LU9 GC3	13	0.3	VW3 A8 306 R03	0.025
	ATS 48,	Modbus		1	VW3 A8 306 R10	0.060
	ATV 31	splitter block		3	VW3 A8 306 R30	0.130

#### Documentation

The manuals and quick reference guides for starters and variable speed drives, as well as the user manuals for communication gateways, are available on the web site: [www.telemecanique.com](http://www.telemecanique.com).

(1) To order other elements for connection to the Fipio bus, please consult our "Automation platform Modicon Premium – Unity & PL7 software" specialist catalogue.

(2) Please consult our "Power supplies, splitter blocks and interfaces" specialist catalogue.

(3) Sold in lots of 2.

(4) Standard environment:

- no particular environmental constraints
- operating temperature between +5°C and +60°C
- fixed installation

(5) Harsh environment:

- withstand to hydrocarbons, industrial oils, detergents, solder splashes
- relative humidity up to 100%
- saline atmosphere
- significant temperature variations
- operating temperature between -10°C and +70°C

(6) Mobile installation: cables in accordance with standard VDE 472 part 603/H:

- use on a cable-carrier chain with bending radius 75 mm minimum
- use on a gantry, provided that operating conditions such as acceleration, speed, length, etc, are adhered to: please consult your Regional Sales Office
- use not permitted on robots or multi-axis applications.

### Presentation

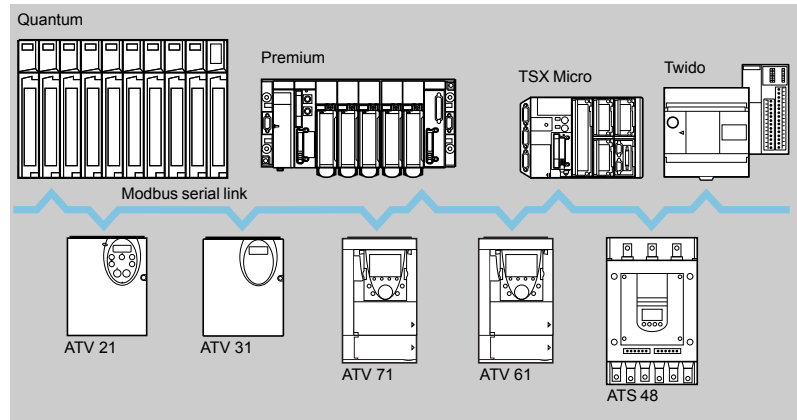

Modbus is a master/slave protocol.

Two exchange mechanisms are possible:

- Request/response: The request from the master is addressed to a given slave. The master then waits for the response from the slave which has been interrogated.
- Broadcasting: The master broadcasts a request to all the slave stations on the serial link, which execute the command without transmitting a response.

The Altistart 48 soft start/soft stop units and the Altivar 21, Altivar 31, Altivar 61 and Altivar 71 variable speed drives have the Modbus protocol integrated as standard.

The Altistart 48 soft start/soft stop unit and the Altivar 21 and Altivar 31 variable speed drives are connected to the Modbus serial link via their terminal ports.

The Altivar 61 and Altivar 71 variable speed drives have 2 integrated communication ports:

- A terminal port for connecting the graphic display terminal or an industrial HMI terminal (Magelis type)
- A Modbus serial link port

As an option, they can also be equipped with a VW3A3 303 Modbus/Uni-Telway communication card which offers additional characteristics (4-wire RS 485, ASCII mode, etc.).

### Characteristics

Type of device		ATS 48	ATV 21	ATV 31	ATV 61, ATV 71			
Type de connection		Terminal port				Modbus serial link port	Communication card	
Structure	Connector	RJ45	RJ45	RJ45	RJ45	RJ45	9-way female SUB-D	
	Topology	Serial link						
	Physical interface	2-wire RS 485					2-wire or 4-wire RS 485	
	Access method	Master/slave						
	Transmission mode	RTU					RTU or ASCII	
	Data rate	38.4 Kbps	–	–	–	–	•	–
		19.2 or 9.6 Kbps	•	•	•	•	•	•
		4.8 Kbps	•	–	•	–	•	•
	Medium	Double shielded twisted pair						
	Number of subscribers	18, 27 or 31 slaves, depending on polarization (1)						
	Type of polarization	4.7 kΩ pull-down resistors	No pull-down				Configurable. No pull-down or 4.7 kΩ pull-down resistors	
	Length of serial link	1000 or 1300 m excluding tap links, depending on polarization (1)						
	Tap link	3 or 20 m maximum, depending on polarization (1)						

(1) See the configuration table on page 299.

### Configuration on the basis of polarization

The specification of the physical layer provided by standard RS 485 is incomplete. Various polarization diagrams can therefore be applied depending on the environment in which the equipment is to be used.

The Modbus standard specifies the polarization exactly (1).

		Master	
		With or without polarization 4.7 kΩ	With polarization 470 Ω
Slave	Without polarization	Configuration not recommended.	Modbus type configuration 31 slaves. Length of serial link: 1300 m Tap link: 3 m maximum RC line terminators (R = 120 Ω, C = 1 nF)
	With polarization 4.7 kΩ	Uni-Telway type configuration 27 slaves Length of serial link: 1000 m Tap link: 20 m maximum RC line terminators (R = 120 Ω, C = 1 nF)	Mixed configuration 18 slaves Length of serial link: 1000 m Tap link: 20 m maximum RC line terminators (R = 120 Ω, C = 1 nF)

### Connection elements for RJ45 wiring system

Card				
Description	Used with	Reference	Weight	kg
<b>Communication card</b> equipped with a 9-way female SUB-D connector	ATV 61, ATV 71	<b>VW3 A3 303</b>		0.300

Accessories				
Description	No.	Unit reference	Weight	kg
<b>Modbus splitter block</b> 10 RJ45 connectors and 1 screw terminal block	1	<b>LU9 GC3</b>		0.500
<b>Modbus T-junction boxes</b>	With integrated cable (0.3 m)	2	<b>VW3 A8 306 TF03</b>	0,190
	With integrated cable (1 m)	2	<b>VW3 A8 306 TF10</b>	0,210
<b>Line terminators</b> for RJ45 connector (3)	R = 120 Ω, C = 1 nF	3	<b>VW3 A8 306 RC</b>	0,010
	R = 150 Ω	3	<b>VW3 A8 306 R</b>	0,010

Cables						
Description	Use		No.	Length m	Reference	Weight kg
	From	To				
<b>Cables for Modbus serial link</b> 2 RJ45 connectors	ATS 48, ATV 21, ATV 31, ATV 61, ATV 71 (terminal ports or Modbus serial link ports)	Modbus splitter block LU9 GC3	4	0.3	<b>VW3 A8 306 R03</b>	0.025
		Modbus T-junction box VW3 A8 306 TF●●		1	<b>VW3 A8 306 R10</b>	0.060
		Modbus splitter block LU9 GC3		3	<b>VW3 A8 306 R30</b>	0.130
<b>Cables for Modbus serial link</b> One 9-way male SUB-D connector 1 RJ45 connector	ATV 61, ATV 71 (+ communication card VW3 A3 303)	Modbus splitter block LU9 GC3	4	1	<b>VW3 A58 306 R10</b>	0.080
		Modbus splitter block LU9 GC3		3	<b>VW3 A58 306 R30</b>	0.150
<b>Double shielded twisted pair cables</b>	Modbus splitter block LU9 GC3 (screw terminals)	Modbus splitter block LU9 GC3 (screw terminals)	5	100	<b>TSX CSA 100</b>	5.680
				200	<b>TSX CSA 200</b>	10.920
				500	<b>TSX CSA 500</b>	30.000

(1) Standard defined in 2002, available on the website: [www.modbus.org](http://www.modbus.org).

(2) The cable for connecting the PLC and the splitter block depends on the type of PLC; please consult our "Automation platform Modicon Premium – Unity & PL7 software", "Automation platform Modicon Quantum", "Automation platform Modicon TSX Micro – PL7 software" and "Automation and relay functions" specialist catalogues.

(3) Sold in lots of 2.

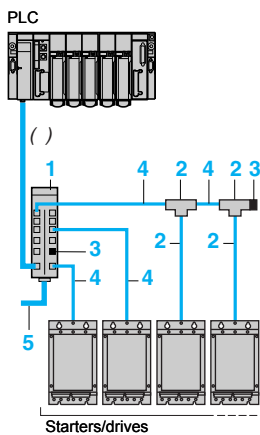

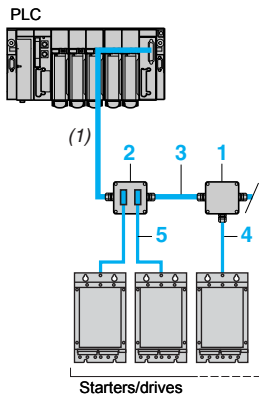

TSX SCA 50



TSX SCA 62

## Connection elements using tap junctions

### Accessories

Description	No.	Reference	Weight kg
<b>Tap junction</b> 3 screw terminals, RC line terminator	1	TSX SCA 50	0.520
<b>Subscriber socket</b> Two 15-way female SUB-D connectors and 2 screw terminals, RC line terminator	2	TSX SCA 62	0.570

### Cables

Description	Use		No.	Length m	Reference	Weight kg
	From	To				
<b>Double shielded twisted pair cables</b>	Tap junction	Tap junction	3	100	TSX CSA 100	5.680
	TSX SCA 50, subscriber socket	TSX SCA 50, subscriber socket		200		
	TSX SCA 62	TSX SCA 62		500		
<b>Cable for Modbus serial link</b> 1 RJ45 connector and one stripped end	ATS 48, ATV 21, ATV 31, ATV 61, ATV 71 (terminal ports or Modbus serial link ports)	Tap junction TSX SCA 50	4	3	VW3 A8 306 D30	0.150
<b>Cable for Modbus serial link</b> 1 RJ45 connector and one 15-way male SUB-D connector	ATS 48, ATV 21, ATV 31, ATV 61, ATV 71 (terminal ports or Modbus serial link ports)	Subscriber socket TSX SCA 62	5	3	VW3 A8 306	0.150
<b>Cable for Uni-Telway and Modbus serial link</b> 2 male SUB-D connectors, 9 and 15-way	ATV 61, ATV 71 (+ communication card VW3 A3 303)	Subscriber socket TSX SCA 62	5	3	VW3 A8 306 2	0.150

(1) The cable for connecting the PLC and the splitter block depends on the type of PLC; please consult our "Automation platform Modicon Premium - Unity & PL7 software", "Automation platform Modicon Quantum", "Automation platform Modicon TSX Micro - PL7 software" and "Automation and relay functions" specialist catalogues.

# Starters, drives and communication

## Communication via Modbus serial link

### Connection elements using screw terminals

#### Accessories

Description		Sold in lots of	Reference unit	Weight kg
Line terminators for screw terminals	R = 120 $\Omega$ , C = 1 nF	2	VW3 A8 306 DRC	0.200
	R = 150 $\Omega$	2	VW3 A8 306 DR	0.200

#### Cable

Description	Use		Length m	Reference	Weight kg
	From	To			
Cable for Modbus 1 RJ45 connector and one stripped end	ATS 48, ATV 21, ATV 31, ATV 61, ATV 71 (terminal ports or Modbus serial link ports)	Standard screw terminal, tap junction TSX SCA 50	3	VW3 A8 306 D30	0.150

#### Documentation

The manuals and quick reference guides for starters and variable speed drives, as well as the user manuals for communication gateways, are available on the website: [www.telemecanique.com](http://www.telemecanique.com).



# Starters, drives and communication

## Communication via Modbus Plus network

### Presentation

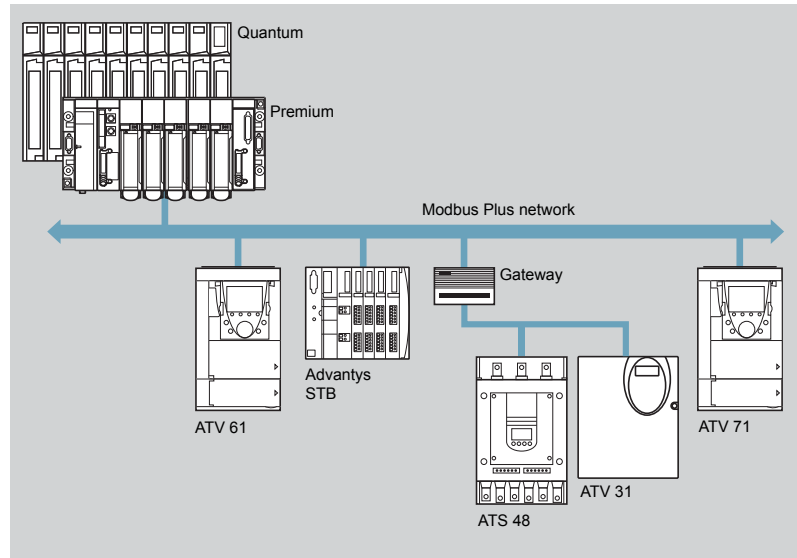

The Modbus Plus network is a high-performance industrial local area network which can be used to meet the needs of client/server type extended architectures, combining a high data rate (1 Mbps), simple, low-cost transmission media and numerous messaging services.

The Altistart 48 soft start/soft stop unit and the Altivar 31 variable speed drive can be connected to the Modbus Plus network via an NW BM85000 gateway which has four RS 232 serial ports.

The Altivar 61 and Altivar 71 variable speed drives are connected to the Modbus Plus network via communication card VW3 A3 302.

### Communication services

The main data exchange services between subscribers connected to the network are:

- The “Modbus messaging” service according to Modbus protocol
- The “Global Data” service: each subscriber makes available 32 words for each of the 63 other network subscribers
- The “Peer Cop” dialogue service: point-to-point transaction of 32 receive or transmit words

The “Global Data” and “Peer Cop” services are restricted to a Modbus Plus network with a maximum of 64 subscribers.

Altivar 61 and Altivar 71 drives are accessed by simple configuration in the PLC using “Peer Cop” and “Global Data” services.

These services enable rapid exchange of the main drive parameters:

- The “Peer Cop” service for controlling and adjusting the drive
- The “Global data” service for monitoring the drive

Other parameters, which are used less frequently, can be accessed by the Modbus messaging service.

Characteristics		
<b>Structure</b>	Topology	Network
	Physical interface	RS 485
	Access method	Token network
	Transmission mode	HDLC synchronous
	Data rate	1 Mbps
	Medium	Shielded twisted pair 120 Ω Optical fibre
	Number of subscribers per network	32, without repeater 64, with one or more repeaters
	Number of networks	4, separated by a maximum of 3 bridges
	Length of network	450 m maximum without repeater 1800 m maximum with 3 electrical repeaters 3000 m between 2 fibre optic repeaters
	<b>Services</b>	Modbus messaging
"Global Data"		4096-byte shared database Cyclic exchange of 32 broadcast words Limited to one network This service does not cross bridges
"Peer Cop" dialogue		Point-to-point or broadcast message Limited to one network This service does not cross bridges
<b>Type of device</b>	<b>ATS 48, ATV 31</b>	<b>ATV 61, ATV 71</b>
<b>Type of interface</b>	<b>NW BM85000</b>	<b>VW3 A3 302</b>
<b>Control</b>	"Modbus messaging"	"Peer Cop" 8 configurable words maximum (communication scanner)
<b>Monitoring</b>	"Modbus messaging"	"Global Data" 8 configurable words maximum (communication scanner)
<b>Configuration and adjustment</b>	"Modbus messaging"	"Modbus messaging" Read/write access to all drive parameters

## Modbus Plus wiring system

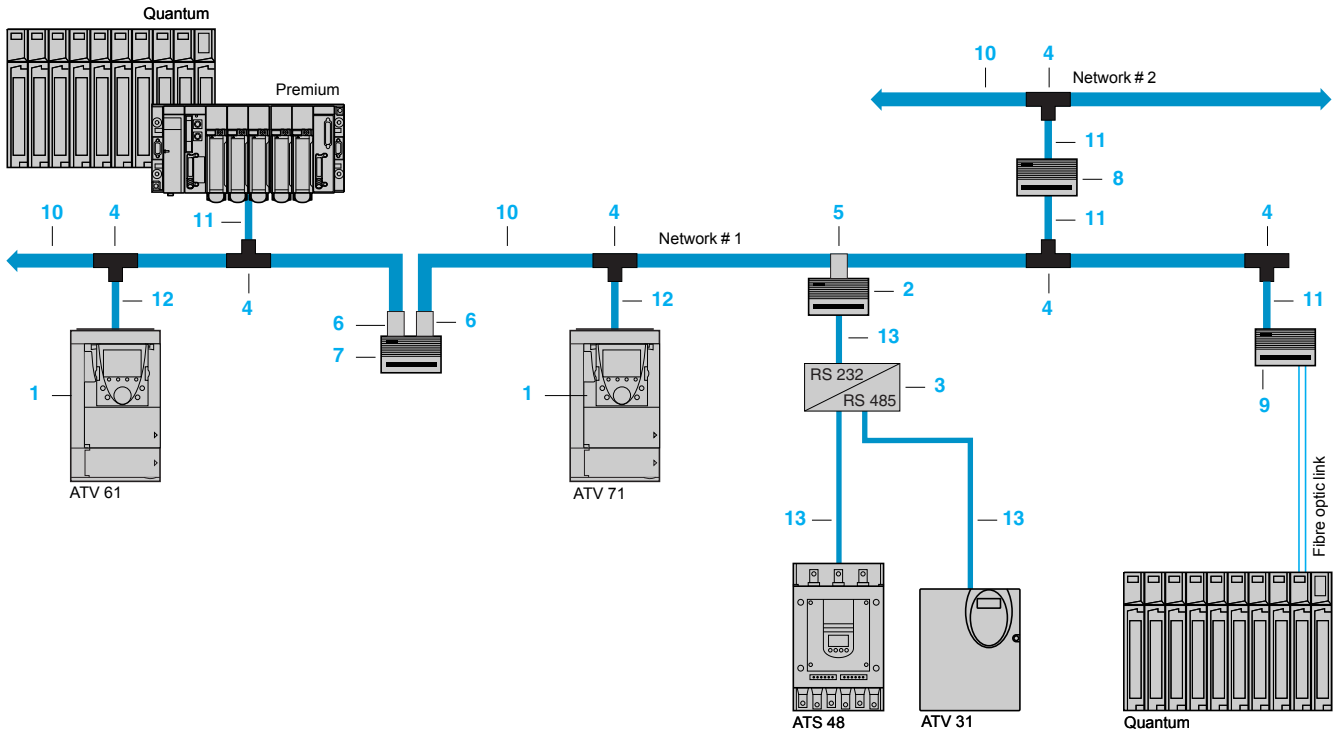

## Modbus Plus network connection elements (1)

Cards and gateways				
Description	Used with	No.	Reference	Weight kg
<b>Communication cards</b> equipped with one 9-way female SUB-D connector	ATV 61, ATV 71	1	VW3 A3 302	0.300
<b>Modbus Plus/Modbus gateway</b> 4 RS 232 ports power supply 115...220 V ~	ATS 48, ATV 31	2	NW BM85000	3.158
<b>RS 232/RS 485 interface</b> power supply 24 V ~, 20 mA (2)	ATS 48, ATV 31	3	XGS Z24	0.105
Connection accessories				
Description	Use	No.	Reference	Weight kg
<b>Modbus Plus tap</b> (IP 20)	For connecting via a tap junction	4	990 NAD 230 00	0.230
<b>Modbus Plus in-line connector</b>	Gateway, bridge and repeater	5	AS MBKT 085	0.035
<b>Connector with Modbus Plus terminator</b> (sold in lots of 2)	Bridge and repeater	6	AS MBKT 185	0.260
<b>Modbus Plus electrical repeater</b>	Extension beyond 450 m or up to 64 subscribers	7	NW RR85 001	2.677
<b>Modbus Plus bridge with 4 ports</b>	Connection of 4 networks maximum	8	NW BP85 002	2.813
<b>Line/station fibre-optic repeater</b>	-	9	490 NRP 254 00	2.856
<b>Point-to-point fibre-optic repeater</b>	Used to connect an electrical segment to the fibre-optic segment (3000 m maximum)	-	NW NRP 253 00	2.863
<b>Wiring tool</b>	Inserting trunk and drop cables in a 990 NAD 230 00 tap	-	043 509 383	3.000

(1) To order other connection elements, please consult our "Automation platform Modicon Premium – Unity & PL7 software" and "Automation platform Modicon Quantum" specialist catalogues.  
 (2) Please consult our "Power supplies, splitter blocks and interfaces" specialist catalogue.

# Starters, drives and communication

## Communication via Modbus Plus network

Modbus Plus network connection elements (continued) (1)							
Cables							
Description	Use		No.	Length m	Reference	Weight kg	
	From	To					
<b>Trunk cables for Modbus Plus</b>	Modbus Plus tap 990 NAD 230 00	Modbus Plus tap 990 NAD 230 00,	<b>10</b>	30.5	<b>490 NAA 271 01</b>	1.833	
		Modbus Plus in-line connector		152.5		<b>490 NAA 271 02</b>	10.135
		AS MBKT 085, Modbus Plus connector with terminators		305		<b>490 NAA 271 03</b>	18.940
		AS MBKT 185		457		<b>490 NAA 271 04</b>	30.000
				1525		<b>490 NAA 271 06</b>	112.950
<b>Drop cables</b> One 9-way male SUB-D connector and one stripped end	Premium, Quantum PLCs, Modbus Plus bridge with 4 ports NW BP85 002, line/station fibre optic repeater 490 NRP 253 00	Modbus Plus tap 990 NAD 230 00	<b>11</b>	2.4	<b>990 NAD 211 10</b>	0.169	
				6		<b>990 NAD 211 30</b>	0.459
		ATV 61, ATV 71 (+ communication card VW3 A3 302)		<b>12</b>		2.4	<b>990 NAD 219 10</b>
	6	<b>990 NAD 219 30</b>	0.465				
<b>Cable for Modbus</b> 1 RJ45 connector and one stripped end	ATS 48, ATV 31, Modbus Plus/ Modbus gateway NW BM85000	RS 232-RS 485 interface	<b>13</b>	3	<b>VW3 A8 306 D30</b>	0.115	

(1) To order other connection elements, please consult our "Automation platform Modicon Premium – Unity & PL7 software" and "Automation platform Modicon Quantum" specialist catalogues.

## Presentation

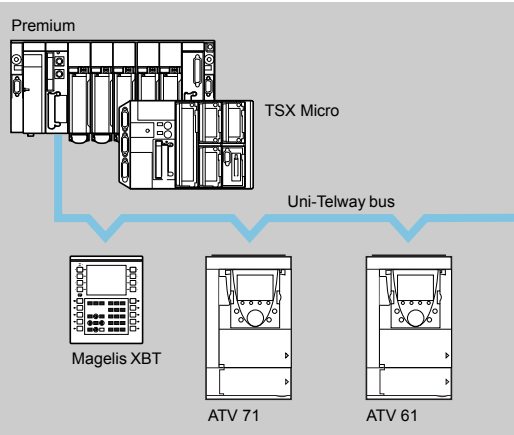

The Uni-Telway bus is a standard means of communication between control system components (PLCs, HMI terminals, supervisors, variable speed drives, numerical controllers, etc).

The Uni-Telway bus requires a master station (Premium, TSX Micro PLCs) which manages the allocation of bus access rights to the various connected slave stations (HMI terminals, variable speed drives, etc). The slave stations can communicate with one another without programming the master station.

An industrial HMI terminal (Magelis type) can be connected directly to the bus and can be used to adjust drives without developing applications specific to the PLC.

The Altivar 61 and Altivar 71 variable speed drives can be connected to the Uni-Telway bus via a communication card VW3 A3 303.

## Characteristics

Structure	Topology	Bus
	Physical interface	RS 485 isolated
	Link	Multidrop
	Access method	Master/slave type
	Transmission mode	Asynchronous transmission in baseband
	Data rate	4.8...19.2 Kbps
	Medium	Double shielded twisted pair
	Number of stations	28 maximum
	Length of bus	1000 m maximum excluding tap links
	Tap links	20 m maximum
Services	UNI-TE	Request/response of up to 240 bytes (1) initiated by any connected station. Unsolicited point-to-point data of up to 240 bytes (1) without confirmation report, initiated by any connected station. Broadcast messages of up to 240 bytes (1) initiated by the master station.
	Other functions	Transparent communication, via the master station, with any X-WAY architecture. Diagnostics, debugging, adjustment, programming of PLCs.
	Security	Check character on each frame, acknowledgement and, if required, repetition of messages ensure security of transmission.
	Monitoring	The bus status table, transmission error counters and station status can be accessed on each station.

## Uni-Telway bus wiring system

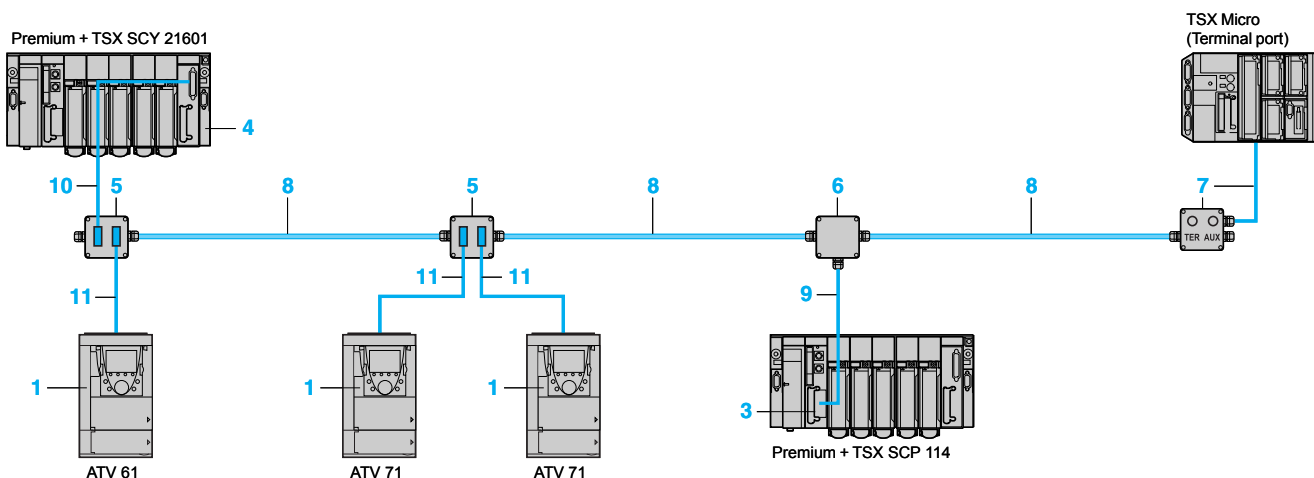

(1) Limited to 128 bytes with the Premium and TSX Micro PLC terminal port.

# Starters, drives and communication

## Communication via Uni-Telway bus

### Uni-Telway bus connection elements (1)

#### Cards, kit and module

Description	Used with	No.	Protocol	Reference	Weight kg
<b>Communication card</b> card equipped with a 9-way female SUB-D connector	ATV 61 ATV 71	1	Uni-Telway, Modbus	VW3 A3 303	0.300
<b>RS 485 type III PCMCIA card</b> (compatible with RS 422) 1.2...19.2 Kbps	Premium, Atrium, TSX Micro PLCs, or TSX SCY 21601 module	3	Uni-Telway, Modbus, character mode	TSX SCP 114	0.105
<b>Communication module</b>	Premium or Atrium PLC	4	Uni-Telway, Modbus, character mode	TSX SCY 21601	0.360

#### Connection accessories

Description	Use	No.	Reference	Weight kg
<b>Subscriber socket</b> Two 15-way female SUB-D connectors and 2 screw terminals	2-channel junction box, trunk cable extension and line terminator	5	TSX SCA 62	0.570
<b>Tap junction</b> 3 screw terminals	Junction box, trunk cable extension and line terminator	6	TSX SCA 50	0.520
<b>Terminal port connection box</b> with integrated cable, length 1 m	Connection of a TSX Micro or Premium PLC via the PLC terminal port and line terminator	7	TSX P ACC 01	0.690

#### Cables

Description	Use		No.	Length m	Reference	Weight kg
	From	To				
<b>Uni-Telway double shielded twisted pair cables</b>	Junction box TSX SCA 50, subscriber socket	Subscriber socket	8	100	TSX CSA 100	5.680
	subscriber socket TSX SCA 62, terminal port connection box	junction box TSX SCA 50, terminal port connection box		200	TSX CSA 200	10.920
	TSX SCA 62, terminal port connection box	TSX SCA 50, terminal port connection box		500	TSX CSA 500	30.000
<b>Cables for isolated RS 485 tap link</b>	Card TSX SCP 114	Junction box TSX SCA 50	9	3	TSX SCP CU 4030	0.160
		Subscriber socket TSX SCA 62	9	3	TSX SCP CU 4530	0.180
	Integrated channel (channel 0) of TSX SCY 21601 module	Junction box TSX SCA 50	10	3	TSX SCP CU 6030	0.180
		Subscriber socket TSX SCA 62	10	3	TSX SCY CU 6530	0.200
<b>Cable for Uni-Telway or Modbus bus</b> 2 male SUB-D connectors 9 and 15-way	ATV 61, ATV 71 (+ communication card VW3 A3 303)	Subscriber socket TSX SCA 62	11	3	VW3 A8 306 2	0.150

(1) To order other elements for connection to the Fipio bus, please consult our "Automation platform Modicon Premium – Unity & PL7 software" and "Automation platform Modicon TSX Micro – PL7 software" specialist catalogues.



TSX SCA 62



TSX SCA 50



TSX P ACC 01

### Presentation

Communication gateways LUF P allow connection between the Modbus serial link and Fipio, Profibus DP or DeviceNet field buses.

After configuration, these gateways manage information which can be accessed by the Modbus serial link and make this information available for read/write functions (command, monitoring, configuration and adjustment) on the field buses.

An LUF P communication gateway consists of a box which can be clipped onto a 35 mm omega rail, allowing connection of up to 8 Slaves connected on the Modbus serial link.

### Example of architecture

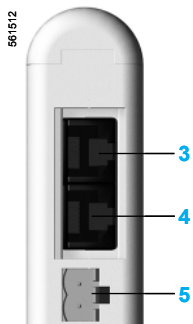
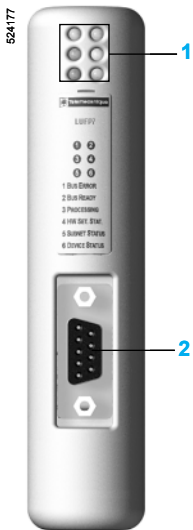
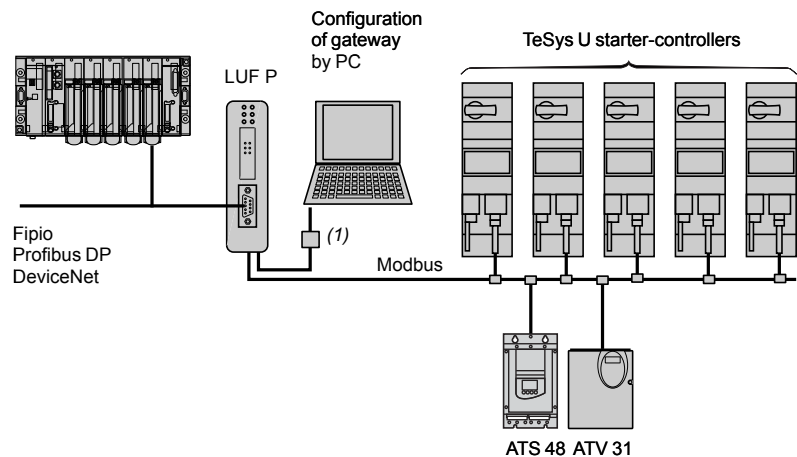

### Description

#### Front panel of the product

- 1 LED indicating :
  - communication status of the Modbus serial links,
  - gateway status,
  - communication status of the Fipio, Profibus DP or DeviceNet bus.
- 2 Connectors for connection to Fipio, Profibus DP or DeviceNet buses.

#### Underside of product

- 3 RJ45 connector for connection of the Modbus serial link
- 4 RJ45 connector for link to a PC
- 5  $\text{---}$  24 V power supply

### Software set-up

For the Fipio bus, software set-up of the gateway is performed using either PL7 Micro/Junior/Pro software or ABC Configurator software.

For the Profibus DP and DeviceNet buses, software set-up is performed using ABC Configurator.

This software is included in the TeSys U user's manual.

(1) Connection kit for PowerSuite software workshop (see page 286).

### Characteristics

Bus type		Fipio	Profibus DP	DeviceNet
<b>Environment</b>	Conforming to IEC 60664	Degree of pollution: 2		
<b>Ambient air temperature</b>	Around the device	°C + 5...+ 50		
<b>Degree of protection</b>		IP 20		
<b>Electromagnetic compatibility</b>	Emission	Conforming to IEC 50081-2: 1993		
	Immunity	Conforming to IEC 61000-6-2: 1999		
<b>Number of Modbus slaves which can be connected</b>		≤ 8		
<b>Connection</b>	Modbus	By RJ45 connector conforming to Schneider Electric RS485 standard		
	To a PC	By RJ45 connector, with PowerSuite connection kit		
	Field bus	By SUB D9 female connector	By SUB D9 female connector	By 5-way removable screw connector
<b>Supply</b>		<b>V</b> External supply, $\pm 24 \pm 10 \%$		
<b>Consumption</b>	Max.	<b>mA</b> 280		
	Typical	<b>mA</b> 100		
<b>Indication/diagnostics</b>		By LED on front panel		
<b>Services</b>	Profile	FED C32 or FED C32P	–	–
	Command	26 configurable words (1)	122 configurable words	256 configurable words
	Monitoring	26 configurable words (1)	122 configurable words	256 configurable words
	Configuration and adjustment	By gateway mini messaging facility (PKW)		

### References

Description	For use with	With bus/serial link	Reference	Weight kg
<b>Communication gateways</b>	TeSys U starter-controllers, Altistart 48, Altivar 31	Fipio/Modbus	LUF P1	0.245
		Profibus DP/Modbus	LUF P7	0.245
		DeviceNet/Modbus	LUF P9	0.245

### Connection accessories

Description	For use with	Length m	Connectors	Reference	Weight kg
<b>Connection cables</b>	Modbus	3	1 RJ45 type connector and one end with stripped wires	VW3 A8 306 D30	0.150
		0.3	2 RJ45 type connectors	VW3 A8 306 R03	0.050
		1	2 RJ45 type connectors	VW3 A8 306 R10	0.050
		3	2 RJ45 type connectors	VW3 A8 306 R30	0.150
<b>Connectors</b>	Fipio	–	1 SUB-D 9 male connector	TSX FP ACC12	0.040
		–	1 SUB-D 9 male connector	490 NAD 911 04	–
		–	1 SUB-D 9 male connector	490 NAD 911 03	–

822831



TSX FP ACC 12

822713



490 NAD 911 03

### Documentation

Description	Medium	Language	Reference	Weight kg
<b>User's manual for TeSys U range (2)</b>	CD-Rom	Multilingual: English, French, German, Italian, Spanish	LU9 CD1	0.022

### Dimensions

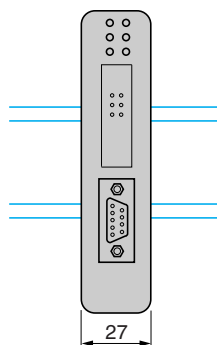
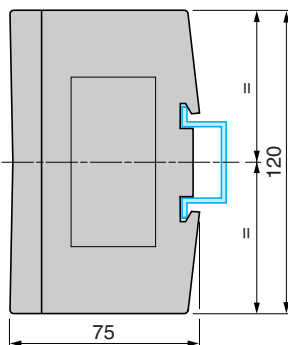

- (1) If the gateway is configured using PL7 and not ABC Configurator, the I/O capacity is limited to a total of 26 words.
- (2) This CD-Rom contains user's manuals for AS-Interface and Modbus communication modules, multifunction control units and gateways, as well as for the gateway programming software, ABC Configurator.





# Product reference index

043 509 383	304	TSX CAN CA 50	125 and 135	VW3 AE 073●	57 and 91	VW3 A58 306 R●●	299	VW3 CAN KCDF 180T	135
490 NAA 271 0●	305			VW3 AE 08●●	56 and 57	VW3 A5850●	153		
490 NAD 911 0●	309	TSX CAN CB ●00	125 and 135	VW3 AE 081●	89 and 91	VW3 A7 10●	137	X	
490 NRP 254 00	304			VW3 AE 090●	90	VW3 A7 70●	140 and 141	XGS Z24	286 and 304
490 NT● 000 ●●	292	TSX CAN CB 50	125 and 135	VW3 AE 091●	90 and 91	VW3 A7 706	140		
499 NEH ●●● ●●	293			VW3 AE 092●	91	VW3 A7 708	140		
499 NES ●●● 00	293	TSX CAN CD ●00	125 and 135	VW3 AE 100●	57	VW3 A7 709	140		
499 NMS 251 0●	293			VW3 AE 1003	54	VW3 A7 71●	140		
499 NOH 105 10	293	TSX CAN CD 50	125 and 135	VW3 AE 1●0●	53 and 86	VW3 A7 716	140 and 141		
499 NSS 251 0●	293			VW3 AE 2●0●	53 and 86	VW3 A7 717	140 and 141		
990 NAD 21● ●●	305	TSX CAN KCDF 180T	125	VW3 A1 10●	108	VW3 A7 718	140 and 141		
990 NAD 230 00	304	TSX CSA ●●●	299, 300, and 307	VW3 A1 102	109	VW3 A7 80●	141		
<b>A</b>				VW3 A1 104 R●●	108 and 109	VW3 A7 81●	141		
AS MBKT ●●●	304	TSX AndG 100	292	VW3 A3 101	26	VW3 A7E 10●	91		
ATV 61E5075N4	76	TSX FP ACC●●	297	VW3 A3 20●	113	VW3 A7E 101	54 and 87		
ATV 61E5D●●N4	76	TSX FP CA●00	297	VW3 A3 30●	134	VW3 A7E 102	87		
ATV 61E5U●●N4	76	TSX FP CC●00	297	VW3 A3 301	296	VW3 A8 10●	286		
ATV 61EXS5C●●Y	84	TSX FP CR●00	297	VW3 A3 302	134 and 304	VW3 A8 106	125 and 286		
ATV 61HC●●Y	23	TSX FP JF020	297	VW3 A3 303	134 and 307	VW3 A8 11●	286		
ATV 61HD●●Y	23	TSX P ACC 01	307	VW3 A3 31●	134	VW3 A8 306	300		
ATV 61HU●●Y	23	TSX SCA ●●	300 and 307	VW3 A3 310	134 and 292	VW3 A8 306 2	300 and 307		
ATV 61EXC2C●●●●	50 and 51	TSX SCP 114	307	VW3 A3 311	134 and 296	VW3 A8 306 D30	292 300, 301, 305, and 309		
ATV 61EXC2D●●●●	50	TSX SCP CU ●●●●	307	VW3 A3 40●	111	VW3 A8 306 DR	301		
ATV 61EXC5C●●●●	50 and 51	TSX SCY 21601	307	VW3 A3 50●	117	VW3 A8 306 R	135 and 299		
ATV 61EXC5D●●●●	50	TSX SCY CU 6530	307	VW3 A3 501	125	VW3 A8 306 R●●	109, 135, 297, 299 and 309		
ATV 61EXS5C●●●●	84	<b>V</b>		VW3 A3E ●●●	52 and 85				
ATV 61EXS5D●●●●	84	VW3 AE 01●●	54 and 87	VW3 A4 40●	111 and 162	VW3 A8 306 RC	109, 135, 297 and 299		
ATV 61H075M3	20	VW3 AE 010●	54, 57, 87 and 91	VW3 A4 41●	162				
ATV 61H075●●N4	21	VW3 AE 020●	54 and 87	VW3 A4 50●	149	VW3 A8 306 TF●●	109, 135 and 299		
ATV 61HC●●N4	21	VW3 AE 021●	54 and 87	VW3 A4 51●	149				
ATV 61HC●●Y	23	VW3 AE 030●	55	VW3 A4 55●	153 and 154				
ATV 61HD●●M3X	20	VW3 AE 04●●	55, 57, 88 and 91	VW3 A4 558	154				
ATV 61HD●●N4	21	VW3 AE 0411	55 and 88	VW3 A4 56●	154				
ATV 61HD●●Y	23	VW3 AE 05●●	55, 57, 88 and 91	VW3 A4 568	153 and 154				
ATV 61HU●●M3	20	VW3 AE 060●	55, 57 and 91	VW3 A4 569	153 and 154				
ATV 61HU●●N4	21	VW3 AE 061●	88	VW3 A4 57●	154				
ATV 61HU●●Y	23	VW3 AE 062●	57 and 88	VW3 A4 60●	156				
ATV 61W075N4	22	VW3 AE 063●	91	VW3 A4 62●	157				
ATV 61W075N4C	22	VW3 AE 064●	55	VW3 A4 63●	157				
ATV 61WD●●N4	22	VW3 AE 065●	55	VW3 A4 64●	158				
ATV 61WD●●N4C	22	VW3 AE 066●	55 and 88	VW3 A4 65●	158				
ATV 61WU●●N4	22	VW3 AE 067●	88	VW3 A4 66●	159				
ATV 61WU●●N4C	22	VW3 AE 07●●	56	VW3 A4 67●	159				
<b>L</b>		VW3 AE 071●	56 and 89	VW3 A5 10●	166 and 167				
LU9 CD1	309	VW3 AE 072●	57 and 89	VW3 A5 2●●	169				
LU9 GC3	109, 135, 297 and 299								
LUF P1	296 and 309								
<b>N</b>									
NW BM85000	304								
NW BP85 002	304								
NW NRP 253 00	304								
NW RR85 001	304								
<b>T</b>									
TCS EA● 0100	292								
TCS ESM083F2●●●	293								
TSX CAN CA ●00	125 and 135								

# The efficiency of Telemecanique branded *solutions*

Used in combination, Telemecanique products provide quality solutions, meeting all your **Automation** and **Control** applications requirements.



## Simple machines

**Altistart 01**: 0.37 to 75 kW

**Altivar 11**: 0.18 to 2.2 kW

**Altivar 31**: 0.18 to 15 kW



## Complex, high power machines

**Altivar 71**: 0.37 to 630 kW



## Pumping and ventilation machines

**Altistart 48**: 4 to 1 200 kW

**Altivar 11...347**: 0.18 to 2.2 kW

**Altivar 21**: 0.75 to 75 kW

**Altivar 61**: 0.75 to 800 kW



## A worldwide presence

### Constantly available

■ More than 5 000 points of sale in 190 countries.

■ You can be sure to find the range of products that are right for you and which complies fully with the standards in the country where they are used.

### Technical assistance wherever you are

■ Our technicians are at your disposal to assist you in finding the optimum solution for your particular needs.

■ Schneider Electric provides you with all necessary technical assistance, throughout the world.

[www.telemecanique.com](http://www.telemecanique.com)

## Schneider Electric Industries SAS

Head Office  
89, bd Franklin Roosevelt  
92506 Rueil-Malmaison Cedex  
France

[www.schneider-electric.com](http://www.schneider-electric.com)

Due to evolution of standards and equipment, the characteristics indicated in texts and images of this document do not constitute a commitment on our part without confirmation.

Design: Schneider Electric

Photos: Schneider Electric

Printed by:

*Simply Smart!*

