

Variable speed drives Altivar 12

For 3-phase motors from 0,18 to 4 kW

Catalogue

October **2009**



Variable speed drives

Altivar 12

- **Brochure** page 2
- **Selection guide** page 6
- **Presentation** page 8
- **Characteristics** page 10
- **References** page 14
- **Dimensions and mounting recommendations** page 18
- **Schemes** page 22
- **Motor starters** page 24
- **Functions** page 26

Designing technology that frees you from technical tasks

Small + **Intuitive**
Reliable + **High-performance**

With the Altivar 12, you get greater reliability and simplicity of operation and save even more time for all your applications.

- The smallest drive with integrated EMC for compact machines
- Ever more intuitive and user-friendly programming and menus
- Can be configured in complete safety with the power off, even in its packaging
- A design that can withstand even the harshest environments
- Quick and simple to set up
- With no compromise on quality, and components designed to last 10 years

Collaborative design

We surveyed our customers and users to determine their needs. The result is the innovative Altivar 12.



Make the most of your energy

Combining efficiency with intelligence

The Altivar 12 is particularly suitable for use in applications involving simple industrial machines or certain consumer machines. Its compact size, high performance and discreet appearance make it particularly attractive for use in the following sectors:

- The food industry (ventilation of catering kitchens, bagging machines, bakers' kneading machines, greenhouses, etc.)
- Small handling applications (car washes, conveyors, etc.)
- The medical and health sector (medical beds, fitness machines)
- Machines with a single-phase socket (wood-working machines, surface polishing and cleaning machines, swimming pool or irrigation pumps, hydromassage bathtubs, etc.)
- New markets (solar applications, etc.)
- Simple mechanical applications (2-speed motors, DC motors, mechanical drives, etc.)



A design focussed on integration

- Upgrade your machines and make them more competitive: with its advanced functions (integrated PID, multi-speed) the Altivar 12 increases your productivity
- Communicate easily with all the other parts of your machine via the integrated universal Modbus serial link
- Reduce the depth of your equipment: the baseplate mounted version dissipates heat into the machine frame



+ **Small**

The small format and advanced functions of the Altivar 12 mean that it can easily replace any existing drive in its category.

+ **Economical**

- Design: Save time by using the SoMove software workshop
- Commissioning: Quicker configuration with the power off download function
- Wiring and mounting: Quicker and easier installation with integrated Modbus communication

Choose peace of mind

The Altivar 12 integrates as standard all the technologies that will make you forget it is there. Its design and choice of components make the Altivar 12 an extremely efficient, reliable and durable drive.

No compromise on quality

- Ever higher performance for your motors assured by:
 - The factory settings, which provide a high quality drive from the very first time the power is turned on
 - The integration of Standard (U/f), Performance (sensorless flux vector control, or SVC) and Pump/Fan (quadratic profile Ktr) control profiles
 - High dynamic performance on acceleration as well as on braking
- Excellent speed regulation on machine load surges
- Reduced noise and maintenance:
 - No fan on models up to 0.75 kW at 240 V
 - Cassette type fan, operates automatically on detection of specific temperature setting
- Designed for easy fitting and wiring of the drive:
 - A single tool
 - Power terminals not tightened, ready for wiring
 - Easy access angles
- Numerous, easy to identify markings
- Fast detection and protection against the motor current peaks associated with certain applications (motor switching, catching on the fly, etc.)
- Perfect integration of single-phase 240 V model into the electrical network thanks to its built-in EMC filter



The fan, which is the only wearing part, can be changed without the need for any tool.



Practical, recyclable packaging. You can configure your product in its packaging without breaking the guarantee seal.

Ecological

- An average of 30% energy savings (with the Pump/Fan control profile) for the majority of applications
- Less cardboard to be recycled - only one box is used for bulk orders



Communicate intuitively with all your applications

The Altivar 12 is immediately operational. It is configured using the notched wheel or from the SoMove software workshop. The file that is generated can be downloaded to the product even while it is still in its packaging, using the Multi-Loader console. You save commissioning time so that you can spend more time doing your job.



Fast

With the Multi-Loader console you can configure 10 drives in their packaging in less than 5 minutes, with no power supply!

Save time on programming

- A navigation button for easy menu access: you can set the parameters of your application with just a few clicks
- A three-level tree structure
- Reference Mode: In local operation (On/Off buttons) and for speed adjustment and display
- Monitoring Mode: For displaying parameters
- Configuration Mode: For configuring your applications and settings

Save time on commissioning

- The drive can be configured before it is received (by the distributor), during storage (by the storekeeper) or during fitting before the electrical enclosure is powered up for the first time
- No adjustment is required and there is a quick start guide for immediate setup
- Work in the language of your choice with the SoMove software workshop that can be downloaded free of charge from www.schneider-electric.com
- Select the functions you need from the menu
- Bluetooth option for PC for greater ease of use

Save time on wiring

- Easy access to all the wiring and adjustment functions on the front panel via a sealable hinged door
- Integrated EMC filter in 240 V single-phase versions
- No need to remove the terminal cover to wire the power section
- Only one screwdriver needed for wiring both the control and power sections
- Less wiring due to the integrated Modbus communication



Use SoMove to customise your menus and save time during operation (possible for up to 25 parameters)



Sturdy

- New generation long-life components (10-year service life under normal operating conditions)
- Cards are coated as standard and as resistance to disturbed power supplies has been increased to withstand harsh environments



Easy to identify

- All the identification markings on the product are on a hinged door on the front panel
- Easy identification of the connections





Versatile

The Altivar 12 range is designed for 120 to 240 V power supplies. For your productivity requirements in the most varied applications, see the complete Altivar range on our website: www.schneider-electric.com



Variable speed drives for asynchronous and synchronous motors

Type of machine		Simple machines	Pumps and fans (building HVAC)) (1)	
				
Power range for 50...60 Hz (kW) line supply		0.18...4	0.18...15	0.75...75
Single-phase 100...120 V (kW)		0.18...0.75	–	–
Single-phase 200...240 V (kW)		0.18...2.2	0.18...2.2	–
Three-phase 200...230 V (kW)		–	–	–
Three-phase 200...240 V (kW)		0.18...4	0.18...15	0.75...30
Three-phase 380...480 V (kW)		–	–	0.75...75
Three-phase 380...500 V (kW)		–	0.37...15	–
Three-phase 525...600 V (kW)		–	0.75...15	–
Three-phase 500...690 V (kW)		–	–	–
Drive	Output frequency	0.5...400 Hz	0.5...500 Hz	0.5...200 Hz
	Type of control	Asynchronous motor	Synchronous motor	–
Asynchronous motor		Standard (voltage/frequency) Performance (sensorless flux vector control) Pump/fan (K ⁿ quadratic ratio)	Standard (voltage/frequency) Performance (sensorless flux vector control) Energy saving ratio	Sensorless flux vector control Voltage/frequency ratio (2 points) Energy saving ratio
Synchronous motor		–	–	–
Transient overtorque		150...170% of the nominal motor torque	170...200% of the nominal motor torque	110% of the nominal motor torque
Functions				
Number of functions		40	50	50
Number of preset speeds		8	16	7
Number of I/O	Analog inputs	1	3	2
	Logic inputs	4	6	3
	Analog outputs	1	1	1
	Logic outputs	1	–	–
	Relay outputs	1	2	2
Communication	Embedded	Modbus	Modbus and CANopen	Modbus
	Available as an option	–	CANopen Daisy chain, DeviceNet, PROFIBUS DP, Modbus TCP, Fipio	LONWORKS, METASYS N2, APOGEE FLN, BACnet
Cards (available as an option)		–		
Standards and certifications		IEC/EN 61800-5-1, IEC/EN 61800-3 (environments 1 and 2, categories C1 to C3) CE, UL, CSA, C-Tick, NOM, GOST		
		EN 55011: Group 1, class A and class B with option card, CE, UL, CSA, C-Tick, NOM		
References		ATV 12	ATV 312	ATV 21
Pages		14	Consult our "Altivar 312 speed drives" catalogue	Consult our "Soft starters and variable speed drives" catalogue

(1) Heating Ventilation Air Conditioning

**Pumps and fans
(industrial)**



Complex machines



0.37...800
–
0.37...5.5
–
0.75...90
0.75...630
–
–
2.2...800

0.5...500 Hz across the entire range
0.5...1000 Hz up to 37 kW at 200...240 V ~ and 380...480 V ~
Sensorless flux vector control
Voltage/frequency ratio (2 or 5 points)
Energy saving ratio
Vector control without speed feedback
120...130% of the nominal motor torque for 60 seconds

> 100
8
2...4
6...20
1...3
0...8
2...4

Modbus and CANopen
Modbus TCP, Fipio, Modbus/Uni-Telway, Modbus Plus, EtherNet/IP, DeviceNet, PROFIBUS DP, PROFIBUS DP V1, INTERBUS S, CC-Link, LonWorks, METASYS N2, APOGEE FLN, BACnet

I/O extension cards, "Controller Inside" programmable card, multi-pump cards

IEC/EN 61800-5-1, IEC/EN 61800-3 (environments 1 and 2, C1 to C3), IEC/EN 61000-4-2/4-3/4-4/4-5/4-6/4-11, CE, UL, CSA, DNV, C-Tick, NOM, GOST

ATV 61

Consult our "Altivar 61 speed drives" catalogue and our "Soft starters and variable speed drives" catalogue

0.37...630
–
0.37...5.5
–
0.37...75
0.75...500
–
–
1.5...630

1...500 Hz across the entire range
1...1600 Hz up to 37 kW at 200...240 V ~ and 380...480 V ~
Flux vector control with or without sensor
Voltage/frequency ratio (2 or 5 points)
ENA System
Vector control with or without speed feedback
220% of the nominal motor torque for 2 seconds
170% for 60 seconds

> 150
16
2...4
6...20
1...3
0...8
2...4

Modbus TCP, Fipio, Modbus/Uni-Telway, Modbus Plus, EtherNet/IP, DeviceNet, PROFIBUS DP, PROFIBUS DP V1, INTERBUS S, CC-Link

Interface cards for incremental, resolver, SinCos, SinCos Hiperface®, EnDat® or SSI encoders, I/O extension cards, "Controller Inside" programmable card, overhead crane card

ATV 71

Consult our "Altivar 71 speed drives" catalogue and our "Soft starters and variable speed drives" catalogue



ATV 12 controlling an access barrier



ATV 12 controlling a mixer



ATV 12 controlling a pumping station



Presentation

The Altivar 12 drive is a frequency inverter for three-phase 200...240 V asynchronous motors rated from 0.18 kW to 4 kW.

The Altivar 12's ease of installation, based on the principle of Plug&Play, its compact size, its integrated functions and its alternative base plate version make it particularly suitable for applications involving simple industrial machines and certain consumer machines.

By taking account of the constraints governing installation and use at the product design stage, we have been able to offer a reliable, cost-effective solution to manufacturers of compact simple machines (OEMs) and installers.

Examples of solutions provided:

- Drive factory-configured for start-up without the need for any adjustment
- Multi-Loader configuration tool for loading a configuration onto the drive without taking it out of its packaging
- Labelled terminals to reduce wiring time; drive identification on the front panel
- Alternative delivery option of multiple units in a single special package (1). Like with the individually-shipped drives, it is possible to load a configuration into each drive without taking them out of the packaging.

Applications

Applications for simple industrial machines

- Handling (small conveyors, etc.)
- Packaging (small labelling machines, small bagging machines, etc.)
- Pumping applications (suction pumps, centrifugal pumps, circulating pumps, mono-pump and multi-pump stations, etc.)
- Machines equipped with a fan (air or smoke extraction, plastic film making machines, ovens, boilers, washing machines, etc.)

Applications for consumer machines

- Handling (access barriers, rotating advertising hoardings, etc.)
- Machines for health-related areas (medical beds, hydromassage equipment, running machines, etc.)
- Food and beverage industry machines (mills, kneading machines, mixers, etc.)

Other types of application

- Food and beverage industry (battery farming, greenhouses, etc.)
- Miscellaneous applications (mobile machines and small appliances equipped with a power socket, etc.)
- Applications which traditionally use other solutions:
 - 2-speed motor, DC motor, mechanical drive, etc.
 - Single-phase motor for pump and fan applications using mechanical control; the "Altivar 12 + three-phase motor" solution adapts the power to the requirements of the driving application, thus reducing energy consumption.

Functions

In addition to the functions usually available on this type of drive, the Altivar 12 drive also features the following:

- Switching between local control and control via the terminals
- Motor control profiles: standard, performance and pump/fan
- Frequency skip
- Preset speeds
- PID regulator
- S ramp, U ramp, ramp switching
- Freewheel stop, fast stop
- Jog operation
- Configuring the logic and analog I/O
- Underload and overload detection
- Viewing the state of the logic inputs on the drive display
- Configuring how the parameters are displayed
- Error log, etc.

(1) Depending on the model (see page 14)



Drive with heatsink
ATV 12H075M2



Drive on base plate
ATV 12P075M2

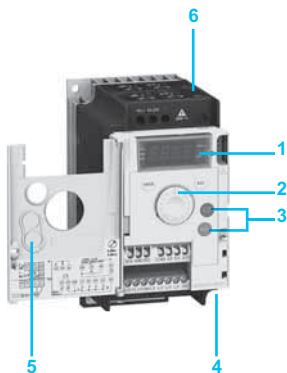

ATV 12H075M2 with door open
from front panel open



Multi-Loader
configuration tool



Remote terminal
with cover closed



Remote terminal with cover
open: RUN, FWD/REV and
STOP buttons accessible

An optimized offer

The Altivar 12 range of variable speed drives extends across a range of motor power ratings from 0.18 kW to 4 kW on three types of power supply: Two standard versions are available:

- Drive with heatsink for normal environments and fan-cooled enclosure:
 - 100...120 V single-phase, 0.18 kW to 0.75 kW (ATV 12H●●●F1)
 - 200...240 V single-phase, 0.18 kW to 2.2 kW (ATV 12H●●●M2)
 - 200...240 V three-phase, 0.18 kW to 4 kW (ATV 12H●●●M3)
- Drive on a base plate for mounting on the machine frame; the frame surface area should allow heat to dissipate:
 - 100...120 V single-phase, 0.18 kW to 0.37 kW (ATV 12H018F1, P037F1)
 - 200...240 V single-phase, 0.18 kW to 0.75 kW (ATV 12H018M2, P●●●M2)
 - 200...240 V three-phase, 0.18 kW to 4 kW (ATV 12H018M3, P●●●M3)

Note: The Altivar 12 drive output voltage is 200...240 V three-phase, regardless of the type of drive line supply.

The Altivar 12 drive integrates as standard the Modbus communication protocol, which can be accessed via the RJ45 connector located on the underside of the drive 4.

The entire range conforms to international standards IEC/EN 61800-5-1 and IEC/EN 61800-3, is UL, CSA, C-Tick, NOM, GOST certified and has been developed to meet the requirements of directives regarding the protection of the environment (RoHS, WEEE) as well as those of European Directives to obtain the CE mark.

Electromagnetic compatibility (EMC)

The integration of a level C1 EMC filter in ATV 12●●●●M2 drives and the handling of EMC simplify installation and make it very inexpensive to bring the device into conformity to obtain the CE mark.

This EMC filter can be disconnected via an internal switch 6.

ATV 12●●●●F1 and ATV 12●●●●M3 drives are designed without an EMC filter. Filters are available as an option and can be installed by the customer to reduce the level of emissions (see page 16).

External accessories and options

External accessories and options can be used with Altivar 12 drives:

- EMC conformity kits, plates for direct mounting on 35 mm rail, etc.
- Braking units combined with a braking resistor, motor chokes, additional EMC input filters, etc.

Dialogue and configuration tools

Human-Machine Interface (HMI)

The 4-digit display 1 can be used to display states and faults, access parameters and modify them via the navigation button 2.

The RUN and STOP buttons 3 can be made accessible on the front panel by removing the blanking plate 5 from the door; they must be configured in order to be active.

Simple Loader and Multi-Loader configuration tools

The Simple Loader tool enables one powered-up drive's configuration to be duplicated on another powered-up drive.

The Multi-Loader tool enables configurations from a PC or drive to be copied and duplicated on another drive; the drives do not need to be powered up.

SoMove setup software

The SoMove setup software can be used with the Altivar 12 drive for configuration, adjustment, debugging (using the Oscilloscope function) and maintenance, just as it can for all other Schneider Electric variable speed drives and starters. It can also be used to customize the integrated display terminal menus. It can be used with a direct connection or a Bluetooth® wireless connection.

Remote display terminal

The Altivar 12 drive can be connected to a remote display terminal, available as an option. This terminal can be mounted on an enclosure door with IP 54 or IP 65 degree of protection. The maximum operating temperature is 50°C. It provides access to the same functions as the Human-Machine interface.

Environmental characteristics

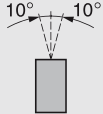
Conformity to standards		Altivar 12 drives have been developed to conform to the strictest international standards and the recommendations relating to electrical industrial control equipment (IEC, EN), in particular: IEC/EN 61800-5-1 (low voltage), IEC/EN 61800-3 (conducted and radiated EMC immunity and emissions).
EMC immunity		IEC/EN 61800-3, Environments 1 and 2 (EMC requirements and specific test methods) IEC/EN 61000-4-2 level 3 (electrostatic discharge immunity test) IEC/EN 61000-4-3 level 3 (radiated, radio-frequency, electromagnetic field immunity test) IEC/EN 61000-4-4 level 4 (electrical fast transient/burst immunity test) IEC/EN 61000-4-5 level 3 (surge immunity test) IEC/EN 61000-4-6 level 3 (immunity to conducted disturbances, induced by radio-frequency fields) IEC/EN 61000-4-11 (voltage dips, short interruptions and voltage variations immunity tests)
Conducted and radiated EMC emissions for drives	ATV 12●●●●F1 ATV 12H018M3 ATV 12●037M3...●U22M3	With additional EMC filter: ■ IEC/EN 61800-3, Environment 1 (public network) in restricted distribution: □ Category C1, at 2, 4, 8, 12 and 16 kHz for a shielded motor cable length ≤ 5 m □ Category C2, from 2 to 16 kHz for a shielded motor cable length ≤ 20 m ■ IEC/EN 61800-3, Environment 2 (industrial network): □ Category C3, from 2 to 16 kHz for a shielded motor cable length ≤ 20 m
	ATV 12●●●●M2	■ IEC/EN 61800-3, Environment 1 (public network) in restricted distribution: □ Category C1, at 2, 4, 8, 12 and 16 kHz for a shielded motor cable length ≤ 5 m □ Category C2: ATV 12H018M2...●075M2, from 2 to 12 kHz for a shielded motor cable length ≤ 5 m and at 2, 4, 16 kHz for a shielded motor cable length ≤ 10 m □ Category C2: ATV 12HU15M2...HU22M2, from 4 to 16 kHz for a shielded motor cable length ≤ 5 m and at 2, 4, 8, 12 and 16 kHz for a shielded motor cable length ≤ 10 m With additional EMC filter: ■ IEC/EN 61800-3, Environment 1 (public network) in restricted distribution: □ Category C1, at 2, 4, 8, 12 and 16 kHz for a shielded motor cable length ≤ 20 m □ Category C2, from 2 to 16 kHz for a shielded motor cable length ≤ 50 m ■ IEC/EN 61800-3, Environment 2 (industrial network): □ Category C3, from 2 to 16 kHz for a shielded motor cable length ≤ 50 m
CE marking		The drives are marked CE according to the European low voltage (2006/95/EC) and EMC (2004/108/EC) directives
Product certifications		UL, CSA, NOM, GOST and C-Tick
Degree of protection		IP 20
Vibration resistance	Drive not mounted on rail 	According to IEC/EN 60068-2-6: □ 1.5 mm peak from 3 to 13 Hz □ 1 gn from 13 to 200 Hz
Shock resistance		15 gn for 11 ms according to IEC/EN 60068-2-27
Maximum ambient pollution Definition of insulation		Degree 2 according to IEC/EN 61800-5-1
Environmental conditions Use		IEC 60721-3-3 classes 3C3 and 3S2
Relative humidity		% 5...95 non condensing, no dripping water, according to IEC 60068-2-3
Ambient air temperature around the device	Operation	ATV 12H018F1, H037F1 ATV 12H018M2...H075M2 ATV 12H018M3...H075M3 ATV 12P●●●●●
		ATV 12H075F1 ATV 12HU15M2, HU22M2 ATV 12HU15M3...HU40M3
	Storage	ATV 12●●●●●●
Maximum operating altitude	ATV 12●●●●●●	m 1000 without derating
	ATV 12●●●●F1 ATV 12●●●●M2	m Up to 2000 for single-phase networks and corner grounded distribution networks, with current derating of 1% per additional 100 m
	ATV 12●●●●M3	m Up to 3000 meters for three-phase networks, with current derating of 1% per additional 100 m
Operating position Maximum permanent angle in relation to the normal vertical mounting position		

(1) See the possible mounting types on page 21.

(2) See the derating curves in the User Manual, available on our website at "www.schneider-electric.com".

Drive characteristics		
Output frequency range	Hz	0.5...400
Configurable switching frequency	kHz	Nominal switching frequency: 4 kHz without derating in continuous operation Adjustable during operation from 2 to 16 kHz Above 4 kHz in continuous operation, apply derating to the nominal drive current of: <ul style="list-style-type: none"> ■ 10% for 8 kHz ■ 20% for 12 kHz ■ 30% for 16 kHz Above 4 kHz, the drive will reduce the switching frequency automatically in the event of excessive temperature rise. See the derating curves in the User Manual, available on our website at "www.schneider-electric.com".
Speed range		1...20
Transient overtorque		150...170% of the nominal torque depending on the drive rating and the type of motor
Braking torque		<ul style="list-style-type: none"> ■ Up to 70% of the nominal torque without resistor ■ Up to 150% of the nominal motor torque with braking unit (optional) at high inertia
Maximum transient current		150% of the nominal drive current for 60 seconds
Motor control profiles		<ul style="list-style-type: none"> ■ Standard profile (voltage/frequency ratio) ■ Performance profile (sensorless flux vector control) ■ Pump/fan profile (K_n² quadratic ratio)

Electrical power characteristics			
Power supply	Voltage	V	100 - 15% to 120 + 10% single-phase for ATV 12●●●●F1 200 - 15% to 240 + 10% single-phase for ATV 12●●●●M2 200 - 15% to 240 + 10% three-phase for ATV 12●●●●M3
	Frequency	Hz	50...60 ± 5%
	Isc (short-circuit current)	A	≤ 1000 (Isc at the connection point) for single-phase power supply ≤ 5000 (Isc at the connection point) for three-phase power supply
Drive supply and output voltages			Drive supply voltage
	ATV 12●●●●F1	V	100...120 single-phase
	ATV 12●●●●M2	V	200...240 single-phase
	ATV 12●●●●M3	V	200...240 three-phase
Maximum length of motor cable (including tap links)	Shielded cable	m	50
	Unshielded cable	m	100
Drive noise level	ATV 12H018F1, H037F1 ATV 12H018M2...H075M2 ATV 12H018M3...H075M3 ATV 12P●●●●●	dBA	0
	ATV 12H075F1 ATV 12HU15M2, HU22M2	dBA	45
	ATV 12HU15M3...HU40M3	dBA	50
Electrical isolation			Electrical isolation between power and control (inputs, outputs, power supplies)

Connection characteristics (drive terminals for the line supply, the motor output and the braking unit)			
Drive terminals		R/L1, S/L2/N, T/L3, U/T1, V/T2, W/T3, PA/+, PC/-	
Maximum wire size and tightening torque	ATV 12H018F1, H037F1 ATV 12H018M2...H075M2 ATV 12H018M3...H075M3 ATV 12P037F1 ATV 12P037M2...P075M2 ATV 12P037M3, P075M3		3.5 mm ² (AWG 12) 0.8 Nm
	ATV 12H075F1 ATV 12HU15M2, HU22M2 ATV 12HU15M3...HU40M3 ATV 12PU15M3...PU40M3		5.5 mm ² (AWG 10) 1.2 Nm

Electrical characteristics (control)

Available internal supplies		Protected against short-circuits and overloads: <ul style="list-style-type: none"> ■ One 5 V \pm supply (\pm 5%) for the reference potentiometer (2.2 to 10 kΩ), maximum data rate 10 mA ■ One 24 V \pm supply (-15%/+20%) for the control inputs, maximum data rate 100 mA
Analog input	AI1	1 software-configurable voltage or current analog input: <ul style="list-style-type: none"> ■ Voltage analog input: 0...5 V \pm (internal power supply only) or 0...10 V \pm, impedance 30 kΩ ■ Analog current input: X-Y mA by programming X and Y from 0...20 mA, impedance 250 Ω Sampling time: < 10 ms Resolution: 10 bits Accuracy: \pm 1% at 25°C Linearity: \pm 0.3% of the maximum scale value Factory setting: Input configured as voltage type
Analog output	AO1	1 software-configurable voltage or current analog output: <ul style="list-style-type: none"> ■ Analog voltage output: 0...10 V \pm, minimum load impedance 470 Ω ■ Analog current output: 0 to 20 mA, maximum load impedance 800 Ω Update time: < 10 ms Resolution: 8 bits Accuracy: \pm 1% at 25°C
Relay outputs	R1A, R1B, R1C	1 protected relay output, 1 N/O contact and 1 N/C contact with common point Response time: 30 ms maximum Minimum switching capacity: 5 mA for 24 V \pm Maximum switching capacity: <ul style="list-style-type: none"> ■ On resistive load ($\cos \varphi = 1$ and L/R = 0 ms): 3 A at 250 V \sim or 4 A at 30 V \pm ■ On inductive load ($\cos \varphi = 0.4$ and L/R = 7 ms): 2 A at 250 V \sim or 30 V \pm
LI logic inputs	LI1...LI4	4 programmable logic inputs, compatible with PLC level 1, standard IEC/EN 61131-2 24 V \pm internal power supply or 24 V \pm external power supply (min. 18 V, max. 30 V) Sampling time: < 20 ms Sampling time tolerance: \pm 1 ms Factory-set with 2-wire control in "transition" mode for machine safety reasons: <ul style="list-style-type: none"> ■ LI1: forward ■ LI2...LI4: not assigned Multiple assignment makes it possible to configure several functions on one input (for example: LI1 assigned to forward and preset speed 2, LI3 assigned to reverse and preset speed 3) Impedance 3.5 k Ω
	Positive logic (Source)	Factory setting State 0 if < 5 V, state 1 if > 11 V
	Negative logic (Sink)	Software-configurable State 0 if > 16 V or logic input not wired, state 1 if < 10 V
Logic output	LO+	One 24 V \pm logic output assignable as positive logic (Source) or negative logic (Sink) open collector type, compatible with level 1 PLC, standard IEC/EN 61131-2 Maximum voltage: 30 V Linearity: \pm 1% Maximum current: 10 mA (100 mA with external power supply) Impedance: 1 k Ω Update time: < 20 ms Logic output common (LO-) to be connected to: <ul style="list-style-type: none"> ■ 24 V \pm in positive logic (Source) ■ 0 V in negative logic (Sink)
Maximum I/O wire size and tightening torque		1.5 mm ² (AWG 14) 0.5 Nm
Acceleration and deceleration ramps		Ramp profile: <ul style="list-style-type: none"> ■ Linear from 0 to 999.9 s ■ S ramp ■ U ramp Automatic adaptation of deceleration ramp time if braking capacities exceeded, although this adaptation can be disabled (use of braking unit)
Emergency braking		By DC injection: automatically as soon as the estimated output frequency drops to < 0.2 Hz, period adjustable from 0.1 to 30 s or continuous, current adjustable from 0 to 1.2 I _n
Main drive protection features		Thermal protection against overheating Protection against short-circuits between motor phases Overcurrent protection between motor phases and earth Protection in the event of line overvoltage and undervoltage Input phase loss protection, in three-phase
Motor protection		Thermal protection integrated in the drive by continuous calculation of the I ² t
Frequency resolution		Display unit: 0.1 Hz Analog inputs: 10-bit A/D converter
Time constant on a change of setpoint	ms	20 \pm 1 ms

Communication port characteristics

Protocol		Modbus
Structure	Connector	1 RJ45 connector
	Physical interface	2-wire RS 485
	Transmission mode	RTU
	Transmission speed	Configurable via the Human-Machine interface, remote display terminal or SoMove setup software: 4800 bps, 9600 bps, 19200 bps or 38400 bps
	Number of subscribers	31 maximum
	Polarization	No polarization impedance. This must be provided by the wiring system (for example, in the master)
	Address	1 to 247, configurable via the Human-Machine interface, remote display terminal or SoMove setup software
Services	Profile	Based on IEC 61800-7-301 (CiA 402 profile)
	Messaging	Read Holding Registers (03) 29 words maximum Write Single Register (06) 29 words maximum Write Multiple Registers (16) 27 words maximum Read/Write Multiple Registers (23) 4/4 words maximum Read Device Identification (43)
	Communication monitoring	Can be inhibited. Time out can be set between 0.1 s and 30 s
Diagnostics	Via the Human-Machine interface or remote display terminal	On display unit

Torque characteristics (typical curves)

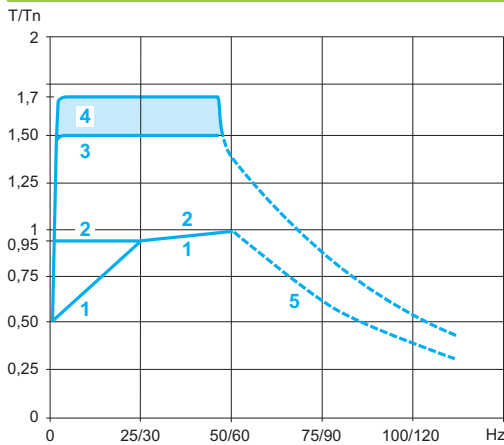

The curves opposite define the available continuous torque and transient overtorque for both self-cooled and force-cooled motors. The only difference is in the ability of the motor to provide a high continuous torque at less than half the nominal speed.

- 1 Self-cooled motor: continuous useful torque (1)
- 2 Force-cooled motor: continuous useful torque
- 3 Transient overtorque for 60 s
- 4 Transient overtorque for 2 s
- 5 Torque in overspeed at constant power (2)

(1) For power ratings ≤ 250 W, derating is 20% instead of 50% at very low frequencies.
(2) The nominal motor frequency and the maximum output frequency can be adjusted from 0.5 to 400 Hz. The mechanical overspeed capability of the selected motor must be checked with the manufacturer.

Special uses

Use with a motor with different power to the drive rating

The device can power any motor which has a lower rating than that for which the drive was designed, provided that the minimum current value is complied with: $I_{th} = 0.2 \times \text{drive } I_n$.
For motor ratings slightly higher than that of the drive, check that the current taken does not exceed the continuous output current of the drive.

Connecting motors in parallel

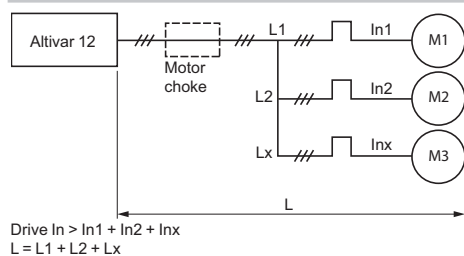

Connecting motors in parallel

The drive rating must be greater than or equal to the sum of the currents of the motors to be connected to the drive (I_n). In this case, it is necessary to provide external thermal protection for each motor using probes or thermal overload relays.

Use of a motor choke (1) is recommended in the following cases:

- When three or more motors are connected in parallel
- When the motor cable length (L), including all tap links ($L_1, L_2 \dots L_x$), is longer than the maximum permitted motor cable length (2)

(1) See References on page 17.
(2) For maximum permitted motor cable length, see page 11.

Motor switching at the drive output

Motor switching is possible with the drive unlocked. The integrated protection in Altivar 12 drives offers better immunity to downstream breaking of the powered motor.

Variable speed drives

Altivar 12

Drives with heatsink, drives on a base plate



ATV 12H018M2



ATV 12H075M2



ATV 12HU40M3



ATV 12PU22M3



ATV 12HU15M2TQ (8)

Drives with heatsink

Motor Power indicated on rating plate (1)	Line supply				Altivar 12				Reference	Weight (2)
	Max. line current (3)	Apparent power		Max. prospective line Isc	Maximum continuous output current (In) (1)	Maximum transient current for 60 s	Dissipated power at maximum output current (In) (1)			
		at U1	at U2					at U2		
kW	HP	A	A	kVA	kA	A	A	W	kg	
Single-phase supply voltage: 100...120 V 50/60 Hz (4)										
0.18	0.25	6	5	1	1	1.4	2.1	18	ATV 12H018F1 (5)	0.700
0.37	0.5	11.4	9.3	1.9	1	2.4	3.6	29	ATV 12H037F1	0.800
0.75	1	18.9	15.7	3.3	1	4.2	6.3	48	ATV 12H075F1	1.300

Single-phase supply voltage: 200...240 V 50/60 Hz (4) (6)										
0.18	0.25	3.4	2.8	1.2	1	1.4	2.1	18	ATV 12H018M2 (5) (7)	0.700
0.37	0.55	5.9	4.9	2	1	2.4	3.6	27	ATV 12H037M2 (7)	0.700
0.55	0.75	8	6.7	2.8	1	3.5	5.3	34	ATV 12H055M2 (7)	0.800
0.75	1	10.2	8.5	3.5	1	4.2	6.3	44	ATV 12H075M2 (7)	0.800
1.5	2	17.8	14.9	6.2	1	7.5	11.2	72	ATV 12HU15M2 (8)	1.400
2.2	3	24	20.2	8.4	1	10	15	93	ATV 12HU22M2 (8)	1.400

Three-phase supply voltage: 200...240 V 50/60 Hz (4)										
0.18	0.25	2	1.7	0.7	5	1.4	2.1	16	ATV 12H018M3 (5)	0.700
0.37	0.55	3.6	3	1.2	5	2.4	3.6	24	ATV 12H037M3	0.800
0.75	1	6.3	5.3	2.2	5	4.2	6.3	41	ATV 12H075M3	0.800
1.5	2	11.1	9.3	3.9	5	7.5	11.2	73	ATV 12HU15M3	1.200
2.2	3	14.9	12.5	5	5	10	15	85	ATV 12HU22M3	1.200
3	–	19	15.9	6.6	5	12.2	18.3	94	ATV 12HU30M3	2.000
4	5	23.8	19.9	8.3	5	16.7	25	128	ATV 12HU40M3	2.000

Drives on a base plate

Single-phase supply voltage: 100...120 V 50/60 Hz (4)										
0.18	0.25	6	5	1	1	1.4	2.1	18	ATV 12H018F1 (5)	0.700
–	–	11.4	9.3	1.9	1	2.4	3.6	29	ATV 12P037F1 (9)	0.700

Single-phase supply voltage: 200...240 V 50/60 Hz (4) (6)										
0.18	0.25	3.4	2.8	1.2	1	1.4	2.1	18	ATV 12H018M2 (5) (7)	0.700
–	–	5.9	4.9	2	1	2.4	3.6	27	ATV 12P037M2 (9)	0.700
–	–	8	6.7	2.8	1	3.5	5.3	34	ATV 12P055M2 (9)	0.700
–	–	10.2	8.5	3.5	1	4.2	6.3	44	ATV 12P075M2 (9)	0.700

Three-phase supply voltage: 200...240 V 50/60 Hz (4)										
0.18	0.25	2	1.7	0.7	5	1.4	2.1	16	ATV 12H018M3 (5)	0.700
–	–	3.6	3	1.2	5	2.4	3.6	24	ATV 12P037M3 (9)	0.700
–	–	6.3	5.3	2.2	5	4.2	6.3	41	ATV 12P075M3 (9)	0.700
–	–	11.1	9.3	3.9	5	7.5	11.2	73	ATV 12PU15M3 (9)	1.000
–	–	14.9	12.5	5	5	10	15	85	ATV 12PU22M3 (9)	1.000
–	–	19	15.9	6.6	5	12.2	18.3	94	ATV 12PU30M3 (9)	1.600
–	–	23.8	19.9	8.3	5	16.7	25	128	ATV 12PU40M3 (9)	1.600

(1) These values are given for a nominal switching frequency of 4 kHz, for use in continuous operation. If operation above 4 kHz needs to be continuous, the nominal drive current should be derated by 10% for 8 kHz, 20% for 12 kHz and 30% for 16 kHz.

The switching frequency can be set between 2 and 16 kHz for all ratings.

Above 4 kHz, the drive will reduce the switching frequency automatically in the event of an excessive temperature rise.

See the derating curves in the User Manual, available on our website at "www.schneider-electric.com".

(2) Weight of product without packaging.

(3) Typical value for the indicated motor power and for the maximum prospective line Isc.

(4) Min. (U1) and max. (U2) nominal supply voltage: 100 (U1)...120 V (U2), 200 (U1)...240 V (U2).

(5) Due to the poor heat dissipation, the ATV 12H018●● drive is only supplied as a base plate version.

(6) Drive supplied with category C1 integrated EMC filter. This filter can be disconnected.

(7) Available in lots of 14: add **TQ** at the end of the reference. For example, ATV 12H018M2 becomes **ATV 12H018M2TQ**.

(8) Available in lots of 7: add **TQ** at the end of the reference. ATV 12HU22M2 becomes **ATV 12HU22M2TQ**.

(9) To size the ATV 12P●●●● drive correctly, see the specific manual for the Altivar 12 base plate version, available on our website at "www.schneider-electric.com".



Configuring the drive in its packaging with the Multi-Loader tool
VW3 A8 121+ cordset
VW3 A8 126

Accessories

Description	For drives	Reference	Weight kg
Mounting plates for mounting on 35 mm wide U rail	ATV 12H018F1, H037F1	VW3 A9 804	0.290
	ATV 12H018M2...H075M2		
	ATV 12H018M3...H075M3	VW3 A9 805	0.385
	ATV 12H075F1		
ATV 12HU15M2, HU22M2			
	ATV 12HU15M3, HU22M3	VW3 A9 806	0.410
	ATV 12HU30M3, HU40M3		
	ATV 12H018F1, H037F1	VW3 A9 523	0.170
ATV 12H018M2...H075M2			
EMC conformity kits These provide a connection compliant with EMC standards (see page 23) The kit consists of: ■ The EMC plate ■ Clamps ■ Fixing accessories	ATV 12H018M3...H075M3	VW3 A9 524	0.190
	ATV 12P037F1		
	ATV 12P037M2...P075M2		
	ATV 12P037M3...P075M3		
ATV 12H075F1	ATV 12HU15M2, HU22M2	VW3 A9 524	0.190
	ATV 12HU15M3, HU22M3		
	ATV 12PU15M3, PU22M3		
+15 V/+24 V voltage converter Connects directly to the control terminals	ATV 12●●●●●●	VW3 A9 317	–

Configuration tools

Description	For drives	Reference	Weight kg
SoMove lite setup software and associated accessories			
SoMove lite setup software For configuring, adjusting and debugging the Altivar 12 drive. Downloadable from our website "www.schneider-electric.com" or available on the "Description of the Motion & Drives Offer" DVD ROM VW3 A8 200.	ATV 12●●●●●●	–	–
USB/RJ45 cable equipped with a USB connector and an RJ45 connector. For connecting a PC to the Altivar 12 drive. Length: 2.5 m	ATV 12●●●●●●	TCSMCNAM3M002P	–
Modbus - Bluetooth® adaptor For establishing a Bluetooth® wireless connection between the Altivar 12 drive and a PC equipped with a Bluetooth® wireless link. Pack contents: ■ 1 Bluetooth® adaptor (range 10 m, class 2) with an RJ45 connector ■ 1 x 0.1 m cordset with 2 RJ 45 connectors, ... (1)	ATV 12●●●●●●	VW3 A8 114	0.155
USB - Bluetooth® adaptor for PC Required for a PC which is not equipped with Bluetooth® technology. Connects to a USB port on the PC. Range of 10 m (class 2).	–	VW3 A8 115	0.200
Simple Loader, Multi-Loader configuration tools and associated cable			
Simple Loader tool For duplicating one drive configuration on another drive. The drives must be powered-up. The tool is supplied with a cordset equipped with 2 RJ45 connectors.	ATV 12●●●●●●	VW3 A8 120	–
Multi-Loader tool 1 For copying a configuration on a PC or drive and duplicating it on another drive. The drives do not need to be powered-up. Supplied with the tool: ■ 1 cordset equipped with 2 RJ45 connectors ■ 1 cordset equipped with a USB type A connector and a USB Mini-B type connector ■ 1 x 2 GB SD memory card ■ 1 female/female RJ45 adaptor ■ 4 AA/LR6 1.5 V batteries	ATV 12●●●●●●	VW3 A8 121	–
Cordset for Multi-Loader tool 2 For connecting the Multi-Loader tool to the Altivar 12 drive in its packaging. Equipped with a non-locking RJ45 connector with special mechanical catch on the drive end and an RJ45 connector on the Multi-Loader end.	ATV 12●●●●●● in its packaging	VW3 A8 126	–

(1) Also includes other components for connecting compatible Schneider Electric devices.

Variable speed drives

Altivar 12

Configuration tools, remote display terminals, braking unit and resistors, additional EMC filters



VW3 A1 006 with cover open: RUN, FWD/REV and STOP buttons accessible



VW3 A7 701



VW3 A4 416



ATV 12H075M2 with EMC kit VW3 A9 523 mounted on EMC filter VW3 A4 416

Configuration tools (continued)

Description	For drives	Reference	Weight kg
SoMove Mobile software for mobile phone (1)			
SoMove Mobile software allows you to edit drive parameters from a mobile phone using a Bluetooth® wireless connection. Requires the Modbus - Bluetooth® adaptor VW3 A8 114 (see page 15). It can also be used to back up configurations, which can be imported or exported from a PC. SoMove Mobile software can be downloaded from our website "www.schneider-electric.com".	ATV 12●●●●●●	-	-

Remote display terminals and associated cordsets

Remote display terminals	IP 54 degree of protection	ATV 12●●●●●●	VW3 A1 006	0.250
For mounting the Human-Machine interface on an enclosure door with IP 54 or IP 65 degree of protection. A remote-mounting cordset VW3 A1 104 R●● is also required.	IP 65 degree of protection	ATV 12●●●●●●	VW3 A1 007	0.275
Remote-mounting cordsets equipped with 2 RJ45 connectors. For connecting the VW3 A1 006 or VW3 A1 007 remote display terminal to the Altivar 12 drive.	Length: 1 m	ATV 12●●●●●●	VW3 A1 104 R10	0.050
	Length: 3 m	ATV 12●●●●●●	VW3 A1 104 R30	0.150

Braking unit and resistors

Description	Ohmic value at 20°C	Average power available at 40°C	For drives	Reference	Weight kg
	Ω	W			
Resistance braking unit To be connected to the DC bus. Needs at least one braking resistor. For mounting on a 35 mm AM1 ED L rail, to be ordered separately (2).	-	-	ATV 12●●●●F1 ATV 12●●●●M2 ATV 12H018M3...HU22M3 ATV 12P037M3...PU22M3	VW3 A7 005	0.285
Braking resistors Protected (IP 20) If a resistor other than those specified is being used, add a thermal protection device.	100	58	ATV 12●●●●F1 (3) ATV 12H018M2...HU15M2 (3) ATV 12H018M3...HU15M3 (3) ATV 12P037M2...P075M2 (3) ATV 12P037M3...PU15M3 (3)	VW3 A7 701	1.580
	60	115	ATV 12HU22M2 (4) ATV 12HU22M3 (4) ATV 12PU22M3 (4)	VW3 A7 702	1.660
Braking resistors Unprotected (IP 00) If a resistor other than those specified is being used, add a thermal protection device.	100	32	ATV 12●●●●F1 (3) ATV 12H018M2...HU15M2 (3) ATV 12H018M3...HU15M3 (3) ATV 12P037M2...P075M2 (3) ATV 12P037M3...PU15M3 (3)	VW3 A7 723	0.605
	68	32	ATV 12HU22M2 (4) ATV 12HU22M3 (4) ATV 12PU22M3 (4)	VW3 A7 724	0.620

Additional EMC input filters

Description	For drives	Reference	Weight kg
Additional EMC input filters For compliance with the requirements of standard IEC/EN 61800-3, category C1, C2 or C3, in Environment 1 (public network) or 2 (industrial network), depending on the drive rating. See the "Conducted and radiated EMC emissions" characteristics on page 10 to check the permitted shielded motor cable lengths depending on the category and the environment according to standard IEC/EN 61800-3.	ATV 12H018F1...H037F1 ATV 12H018M2...H075M2 ATV 12P037F1 ATV 12P037M2...P075M2	VW3 A4 416	1.120
	ATV 12H075F1 ATV 12HU15M2, HU22M2	VW3 A4 417	1.455
	ATV 12H018M3...H075M3 ATV 12P037M3...P075M3	VW3 A4 418	1.210
	ATV 12HU15M3, HU22M3 ATV 12PU15M3, PU22M3	VW3 A4 419	1.440

(1) The SoMove Mobile software requires a basic mobile phone; please consult our website "www.schneider-electric.com".
 (2) Please consult our website "www.schneider-electric.com".
 (3) Minimum value of the resistor to be used: 75 ohms.
 (4) Minimum value of the resistor to be used: 51 ohms.

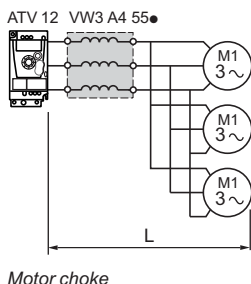

Motor choke

Motor chokes

Description	Nominal current A	For drives	Reference	Weight kg
Motor chokes Required: <ul style="list-style-type: none"> When connecting more than 2 motors in parallel When the motor cable length (L), including tap-offs, is: <ul style="list-style-type: none"> 50...100 m for a shielded motor cable (1), 100...200 m for an unshielded motor cable (1). 	4	ATV 12H018F1, H037F1 ATV 12H018M2...H055M2 ATV 12H018M3, H037M3 ATV 12P037F1 ATV 12P037M2, P055M2 ATV 12P037M3	VW3 A4 551	1.880
	10	ATV 12H075F1 ATV 12H075M2, HU15M2 ATV 12H075M3, HU15M3 ATV 12P075M2 ATV 12P075M3, PU15M3	VW3 A4 552	3.700
	16	ATV 12HU22M2 ATV 12HU22M3, HU30M3 ATV 12PU22M3, PU30M3	VW3 A4 553	4.100
	30	ATV 12HU40M3 ATV 12PU40M3	VW3 A4 554	6.150

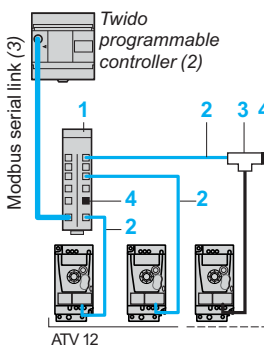

Example of Modbus diagram with connection via splitter box and RJ45 connectors

Modbus serial link

Description	Item no.	Length m	Unit reference	Weight kg	
Connection via splitter box and RJ45 connectors					
Modbus splitter box 10 RJ45 connectors and 1 screw terminal	1	–	LU9 GC3	0.500	
Cordsets for Modbus serial link equipped with 2 RJ45 connectors	2	0.3	VW3 A8 306 R03	0.025	
		1	VW3 A8 306 R10	0.060	
		3	VW3 A8 306 R30	0.130	
Modbus T-junction boxes (with integrated cable)	3	0.3	VW3 A8 306 TF03	0.190	
		1	VW3 A8 306 TF10	0.210	
Line terminators	R = 120 Ω	4	–	VW3 A8 306 RC	0.010
(4) (5)	C = 1 nF				
For RJ45 connector	R = 150 Ω	4	–	VW3 A8 306 R	0.010

Documentation

Description	For drives	Reference	Weight kg
“Description of the Motion & Drives Offer” DVD ROM Contents (6): <ul style="list-style-type: none"> Technical documentation (programming manuals, installation manuals, quick reference guides) SoMove lite setup software, catalogues Brochures 	ATV 12●●●●●●	VW3 A8 200	0.100



VZ3 V1 302

Replacement parts

Description	For drives	Reference	Weight kg
Fans	ATV 12H075F1	VZ3 V1 301	0.160
	ATV 12HU15M2, HU22M2		
	ATV 12HU15M3...HU40M3	VZ3 V1 302	0.150

(1) Motor cable length given for a switching frequency of 4 kHz.
 (2) Please refer to the Twido programmable controller catalogue.
 (3) Cable depends on the type of controller or PLC.
 (4) Order in multiples of 2.
 (5) Depends on the bus architecture.
 (6) The content of this DVD ROM is also available on our website at "www.schneider-electric.com".

Drives with heatsinks (1)

ATV 12H018F1, H037F1, ATV 12H018M2...H075M2, ATV 12H018M3...H075M3

Drive with EMC conformity kit VW3 A9 523 (available as an option)

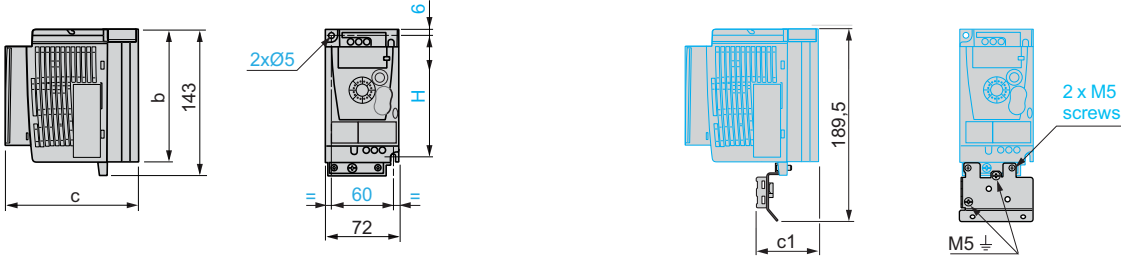

ATV 12	b	c	c1	H
H018F1 (1), H018M2 (1), H018M3 (1)	142	102.2	34	131
H037F1, H037M2, H037M3	130	121.2	53	120
H055M2, H075M2, H075M3	130	131.2	63	120

(1) Due to the poor heat dissipation, ATV 12H018●● drives are only available as a base plate version. They can either be mounted conventionally (drive on heatsink) or on the machine frame (drive on base plate).

ATV 12H075F1, ATV 12HU15M2, HU22M2, ATV 12HU15M3, HU22M3

Drive with EMC conformity kit VW3 A9 524 (available as an option)

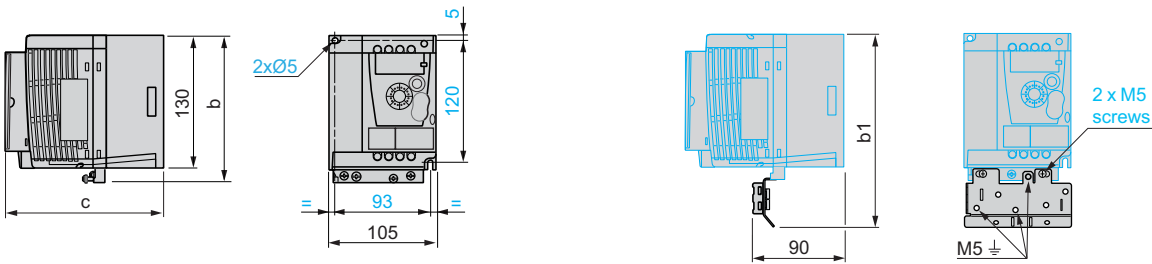

ATV 12	b	b1	c
H075F1, HU15M2, HU22M2	142	188.2	156.2
HU15M3, HU22M3	143	189.3	131.2

ATV 12HU30M3, HU40M3

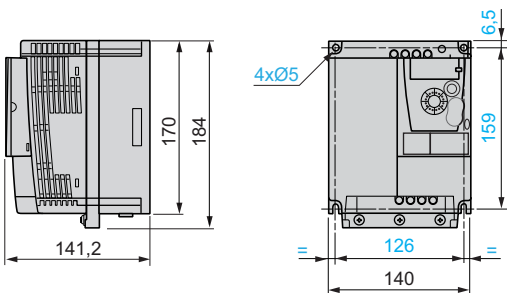

Drives on a base plate

ATV 12P037F1, ATV 12P037M2...P075M2, ATV 12P037M3...P075M3

Drive with EMC conformity kit VW3 A9 523 (available as an option)



ATV 12PU15M3, PU22M3

Drive with EMC conformity kit VW3 A9 524 (available as an option)

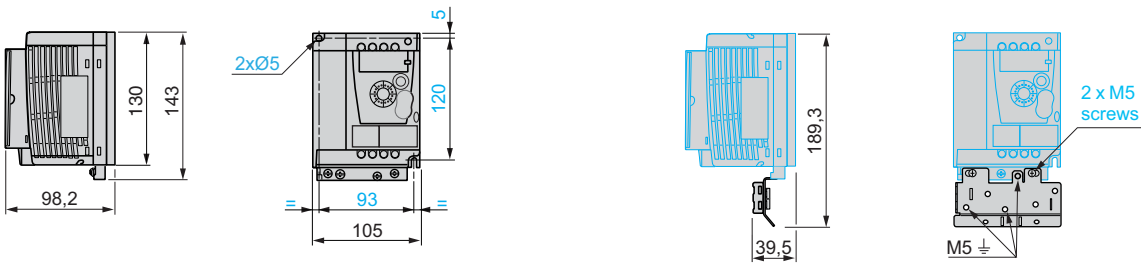

ATV 12PU30M3, PU40M3

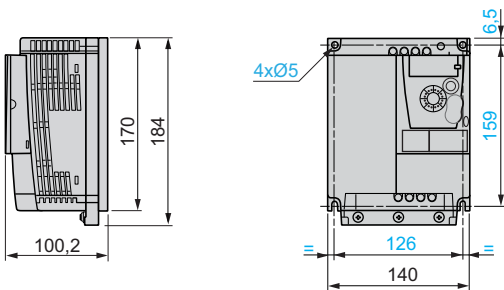

Recommendations for mounting on the machine frame (specific to ATV 12P●●●● drives)

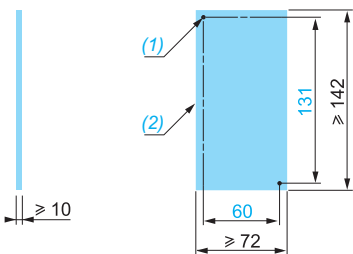

Example of cooling area for ATV 12P037M2

- (1) 2 x Ø M4 tapped holes
- (2) Minimum machined area

Note: The general rules set out below should be adapted to suit the operating environment. Please refer to the specific manual for the Altivar 12 base plate version, available on our website at "www.schneider-electric.com".

ATV 12P●●●● drives can be mounted on (or in) a steel or aluminium machine frame, observing the following conditions:

- Maximum ambient temperature: 40°C
- Vertical mounting at ± 10°
- The drive must be mounted at the centre of a support (frame) with high thermal conductivity
- Support area for the drive machined on the frame with a surface smoothness of 100 µm max and unevenness of 3.2 µm max.

When the operating conditions are close to the maximum limits (power, cycle and temperature) this type of use must be checked beforehand, by monitoring the thermal state of the drive.

Accessories

Mounting plates for mounting on an AM1 ED 35 mm rail

VW3 A9 804

VW3 A9 805

VW3 A9 806

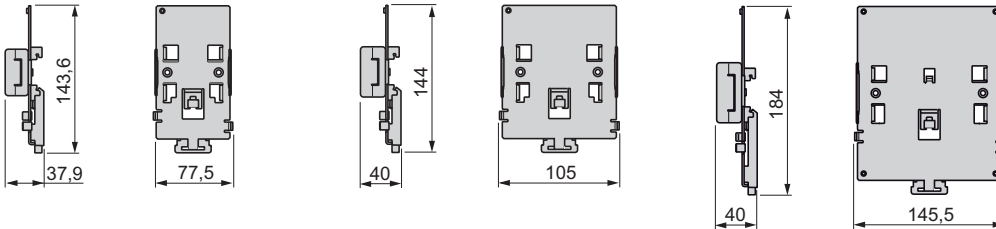

Options

Remote display terminal

VW3 A1 006

Braking unit

VW3 A7 005

(mounting on 35 mm AM1 ED rail)

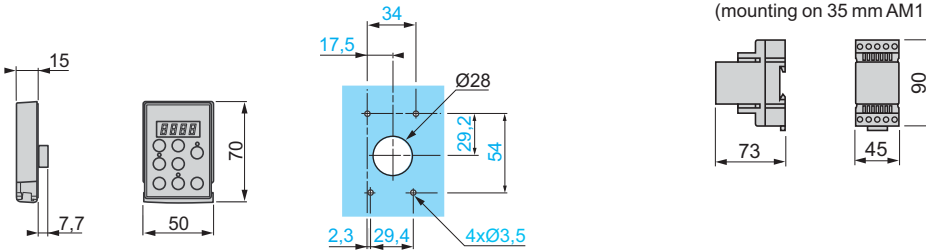

Braking resistors

VW3 A7 701, 702

VW3 A7 723, 724

(2 flying leads 0.5 m long)

Mounting recommendations

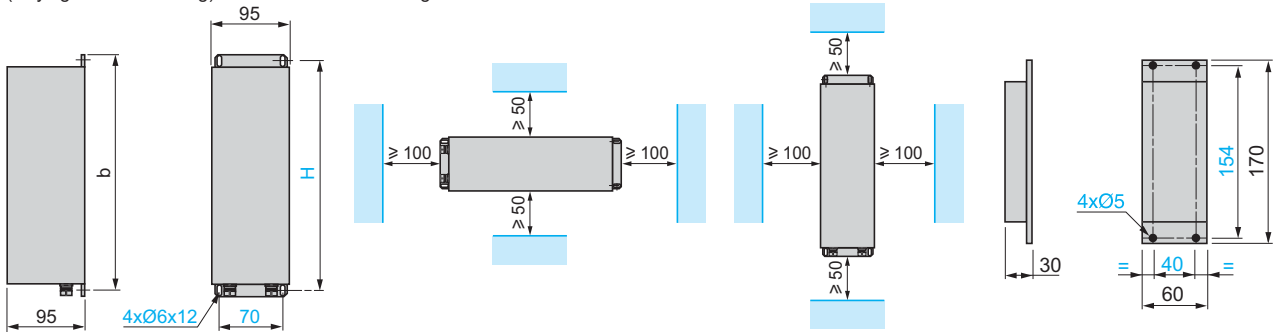

VW3	b	H
A7 701	295	275
A7 702	395	375

Motor chokes

VW3 A4 551...554

Additional EMC input filters

VW3 A4 416...419



VW3	a	b	c	c1	G	G1	H	Ø
A4 551	100	135	55	60	40	60	42	6 x 9
A4 552, A4 553	130	155	85	90	60	80.5	62	6 x 12
A4 554	155	170	115	135	75	107	90	6 x 12

VW3	a	b	c	G	H
A4 416	75	194	30	61	180
A4 417	117	184	40	97	170
A4 418	75	194	40	61	180
A4 419	117	190	40	97	170

Mounting recommendations

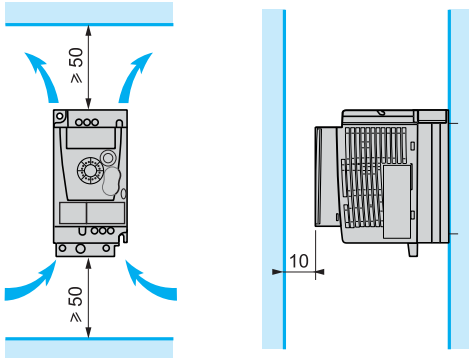

- Install the unit vertically, at $\pm 10^\circ$.
- Avoid placing it close to heating elements.
- Leave sufficient free space to ensure that the air required for cooling purposes can circulate, by natural convection or by ventilation, from the bottom to the top of the unit.

Operating temperature according to the mounting type

Mounting type

Drives with natural convection

ATV 12H018F1, H037F1
ATV 12H018M2...H075M2
ATV 12H018M3...H075M3

Ambient air temperature (1)

-10...+40°C
Up to +50°C with current derating of 2% per additional degree above 40°C

Drives with fan

ATV 12H075F1
ATV 12HU15M2, HU22M2
ATV 12HU15M3...HU40M3

Ambient air temperature (1)

-10...+50°C

Type A mounting

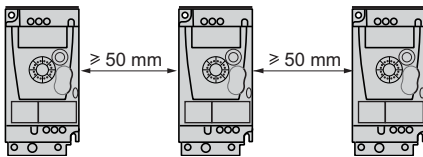

Type B mounting (2)

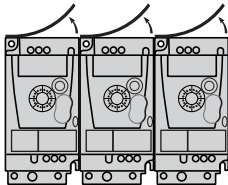

-10...+40°C (3)
Up to +60°C with current derating of 2% per additional degree above 40°C

-10...+50°C
Up to +60°C with current derating of 2% per additional degree above 50°C

Type C mounting (2)

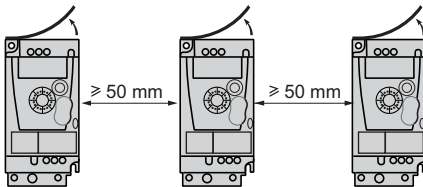

-10...+40°C
Up to +60°C with current derating of 2% per additional degree above 40°C
-10...+50°C on metal plate

-10...+50°C
Up to +60°C with current derating of 2% per additional degree above 50°C

(1) Value given for a switching frequency of 4 kHz, for use in continuous operation. If operation above 4 kHz needs to be continuous, the nominal drive current should be derated by 10% for 8 kHz, 20% for 12 kHz and 30% for 16 kHz.

Above 4 kHz, the drive will reduce the switching frequency automatically in the event of an excessive temperature rise. See the derating curves in the User Manual, available on our website at "www.schneider-electric.com".

(2) Remove the protective cover from the top of the drive.

(3) Maximum value depending on the drive rating and operating conditions; see the derating curves in the User Manual, available on our website at "www.schneider-electric.com".

Recommended schemes

Typical scheme for ATV 12●●●●F1, ATV 12●●●●M2

Single-phase power supply

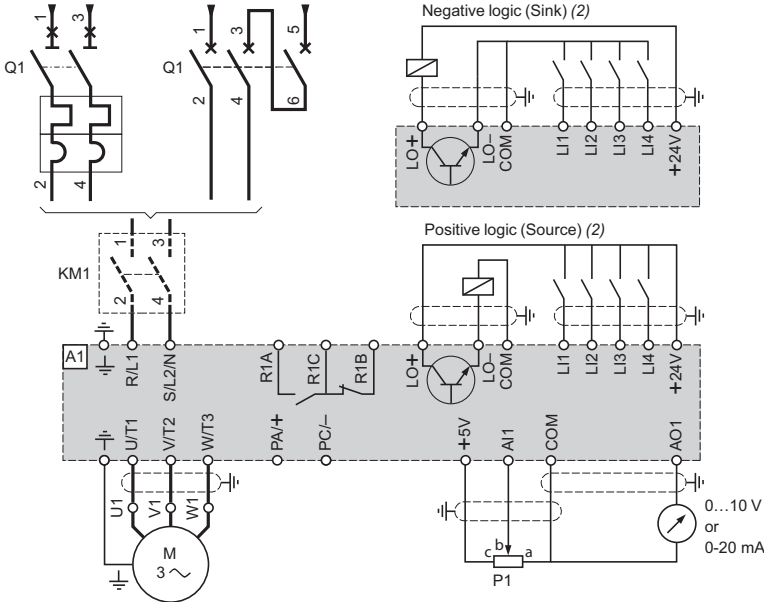

Typical scheme for ATV 12●●●●M3

Three-phase power supply (power section) (1)

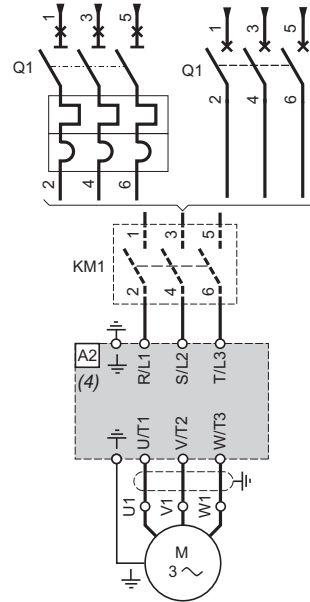

Note: Install interference suppressors on all inductive circuits near the drive or connected on the same circuit, such as relays, contactors, solenoid valves, fluorescent lighting, etc.

Compatible components (for a complete list of references, please refer to the "Motor starter solutions - Control and protection components" and "Motor starters up to 150 A" catalogues or visit "www.schneider-electric.com")

Item no.	Description
A1	ATV 12●●●●F1 or ATV 12●●●●M2 drive (see page 14)
A2	ATV 12●●●●M3 drive (see page 14)
KM1	Contactors (only if a control circuit is needed; see page 24)
P1	2.2 kΩ reference potentiometer, SZ1 RV1202. This can be replaced by a 10 kΩ potentiometer (maximum).
Q1	Circuit breaker (see page 24)

Examples of recommended schemes for logic and analog I/O

2-wire control

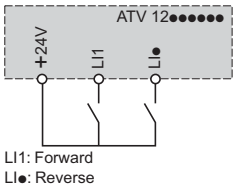

3-wire control

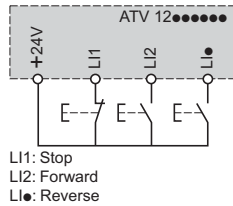

Analog input configured for voltage

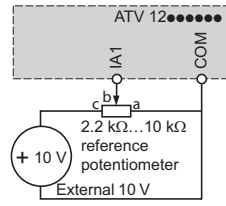

Analog input configured for current

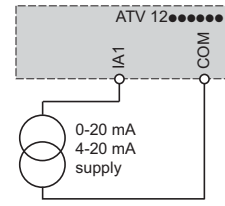

Examples of recommended schemes for logic I/O powered by an external 24 V AC supply (5)

Connected as positive logic (Source)

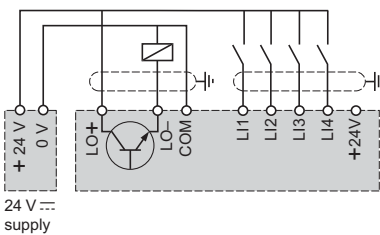

Connected as negative logic (Sink)

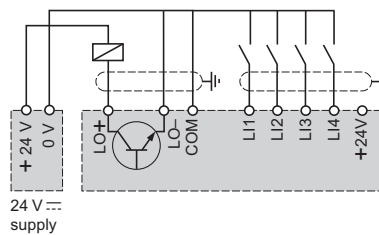

- (1) The control section is connected in exactly the same way as for the ATV 12●●●●F1 and ATV 12●●●●M2 drives.
- (2) Connection as positive logic (Source) or negative logic (Sink) is configured via parameters; the factory-set configuration is positive logic (Source).
- (3) Fault relay contacts for remote signalling of the drive status.
- (4) The R/L1, S/L2/N and T/L3 terminals are connected at the top of the drive. The other terminals are connected on the underside of the drive.
- (5) Please refer to the "Phase power supplies and transformers" catalogue.

Recommended schemes (continued)

Braking unit VW3 A7 005 used with braking resistors VW3 A7 701, 702, 723, 724

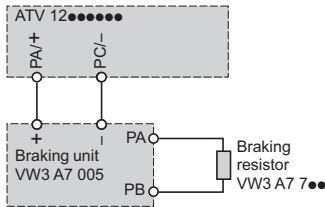

Motor chokes VW3 A4 551...554

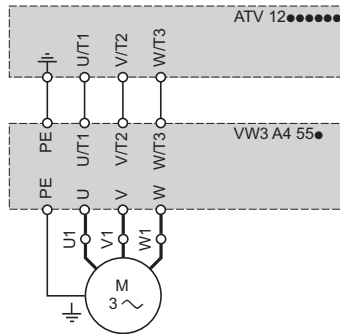

Additional EMC input filters VW3 A4 416...419

Single-phase power supply

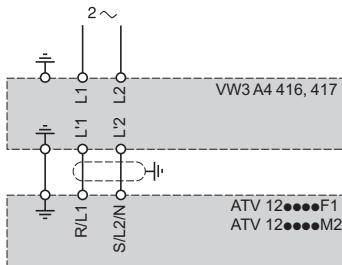

Three-phase power supply

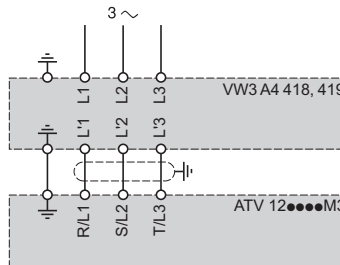

Connections for ensuring conformity to EMC standards

Principle

- Earths between the drive, motor and cable shielding must have "high frequency" equipotentiality.
- Use shielded cables with shielding connected to earth throughout 360° at both ends for the motor cable and the control-signalling cables. Conduit or metal ducting can be used for part of the shielding length provided that there is no break in the continuity of the earth connection.
- Ensure maximum separation between the line supply cable and the motor cable.

Installation diagram

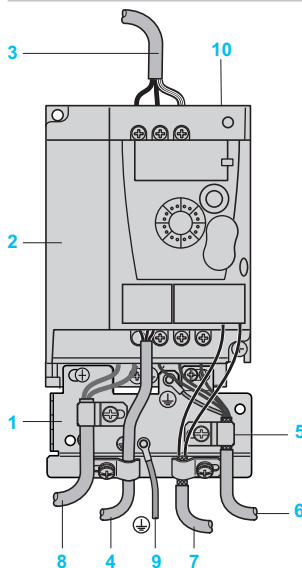

- 1 Metal plate to be mounted on ATV 12●●●●F1, ATV 12●●●●M2 and ATV 12H018M3...●U22M3 drives (earthed casing).
- 2 ATV 12●●●●F1, ATV 12●●●●M2 and ATV 12H018M3...●U22M3 drives
- 3 Unshielded power supply wires or cable
- 4 Unshielded wires or cable for the output of the fault relay contacts
- 5 Shielding of cables 6 and 7 attached and earthed as close as possible to the drive:
 - Strip the cable to expose the shielding.
 - Attach the cable to the plate 1 by tightening the clamp on the stripped part of the shielding.

The shielding must be clamped tightly enough to the metal surface to ensure good contact.

For cables 6 and 7, the shielding must be connected to earth at both ends. The shielding must be continuous, and if intermediate terminals are used, they must be placed in EMC shielded metal boxes.
- 6 Shielded cable for connecting the motor
- 7 Shielded cable for connecting the control-signalling cables. For applications requiring several conductors, use cables with a small cross-section (0.5 mm²)
- 8 Unshielded cable for connecting the braking unit
- 9 PE cable (green-yellow)
- 10 Selector switch for disconnecting the integrated EMC filter on ATV 12●●●●M2 drives

Note: The HF equipotential earth connection between the drive, motor and cable shielding does not remove the need to connect the PE conductors (green-yellow) to the appropriate terminals on each unit. If using an additional EMC input filter, it should be mounted beneath the drive and connected directly to the line supply via an unshielded cable. Link 3 on the drive is then established via the filter output cable.

Use on an IT system (isolated or impedance earthed neutral)

Use a permanent insulation monitor, such as Schneider Electric's XM200, which is compatible with non-linear loads. ATV 12●●●●M2 drives have integrated EMC filters.

For use on an IT system, these filters can easily be disconnected by means of a selector switch 10 which can be accessed without removing the drive.

Variable speed drives

Altivar 12

Motor starters: Single-phase supply voltages 100...120 V and 200...240 V

Applications

The proposed combinations can:

- Protect people and equipment (when a short-circuit occurs)
- Maintain protection upstream of the drive in the event of a short-circuit on the power stage

Two types of combination are possible:

- Drive + circuit-breaker: Minimum combination
- Drive + circuit-breaker + contactor: Minimum combination with contactor when a control circuit is needed

Motor starters

Standard power ratings of three-phase 4-pole 50/60 Hz motors (2)	Variable speed drive	Combination with control circuit (circuit-breaker + contactor)			TeSys contactor (1)	
		Minimum combination (circuit-breaker only)				
kW	HP	TeSys motor circuit-breaker (3)	Operating range or rating	Maximum short-circuit current Icu		
		Modular circuit-breaker (4)				
		A	kA			
Single-phase supply voltage: 100...120 V 50/60 Hz (5)						
0.18	0.25	ATV 12H018F1	GV2 ME14	6...10	> 100	LC1 K09
			GV2 L10	6.3	> 100	
			2-pole C60N		10	10
0.37	0.5	ATV 12●037F1	GV2 ME16	9...14	> 100	LC1 K12
			GV2 L16	14	> 100	
			2-pole C60N		16	10
0.75	1	ATV 12H075F1	GV2 ME21	17...23	50	LC1 D25
			GV2 L22	25	> 50	
			2-pole C60N		20	10
Single-phase supply voltage: 200...240 V 50/60 Hz (5)						
0.18	0.25	ATV 12H018M2	GV2 ME08	2.5...4	> 100	LC1 K09
			GV2 L08	4	> 100	
			2-pole C60N		6	10
0.37	0.55	ATV 12●037M2	GV2 ME14	6...10	> 100	LC1 K09
			GV2 L10	6.3	> 100	
			2-pole C60N		10	10
0.55	0.75	ATV 12●055M2	GV2 ME14	6...10	> 100	LC1 K09
			GV2 L14	10	> 100	
			2-pole C60N		10	10
0.75	1	ATV 12●075M2	GV2 ME16	9...14	> 100	LC1 K12
			GV L16	14	> 100	
			2-pole C60N		16	10
1.5	2	ATV 12HU15M2	GV2 ME21	17...23	50	LC1 D18
			GV2 L20	18	> 100	
			2-pole C60N		20	10
2.2	3	ATV 12HU22M2	GV2 ME32	24...32	50	LC1 D25
			GV2 L22	25	50	
			2-pole C60N		32	10

(1) For a complete list of references for TeSys contactors, please refer to the "Motor starter solutions - Control and protection components" and "Motor starters up to 150 A" catalogues or visit "www.schneider-electric.com".

(2) Motor power indicated for combination with an ATV 12H●●●● drive with the same rating. For combination with an ATV 12P●●●● drive, refer to the specific manual for the Altivar 12 base plate version, available on our website at "www.schneider-electric.com".

(3) TeSys motor circuit-breakers:

- GV2 ME●●: Thermal magnetic motor circuit-breakers with pushbutton control
- GV2 L●●: Magnetic motor circuit-breakers with control by rotary knob

(4) 2-pole C60N modular circuit-breaker

(5) Can be integrated in devices connected to a power socket:

- If the line current is ≤ 16 A, connection to a single-phase power socket, 10/16 A 250 V ~
- If the line current is > 16 A, connection to a single-phase power socket conforming to standard IEC 60309

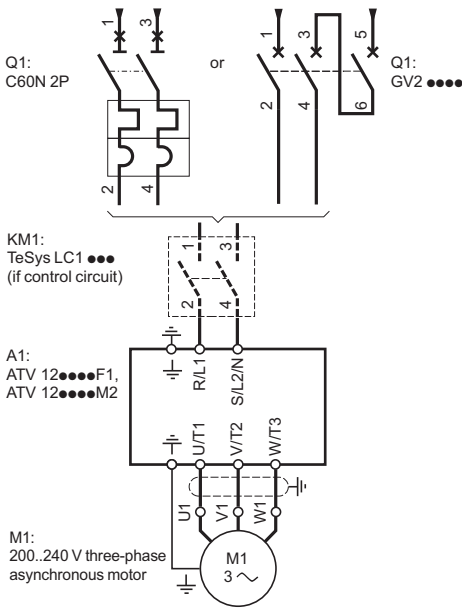

Motor starter with single-phase power supply

Variable speed drives

Altivar 12

Motor starters: Three-phase supply voltage
200...240 V

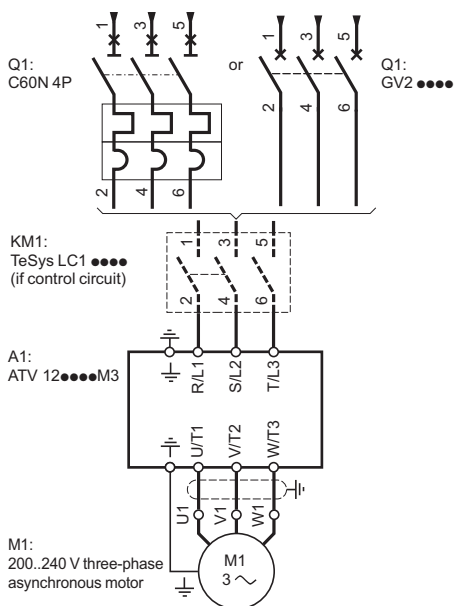

Motor starter with three-phase power supply

Motor starters (continued)

Standard power ratings of three-phase 4-pole 50/60 Hz motors (2)	Variable speed drive	Combination with control circuit (circuit-breaker + contactor)			TeSys contactor (1)	
		Minimum configuration (circuit-breaker only)		Maximum short-circuit current I _{cu}		
kW	HP		Operating range or rating		A	kA
M1	A1	Q1				KM1
Three-phase supply voltage: 200...240 V 50/60 Hz						
0.18	0.25	ATV 12H018M3	GV2 ME07	1.6...2.5	> 100	LC1 K09
			GV2 L07	2.5	> 100	
			4-pole C60N	6	10	
0.37	0.55	ATV 12●037M3	GV2 ME08	2.5...4	> 100	LC1 K09
			GV2 L08	4	> 100	
			4-pole C60N	6	10	
0.75	1	ATV 12●075M3	GV2 ME14	6...10	> 100	LC1 K09
			GV2 L14	10	> 100	
			4-pole C60N	10	10	
1.5	2	ATV 12●U15M3	GV2 ME16	9...14	> 100	LC1 K12
			GV L16	14	> 100	
			4-pole C60N	16	10	
2.2	3	ATV 12●U22M3	GV2 ME20	13...18	> 100	LC1 D18
			GV2 L20	18	> 100	
			4-pole C60N	20	10	
3	-	ATV 12●U30M3	GV2 ME21	17...23	50	LC1 D25
			GV2 L22	25	50	
			4-pole C60N	20	10	
4	5	ATV 12●U40M3	GV2 ME32	24...32	50	LC1 D25
			GV2 L22	25	50	
			4-pole C60N	32	10	

Combinations of C60N circuit-breakers/Vigi C60 add-on modules

C60N 2-pole/4-pole	Vigi C60		
Rating (A)	Rating (A)	Type (5)	Sensitivity
6	25	A "si"	30 mA
10	25	A "si"	30 mA
16	25	A "si"	30 mA
20	25	A "si"	30 mA
32	40	A "si"	30 mA

Recommendations for special uses:

- All RH10/RH21/RH99/RHU residual current protection devices with separate sensors are compatible as long as the type and sensitivity of the add-on modules given in the table above are observed.
- It is advisable to connect one RCD (residual current device) per drive. In this case, a type B RCD must not be located downstream of a type A or AC RCD.

(1) For a complete list of references for TeSys contactors, please refer to the "Motor starter solutions - Control and protection components" and "Motor starters up to 150 A" catalogues or visit "www.schneider-electric.com".

(2) Motor power indicated for combination with an ATV 12H●●●● drive with the same rating. For combination with an ATV 12P●●●● drive, refer to the specific manual for the Altivar 12 base plate version, available on our website at "www.schneider-electric.com".

(3) TeSys motor circuit-breakers:

- GV2 ME●●: Thermal magnetic motor circuit-breakers with pushbutton control
- GV2 L●●: Magnetic motor circuit-breakers with control by rotary knob

(4) 4-pole C60N modular circuit-breaker

(5) For additional protection against direct contact, with a three-phase power supply and access to the DC bus terminals (PA/+ and PC/-), the add-on module must be type B with a sensitivity of 30 mA.

Summary of functions	
Factory-set drive configuration	
Presentation	page 27
Human-Machine Interface (HMI)	
Description	page 27
Application functions	
Operating speed range	page 28
Preset speeds	page 28
Three additional high speeds	page 28
Control modes	page 28
PID regulator	page 29
Configuration of the logic input level	page 29
I/O monitoring	page 29
Operating direction: forward/reverse	page 29
2-wire control	page 29
3-wire control	page 29
Acceleration and deceleration ramp times	page 29
Ramp time switching	page 30
Acceleration and deceleration ramp profiles	page 30
Deceleration ramp adaptation	page 30
Stop types	page 30
Limiting low speed operating time	page 31
Configuration of analog input AI1	page 31
Automatic restart	page 31
Automatic catching of a spinning load with speed detection ("catch on the fly")	page 31
2nd current limit	page 32
Automatic DC injection	page 32
Motor control profiles	page 32
Switching frequency, noise reduction	page 32
Frequency jump	page 32
Jog mode	page 32
Fault relay, unlocking	page 33
Drive thermal protection	page 33
Motor thermal protection	page 33
Monitoring	page 33
Underload detection	page 34
Overload detection	page 34
Fault acknowledgment	page 34
Parameter protection by confidential code	page 34
Configuration of logic output LO+	page 34
Configuration of analog output AO1	page 34
Pump-specific application functions	
Control in single variable mode	page 35
Control in single variable mode with auxiliary pump	page 35
Underload detection	page 34
Overload detection	page 34
Sleep/Wake-up	page 36
PID feedback supervision	page 36
No-load operation detection	page 36
Quick start	page 37
Automatic restart on underload and overload fault	page 37
PID reference adjustment range for the end user	page 37
Incompatible functions	
Presentation	page 37

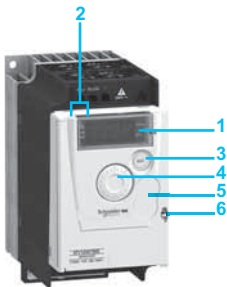

ATV 12H075M2 with door on front panel closed with protective cover 5: STOP/RESET and RUN buttons not accessible

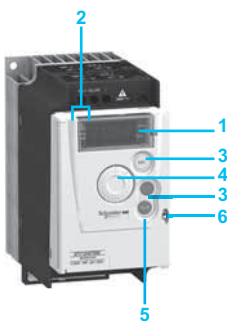

ATV 12H075M2 with door on front panel closed without protective cover 5: STOP/RESET and RUN buttons accessible

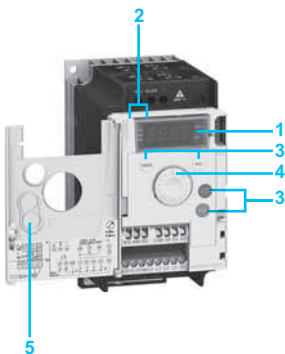

ATV 12H075M2 with door on front panel open

Factory-set drive configuration

The Altivar 12 drive is configured to allow immediate start-up without any adjustment for the majority of applications.

Factory-set configuration:

- Display: Displays the motor frequency reference
- Standard motor frequency: 50 Hz
- Motor supply voltage: 230 V three-phase
- Acceleration and deceleration ramp times: 3 s
- Low speed: 0 Hz
- High speed: 50 Hz
- Motor control profile: Standard (voltage/frequency)
- Slip compensation: 100%
- Motor thermal current: Same as the nominal motor current
- DC injection: 0.7 x nominal motor current for 0.5 s
- Switching frequency: 4 kHz
- Automatic adaptation of deceleration ramp
- 2-wire transition detection control: Logic input LI1 is assigned to forward, logic inputs LI2, LI3 and LI4 are not assigned
- Logic output LO+: Not assigned
- Analog input AI1: 5 V (speed reference)
- Analog output AO1: Not assigned
- Fault relay R1: 1 N/O contact (R1A, R1C) which opens in the event of a fault or when the drive is powered down

Human-Machine Interface (HMI)

Description

- 1 Display:
 - 4-digit display
 - Display of numeric values and codes
 - Unit rating of displayed value
- 2 Display of drive status:
 - “REF”: Reference mode. This mode is used to display the motor frequency reference of the active reference channel (terminals, local mode, remote display terminal or Modbus serial link). In local mode, the reference can be modified using the navigation button 4, if the function has been configured.
 - “MON”: Monitoring mode. This mode is used to display the monitoring parameters.
 - “CONF”: Configuration mode. This mode is used to configure the drive parameters. It offers direct access to the “MyMenu” menu which includes the 9 most commonly used parameters in standard applications. This list can be modified using the SoMove setup software and can contain up to 25 parameters. All configurable parameters can also be accessed with the “Full” menu for applications requiring further adjustment.

3 Using the buttons:

- “MODE”: Selects one of the following modes:
 - “REF” reference mode
 - “MON” monitoring mode
 - “CONF” configuration mode

Note: This button cannot be accessed when the door on the front panel is closed.

- “ESC”: Aborts a value, a parameter or a menu to return to the previous selection.
- “STOP/RESET”: Controls motor stopping and drive fault clearing locally; button active in factory-set configuration.
- “RUN”: Controls motor operation locally, if it has been programmed as active.

4 Using the navigation button:

- Rotation: Increases or decreases the parameter value, goes to the next parameter and can also be used to switch from one mode to another.
- Press: Saves the current value, selects the value.
- Option of using the button as a potentiometer in local mode.

5 Protective cover which can be removed to allow access to the STOP/RESET and RUN buttons

6 Mechanical lock for locking the door on the front panel

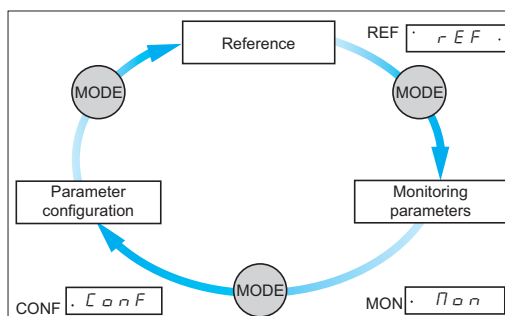

3 operating modes “REF”, “MON” and “CONF”

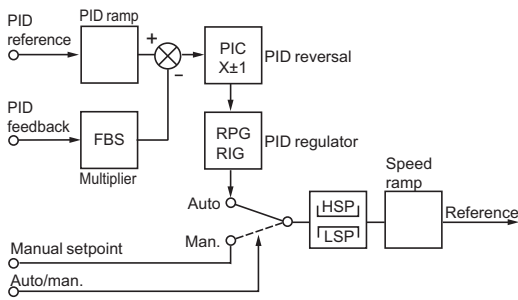

FBS: PID feedback multiplication coefficient
 HSP: High speed
 PIC: Change of direction of PID regulator correction
 LSP: Low speed
 RIG: PID regulator integral gain
 RPG: PID regulator proportional gain

PID regulator

■ **PID regulator**

Used for simple control of a flow rate or a pressure with a sensor which supplies a feedback signal adapted to the drive. This function is suitable for pump and fan applications.

□ **PID reference**

Regulation reference selected from all the possible types:

- Internal reference, representing 0 to 100% of the reference signal. This signal depends on the machine process.
- 2 or 4 preset PID references, adjustable from 0 to 100% of the maximum frequency. This signal depends on the machine process. These references require the use of 1 or 2 logic inputs respectively.
- Manual reference, given by the navigation button.

□ **PID feedback**

- Analog input AI1

□ **Auto/Man.**

- Logic input LI for switching operation to speed reference (Man.) or PID regulation (Auto)

During operation in automatic mode, it is possible to adapt the process feedback, to correct inverse PID and to adjust the proportional and integral gains. The motor speed is limited to between LSP and HSP.

■ **Configuration of the logic input level**

Activates the function assigned to the logic input, whether at high logic level or low logic level, if permitted by the safety rules.

Example: Ramp switching is assigned to logic input LI2; this function is active if LI2 changes to high or low logic level depending on the configuration.

■ **I/O monitoring**

Shows the logic state of inputs LI1, LI2, LI3 and LI4 and outputs LO+ and R1 on the 4-digit display.

■ **Operating direction: forward/reverse**

2-wire control: Forward operation is always assigned to logic input LI1. Reverse operation can be assigned to logic input LI2, LI3 or LI4.

3-wire control: Stop is always assigned to logic input LI1 and forward operation is always assigned to logic input LI2. Reverse operation can be assigned to either logic input LI3 or LI4.

■ **2-wire control**

Controls the direction of operation by means of a stay-put contact (permanent contact, stable logic level 0 or 1, switch).

Run (forward or reverse) and stop commands are controlled by the same logic input.

Enabled by means of 1 or 2 logic inputs (non-reversing or reversing).

See page 22 for the connection diagram.

Three operating modes are possible:

- Detection of the state of the logic inputs
- Detection of a change in state of the logic inputs
- Detection of the state of the logic inputs with forward operation always having priority over reverse

■ **3-wire control**

Controls the operating direction and stopping by means of pulsed contacts (pushbutton-operated temporary contact).

Run (forward or reverse) and stop commands are controlled by 2 different logic inputs.

Enabled by means of 2 or 3 logic inputs (non-reversing or reversing).

See page 22 for the connection diagram.

■ **Acceleration and deceleration ramp times**

This function is used to define acceleration and deceleration ramp times according to the application and the machine dynamics. Each ramp time can be set separately between 0.1 and 999.9 s. Factory-set configuration: 3 s.

■ Ramp time switching

This function is used to switch two acceleration and deceleration ramp times, which can be set separately.

Enabled by means of 1 assignable logic input.

It is suitable for machines with fast speed correction in steady state and high-speed lathes with acceleration and deceleration limiting above certain speeds.

■ Acceleration and deceleration ramp profiles

This function can be used to gradually increase the output frequency starting from a speed reference, following a linear profile or a preset profile.

□ S ramps

The use of S ramps is dedicated to applications involving handling, packaging and passenger transport; this method takes up mechanical backlash and eliminates jolts, and also limits “non-following” of speed during rapid transient operation of high-inertia machines.

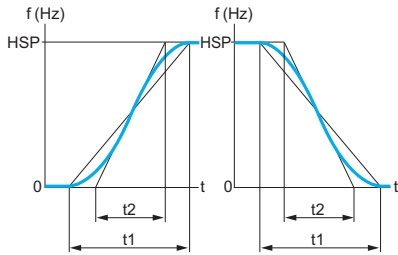

HSP: High speed
 $t1 = k1 \times t2$ ($k1$: fixed rounding coefficient)
 $t2$: Ramp time set

S ramps

□ U ramps

The use of U ramps is dedicated to pump applications such as an installation with centrifugal pump and non-return valve; this method enables valve closing to be controlled more accurately.

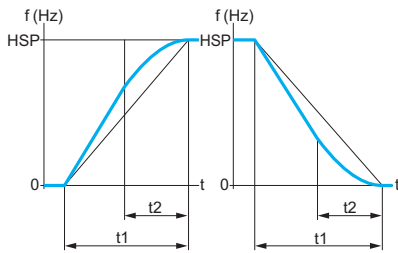

HSP: High speed
 $t1 = k2 \times t2$ ($k2$: fixed rounding coefficient)
 $t2$: Ramp time set

U ramps

Selecting “linear”, “S”, or “U” profiles will affect both the acceleration and deceleration ramps.

■ Automatic adaptation of deceleration ramp

This function is used to increase the deceleration time automatically if the initial setting is too low when the load inertia is taken into account. It prevents the drive locking on an “overvoltage on deceleration” fault.

If a braking unit is connected to the drive, this function must be disabled.

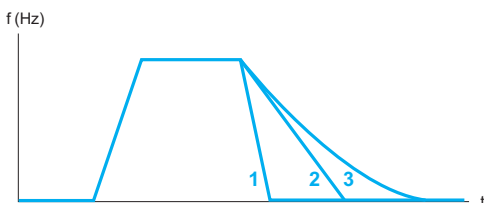

1 Fast stop
 2 Stop on deceleration ramp
 3 Freewheel stop

Stop types

■ Stop types

This is used to define the drive stop mode.

There are three stop types:

- Freewheel stop: When the drive is locked, the motor stops in freewheel mode depending on the application; the motor power supply is cut.
- Stop on deceleration ramp: The motor stops according to the deceleration ramp time which can be fixed or adaptable (see the “Automatic adaptation of deceleration ramp” function).
- Fast stop: Braked stop with an acceptable deceleration ramp time (divided by a coefficient which can be set between 1 and 10) for the drive/motor unit without locking in the event of an “overvoltage on deceleration” fault.

Factory-set configuration: Stop on 3 s deceleration ramp with automatic adaptation.

■ Limiting low speed operating time

The motor is stopped automatically after a period of operation at low speed (LSP). This time can be set between 0.1 and 999 seconds (0 corresponds to an unlimited time).

The motor restarts automatically on a ramp when the reference reappears.

This function is suitable for automatic stops/starts, especially in pump applications.

■ Configuration of analog input AI1

This is used to modify the characteristics, for either voltage or current, of analog input AI1.

Factory-set configuration: 0-5 V (internal power supply).

Other possible values via external power supply: 0-10 V, X-Y mA by programming X and Y with 0 to 20 mA.

■ Automatic restart

This function enables the drive to be restarted automatically after it has locked in fault mode, provided the relevant fault has disappeared and the other operating conditions permit a restart.

This restart is performed by a series of automatic attempts separated by increasingly long waiting periods of 1 s, 5 s, 10 s, then 1 min for subsequent periods.

If the drive has not restarted after 6 minutes, it locks and the procedure is abandoned until the drive is powered down and back up again.

Factory-set configuration: Function inactive.

Restarting is permitted with the following faults:

- Drive thermal overload
- Motor thermal overload
- Line overvoltage
- Overvoltage during deceleration
- Motor overload
- Motor underload
- Output phase loss
- Input phase loss (1)
- Line undervoltage (2)
- Modbus serial link

For this type of fault, the fault relay remains activated if the function has been configured.

This function requires the speed reference and the direction of operation to be maintained, and is only compatible with 2-wire level control.

This function is suitable for machines or installations which are in continuous operation or are not monitored, and where a restart will not endanger equipment or personnel in any way.

■ Automatic catching of a spinning load with speed detection (“catch on the fly”)

Used to restart the motor smoothly after one of the following events:

- Loss of line supply or power off
- Fault reset or automatic restart
- Freewheel stop

Once the event is over, the actual motor speed is detected in order to restart on a ramp at this speed and return to the reference speed. The speed detection time can be up to 1 s (typical value) depending on the initial deviation.

Factory-set configuration: Function inactive.

This function requires the “automatic DC injection braking” function to be disabled.

This function is suitable for machines for which the loss of motor speed is negligible during the power failure (machines with high inertia).

(1) The “input phase loss” fault is only accessible on drives with a three-phase power supply, if monitoring of the fault has been enabled (factory-set configuration: enabled).

(2) The drive will restart as soon as the “undervoltage” fault disappears, regardless of whether the function is active.

■ 2nd current limit

A 2nd current limit can be configured between 0.25 and 1.5 times the nominal drive current and can be used to limit the torque and the rise in motor temperature. Switching between the two current limits is enabled via a logic input or via the Modbus serial link.

■ Automatic DC injection

This function enables standstill DC injection, which can be set between 0 and 1.2 times the value of the nominal drive current (factory-set configuration: 0.7 x motor nominal current), as soon as operation is no longer controlled and the motor speed is zero:

- Either for a period of time, which can be set between 0.1 and 30 s
- Or continuously

Factory-set configuration: Function active with DC injection for 0.5 s. In 3-wire control, DC injection is only active if logic output LI1 is active (assigned to stop).

■ Motor control profiles

Three motor control profiles are available depending on the application requirements:

- Standard (U/F)**: Simple motor control profile maintaining a constant voltage/frequency ratio with an optional low speed setting.

Profile suitable for small conveyors, applications with motors connected in parallel, etc.

- Performance (sensorless flux vector control)**: Profile which can guarantee the level of performance with a motor with the same power or one rating less. This profile can be used to obtain improved dynamic characteristics at low speed.

Profile suitable for running machines, etc.

- Pump/Fan (Kn²)**: Quadratic ratio for obtaining a torque proportional to the square of the speed. This profile can be used to optimize energy consumption according to the load applied to the machine.

Profile suitable for pump regulation, air extraction, etc.

■ Switching frequency, noise reduction

The switching frequency setting between 2 and 16 kHz permits a reduction in the noise generated by the motor for any application requiring a low level of noise.

The switching frequency can be modulated randomly in order to avoid resonance.

This function can be disabled if it causes instability.

Switching the DC voltage at high frequency is useful for supplying the motor with a current wave having little harmonic distortion.

This type of operation increases drive overheating.

Factory-set configuration: Low frequency set at 4 kHz.

■ Frequency jump

Used to pass a mechanical resonance point likely to cause increased noise or risk of mechanical breakdown.

The frequency jump is fixed. It is within ± 1 Hz of the configured resonance point.

■ Jog mode

This can be used for pulse operation with minimum ramp times (0.1 s), a fixed speed reference set at 5 Hz and minimum time of 0.5 s between 2 pulses.

Enabled by 1 logic input and pulses issued by the operating direction command.

This function is suitable for machines with product insertion in manual mode (for example, gradual movement of the mechanism during maintenance operations).

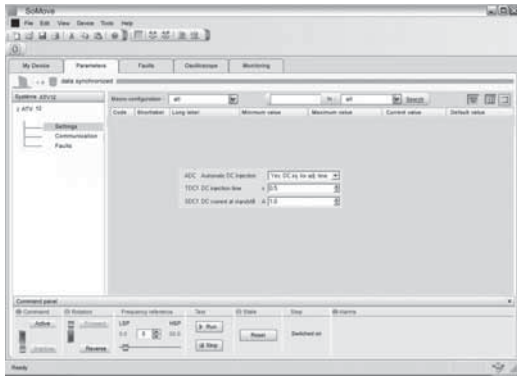

Setting the "DC injection" function with the SoMove setup software



Energy saving with the Pump/Fan profile (Kn²)

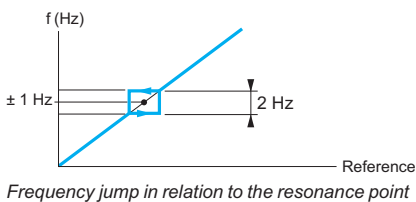

Frequency jump in relation to the resonance point

■ Fault relay, unlocking

The fault relay is energized when the drive is powered up and is not faulty. It opens in the event of a fault or when the drive is powered down.

The drive can be unlocked after a fault in one of the following ways:

- By powering down the drive until the display disappears completely, then powering back up
- By activating the logic input associated with the “fault reset” function, if the function is enabled
- By enabling the “automatic restart” function

■ Drive thermal protection

Thermal protection is integrated in the drive. When the fault is detected, it locks the drive.

Depending on the model, the drive is equipped with a fan.

The drive optimizes management of fan operation in order to reduce the amount of maintenance work and the equipment noise level.

■ Motor thermal protection

The theoretical temperature rise of the motor is continuously calculated to provide thermal protection.

The drive calculates this temperature rise using the following elements:

- The operating frequency
- The current taken by the motor
- The operating time
- The type of motor ventilation (self-cooled or force-cooled)

Thermal protection can be set at anything from 0.2 times the nominal drive current. It must be set to the nominal current indicated on the motor rating plate.

Note: When the power supply is de-energized, the motor thermal state may or may not be stored, depending on the chosen configuration.

■ Monitoring

The display shows the state of the drive or, if selected, one of the following values:

- Frequency reference
- Output frequency applied to the motor
- Motor current
- Line voltage
- Output power
- Motor thermal state
- Drive thermal state
- PID error
- PID feedback
- PID reference
- Motor operating status (stop, forward, reverse, run, acceleration, deceleration, braking, freewheel stop, etc.)

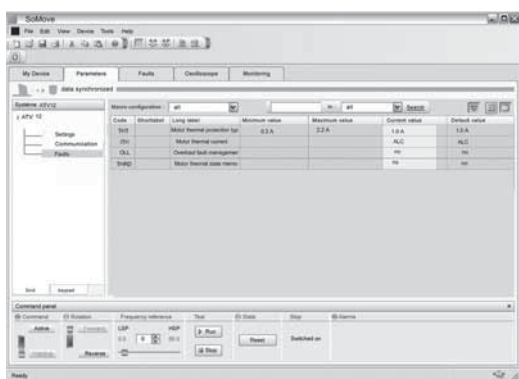

Setting the motor thermal protection with the SoMove setup software

■ Underload detection

This function stops the motor when it is underloaded. The function is active in steady state.

If the current is below an underload threshold for an adjustable period of time, the drive locks in underload fault mode.

The current threshold is adjustable between 20% and 100% of the nominal motor current value.

Hysteresis of 10% is applied to this threshold to confirm the end of underload conditions. The time delay is adjustable up to 100 s. When this parameter is at 0, the function is deactivated.

This function is particularly suitable for protecting pumps during cavitation.

■ Overload detection

This function stops the motor when it is overloaded. The function is active in steady state.

If the motor current is higher than an overload threshold for an adjustable period of time, the drive locks in overload fault mode.

The overload threshold can be set to between 70% and 150% of the nominal motor current.

Hysteresis of 10% is applied to this threshold to confirm the end of overload conditions.

The time delay can be set at anything up to 100 s. When this parameter is at 0, the function is deactivated.

■ Fault acknowledgment

This is used to clear the stored fault and restart the drive if the cause of the fault has disappeared.

The fault is cleared by a transition of the logic input LI which is assigned to this function.

Factory-set configuration: Function inactive.

The restart conditions after a reset are the same as those of a normal power-up.

The following faults can be reset (1): drive thermal overload, motor thermal overload, line overvoltage, overvoltage on deceleration, overspeed, input phase loss (2), etc.

■ Parameter protection by confidential code

This function protects the drive configuration using an access code.

■ Configuration of logic output LO+

Logic output LO+ enables remote signalling of the following information as required:

- Malfunction
- Operation
- Frequency threshold attained
- High speed attained
- Current threshold attained
- Frequency reference attained
- Motor thermal state attained
- 4-20 mA monitoring
- Underload detected
- Overload detected
- Operation of the auxiliary pump with the "Control in single variable mode with auxiliary pump" function

■ Configuration of analog output AO1

Analog output AO1 enables remote signalling of the following information as required:

- Motor current
- Motor frequency
- Ramp output
- PID error
- PID feedback
- PID reference
- Output power
- Motor thermal state
- Drive thermal state

(1) See the complete list of faults in the Altivar 12 Programming Manual, available on our website at www.schneider-electric.com.

(2) The "input phase loss" fault is only accessible on drives with a three-phase power supply, if monitoring of the fault has been enabled (factory-set configuration: enabled).

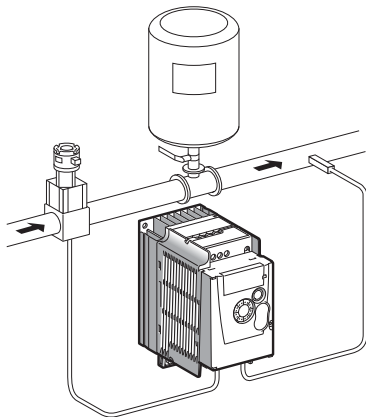

Single variable mode

1

Pump-specific application functions

The main objective here is to control a complete pumping installation using a single Altivar 12 drive by ensuring constant pressure in the system whatever the flow rate. The Altivar 12 has 11 functions designed for water pumping applications:

- Control in single variable mode
- Control in single variable mode with auxiliary pump
- Underload detection
- Overload detection
- Sleep
- Wake-up
- PID feedback supervision
- No-load operation detection
- Quick start
- Automatic restart on underload and overload faults
- PID reference adjustment range for the end user

■ Control in single variable mode

The system is operated using a single variable speed pump (1). A PID regulator controls the variable speed pump. A pressure sensor provides the "PID feedback" information required for system feedback.

■ Control in single variable mode with auxiliary pump

The system is operated using a fixed speed pump, called the auxiliary pump, and a variable speed pump, which is unable to provide the full flow range required on its own (2).

The auxiliary pump's starting and stopping are controlled by logic output LO+ according to the PID regulator output (variable pump frequency reference) with a hysteresis effect as shown in the diagram below (3).

Auxiliary pump starting (4)

If the variable pump control frequency exceeds the threshold (FO_n) for longer than a time period (t_{On}), the auxiliary pump is put into operation (1). The variable pump reference decreases linearly until it reaches the threshold (FO_F).

In order to reduce the effect of overpressure caused by starting of the auxiliary pump, the deceleration time of the variable pump (r_{On}) must be set to the time that the auxiliary pump takes to reach its nominal speed.

Auxiliary pump stopping (5)

Conversely, if the variable pump control frequency falls below the threshold (FO_F) for a period (t_{OF}), the auxiliary pump is stopped (2) and the variable pump reference increases linearly until it reaches the threshold (FO_n). The acceleration time (r_{OF}) is set to the stopping time of the auxiliary pump in order to minimize the effect of underpressure.

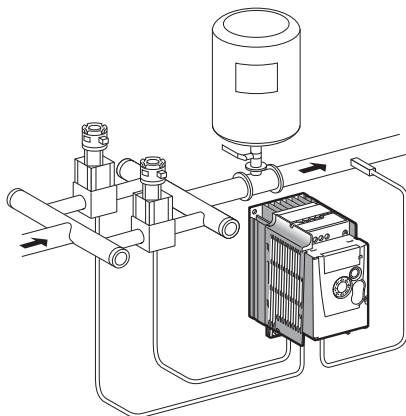

Single variable mode with auxiliary pump

2

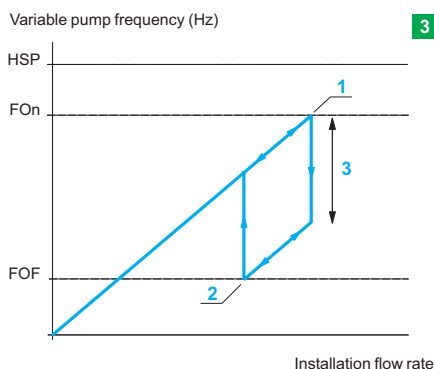

Single variable mode with auxiliary pump: hysteresis

3

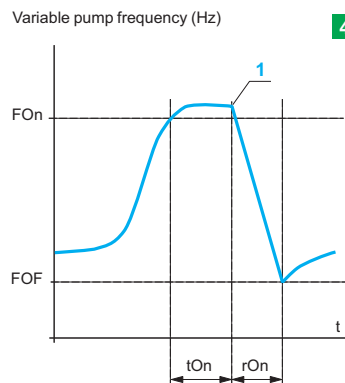

4

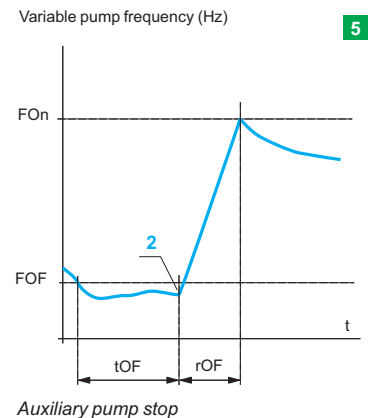

5

1 Auxiliary pump starting

2 Auxiliary pump stopping

3 Frequency range corresponding to the auxiliary pump flow rate

FO_n: Starting frequency of the auxiliary pump

FO_F: Stopping frequency of the auxiliary pump

■ **Underload detection**

See page 34.

■ **Overload detection**

See page 34.

■ **Sleep/Wake-up**

Allows the variable pump to come to a complete stop when the flow rate is considered too low, below an adjustable “sleep threshold” (LSP+ SLE) and time delay (tLS).

When the system is in “sleep” state, if the PID feedback value (showing the pressure downstream of the pump) falls below a “wake up” threshold (UPP), the variable pump is restarted.

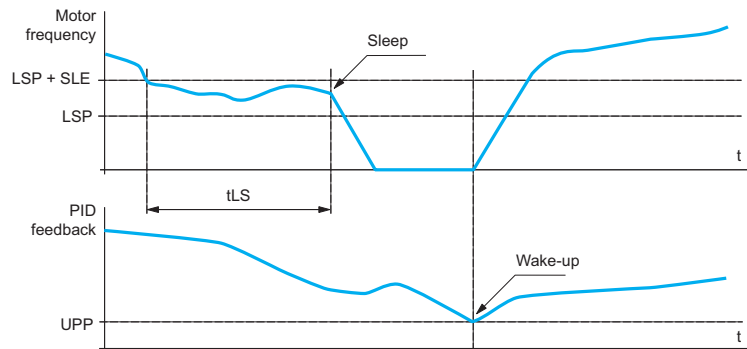

LSP: Low speed
 SLE: Sleep threshold offset
 UPP: Wake-up threshold
 tLS: Sleep threshold operating time

Sleep/Wake-up functions

■ **PID feedback supervision**

Once the variable pump is running at maximum speed and at the same time the PID feedback is lower than the supervision threshold (LPI) at the end of a time delay (tPI), the drive switches to fallback mode. There are two possible scenarios (see graphs below):

- The drive performs a freewheel stop and displays a specific fault code **1**.
 - Configurable fixed speed operation with display of a specific fault code **2**.
- The drive reverts to regulation mode when the PID feedback returns to the supervision threshold (LPI).

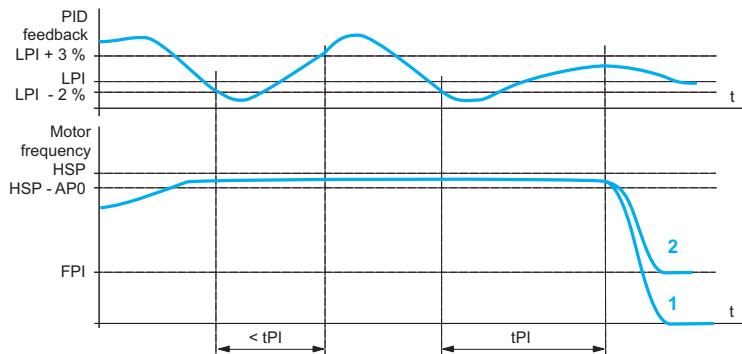

LPI: PID feedback supervision threshold
 HSP: High speed
 FPI: Fallback speed
 APO: Maximum speed detection hysteresis
 tPI: PID feedback supervision function time delay

PID feedback supervision

In single variable mode with auxiliary pump, this function is active when both pumps are operating.

■ **No-load operation detection**

This function is used in applications where zero flow cannot be detected by the sleep function alone. It is active when the auxiliary pump is stopped and the variable pump motor frequency reference is below a configured threshold.

It consists of periodically forcing the motor frequency reference to a low value:

- If the request is still present, it results in an increase in the PID error and the drive reverts to regulation in line with the previous reference.
- If the request is no longer present (zero flow), the PID error will not change, which is characteristic of no-load operation. The variable pump motor is stopped.

■ Quick start

The quick start function aims to overcome the problems associated with the high regulation gains that are necessary at start-up but inappropriate for regulation. The drive accelerates linearly on a ramp (ACC) until its speed reaches the configured quick start threshold (SFS). Once it reaches this threshold (SFS), PID regulation begins.

Variable pump frequency

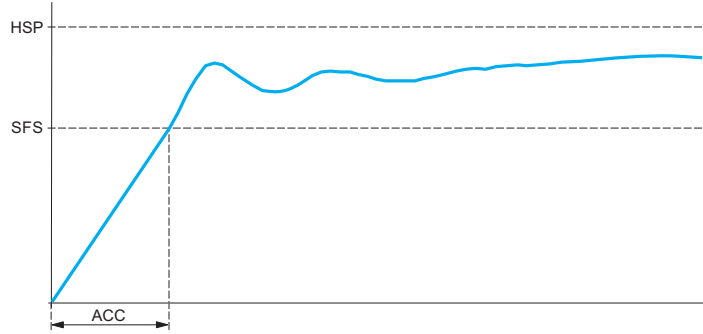

Quick start

HSP: High speed
SFS: Quick start threshold
ACC: Acceleration ramp time

■ Automatic restart on underload and overload faults

Generally, the user can set a parameter to activate automatic restarting after a fault, if the cause(s) of the fault no longer exist(s).

In the case of underload and overload faults, a delay which can be set between 1 s and 6 min 16 s can be used to delay the restart.

■ PID reference adjustment range for the end user

This function allows the end user to adjust the PID regulator reference to increase or reduce the rate of flow.

Adjustment by the user is either by modifying the PID regulator reference parameter, or by manual control of the navigation button, accessible on the drive's front panel.

The installer has access to two PID reference limit parameters, which can be used to define a user's range of action.

Incompatible functions

Application functions can be assigned to the same logic input, in which case one logic input enables a number of functions (for example, direction of operation and ramp time switching).

A check must be carried out to ensure that the functions are compatible:

■ **Direction of operation and 2-wire control:** Forward operation can only be assigned to LI1.

■ **Direction of operation and 3-wire control:** Forward operation can only be assigned to LI2.

■ **Automatic restart:** This function requires the configuration of 2-wire level control. Changing the control type configuration deactivates automatic restarting.

■ **Automatic catching of a spinning load with speed detection:** Incompatible with continuous standstill DC injection. Configuring this function deactivates automatic catching of a spinning load.

Schneider Electric Industries SAS

www.schneider-electric.com

Head Office
35, rue Joseph Monier
F-92500 Rueil-Malmaison
France

The information provided in this documentation contains general descriptions and/or technical characteristics of the performance of the products contained herein. This documentation is not intended as a substitute for and is not to be used for determining suitability or reliability of these products for specific user applications. It is the duty of any such user or integrator to perform the appropriate and complete risk analysis, evaluation and testing of the products with respect to the relevant specific application or use thereof. Neither Schneider Electric nor any of its affiliates or subsidiaries shall be responsible or liable for misuse of the information contained herein.

Design: Schneider Electric
Photos: Schneider Electric
Printed by: