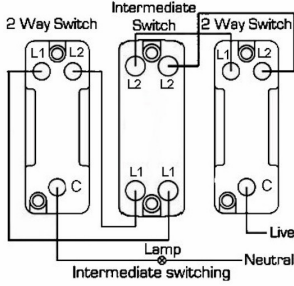
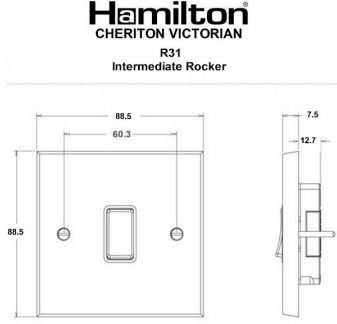

95R31WH-W

Cheriton Victorian Bright Chrome 1 gang 10AX Intermediate Rocker White/White

Item Image	Wiring	Dimensions
		

Primary Range	Cheriton	
Insert Type	1 gang 10AX Intermediate Rocker	
Plate Finish	Cheriton Victorian Box Bright Chrome	
Insert Colour	White/White	
EAN13 Barcode	5017503400317	
Dimensions (Nominal)	Single: Height = 88.5mm Width = 88.5mm Depth = 7.5mm	
Fixing Hole Centres	Box Fixing = 60.3mm Grid Fixing = N/A	
Minimum Wall Box Depth	25mm	
Switched Poles	Single	
Current Rating	10AX	
Voltage	220/250V AC	
Maximum Load	10 Amp inductive	
Mains Frequency	50Hz	
IP Rating	IP2XD	
Contact Gap Minimum	3mm	
Terminal Capacity 1	5 x 1mm ²	
Terminal Capacity 2	4 x 1.5mm ²	
Terminal Capacity 3	1 x 2.5mm ²	
Terminal Capacity 4	1 x 4mm ² Multi-strand	
Terminal Capacity 5	1 x 6mm ²	
Earth Terminal Capacity 1	5 x 1mm ²	
Earth Terminal Capacity 2	4 x 1.5mm ²	
Earth Terminal Capacity 3	3 x 2.5mm ²	
Earth Terminal Capacity 4	1 x 4mm ² Multi-strand	
Earth Terminal Capacity 5	1 x 6mm ²	
Product Class 1	Must be earthed	
Ambient Operating Temperature	-5° to +40°C	
Recommended Location	Internal Use Only	
Maximum Installation Altitude	2000m	
Standard/Approval	BS EN 60669-1	
Patents and Trademarks	Cheriton is a Registered Trade Mark No. 2344779	
All products listed conform to current British or European standard and the product information is correct at the time of going to press.	All accessories are manufactured under an accredited BS EN ISO 9001 : 2015 Quality Management System.	It is the policy of the company to improve products as part of our development programme. Therefore, we reserve the right to alter designs and dimensions without prior notice.
Illustrations and diagrams are reproduced within the limitations of reproduction and printing process and are not binding.	Due to manufacturing processes we cannot guarantee an exact colour match and shadings of certain finishes.	Correct as at 12 October 2018 04:44 PM E&OE