

### Certifications

Fire Resistance : EN 1366-3

Classification : EN 13501-2



EZ-PATH Systems	Ø Cables (mm)	Flexible wall		Rigid wall			Rigid Floor
		≥100mm	≥122mm	≥100mm	≥122mm	≥150mm	≥150mm
<b>1 or 2 x CM250018 (grouted) *</b> <i>1 or 2 x EZD33T (grouted) *</i>	OD ≤ Ø 21	-	-	-	-	EI90 / E120	-
<b>1 x CM250018 + CM250240</b> <i>1 x EZD33T + EZP133CWT</i>	OD ≤ Ø 21	EI60 / E120 *	EI120	EI60 / E120 *	EI120	EI120	-
	OD ≤ Ø 50	-	-	-	-	EI60 / E120	-
<b>2 x CM250018 + CM250120</b> <i>2 x EZD33T + EZP233WT</i>	OD ≤ Ø 21	-	EI120	-	EI120	EI120	-
	OD ≤ Ø 50	-	-	-	-	EI60 / E120	-
<b>3 x CM250018 + CM250130</b> <i>3 x EZD33T + EZP333WT</i>	OD ≤ Ø 21	-	EI120	-	EI120	EI120	-
	OD ≤ Ø 50	-	-	-	-	EI60 / E120	-
<b>4 x CM250018 + CM250140</b> <i>4 x EZD33T + EZP433WT</i>	OD ≤ Ø 21	-	EI120	-	EI120	EI120	-
	OD ≤ Ø 50	-	-	-	-	EI60 / E120	-
<b>7 x CM250018 + CM250170</b> <i>7 x EZD33T + EZP733WT</i>	OD ≤ Ø 21	-	EI120	-	EI120	EI120	-
	OD ≤ Ø 50	-	-	-	-	EI60 / E120	-
<b>1 x CM250018 + CM250220</b> <i>1 x EZD33T + EZP133KT</i>	OD ≤ Ø 21	-	-	-	-	-	EI120

All EZ-Path systems are approved empty up to 100% fill of cables

Please refer to the corresponding Application Data Sheet and Installation Sheet for more additional information about the installation method

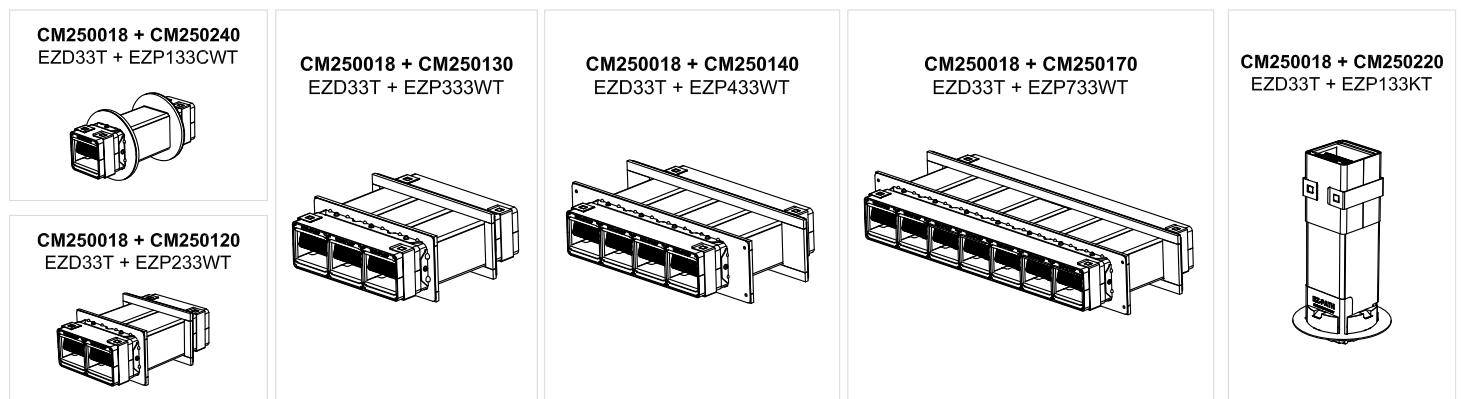
\* Pending CE-Marking certification. These systems are classified per the EN13501-2

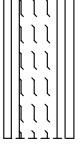

EZ-PATH Systems		Ø Cables (mm)	Flexible wall	Rigid wall		Rigid Floor
			≥122mm	≥122mm	≥150mm	≥150mm
<b>1 x CM250018 + CM250240</b> <i>1 x EZD33T + EZP133CWT</i>	OD ≤ Ø 21	EI120				-
	OD ≤ Ø 50	-	-	-	EI60 / EI120	-
<b>2 x CM250018 + CM250120</b> <i>2 x EZD33T + EZP233WT</i>	OD ≤ Ø 21	EI120	-	-	EI120	-
	OD ≤ Ø 50	-	-	-	EI60 / EI120	-
<b>3 x CM250018 + CM250130</b> <i>3 x EZD33T + EZP333WT</i>	OD ≤ Ø 21	EI120	-	-	EI120	-
	OD ≤ Ø 50	-	-	-	EI60 / EI120	-
<b>4 x CM250018 + CM250140</b> <i>4 x EZD33T + EZP433WT</i>	OD ≤ Ø 21	EI120	-	-	EI120	-
	OD ≤ Ø 50	-	-	-	EI60 / EI120	-
<b>7 x CM250018 + CM250170</b> <i>7 x EZD33T + EZP733WT</i>	OD ≤ Ø 21	EI120	-	-	EI120	-
	OD ≤ Ø 50	-	-	-	EI60 / EI120	-
<b>1 x CM250018 + CM250220</b> <i>1 x EZD33T + EZP133KT</i>	OD ≤ Ø 21	-	-	-	-	EI120

All EZ-Path systems are approved empty up to 100% fill of cables

Please refer to the corresponding Application Data Sheet and Installation Sheet for more additional information about the installation method

