

Technical Data

Wall thickness	Flexible and rigid ≥ 122 mm	Rigid ≥ 150 mm
Cable diameter	OD ≤ Ø21mm	Ø21mm < OD ≤ Ø50mm
Performance	EI120	EI60 / E120
Fire resistance	EN 1366-3 / EN 13501-2	
Cable loading	0% to 100%	
Certification 	ETA - 14/0412	

Opening size	CM250120	155 x 81 mm
	CM250130	230 x 81 mm
	CM250140	305 x 81 mm
	CM250170	540 x 81 mm

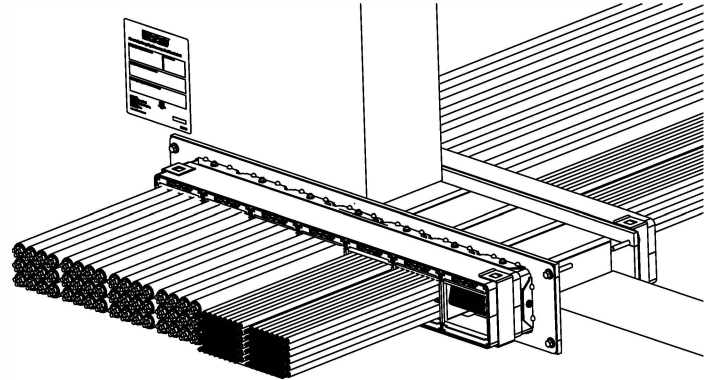

CM250018 / EZD33T
76 x 76 x 267 mm

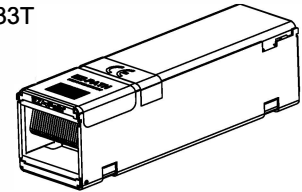

CM250120 + CM250018 (2x)
EZP233WT + EZD33T (2x)

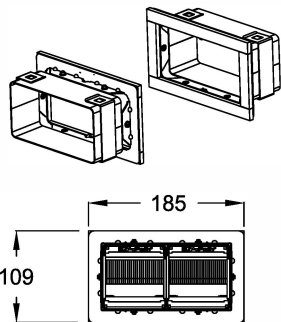

CM250130 + CM250018 (3x)
EZP333WT + EZD33T (3x)

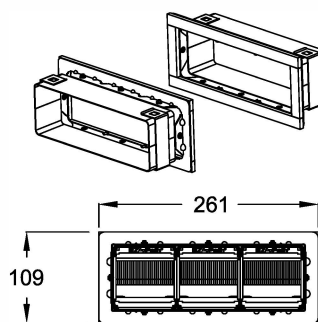

CM250140 + CM250018 (4x)
EZP433WT + EZD33T (4x)

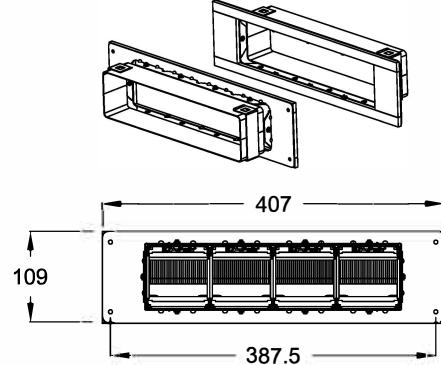

CM250170 + CM250018 (7x)
EZP733WT + EZD33T (7x)

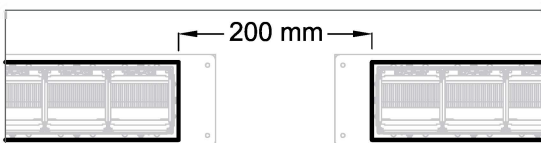
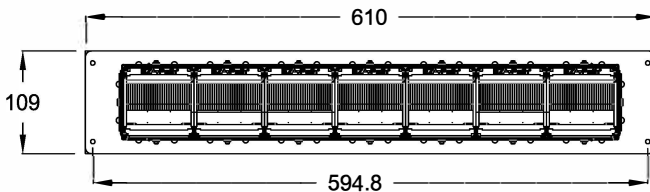

Minimum distance between penetration seals

Not at scale. Units in millimeters
Please refer to the Installation Sheet

