

FLOOR AND PERIMETER SYSTEMS

PRODUCT TECHNICAL GUIDE



Global strength

built on local knowledge

Legrand is the global specialist in electrical and digital building infrastructures. Innovation is the driving force behind its development. With an increasing investment in research and development (circa 5% of sales) and more than 4,000 active patents, the Legrand Group is focused on maintaining a high rate of new product launches that present innovative solutions to the market.

COMPLETE CABLE MANAGEMENT SOLUTIONS

Using its global strength and market leading position, Legrand has developed a complete range of cable management solutions, including:

- Swifts cable ladder
- Swifts cable tray
- Salamandre distribution trunking
- Salamandre lighting trunking
- Cablofil steel wire cable tray
- Cablofil PVC tray
- Floor systems - including underfloor trunking, floor boxes, grommets and the Soluflex cavity floor system





PRODUCT SELECTION

STEEL PERIMETER TRUNKING SYSTEMS	
Selection chart	4
110 x 63mm	6
130 x 63mm	8
170 x 63mm	10
170A x 63mm (with offset opening)	12
Pedestal units	14
Wiring accessories	15

3 SIMPLE STEPS... to choose the right solution	20
--	----

CAVITY FLOOR SERVICE OUTLET BOXES

Selection chart	24
Cavity floor service outlet boxes	26
Outlet plates, lids and trims	27
Cavity floor grommets	30
IP 66 floor boxes	31

SOLUFLEX CAVITY FLOOR SYSTEM

Selection chart	34
Ultra low cavity floor system	36

COMMERCIAL FLOOR TRUNKING SYSTEMS

Flush floor trunking	44
Shallow flush floor trunking	45
Underfloor duct	46
Flush lid floor trunking	51
Recessed lid floor trunking	51

SCREED FLOOR SERVICE OUTLET BOXES

Selection chart	48
Outlet plates, lids and trims	50

INDUSTRIAL FLOOR TRUNKING SYSTEMS

Chequer plate floor trunking	52
------------------------------	----

TECHNICAL SPECIFICATIONS

Pedestal systems	14
Steel perimeter trunking	16
Cavity floor boxes	28
Grommets	31
Soluflex	38
Floor trunking	52

STEEL PERIMETER TRUNKING

Legrand's steel perimeter trunking system provides the end user with a safe and stylish solution and the installer with an easy and quick to fit system. Being steel, the trunking is tough enough for high traffic environments such as schools, hospitals and laboratories.

Steel perimeter trunking from Legrand... flexible, fast fit and safe

- Available in heights of 110, 130 and 170mm, including a 170mm skirting option with offset opening
- Screwless - no visible screws when installed
- Earthing cams earth the system during assembly
- Up to 4 compartments can be easily configured on site
- Powder coating is low smoke zero halogen
- Available in other finish styles - unpainted, any RAL colour

simple, reliable
power and data
distribution





Steel back boxes are compatible with British Standard wiring accessories and improve EMC (electromagnetic compatibility)

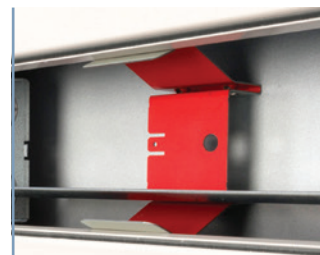

The universal snapper clip allows compartments to be configured on site and the steel divider improves EMC

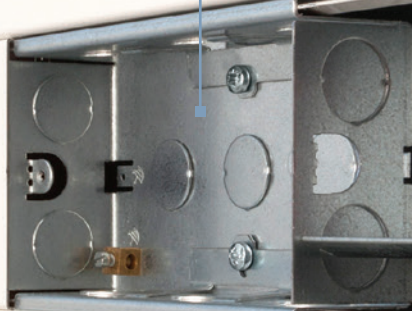



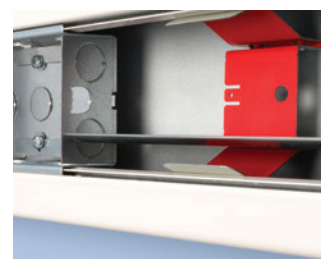



A range of wiring accessories can be added to the trunking, including Legrand's Synergy and Arteor ranges







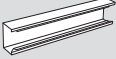

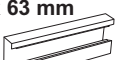



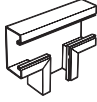
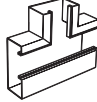

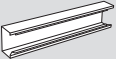

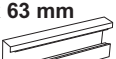

The rolled edge on the trunking opening and divider reduces the risk of injury or damage to cables when installing the trunking

steel perimeter trunking selection chart

110 x 63 mm / 130 x 63 mm / 170 x 63 mm / 170A x 63 mm

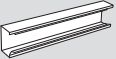
Type	Trunking body 	Lid 	Accessory spacer lid 	Couplers ¹ (Supplied in pairs) 
	Length 3 m	Length 1-5 m	Length 100 mm	
110 x 63 mm 	MP351233	MP351230	MP351220	MP351523
130 x 63 mm 	MP351235	MP351230	MP351220	MP351525
170 x 63 mm 	MP351236	MP351230	MP351220	MP351526
170A x 63 mm 	MP351237	MP351230	MP351220	MP351527

Type	Flat bend body rising 	Flat bend body descending 	Tee body ⁴ 	Tee body rising ⁴ 	Tee cover strap 
110 x 63 mm 	-	-	MP351393	-	MP351563
130 x 63 mm 	-	-	MP351395	-	MP351565
170 x 63 mm 	-	-	MP351396	-	MP351566
170A x 63 mm 	MP351337	MP351367	-	MP351397	MP351567 ² MP351597 ³

Type	Riser trunking lid 	Earthing wire 	Universal snapper clip ¹ 	Divider ¹ 	Base divider ¹ 	Base divider fixing bracket ¹ 
				1 m	2 m	
				Regular power and data separation	Additional partition for the base	
110 x 63 mm 	MP351439	MP351499	MP351319	MP351189	-	-
130 x 63 mm 	MP351439	MP351499	MP351319	MP351189	MP351279	MP351299
170 x 63 mm 	MP351439	MP351499	MP351319	MP351189	MP351289	MP351309
170A x 63 mm 	MP351439	MP351499	MP351319	MP351189	MP351289	MP351309

1 : Internal components supplied unpainted 2 : Rising to 170 mm wide trunking

3 : Rising to 130 mm wide trunking 4 : Crossover available on request, please contact us on +44 (0)370 608 9020

Universal internal/external bend lid 90° +/- 5° 	Internal bend cover straps 135°- 180° 	Internal bend body 	External bend body 	External bend lid 	Flat bend body 	Flat bend lid 
MP351173	MP351203	MP351273	MP351303	MP351240	MP351333	MP351260
MP351175	MP351205	MP351275	MP351305	MP351240	MP351335	MP351260
MP351176	MP351206	MP351276	MP351306	MP351240	MP351336	MP351260
MP351177	MP351207	MP351277	MP351307	MP351240	-	MP351260
End cap 	Cover strap 	Tolerance cover strap 	Wall flange plate 	Wall flange closing plate 	Support flange 	Riser trunking body¹ (170 x 38 mm) 
MP351043	MP351103	MP351073	MP351483	MP351513	MP351453	MP351409
MP351045	MP351105	MP351075	MP351485	MP351515	MP351455	MP351409
MP351046	MP351106	MP351076	MP351486	MP351516	MP351456	MP351409
MP351046	MP351107	MP351077	MP351486	MP351516	MP351456	MP351409
Internal lid support¹ 	Internal bend lid 	End support bracket¹ 	Tee support bracket¹ 	Acoustic insulation block 	Cutting support block 	Touch-up paint 
IP 40 / IK 07						
MP351469	MP351250	MP351449	MP351459	MP351389	MP351533	MP351029
MP351469	MP351250	MP351449	MP351459	MP351389	MP351535	MP351029
MP351469	MP351250	MP351449	MP351459	MP351399	MP351536	MP351029
MP351469	MP351250	MP351449	MP351459	MP351399	MP351536	MP351029

steel perimeter trunking system – 110 x 63 mm

for dado applications

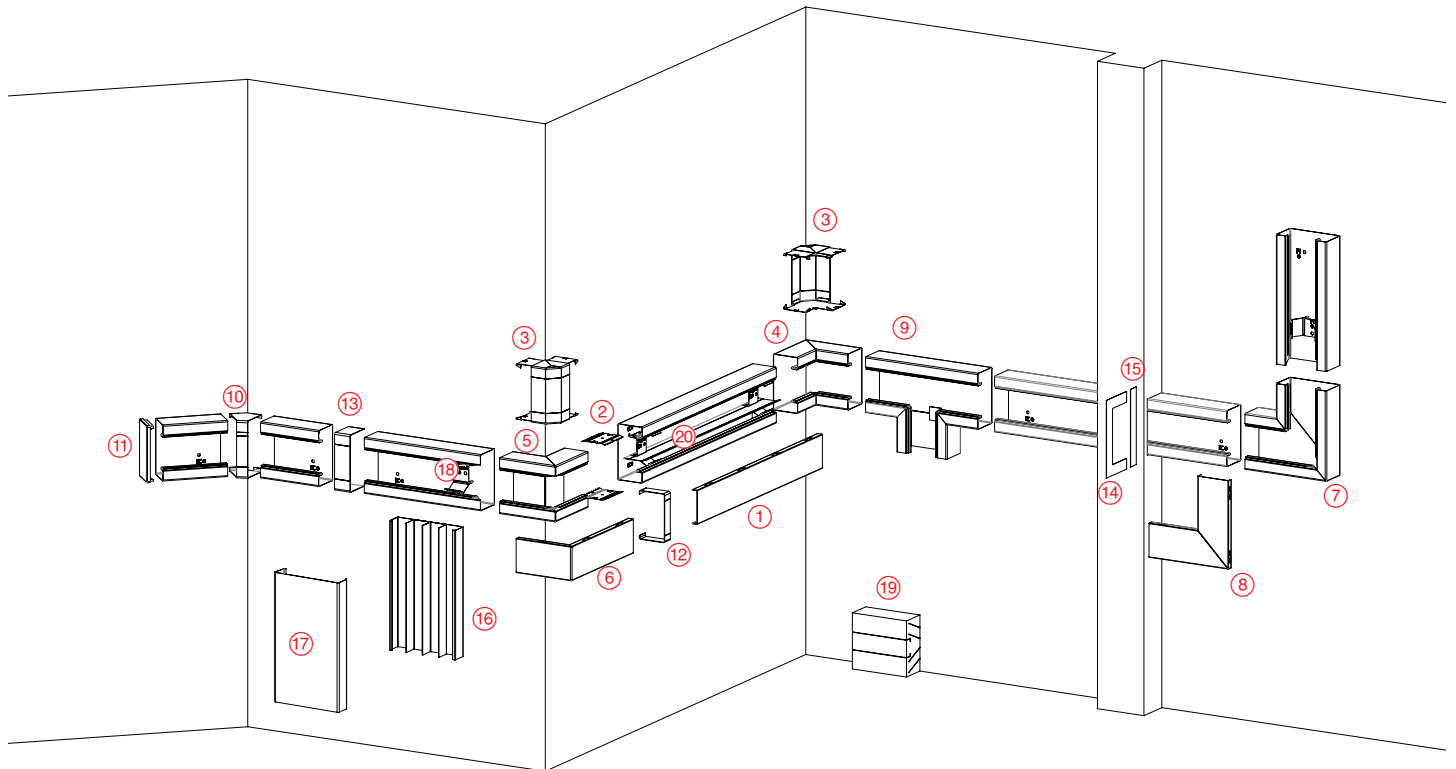

Selection charts **p. 4-5**
 Dimensions and technical information **p. 16-19**
 Installation material **p. 19**

Manufactured to BS EN 50085-2-1 : 2006
 Manufactured using pre-galvanised steel to BS EN 10346 : 2009 grade DX51D
 Powder coated to RAL 9010
 Trunking can be configured with 2 or 3 compartments with the option of a base divider giving the potential of 4 compartments
 Push-fit covers are designed to give excellent earth continuity without extra components

Pack	Cat. Nos.	Trunking body		Pack	Cat. Nos.	Fittings (continued)	
1	MP351233	Length – 3 m		1	MP351273	Internal bend body ④ Requires 2 pairs of couplers Cat. No. MP351523 (opposite)	
1	MP351230	Lid ① Length – 1.5 m		1	MP351303	External bend body ⑤ Requires 2 pairs of couplers Cat. No. MP351523 (opposite)	
1	MP351220	Length – 100 mm For use as a spacer in between wiring accessories		1	MP351240	External bend lid ⑥	
10	MP351523	Fittings Couplers ② Supplied in pairs Zinc plated		1	MP351333	Flat bend body ⑦ Requires 2 pairs of couplers Cat. No. MP351523 (opposite)	
1	MP351173	Universal internal/external bend lid 90° +/- 5° ③ Complete with integral coupler		2	MP351260	Flat bend lid ⑧	
1	MP351203	Internal bend cover straps 135°- 180° ⑩ Complete with adjustable coupler		1	MP351393	Tee body ⑨ Requires 3 pairs of couplers Cat. No. MP351523 (opposite) Crossovers available on request, contact us on +44 (0) 370 608 9020	
				1	MP351563	Tee cover strap Rising to 110 mm trunking	

1: Internal components supplied unpainted

steel perimeter trunking system – 110 x 63 mm

for dado applications (continued)



MP351233



MP351333



MP351393



MP351043



MP351103



MP351073

Selection charts **p. 4-5**
Dimensions and technical information **p. 16-19**
Installation material **p. 19**

Pack	Cat. Nos.	Fittings (continued)
1	MP351043	End cap ⁽¹¹⁾
10	MP351103	Cover strap ⁽¹²⁾ Width – 25 mm
8	MP351073	Tolerance cover strap ⁽¹³⁾ Width – 40 mm
1	MP351483	Wall flange plate ⁽¹⁴⁾
1	MP351513	Wall flange closing plate ⁽¹⁵⁾
1	MP351453	Support flange
1	MP351409	Riser trunking body 170 x 38 mm ⁽¹⁶⁾ Pre-galvanised Length – 2 m
1	MP351439	Riser trunking lid ⁽¹⁷⁾ Friction fit Length – 1 m
1	MP351499	Earthing wire Length – 300 mm



Pack	Cat. Nos.	Regular power and data separation
20	MP351319	Universal snapper clip ⁽¹⁸⁾ Multifunction clip for fitting of divider, separation of cables (50 mm) and additional support of lid
10	MP351189	Divider ⁽²⁰⁾ Requires universal snapper clip Cat. No. MP351319 Length – 1 m
1	MP351469	Additional products IP 40 / IK 07 Internal lid support ¹ Fits inside lid joints to achieve IP 40
1	MP351250	Internal bend lid To achieve IP 40 on internal bends
5	MP351449	End support bracket ¹ Provides additional lid support at end of run Use to achieve IK 07
5	MP351459	Tee support bracket ¹ Fits inside lid joints to achieve IP 40 at tee junction
1	MP351389	Accessories Acoustic insulation block ⁽¹⁹⁾ For use when trunking passes through walls to reduce noise travel Self extinguishing plastic Acoustic tested according to NEN 5077/ISO 140/4
1	MP351533	Cutting support block Holds trunking in position and guides saw for a straight cut Steel
1	MP351029	Touch-up paint Contents – 10 ml

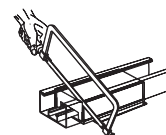
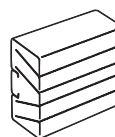
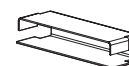
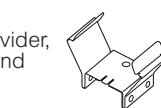

1: Internal components supplied unpainted

steel perimeter trunking system – 130 x 63 mm

for dado applications

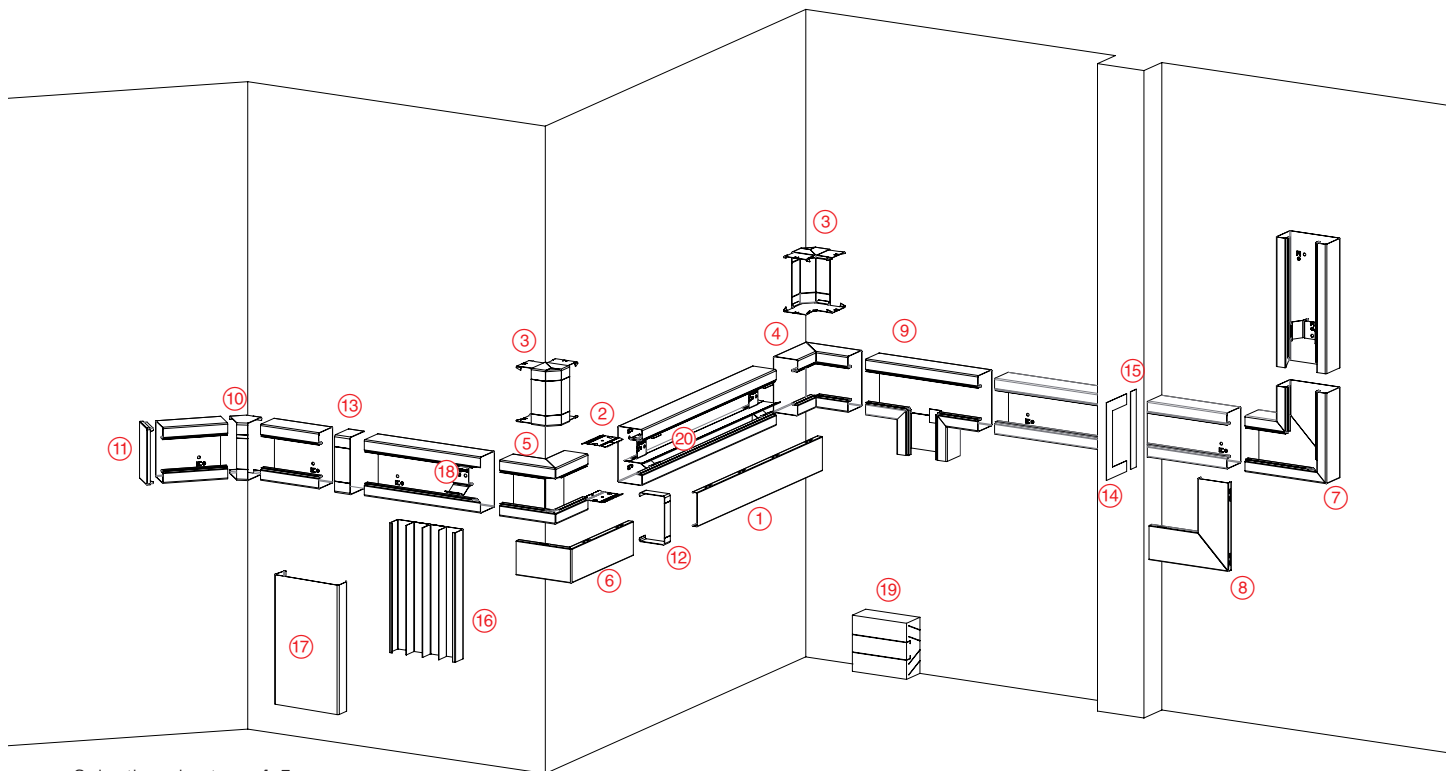

Selection charts **p. 4-5**
 Dimensions and technical information **p. 16-19**
 Installation material **p. 19**

Manufactured to BS EN 50085-2-1 : 2006
 Manufactured using pre-galvanised steel to BS EN 10346 : 2009 grade DX51D
 Powder coated to RAL 9010
 Trunking can be configured with 2 or 3 compartments with the option of a base divider giving the potential of 4 compartments
 Push-fit covers are designed to give excellent earth continuity without extra components

Pack	Cat. Nos.	Trunking body	Pack	Cat. Nos.	Fittings (continued)
1	MP351235	Length – 3 m	1	MP351275	Internal bend body ④ Requires 2 pairs of couplers Cat. No. MP351525 (opposite)
1	MP351230	Lid ① Length – 1.5 m	1	MP351305	External bend body ⑤ Requires 2 pairs of couplers Cat. No. MP351525 (opposite)
1	MP351220	Length – 100 mm For use as a spacer in between wiring accessories	1	MP351240	External bend lid ⑥
10	MP351525	Fittings Couplers ② Supplied in pairs Zinc plated	1	MP351335	Flat bend body ⑦ Requires 2 pairs of couplers Cat. No. MP351525 (opposite)
1	MP351175	Universal internal/external bend lid 90° +/- 5° ③ Complete with integral coupler	2	MP351260	Flat bend lid ⑧
1	MP351205	Internal bend cover straps 135°- 180° ⑩ Complete with adjustable coupler	1	MP351395	Tee body ⑨ Requires 3 pairs of couplers Cat. No. MP351525 (opposite) Crossovers available on request, contact us on +44 (0) 370 608 9020
			1	MP351565	Tee cover strap Rising to 130 mm trunking

1: Internal components supplied unpainted

steel perimeter trunking system – 130 x 63 mm

for dado applications (continued)



MP351235

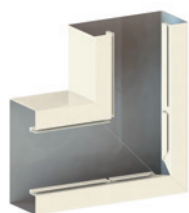

MP351335



MP351395



MP351045



MP351105



MP351075

Selection charts **p. 4-5**
Dimensions and technical information **p. 16-19**
Installation material **p. 19**

Pack	Cat. Nos.	Fittings (continued)
1	MP351045	End cap ⁽¹¹⁾
10	MP351105	Cover strap ⁽¹²⁾ Width – 25 mm
8	MP351075	Tolerance cover strap ⁽¹³⁾ Width – 40 mm
1	MP351485	Wall flange plate ⁽¹⁴⁾
1	MP351515	Wall flange closing plate ⁽¹⁵⁾
1	MP351455	Support flange
1	MP351409	Riser trunking body 170 x 38 mm ⁽¹⁶⁾ Pre-galvanised Length – 2 m
1	MP351439	Riser trunking lid ⁽¹⁷⁾ Friction fit Length – 1 m
1	MP351499	Earthing wire Length – 300 mm

Pack	Cat. Nos.	Regular power and data separation
20	MP351319	Universal snapper clip ⁽¹⁸⁾ Multifunction clip for fitting of divider, separation of cables (50 mm) and additional support of lid
10	MP351189	Divider ⁽²⁰⁾ Requires universal snapper clip Cat. No. MP351319 Length – 1 m
10	MP351279	Additional partition for the base Base divider ⁽¹⁾ Fixing bracket required (below) Length – 2 m Height – 22 mm, for type 130
10	MP351299	Base divider fixing bracket ⁽¹⁾ Height – 21 mm, for type 130 1 per metre required
1	MP351469	Additional products IP 40 / IK 07 Internal lid support ⁽¹⁾ Fits inside lid joints to achieve IP 40
1	MP351250	Internal bend lid To achieve IP 40 on internal bends
5	MP351449	End support bracket ⁽¹⁾ Provides additional lid support at end of run Use to achieve IK 07
5	MP351459	Tee support bracket ⁽¹⁾ Fits inside lid joints to achieve IP 40 at tee junction
1	MP351389	Accessories Acoustic insulation block ⁽¹⁹⁾ For use when trunking passes through walls to reduce noise travel Self extinguishing plastic Acoustic tested according to NEN 5077/ISO 140/4
1	MP351535	Cutting support block Holds trunking in position and guides saw for a straight cut Steel
1	MP351029	Touch-up paint Contents – 10 ml

1: Internal components supplied unpainted

steel perimeter trunking system – 170 x 63 mm

for dado or skirting applications

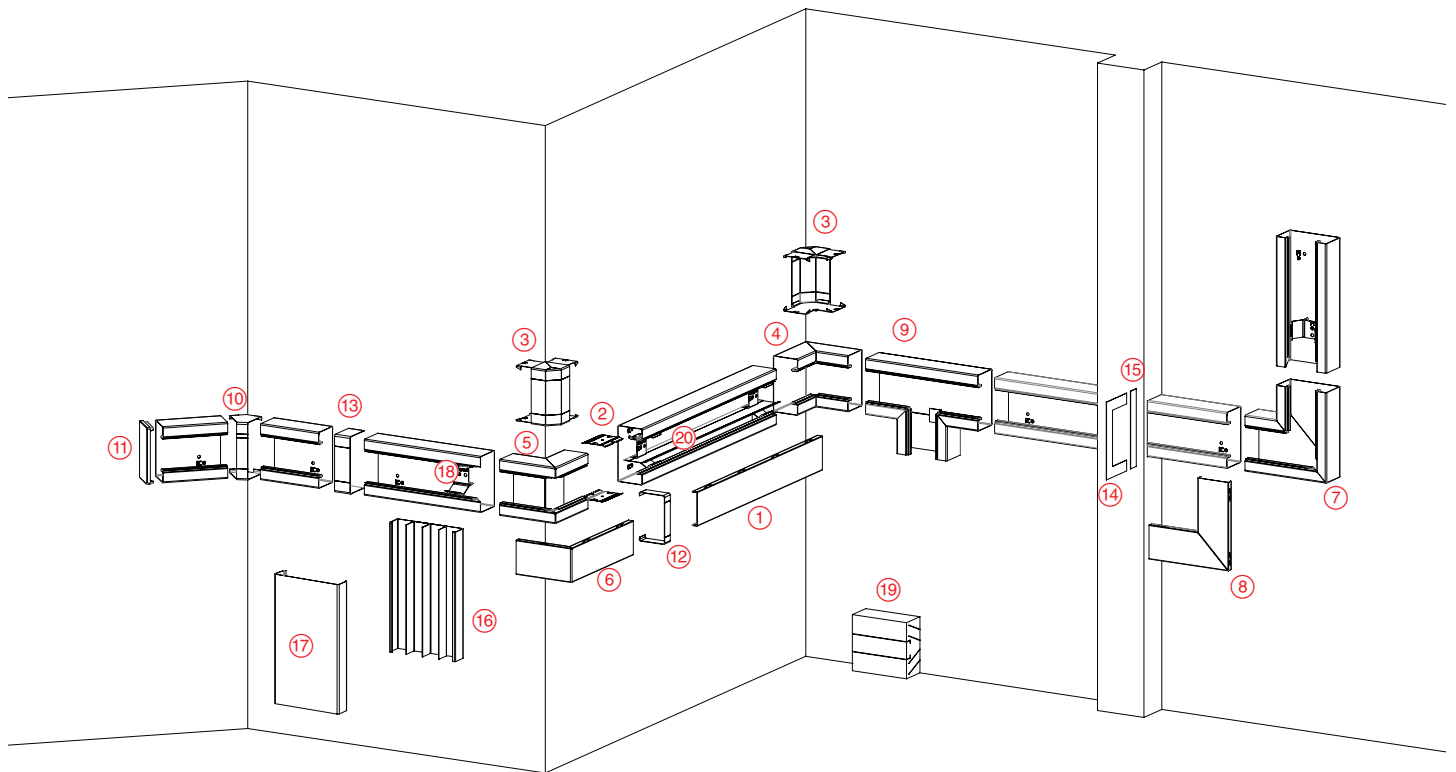

Selection charts **p. 4-5**
 Dimensions and technical information **p. 16-19**
 Installation material **p. 19**

Manufactured to BS EN 50085-2-1 : 2006
 Manufactured using pre-galvanised steel to BS EN 10346 : 2009 grade DX51D
 Powder coated to RAL 9010
 Trunking can be configured with 2 or 3 compartments with the option of a base divider giving the potential of 4 compartments
 Push-fit covers are designed to give excellent earth continuity without extra components

Pack	Cat. Nos.	Trunking body		Pack	Cat. Nos.	Fittings (continued)	
1	MP351236	Length – 3 m		1	MP351276	Internal bend body ④ Requires 2 pairs of couplers Cat. No. MP351526 (opposite)	
1	MP351230	Lid ① Length – 1.5 m		1	MP351306	External bend body ⑤ Requires 2 pairs of couplers Cat. No. MP351526 (opposite)	
1	MP351220	Length – 100 mm For use as a spacer in between wiring accessories		1	MP351240	External bend lid ⑥	
10	MP351526	Fittings Couplers¹ ② Supplied in pairs Zinc plated		1	MP351336	Flat bend body ⑦ Requires 2 pairs of couplers Cat. No. MP351526 (opposite)	
1	MP351176	Universal internal/external bend lid 90° +/- 5° ③ Complete with integral coupler		2	MP351260	Flat bend lid ⑧	
1	MP351206	Internal bend cover straps 135°- 180° ⑩ Complete with adjustable coupler		1	MP351396	Tee body ⑨ Requires 3 pairs of couplers Cat. No. MP351526 (opposite) Crossovers available on request, contact us on +44 (0) 370 608 9020	
				1	MP351566	Tee cover strap Rising to 170 mm trunking	

1: Internal components supplied unpainted

steel perimeter trunking system – 170 x 63 mm

for dado or skirting applications (continued)

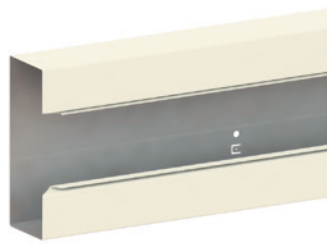

MP351236



MP351526



MP351306



MP351046



MP351106



MP351076

Selection charts **p. 4-5**
Dimensions and technical information **p. 16-19**
Installation material **p. 19**

Pack	Cat. Nos.	Fittings (continued)
1	MP351046	End cap ⁽¹¹⁾
10	MP351106	Cover strap ⁽¹²⁾ Width – 25 mm
8	MP351076	Tolerance cover strap ⁽¹³⁾ Width – 40 mm
1	MP351486	Wall flange plate ⁽¹⁴⁾
1	MP351516	Wall flange closing plate ⁽¹⁵⁾
1	MP351456	Support flange
1	MP351409	Riser trunking body 170 x 38 mm ⁽¹⁶⁾ Pre-galvanised Length – 2 m
1	MP351439	Riser trunking lid ⁽¹⁷⁾ Friction fit Length – 1 m
1	MP351499	Earthing wire Length – 300 mm

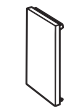

20

MP351319

Regular power and data separation

Universal snapper clip

⁽¹⁸⁾

Multifunction clip for fitting of divider, separation of cables (50 mm) and additional support of lid

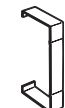
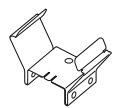

10

MP351189

Divider

⁽²⁰⁾

Requires universal snapper clip
Cat. No. MP351319
Length – 1 m

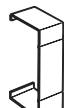

10

MP351289

Additional partition for the base

Base divider

⁽¹⁾

Fixing bracket required (below)
Length – 2 m
Height – 45 mm, for type 170/170A

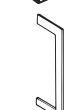

10

MP351309

Base divider fixing bracket

⁽¹⁾

Height – 44 mm, for type 170
1 per metre required



1

MP351469

Additional products IP 40 / IK 07

Internal lid support

⁽¹⁾

Fits inside lid joints to achieve IP 40

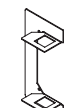

1

MP351250

Internal bend lid

To achieve IP 40 on internal bends



5

MP351449

End support bracket

⁽¹⁾

Provides additional lid support at end of run
Use to achieve IK 07

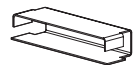

5

MP351459

Tee support bracket

⁽¹⁾

Fits inside lid joints to achieve IP 40 at tee junction

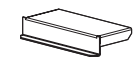

Accessories

Acoustic insulation block

⁽¹⁹⁾

For use when trunking passes through walls to reduce noise travel
Self extinguishing plastic
Acoustic tested according to NEN 5077/ISO 140/4

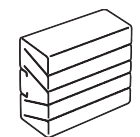

1

MP351536

Cutting support block

Holds trunking in position and guides saw for a straight cut
Steel

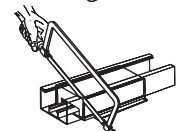

Touch-up paint

Contents – 10 ml



1: Internal components supplied unpainted

steel perimeter trunking system – 170A x 63 mm (with offset opening)

for dado or skirting applications

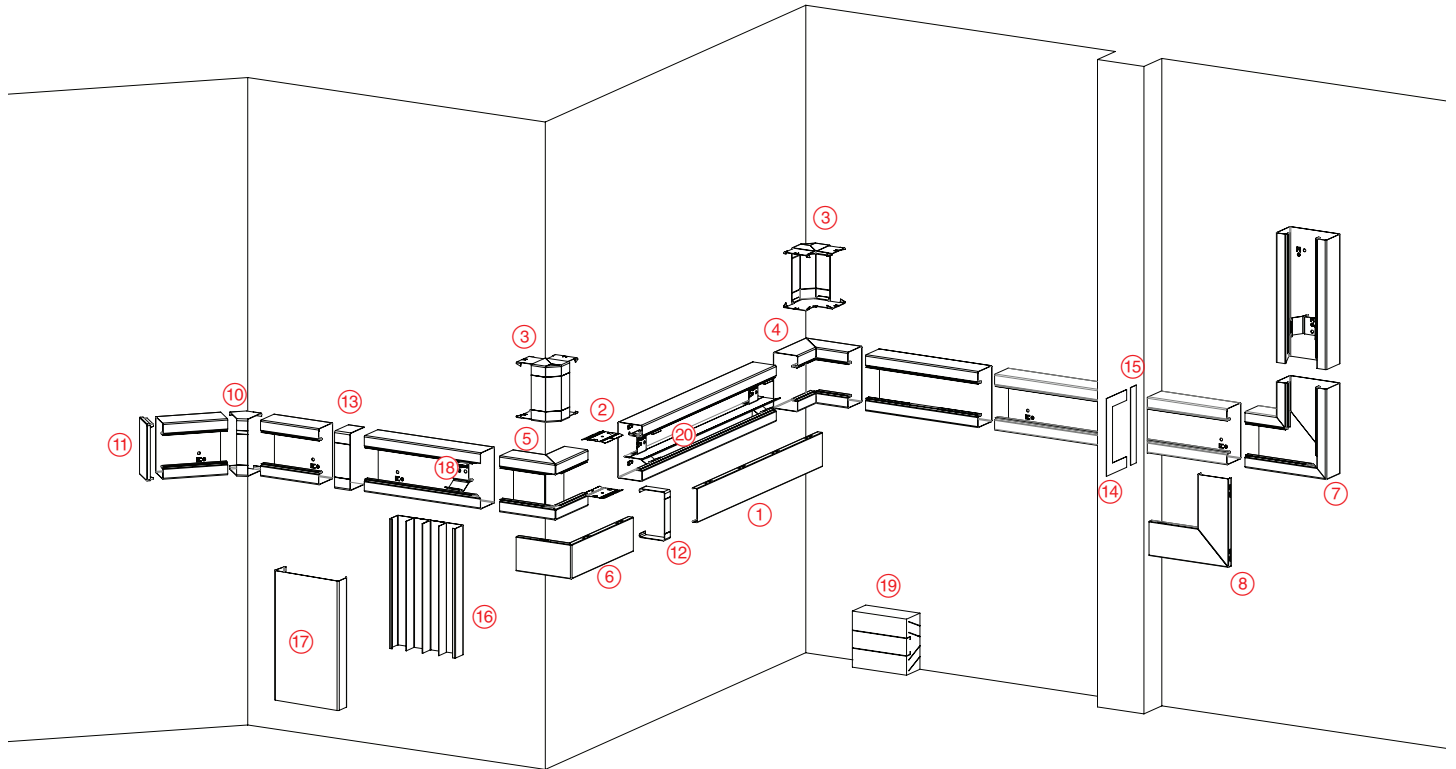

Selection charts **p. 4-5**
 Dimensions and technical information **p. 16-19**
 Installation material **p. 19**

Manufactured to BS EN 50085-2-1 : 2006
 Manufactured using pre-galvanised steel to BS EN 10346 : 2009 grade DX51D
 Powder coated to RAL 9010
 Trunking can be configured with 2 or 3 compartments with the option of a base divider giving the potential of 4 compartments
 Push-fit covers are designed to give excellent earth continuity without extra components

Pack	Cat. Nos.	Trunking body	Pack	Cat. Nos.	Fittings (continued)
1	MP351237	Length – 3 m With offset opening for easier plug insertion and removal in skirting applications	1	MP351277	Internal bend body ④ Requires 2 pairs of couplers Cat. No. MP351527 (opposite)
1	MP351230	Lid ① Length – 1.5 m	1	MP351307	External bend body ⑤ Requires 2 pairs of couplers Cat. No. MP351527 (opposite)
1	MP351220	Length – 100 mm For use as a spacer in between wiring accessories	1	MP351240	External bend lid ⑥
10	MP351527	Fittings Couplers¹ ② Supplied in pairs Zinc plated	1	MP351337	Flat bend body rising ⑦ Requires 2 pairs of couplers Cat. No. MP351527 (opposite)
1	MP351177	Universal internal/external bend lid 90° +/- 5° ③ Complete with integral coupler	1	MP351367	Flat bend body descending Requires 2 pairs of couplers Cat. No. MP351527 (opposite)
1	MP351207	Internal bend cover straps 135°- 180° ⑩ Complete with adjustable coupler	2	MP351260	Flat bend lid ⑧ Suitable for rising or descending bend body
			1	MP351397	Tee body rising Requires 2 pairs of couplers Cat. No. MP351527 (opposite) Rising to 130 mm trunking Crossovers available on request, contact us on +44 (0) 370 608 9020

1: Internal components supplied unpainted

steel perimeter trunking system – 170A x 63 mm (with offset opening)

for dado or skirting applications (continued)



MP351237



MP351527



MP351046



MP351107



MP351077



Selection charts **p. 4-5**
Dimensions and technical information **p. 16-19**
Installation material **p. 19**

Pack	Cat. Nos.	Fittings (continued)	Pack	Cat. Nos.	Regular power and data separation
1	MP351567	Tee cover strap For use when – Rising to 170mm trunking Rising to 130mm trunking	20	MP351319	Universal snapper clip¹ 18 Multifunction clip for fitting of divider, separation of cables (50 mm) and additional support of lid
1	MP351597		10	MP351189	
1	MP351046		8	MP351077	Additional partition for the base Base divider¹ Fixing bracket required (below) Length – 2 m Height – 45 mm, for type 170/170A Base divider fixing bracket¹ Height = 44 mm, for type 170/170A 1 per metre required
10	MP351107	Cover strap 12 Width – 25 mm Tolerance cover strap 13 Width – 40 mm	1	MP351486	Additional products IP 40 / IK 07 Internal lid support¹ Fits inside lid joints to achieve IP 40 Internal bend lid To achieve IP 40 on internal bends End support bracket¹ Provides additional lid support at end of run Use to achieve IK 07 Tee support bracket¹ Fits inside lid joints to achieve IP 40 at tee junction
1	MP351486	Wall flange plate 14 Wall flange closing plate 15 Support flange	1	MP351250	Accessories Acoustic insulation block 19 For use when trunking passes through walls to reduce noise travel Self extinguishing plastic Acoustic tested according to NEN 5077/ISO 140/4 Cutting support block Holds trunking in position and guides saw for a straight cut Steel Touch-up paint Contents – 10 ml
1	MP351456	Riser trunking body 170 x 38 mm¹ 16 Pre-galvanised Length – 2 m Riser trunking lid 17 Friction fit Length – 1.0 m Earthing wire Length – 300 mm	1	MP351449	
1	MP351409		5	MP351459	
1	MP351439		1	MP351399	
1	MP351499		1	MP351536	
			1	MP351029	

1: Internal components supplied unpainted

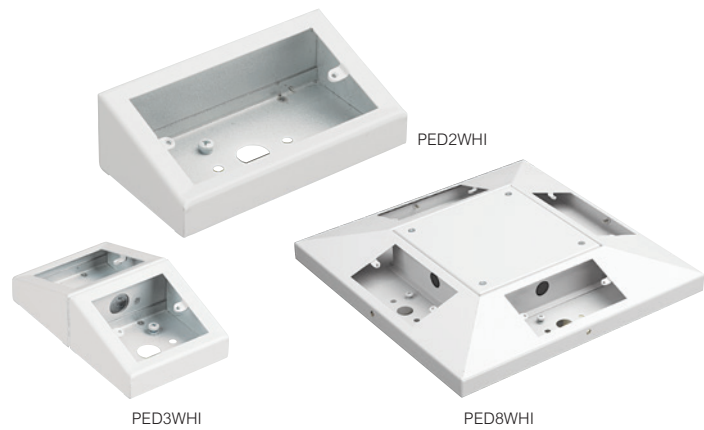

Dimensions and technical information **opposite**

Material : zinc coated mild steel to BS EN 10152
 Colour : white epoxy powder coated, RAL 9003. For other colours, please specify RAL number
 Zintec finish is available on request (Zintec pedestal units are to be painted on site)

Pack	Cat. Nos.	Pedestal units	
1	PED1WHI	Single socket	
1	PED2WHI	Twin socket	
1	PED3WHI	Back-to-back single sockets	
1	PED4WHI	Back-to-back twin sockets	
1	PED8WHI	Pyramid box	

Pedestal units are available in other dimensions and finishes to special order

Contact us on +44 (0) 370 608 9020

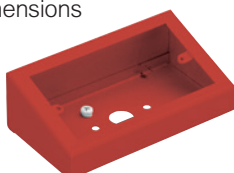

■ Pedestal units dimensions

Single socket

A	54
B	89
C	102
D	24

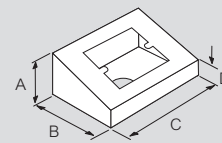

Cat. No. PED1WHI

Twin socket

A	54
B	89
C	162
D	24

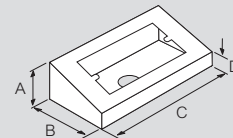

Cat. No. PED2WHI

Back-to-back sockets

Single socket

A	54
B	178
C	102
D	24

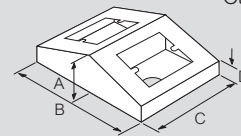

Cat. No. PED3WHI

Twin socket

A	54
B	178
C	162
D	24

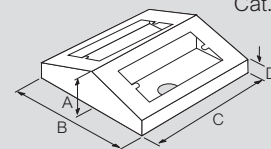

Cat. No. PED4WHI

For all pedestal units above, hole diameter in base is 20 mm

Pyramid box

A	55
B	368
C	184
D	24

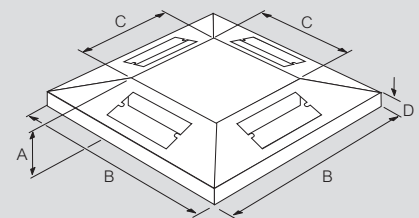

Cat. No. PED8WHI

wiring accessories



7300 60 7300 65 6781 38



7300 70 8330 65 7300 34

Pack	Cat. Nos.
1	MP820329
1	MP820339

Back boxes

Socket back boxes

Material : pre-galvanised steel

1 gang back box

2 gang back box

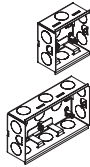

8330 93



5721 17



5720 78

Pack	Cat. Nos.	
	White	Brushed stainless steel
10 / 1	7300 91	8330 91
10 / 1	7300 92	8330 92
10 / 1	7300 93	8330 93
10 / 1	7300 94	8330 94

Carrier plates for Arteor modules

No additional support frame required

	White	Brushed stainless steel
1 gang – 1 module plate		
1 gang – 2 module plate		
2 gang – 3 module plate		
2 gang – 4 module plate		

Pack	Cat. Nos.	
	White	Brushed stainless steel
10 / 1	7300 60	8330 60
5 / 1	7300 70	8330 70
10 / 1	7300 65	8330 65
5 / 1	7300 75	8330 75
1	6781 34	8330 86
1	6781 38	8330 98
10 / 1	7300 34	8330 34
10 / 1	7300 36	8330 37 ¹

Synergy sockets (monobloc)

Double pole switched socket outlets 13 A - 250 V

Conform to BS 1363 - Part 2 : 1995

10 / 1 7300 60 8330 60 1 gang – switched

5 / 1 7300 70 8330 70 2 gang – switched

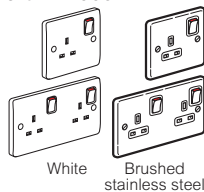

Unswitched socket outlets 13 A - 250 V

Conform to BS 1363 - Part 2 : 1995

10 / 1 7300 65 8330 65 1 gang – unswitched

5 / 1 7300 75 8330 75 2 gang – unswitched

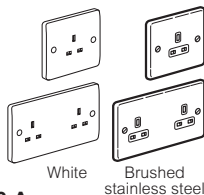

RCD socket outlets 13 A - 250 V ELR - DP 30 mA - passive

Conform to BS 7288 : 1990 and BS 1363 - Part 2 : 1995
Maximum operating current 16 A
With "Test and reset" button
Does not trip in the event of power failure
Suitable in applications where automatic restoration of supply is required

1 6781 34 8330 86 1 gang – DP

1 6781 38 8330 98 2 gang – DP

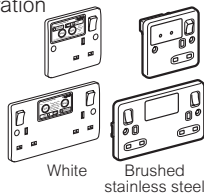

Fused connection units 13 A - 250 V

Conform to BS 1363 - Part 4 : 1995

10 / 1 7300 34 8330 34 1 gang – Switched, DP without cord outlet

10 / 1 7300 36 8330 37¹ 1 gang – Switched, DP with cord outlet

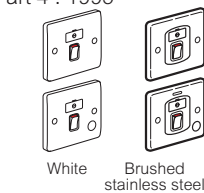

Pack	Cat. Nos.	
	White	Magnesium
5	5721 30	5726 30
5	5724 67	Red
	White	Magnesium
10	5720 21	5725 21
10	5721 17	5726 17
5 / 1	5720 78	5725 78
1	5720 96	5725 96
10	5723 23	5728 23
10	5723 22	5728 22
10	5723 04	5728 04
10	5723 03	5728 03

Arteor modules

British standard 13 A socket outlets

Conform to BS 1363 - Part 2
ASTA license
3 modules – 2P + E switched

5 5721 30 5726 30

5 5724 67 3 modules – 2P + E switched dedicated non-standard pin



International standards socket outlets

Not suitable for domestic installations in the UK or Ireland
French – 10/16 A
2 modules – 2P + E shuttered for child safety
American – 15 A - 127 V
2 modules – 2P + E

10 5720 21 5725 21

10 5721 17 5726 17



Double USB sockets – 5 V - 2400 mA

For fast-charging telephones, smartphones, MP3/MP4 players and tablet PC
2 modules

5 / 1 5720 78 5725 78



HDMI audio and video sockets

Preconnected
Equipped with a 15 cm cord
1 module

1 5720 96 5725 96



RJ45 data sockets

Rapid connection sockets
No tool required

CAT 6 – STP - 9 contacts, shielded folded metal. 1 module

10 5723 23 5728 23

CAT 6 – FTP - 9 contacts. 1 module

10 5723 22 5728 22

CAT 5e – FTP - 9 contacts. 1 module

10 5723 04 5728 04

CAT 5e – UTP - 8 contacts. 1 module

10 5723 03 5728 03



For complete range of wiring accessories
see **Legrand's website**
www.legrand.co.uk



1: With blue 'power on' LED indicator

steel perimeter trunking

technical information

Compliance

A steel perimeter trunking system with strength and rigidity manufactured using pre-galvanised steel to BS EN 10346 : 2009 grade DX51D. Manufactured to BS EN 50085-2-1 : 2006 in BS EN ISO9001 : 2008 and BS EN ISO14001 : 2004 approved facilities. Trunking is supplied as standard powder coated with LSF powder to RAL 9010 "Pure White" with a safety return edge. Covers are supplied as push-fit and are designed to give excellent earth continuity without extra components.

Classification to BS EN 50085-1 : 2005 and BS EN 50085-2-1 : 2006

Clause 6.2 According to resistance to impact for installation and application :

Impact 2·0J when used in conjunction with IK 07 accessories

Clause 6.3 According to temperatures given in the table below :

	Min.	Max.
1. Storage and transport	-25°	-
2. Installation	-15°	-
3. Application	-	+60°

Clause 6.4 According to resistance to flame propagation :
Non-flame propagating

Clause 6.5 According to electrical continuity characteristic :
CTS with electrical continuity (maximum linear impedance 1·0 milliohms per metre)

Clause 6.6 According to electrical insulating characteristic :
CTS without electrical insulating characteristic

Clause 6.7 According to degree of protection provided by enclosure according to BS EN 0529 : 1991 :

IP 30 – standard range
IP 40 – when used with IP 40 accessories

Clause 6.9 According to system access cover retention :
CTS access cover which can only be opened with a tool when installation is complete

Clause 6.10 According to electrically protective separation :
CTS without internal protective partition

Clause 6.101 According to position when surface mounted :
CTS surface mounted on wall

Clause 6.103 According to the functions provided :
Type 2 CTS (installation)

Sizes available

There are four sizes of body within the range, these are :

110 x 63 mm 130 x 63 mm 170 x 63 mm 170A x 63 mm

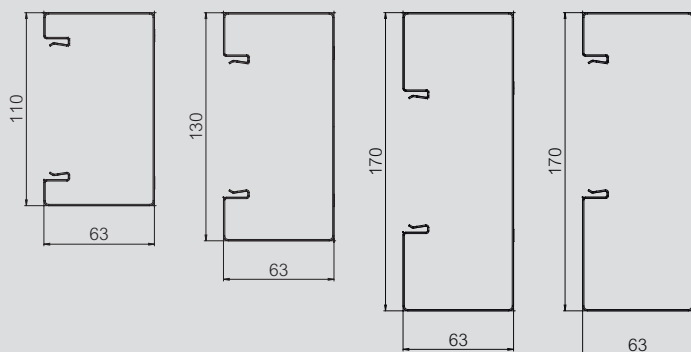

110, 130, 170 and 170A systems are all suitable for dado applications. 170 and 170A are also suitable for skirting applications. Ensure clearance between trunking body and floor finish is allowed to fit the cover straps etc.

Each of these sizes can be configured with 2 or 3 compartments with the option of a base divider giving a maximum potential of 4 compartmented areas within the trunking.

All dimensions (mm) are nominal

Compartment options

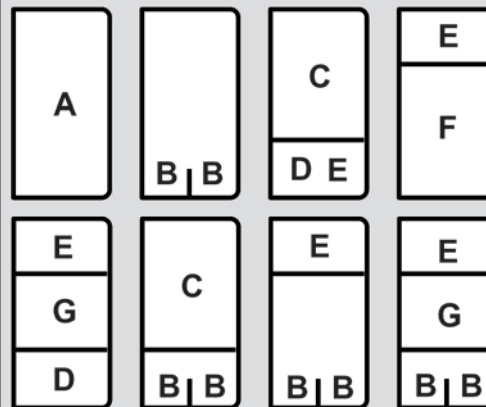

Cable capacity

Full capacity mm² per compartment area

Trunking Size	Back box without		Back box with		Back box without		Back box with		
	without	with	without	with	without	with	without	with	
110 x 63	110 x 63		130 x 63		170 x 63		170A x 63		
Compartment	A	6 408	3 348	7 628	4 568	10 068	7 008	10 068	7 008
	B	-	-	616	616	1 260	1 260	1 260	1 260
	C	4 607	2 087	5 217	2 697	6 437	3 917	5 217	2 697
	D	1 801	1 261	2 411	1 871	3 631	3 091	4 851	4 311
	E	1 801	1 261	2 411	1 871	3 631	3 091	2 411	1 961
	F	4 607	2 087	5 217	2 697	6 437	3 917	7 657	5 047
	G	2 806	826	2 806	826	2 806	826	2 806	736

For each size of cable multiply the number to be installed by its own common factor. Add together the results of these calculations for all cable sizes. The resulting sum should be equal to or less than the trunking capacity. It is recommended that each compartment should not be filled over 45% of its full capacity.

Common cable factors

If the cable is not shown in the table below then the factor (area) can be calculated by :

Measuring diameter
Dividing diameter by 2 to give the radius
Area = 3·142 x radius x radius
e.g.

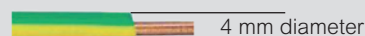

$$3 \cdot 142 \times 2 \times 2 = 12 \cdot 6 \text{ mm}^2$$

Cable factors : power		
	Conductor size mm ²	Factor
Solid	1·5	8·0
Solid	2·5	11·9
Stranded	1·5	8·6
Stranded	2·5	12·6
Stranded	4·0	16·6
Stranded	6·0	21·2

Cable factors : data		
	Ø mm	Factor
5e. UTP	5·5	30·2
5e. STP	6·0	36·0
6 UTP	6·5	42·2
6 STP	7·0	49·0

steel perimeter trunking

technical information

■ Dimensions

110 x 63 mm

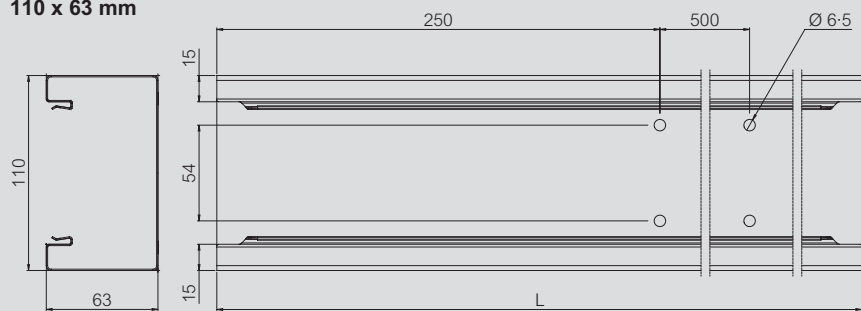

130 x 63 mm

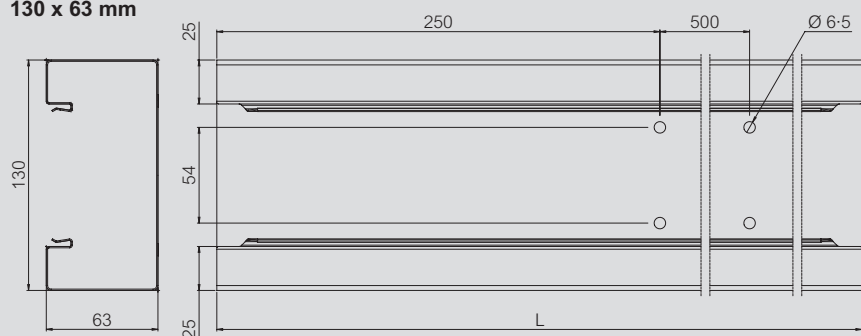

170 x 63 mm

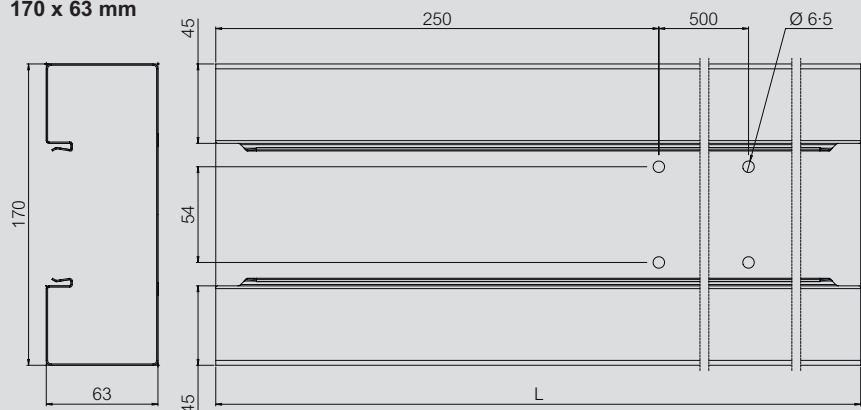

170A x 63 mm

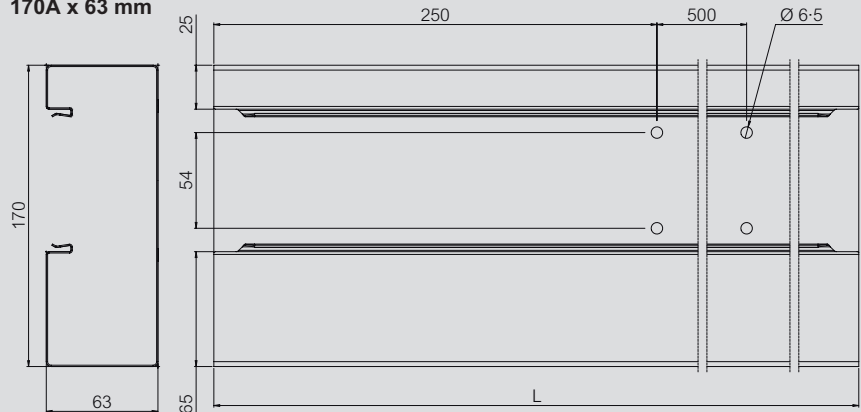

Material thickness : 1 mm

All dimensions (mm) are nominal

steel perimeter trunking

technical information

■ Weights

Trunking size	Product							
	110		130		170		170A	
	Cat. Nos.	Weight	Cat. Nos.	Weight	Cat. Nos.	Weight	Cat. Nos.	Weight
Body 3 m	MP351233	5·56	MP351235	6·27	MP351236	7·68	MP351237	7·68
Lid 1·5 m	MP351230	0·98	MP351230	0·98	MP351230	0·98	MP351230	0·98
Accessory spacer lid 100 mm	MP351220	0·07	MP351220	0·07	MP351220	0·07	MP351220	0·07
Coupler ¹	MP351523	0·08	MP351525	0·09	MP351526	0·05	MP351527	0·11
Universal internal/external bend lid	MP351173	0·23	MP351175	0·24	MP351176	0·27	MP351177	0·27
Internal bend cover straps	MP351203	0·37	MP351205	0·37	MP351206	0·38	MP351207	0·38
Internal bend body	MP351273	0·47	MP351275	0·52	MP351276	0·62	MP351277	0·62
External bend body	MP351303	0·53	MP351305	0·59	MP351306	0·71	MP351307	0·71
External bend lid	MP351240	0·26	MP351240	0·26	MP351240	0·26	MP351240	0·26
Flat bend body	MP351333	0·44	MP351335	0·65	MP351336	1·09	–	–
Flat bend lid	MP351260	0·21	MP351260	0·21	MP351260	0·21	MP351260	0·21
Flat bend body rising	–	–	–	–	–	–	MP351337	1·08
Flat bend body descending	–	–	–	–	–	–	MP351367	1·10
Tee body	MP351393	0·62	MP351395	0·74	MP351396	0·99	–	–
Tee body rising	–	–	–	–	–	–	MP351397	0·96
Tee cover strap	MP351563	0·15	MP351565	0·20	MP351566	0·30	MP351567 ² MP351597 ³	0·29
End cap	MP351043	0·08	MP351045	0·08	MP351046	0·10	MP351046	0·10
Cover strap	MP351103	0·05	MP351105	0·06	MP351106	0·07	MP351107	0·07
Tolerance cover strap	MP351073	0·09	MP351075	0·10	MP351076	0·11	MP351077	0·11
Wall flange plate	MP351483	0·05	MP351485	0·05	MP351486	0·06	MP351486	0·06
Wall flange closing plate	MP351513	0·03	MP351515	0·03	MP351516	0·04	MP351516	0·04
Support flange	MP351453	0·13	MP351455	0·14	MP351456	0·15	MP351456	0·15
Riser trunking body ¹ – 2 m	MP351409	5·60	MP351409	5·60	MP351409	5·60	MP351409	5·60
Riser trunking lid – 1 m	MP351439	1·47	MP351439	1·47	MP351439	1·47	MP351439	1·47
Earthing wire	MP351499	0·01	MP351499	0·01	MP351499	0·01	MP351499	0·01
Universal snapper clip ¹	MP351319	0·06	MP351319	0·06	MP351319	0·06	MP351319	0·06
Divider ¹ – 1 m	MP351189	0·36	MP351189	0·36	MP351189	0·36	MP351189	0·36
Base divider ¹ – 2 m	–	–	MP351279	0·47	MP351289	0·66	MP351289	0·66
Base divider fixing bracket ¹	–	–	MP351299	0·02	MP351309	0·02	MP351309	0·02
Internal lid support ¹	MP351469	0·03	MP351469	0·03	MP351469	0·03	MP351469	0·03
Internal bend lid	MP351250	0·12	MP351250	0·12	MP351250	0·12	MP351250	0·12
End support bracket ¹	MP351449	0·03	MP351449	0·03	MP351449	0·03	MP351449	0·03
Tee support bracket ¹	MP351459	0·03	MP351459	0·03	MP351459	0·03	MP351459	0·03
Acoustic insulation block	MP351389	0·05	MP351389	0·05	MP351399	0·05	MP351399	0·05
Cutting support block	MP351533	1·51	MP351535	1·64	MP351536	1·89	MP351536	1·89
Touch-up paint	MP351029	0·04	MP351029	0·04	MP351029	0·04	MP351029	0·04
1 gang back box	MP820329	0·85	MP820329	0·85	MP820329	0·85	MP820329	0·85
2 gang back box	MP820339	0·15	MP820339	0·15	MP820339	0·15	MP820339	0·15

1 : Internal components supplied unpainted

2 : Rising to 170 mm wide trunking 3 : Rising to 130 mm wide trunking

steel perimeter trunking

technical information

■ Supporting cable trunking systems

The connector between all types of cable trunking lengths is to provide electrical and mechanical connection between the lengths ; it does not provide a load bearing connection between lengths. Consequently each length must be fully secured to the wall so that there is no significant bending force applied to the connector

■ Electromagnetic compatibility (EMC)

Cable trunking and duct systems are considered passive under normal conditions in respect of electromagnetic influences. The installation of current carrying cables may cause emissions and these cables may also be influenced by electromagnetic signals from elsewhere, but the degree of influence will depend on the nature of the installation and the apparatus connected to the system. Specific information relating to the details of cable separation required according to the type of signal, and further information on the subject of EMC, is provided in the relevant Standards and Regulations. However, as a basic principle, if power and data cables are run in separate compartments of a metal trunking system, then the metal segregation will significantly reduce the possibility of one circuit having an undesirable effect upon another

■ Installation

110, 130, 170 and 170A systems are all suitable for dado applications
170 and 170A systems are also suitable for skirting applications
Ensure clearance between trunking body and floor finish is allowed to fit the cover straps etc

The system is designed to fit together without the use of screws on the body, lid or component parts, with the exception of the wiring accessory back box which has a screw to secure a sliding plate into the body

Trunking body

The trunking body has fixing points every 500 mm and 250 mm from each end

It is recommended to secure at least every metre and near to joints / ends

Use washers and dome head screws or plastic caps to avoid damage to cables

Do not over tighten

Fit trunking body to wall ensuring it is level with preceding length and that joints are closely butted together

Once secured, install earthing coupler to trunking joint by simply pushing into place ensuring that the coupler is evenly distributed over both parts

For best results when cutting, use a fine tooth circular saw

Cut edges must be de-burred to avoid cable damage

The trunking body is supplied with a protective film to avoid marks and scratches during installation ; this can be removed when lids are fitted

Fittings

Fittings (e.g. bends, tees) are installed in the same manner as the trunking body

Dividers

The trunking can be divided into two or three compartments

Dividers are supplied in 1 m lengths and have rolled edges for safety

The multifunction snapper clips into the base and provides two locations to fit the dividers

The snapper is earthed to the trunking body and dividers automatically when installed

One snapper is required per metre

Additional snapper clips may be required at the end of the run and closer to back boxes. The snapper also provides additional support to the lid

A base divider is also available to further separate the base compartment if required

Back boxes

The 35 mm deep steel back boxes are slotted into place and secured by sliding the two fixing brackets under the return and tightening the screws
Boxes are designed to have some lateral movement for final adjustments
Marks in the rear of the trunking body every 100 mm allow for easy positioning

20 mm knockouts are provided on all sides and the base. Once removed, 20 mm grommets should be fitted to protect the cable from the cut edge before feeding cable into box

Lids

Once the wiring installation is complete, lids are simply clicked into place

Earthing cams are located every 150 mm

Minimum length of lid should be 50 mm and include at least one earthing cam

To remove, the lids should be carefully lifted from one end

This can be from any joint, fitting or wiring accessory location

If the installation comprises a single length between two walls, a coupler joint is required in the centre to aid lid removal

25 mm wide cover straps are available to provide a neat finish at lid and body joints

These clip into place over the completed trunking run after the lids have been fitted

A wider (40 mm) tolerance cover strap is also available

Earthing

The Legrand steel perimeter trunking system is designed with parts that provide earth continuity when installed, however, the connection to earth is the responsibility of the installer. Legrand provides the means to achieve a correct and safe installation. It is the responsibility of the installer to determine the number and position of earth connections

3 simple steps... to choose the right solution

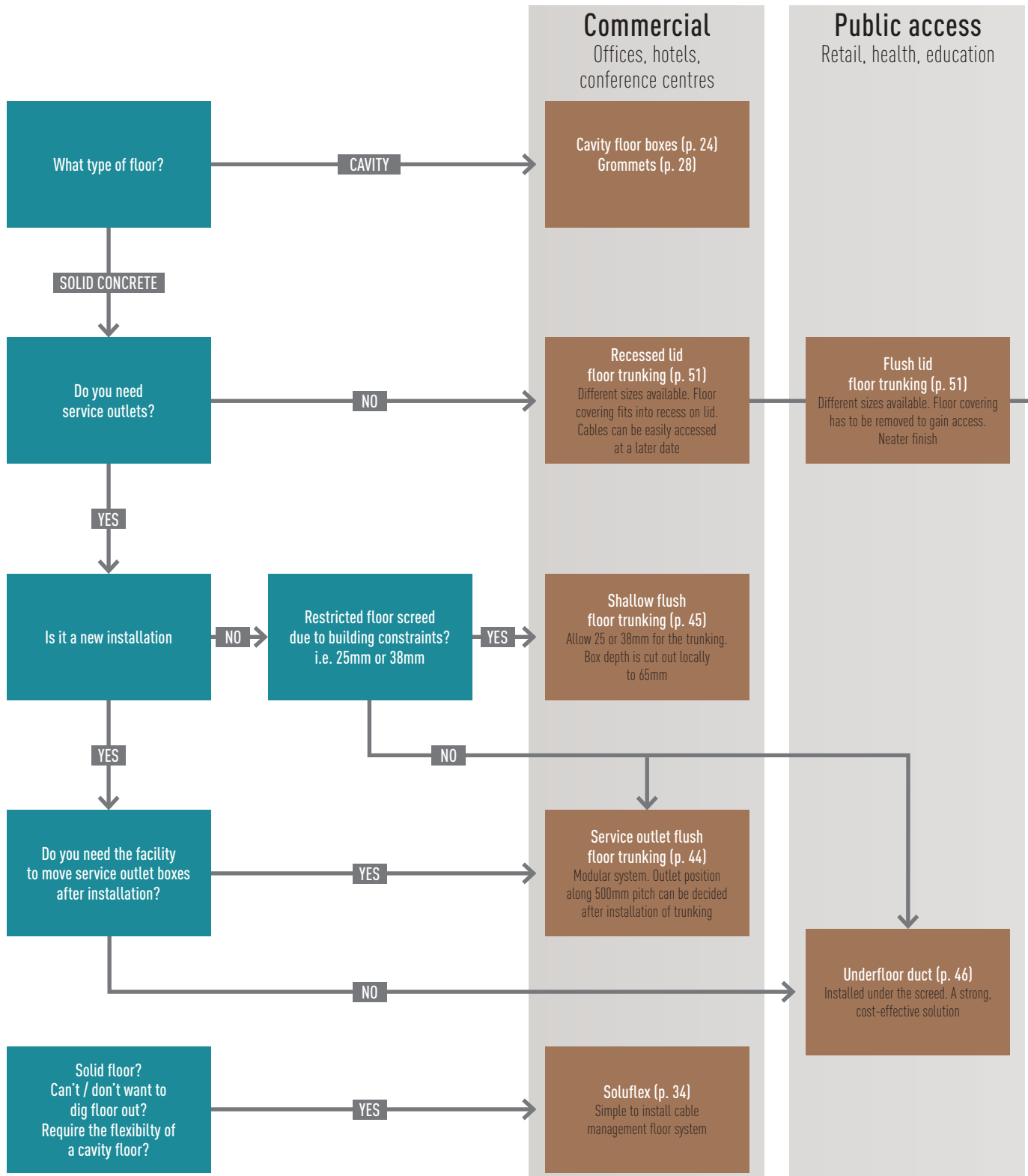

Whatever the scenario, Legrand has the ideal solution to provide power and data to the workstation.

The flowchart below guides you to the most suitable system for your project. If traditional floor systems are struggling to meet your requirements, Soluflex provides the simple answer to a myriad of challenges.

Industrial

Warehousing,
heavy duty infrastructure

Chequer plate floor trunking (p. 52)

Different sizes available, suitable for
heavy industrial type areas

Choose the correct system for your application

1

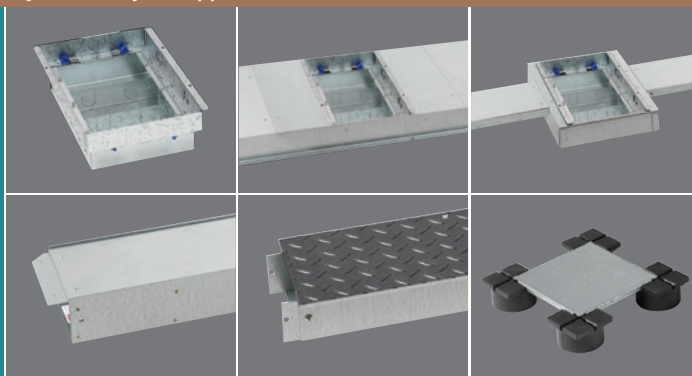

Select the power and data plates you require

2



Choose the most suitable lid and trim for the floor finish and surroundings

3

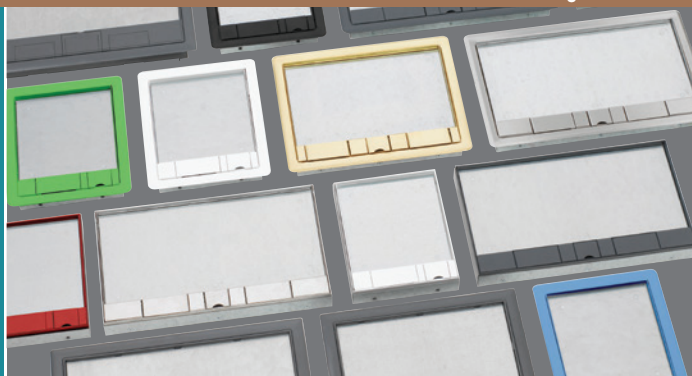

CAVITY FLOOR BOXES

building
on success

Legrand's latest range of cavity floor boxes offer a modular product that is simple to order. Components are sold separately enabling any configuration to be accommodated on site.

Available in 1, 2, 3 and 4 compartments and three depths - the range has been developed with a host of special features:

- Rapid fit and remove mechanism
- Reversible lid
- Push-fit detail to secure base in the floor
- 1 compartment floor box is designed to easily accommodate moulded plugs

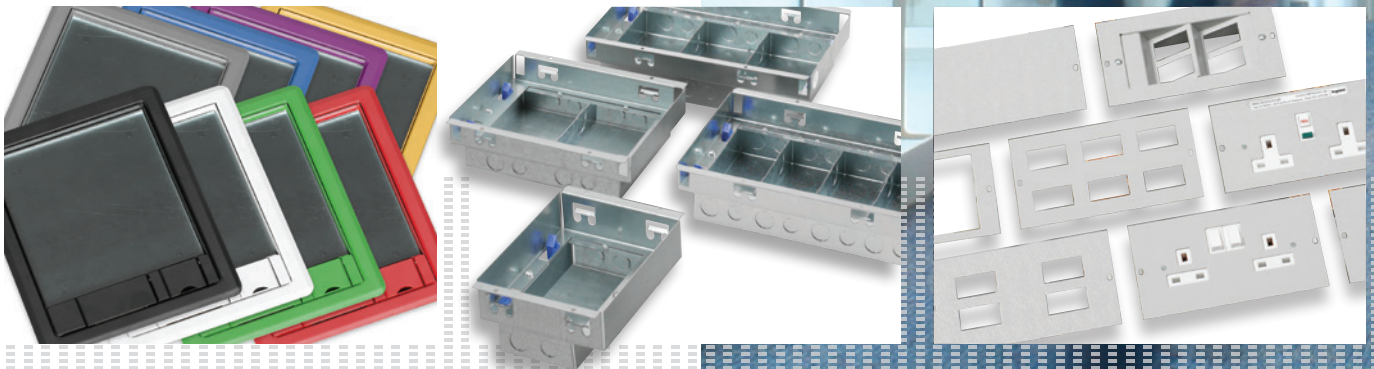

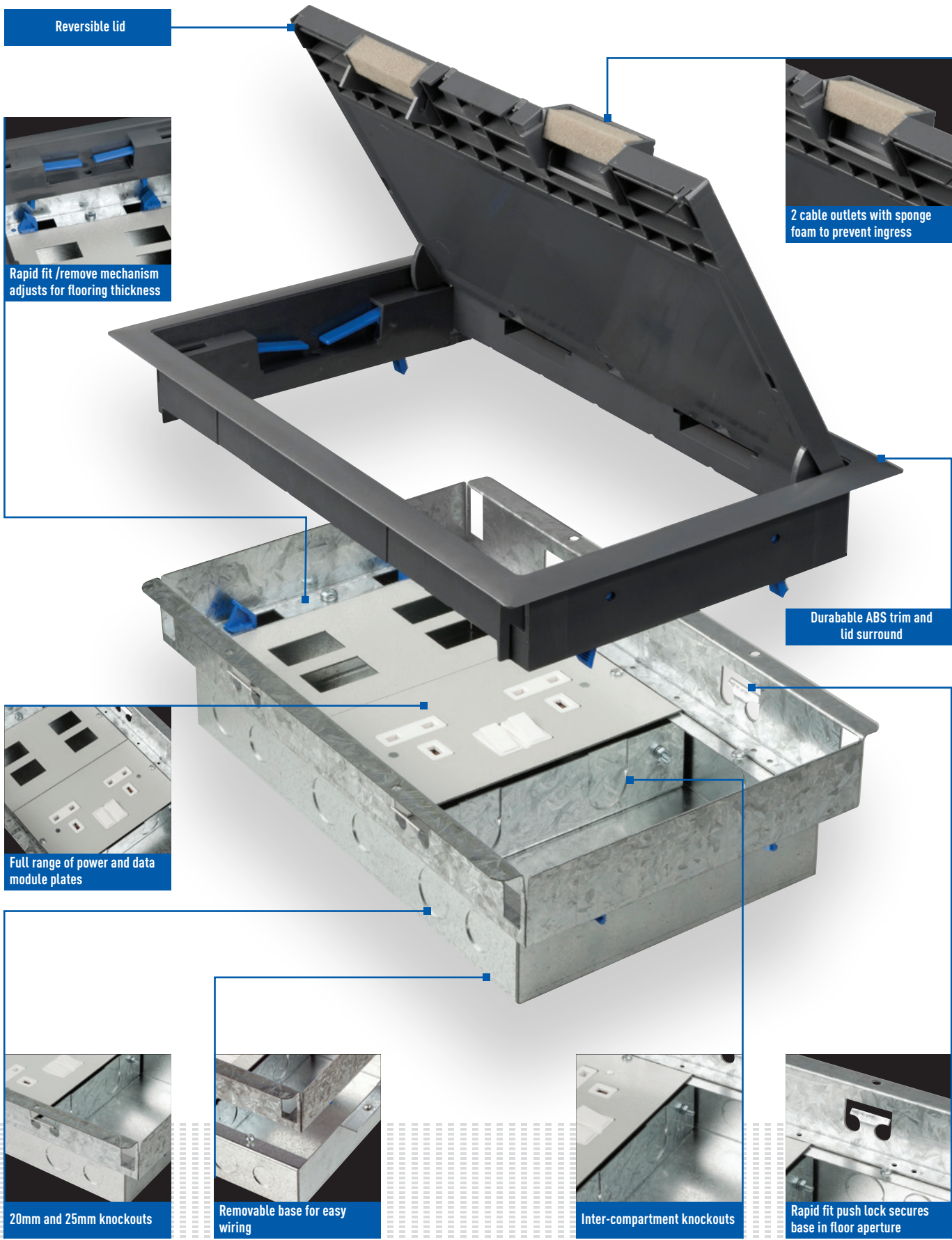

Reversible lid

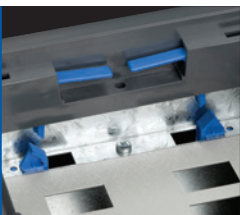

Rapid fit /remove mechanism adjusts for flooring thickness



2 cable outlets with sponge foam to prevent ingress



Durable ABS trim and lid surround



Full range of power and data module plates

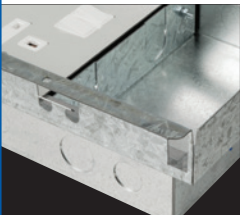

20mm and 25mm knockouts

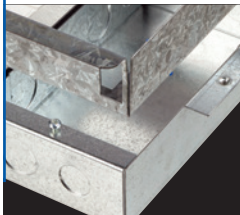

Removable base for easy wiring





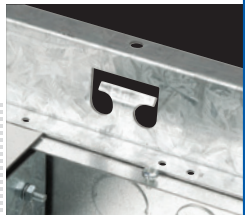

Inter-compartment knockouts

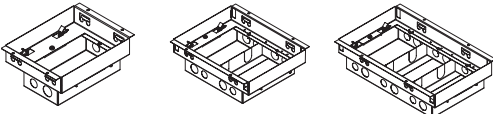
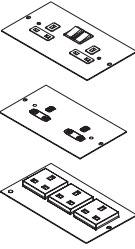
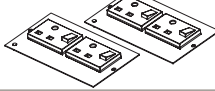

Rapid fit push lock secures base in floor aperture

cavity floor service outlet boxes

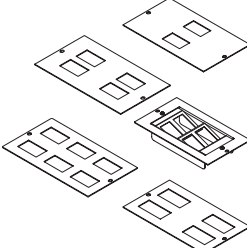
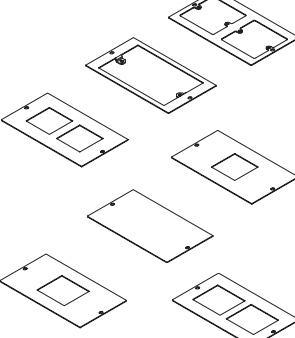
selection chart

No. of compartments		
Floor box base		
Depth 	Cavity floor box base – 75 mm deep	
	Cavity floor box base – 85 mm deep	
	Cavity floor box base – 110 mm deep	
Outlet plates		
13 A standard 	13 A twin switched socket plate	
	13 A twin unswitched socket plate	
	13 A twin switched clean earth socket plate	
	13 A triple unswitched socket plate	
	13 A triple unswitched clean earth socket plate	
13 A non-standard 	13 A twin NS switched socket plate	
	13 A twin NS switched clean earth socket plate	
RCD 30 mA passive 	2 gang RCD socket plate	
	2 gang RCD socket plate – clean earth	
Data 	37 x 22 mm – 2 cut-out plate	
	37 x 22 mm – 4 cut-out plate	
	37 x 22 mm – 4 cut-out wave plate	
	37 x 22 mm – 6 cut-out plate	
	47.5 x 23.5 mm – 4 cut-out plate	
General 	2 x standard single outlet 60.3 mm	
	Standard 2 gang outlet plate 120.6 mm	
	51 x 51 mm – 1 cut-out plate	
	51 x 51 mm – 2 cut-out plate	
	Blank plate	
	58 x 53.5 mm – 1 cut-out plate to accept Arteor mounting frame ¹	
	58 x 53.5 mm – 2 cut-out plate to accept 2 x Arteor mounting frames ¹	
Lids and trims		
	ABS with carpet trim – 6 mm recess	
	Combination with edge trim – 6 mm recess	
	Metal, powder coated with carpet trim – 8 mm recess (RAL 7024)	
	Metal, powder coated with edge trim – 8 mm recess (RAL 7024)	
	Stainless steel with carpet trim – 8 mm recess (Satin)	
	Stainless steel with edge trim – 8 mm recess (Satin)	
	Brass with carpet trim – 8 mm recess (Polished)	
	Brass with edge trim – 8 mm recess (Polished)	

¹ : For Arteor mounting frames, refer to the latest Wiring Devices catalogue

	1 compartment	2 compartment	3 compartment	4 compartment
	–	CAV275	CAV375	CAV475
	CAV185	CAV285	CAV385	CAV485
	–	CAV2110	CAV3110	CAV4110
	SP3201	SP3201	SP3201	SP4201
	SP3200	SP3200	SP3200	SP4200
	SP3211	SP3211	SP3211	SP4211
	SP3300	SP3300	SP3300	SP4300
	SP3310	SP3310	SP3310	SP4310
	SP3221	SP3221	SP3221	SP4221
	SP3231	SP3231	SP3231	SP4231
	SP3202	SP3202	SP3202	SP4202
	SP3212	SP3212	SP3212	SP4212
	SP3203	SP3203	SP3203	SP4203
	SP3403	SP3403	SP3403	SP4403
	SP3404	SP3404	SP3404	SP4404
	SP3603	SP3603	SP3603	SP4603
	SP3408	SP3408	SP3408	SP4408
	SP3205	SP3205	SP3205	–
	SP3105	SP3105	SP3105	–
	SP3106	SP3106	SP3106	SP4106
	SP3206	SP3206	SP3206	SP4206
	SP3000	SP3000	SP3000	SP4000
	SP3107	SP3107	SP3107	SP4107
	SP3207	SP3207	SP3207	SP4207
	–	FBL2ABS	FBL3ABS	FBL3ABS
	–	FBL2COM	FBL3COM	FBL3COM
	FBL1MCT	FBL2MCT	FBL3MCT	FBL3MCT
	FBL1MET	FBL2MET	FBL3MET	FBL3MET
	FBL1SCT	FBL2SCT	FBL3SCT	FBL3SCT
	FBL1SET	FBL2SET	FBL3SET	FBL3SET
	FBL1BCT	FBL2BCT	FBL3BCT	FBL3BCT
	FBL1BET	FBL2BET	FBL3BET	FBL3BET

cavity floor service outlet boxes

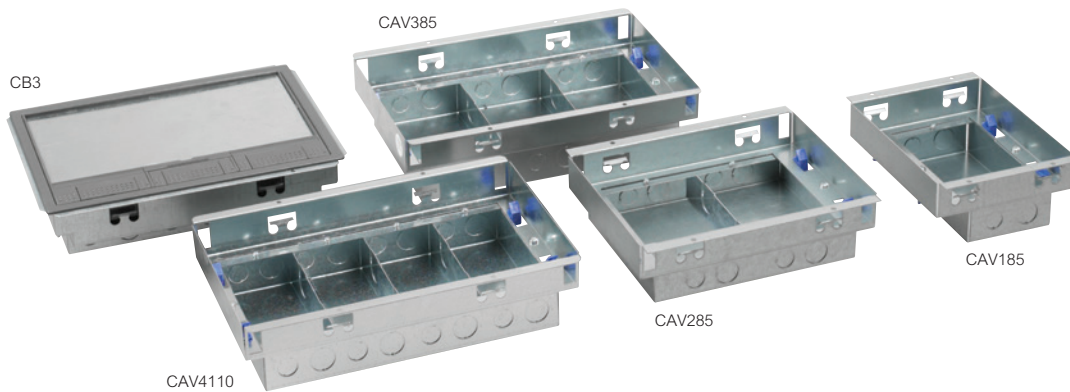

Cavity floor outlet boxes selection chart **p. 24-25**
 Dimensions and technical information **p. 28**
 Installation details **p. 29**

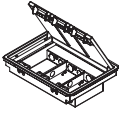
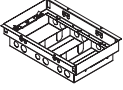
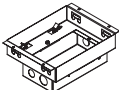
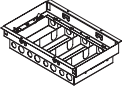
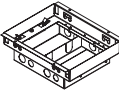
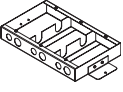
Pack	Cat. Nos.	Cavity floor boxes	Pack	Cat. Nos.	Cavity floor boxes (continued)
1	CB3	Contractor floor box Supplied empty Ready to accept standard BS two gang wiring accessories Additional mounting plates not required Recommended hole cut-out size : 302-304 mm x 219-221 mm 7 mm lid recess Standard depth : 85 mm 20/25 mm knockouts to each compartment Manufactured from pre-galvanised steel to BS EN 10142 and 3, and polycarbonate/ABS 3 compartment contractor floor box 	1	CAV375	3 compartment floor box base Recommended hole cut-out size : 340-342 mm x 203-205 mm 75 mm deep 85 mm deep 110 mm deep 
1	CAV185	Floor box bases Supplied empty Lids and trims are detailed on p. 27 Outlet plates are detailed on p. 27 1 compartment floor box base Recommended hole cut-out size : 165-167 mm x 203-205 mm 85 mm deep 	1	CAV475	4 compartment floor box base Recommended hole cut-out size : 340-342 mm x 203-205 mm 75 mm deep 85 mm deep 110 mm deep 
1	CAV275	2 compartment floor box base Recommended hole cut-out size : 263-265 mm x 203-205 mm 75 mm deep 	1	SLAB1	Slab floor box 1 compartment 2 compartment 3 compartment 4 compartment 
1	CAV285	85 mm deep	1	SLAB2	2 compartment
1	CAV2110 ¹	110 mm deep	1	SLAB3	3 compartment
			1	SLAB4	4 compartment

1 : 110 mm deep base boxes not suitable for edge trim lids

outlet plates for floor boxes

power and data

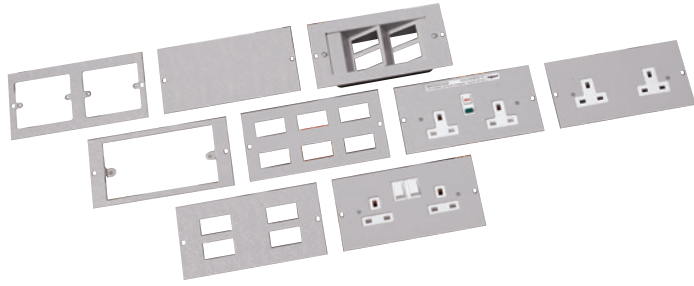

Cavity floor outlet boxes selection chart **p. 24-25**
Dimensions and technical information **p. 28**
Installation details **p. 29**

Plates to fit 1, 2 and 3 compartment boxes are all 100 mm wide
Plates to fit 4 compartment boxes are 75 mm wide
Non-standard sockets have a round earth pin
Due to overall depth, RCD sockets and wave type data plates will NOT fit in the flush floor and shallow flush floor ranges (Cat. Nos. FFO/AFS)
When using with underfloor duct systems (Cat. No. AFU) the outlet box must be raised by 8 mm from the lowest point to allow for wiring

Pack	Cat. Nos.		Power and data plates
	1, 2, 3 comp. 100 mm wide	4 comp. 75 mm wide	
			13 A standard socket plates
1	SP3201	SP4201	Twin switched
1	SP3200	SP4200	Twin unswitched
1	SP3211	SP4211	Twin switched – clean earth
1	SP3300	SP4300	Triple unswitched
1	SP3310	SP4310	Triple unswitched – clean earth
			13 A non-standard socket plates
1	SP3221	SP4221	Twin NS switched
1	SP3231	SP4231	Twin NS switched – clean earth
			RCD socket plates
			Double pole 30 mA passive will not trip in event of power failure. Eliminating need to manually reset all units after power failure
1	SP3202	SP4202	2 gang
1	SP3212	SP4212	2 gang – clean earth
			Data plates
1	SP3203	SP4203	37 x 22 mm – 2 cut-outs
1	SP3403	SP4403	37 x 22 mm – 4 cut-outs
1	SP3404	SP4404	37 x 22 mm – 4 cut-outs (wave plate)
1	SP3603	SP4603	37 x 22 mm – 6 cut-outs
1	SP3408	SP4408	47.5 x 23.5 mm – 4 cut-outs
			General
1	SP3205	-	2 x standard single outlet 60.3 mm
1	SP3105	-	Standard 2 gang outlet plate 120.6 mm
1	SP3106	SP4106	51 x 51 mm – 1 cut-out plate
1	SP3206	SP4206	51 x 51 mm – 2 cut-out plate
1	SP3000	SP4000	Blank plate
1	SP3107	SP4107	58 x 53.5 mm – 1 cut-out plate to accept Arteor mounting frame (Cat. No. 576016) ¹
1	SP3207	SP4207	58 x 53.5 mm – 2 cut-outs plate to accept 2 x Arteor mounting frames (Cat. No. 576016) ¹
			Fasteners
50	SPSCREW		M3.5 x 6 spare socket plate screws

1: For Arteor mounting frames, refer to the latest Wiring Devices catalogue

lids and trims for floor boxes



Cavity floor outlet boxes selection chart **p. 24-25**
Dimensions and technical information **p. 28**
Installation details **p. 29**

Moulded lids and trims are manufactured from durable ABS and feature a quick fit / release ratchet system
ABS lid and trim versions are supplied with 6 mm carpet recess
Metal lid and trim versions are supplied with 8 mm recess
Stainless steel is satin finish as standard
Brass is polished finish as standard

Pack	Cat. Nos.		Floor box lids and trims
	1 comp.	2 comp.	
			1 and 2 compartment
			Carpet trim
1	-	FBL2ABS	ABS
1	FBL1MCT	FBL2MCT	Metal – grey (RAL 7024)
1	FBL1SCT	FBL2SCT	Stainless steel (Satin)
1	FBL1BCT	FBL2BCT	Brass (Polished)
			Edge trim
1	-	FBL2COM	ABS lid/metal trim (ABS/grey)
1	FBL1MET	FBL2MET	Metal – grey (RAL 7024)
1	FBL1SET	FBL2SET	Stainless steel (Satin)
1	FBL1BET	FBL2BET	Brass (Polished)
			3 and 4 compartment
			Carpet trim
1	-	FBL3ABS	ABS
1	FBL3MCT	FBL3MCT	Metal – grey (RAL 7024)
1	FBL3SCT	FBL3SCT	Stainless steel (Satin)
1	FBL3BCT	FBL3BCT	Brass (Polished)
			Edge trim
1	-	FBL3COM	ABS lid/metal trim (ABS/grey)
1	FBL3MET	FBL3MET	Metal – grey (RAL 7024)
1	FBL3SET	FBL3SET	Stainless steel (Satin)
1	FBL3BET	FBL3BET	Brass (Polished)

Metal lids and trims can be powder coated to any RAL reference. Other options, such as lockable lids, are available to special order

Contact us on +44 (0) 370 608 9020

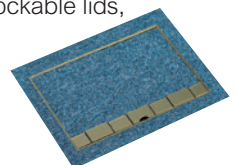

cavity floor service outlet boxes

technical information

■ Cavity floor service outlet boxes

Contractor floor box (Cat. No. CB3)

Cut-out 302-304 mm x 219-221 mm

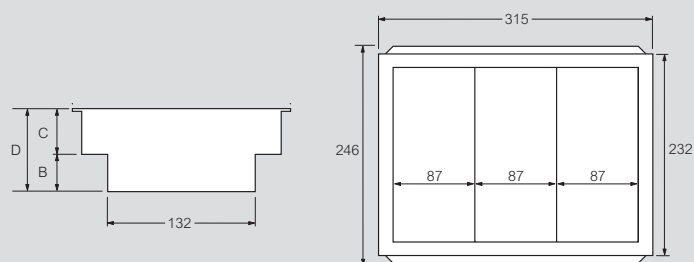

Floor box bases

Cat. No. CB3

Cat. No.	D	B	C	Cutout	
				W	L
CB3	81	35	46	303	220

Floor box bases

Cat. Nos. CAV1..., CAV2..., CAV3... and CAV4...

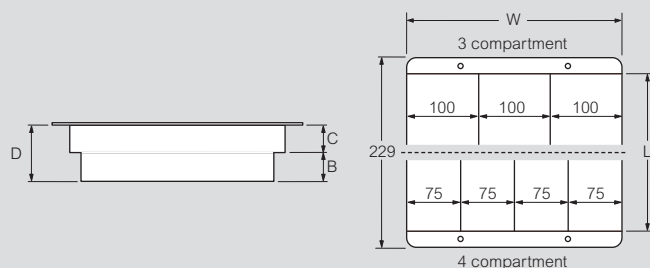

Cat. Nos.	D	B	C	Cutout		Plate Size
				W	L	
CAV185	85	45	40	165	203	100
CAV275	75	35	40	263	203	100
CAV285	85	45	40	263	203	100
CAV2110	110	45	65	263	203	100
CAV375	75	35	40	340	203	100
CAV385	85	45	40	340	203	100
CAV3110	110	45	65	340	203	100
CAV475	75	35	40	340	203	75
CAV485	85	45	40	340	203	75
CAV4110	110	45	65	340	203	75

Loading data

Load tests carried out to two standards BS EN (IEC) 61534 and BS EN (IEC) 50085

All tests performed in accordance to the above standards with boxes fitted with plastic lid and carpet trim assembly

Floor box – 1 & 2 compartment :

Small area (point load¹) – 1.5 kN

Large area (plate²) – 3.0 kN

Large Floor Box – 3 & 4 compartment :

Small area (point load¹) – 1.0 kN

Large area (plate²) - 3.0 kN

1 : Point load test = 13.3 mm diameter

2 : Plate load test = 130.0 mm diameter

■ Outlet plates

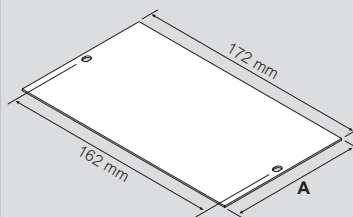

	A
1, 2, 3 comp.	100
4 comp.	75

■ Slab boxes

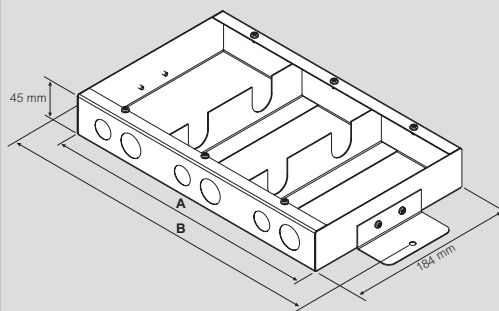

Cat. Nos.	A	B
Slab 1	102	162
Slab 2	202	262
Slab 3	302	362
Slab 4	302	362

All dimensions (mm) are nominal

cavity floor service outlet boxes

installation

Cut hole in floor tile

1

	Minimum	Maximum	Minimum	Maximum
	A		B	
1 compartment	165 mm	167 mm	203 mm	205 mm
2 compartment	263 mm	265 mm	203 mm	205 mm
3 compartment	340 mm	342 mm	203 mm	205 mm
4 compartment	340 mm	342 mm	203 mm	205 mm

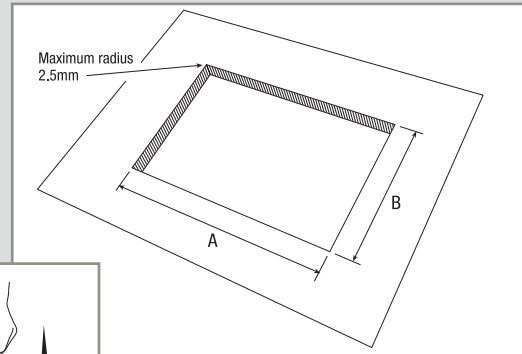

Install box

2

Lower base box into aperture and push firmly down
This will engage the fixing latches

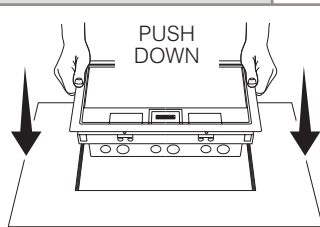

Fitting lid and trim

3

Lid and trim is a simple push fit
1 The ratchets allow the trim to find its own level on top of the final floor finish
2 To remove, lift out by releasing the blue locking handles

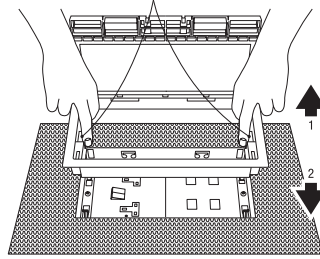

FOR SAFETY : All cables exiting boxes must be positioned into the cable routers on box trim and exit box via cable outlets
Lid and lid handle must always be placed in the closed positions
When using metal lid and trims, the lifting device at the centre of the lid is not to be used as a cable exit

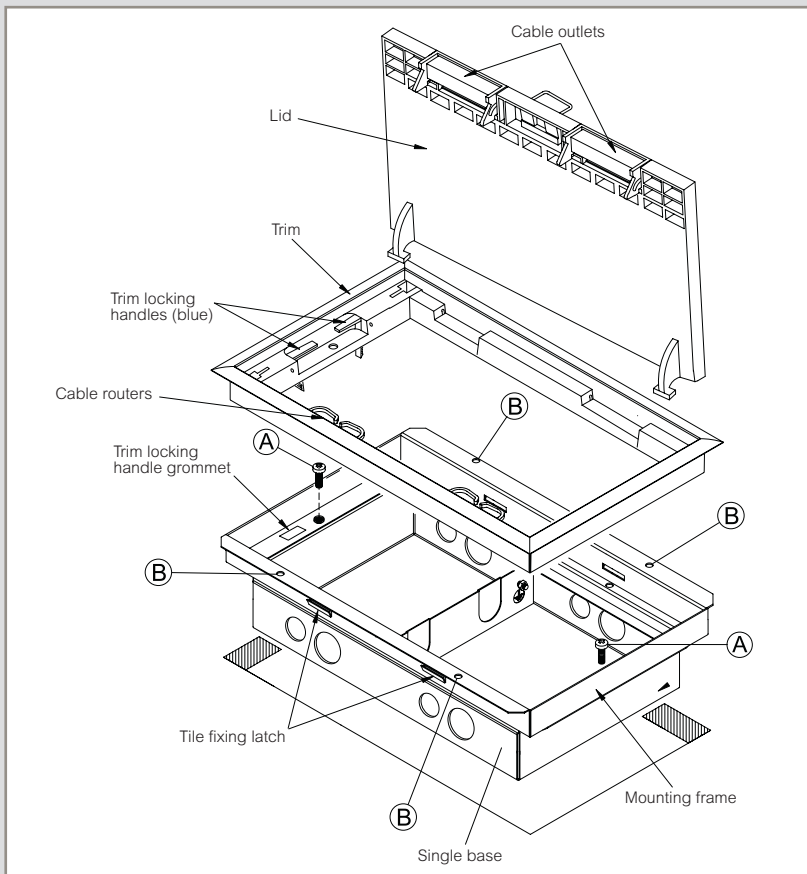

Opening lid to an angle of 30° and lifting upwards will detach lid from trim. Inserting lid into the opposite side of trim will change direction of the lid

Cable routers can also be removed and attached to opposite side of trim

A) Base can be detached from mounting frame by releasing screws (A)
This enables the base to be connected to the services and left under floor tiles for protection until the carpet, lid and trim are fitted

B) Box can be screw fitted to floor tile by using holes (B) in mounting frame
(If hole in tile is outside maximum tolerance Use 4 x No.8 25 mm self tapping screws)

cavity floor grommets



Dimensions and technical information p. 31

Pack	Cat. Nos.	150 mm plastic grommets
1	SG6	<p>Hole size 152 mm Carpet recess optional on power versions Secured by quarter-turn fasteners</p> <p>Access grommet Allows power, data and flexible conduit up to 32 mm to pass safely through raised access floor Maximum number of conduit entries : 9 x 20 mm Ø 5 x 25 mm Ø 3 x 32 mm Ø</p>
1	PG6	<p>13 A power grommet Supplied complete with 13 A unswitched socket</p>
1	PG6RCD	<p>RCD power grommet Supplied complete with 13 A RCD socket</p>
1	PG6PD	<p>13 A power/data grommet Supplied complete with 13 A socket and 1 x 37 x 22 mm cut-out</p>
1	PG6D	<p>Data grommet Supplied complete with data plate 2 x 37 x 22 mm cut-out</p>



Pack	Cat. Nos.	125 mm aluminium grommets
1	0893 07	<p>Hole size 127 mm Body – cast aluminium Lid – injection moulded plastic Nylon 66 with neoprene cable gasket Secured by quarter-turn fasteners Floor depth 25 to 55 mm Access grommet depth 60 mm (95 mm when back box included)</p> <p>Access grommet Allows power, data and flexible conduit up to 25 mm to pass safely through raised access floor</p>
1	AM1B	<p>13 A power grommet – unswitched Supplied complete with 13 A unswitched socket</p>
1	AM1C	<p>13 A power grommet – switched Supplied complete with 13 A switched socket</p>



Pack	Cat. Nos.	250 mm grommet
1	LSG2	<p>Hole size 250 mm Manufactured from polycarbonate/ABS Colour : grey to BS 4800 18B25 Secured by quarter-turn fasteners Floor depth 15 to 35 mm 7 mm lid recess Depth 55 mm</p> <p>Access grommet Allows power, data and flexible conduit up to 32 mm to pass safely through raised access floor</p>

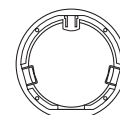

All power grommets are available pre-wired
Contact us on +44 (0) 370 608 9020

cavity floor grommets

technical information

■ 150 mm plastic grommets

Access grommet

Cat. No. SG6

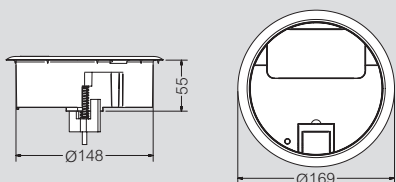

Power grommet

Cat. Nos. PG6 / PG6RCD / PG6PD / PG6D

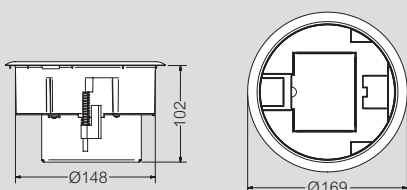

■ 125 mm aluminium grommets

Access grommet

Cat. No. 0893 07

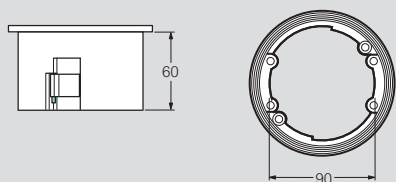

13 A power grommet

Cat. Nos. AM1B / AM1C

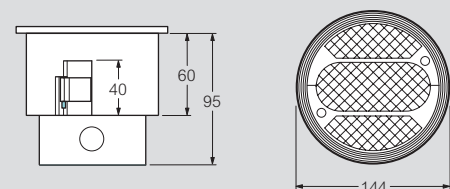

■ 250 mm grommet

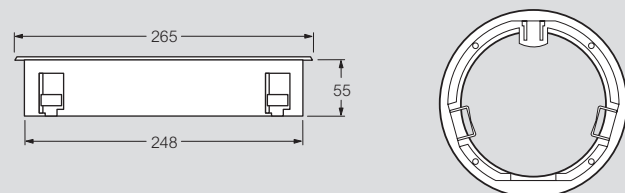

Cat. No. LSG2

Loading data

Load tests carried out to two standards BS EN (IEC) 61534 and BS EN (IEC) 50085

All tests performed in accordance to the above standards

Grommets :

Small area (point load¹) – 1.5 kN

Large area (plate²) – 3.0 kN

1 : Point load test = 13.3 mm diameter

2 : Plate load test = 130.0 mm diameter

All dimensions (mm) are nominal

IP 66 floor boxes



for raised or concrete floors

Product modules included in images Cat. Nos. 0880 61/64 are for illustrative purposes only

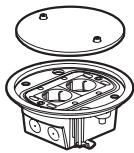

Technical characteristics visit www.legrand.co.uk

Conform to IEC / BS EN 60670-23

Pack	Cat.Nos	IP 66 floor boxes
1	0880 61	<p>Supplied with lid and 4 module support frame for Arteor modules To be installed in flush mounting back box Cat.No. 0880 69 or directly in raised floor Overall Ø 170 mm IK 09 with the lid closed Resistance to loads with lid closed: 10000 N</p> <p>With removable lid - for indoor and outdoor use Can be equipped with cable exit accessory Cat.No. 0880 62 IP 66 (when lid is closed) IP 54 (with cable exit accessory Cat.No. 0880 62 and plugs inserted into the sockets) Stainless steel finish</p> 
1	0880 64	<p>With hinged lid - for indoor use Compatible with angled plugs only Can be equipped with key lock on request contact us on +44 (0) 345 605 4333 IP 66 (when lid is closed) Stainless steel finish</p> 
1	0880 69	<p>Flush mounting back box Auto-adjustable back box for installing IP 66 floor boxes in concrete floors Supplied with cover Accepts conduits Ø16, 20, 25 mm Minimum screed height: 65 mm</p>
1	0880 62	<p>Cable exit accessory For removable lid weatherproof floor boxes Cat.No 0880 61 Allows the passage of power cords when plugs are inserted into the sockets inside the floor box Compatible with angled plugs only IP 54 (when plugs inserted into the sockets)</p>

For information on Arteor modules see Wiring accessories product guide or visit **Legrand's website** www.legrand.co.uk



SOLUFLEX[®]

innovative cable management flooring

Soluflex is much more than just a raised floor, it's a quick and simple to install cable management solution.

This innovative system integrates low-level flooring with Legrand's market leading cable management ranges, allowing cables for power, data and communication to be structured in a logical, ready to use layout that remains hidden to end users.

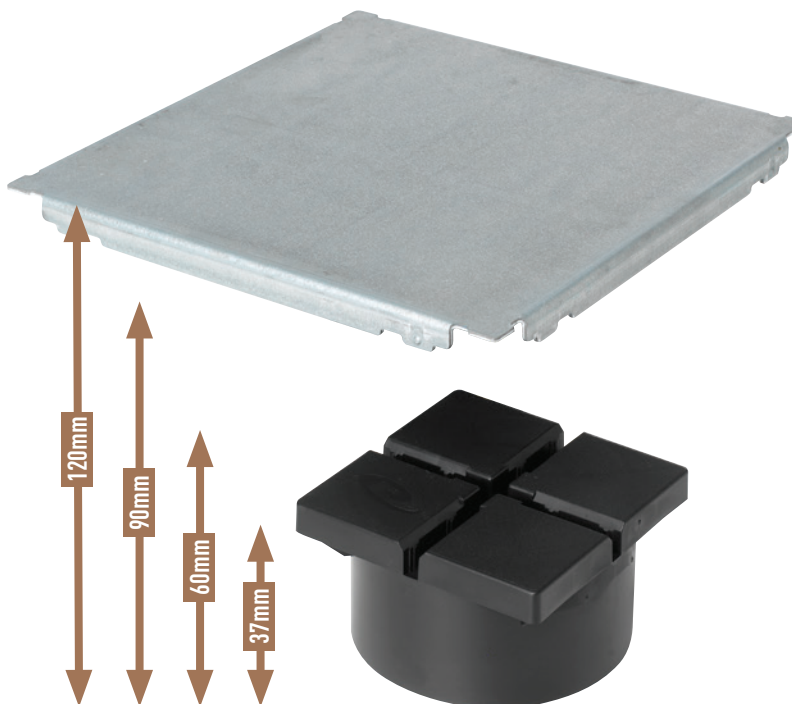
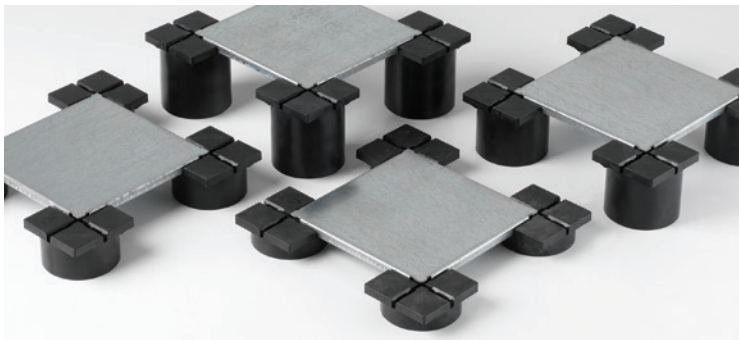

NEW SIZES ALSO AVAILABLE - 50, 70, 80 and 150mm
Contact us on: +44 (0) 370 608 9020

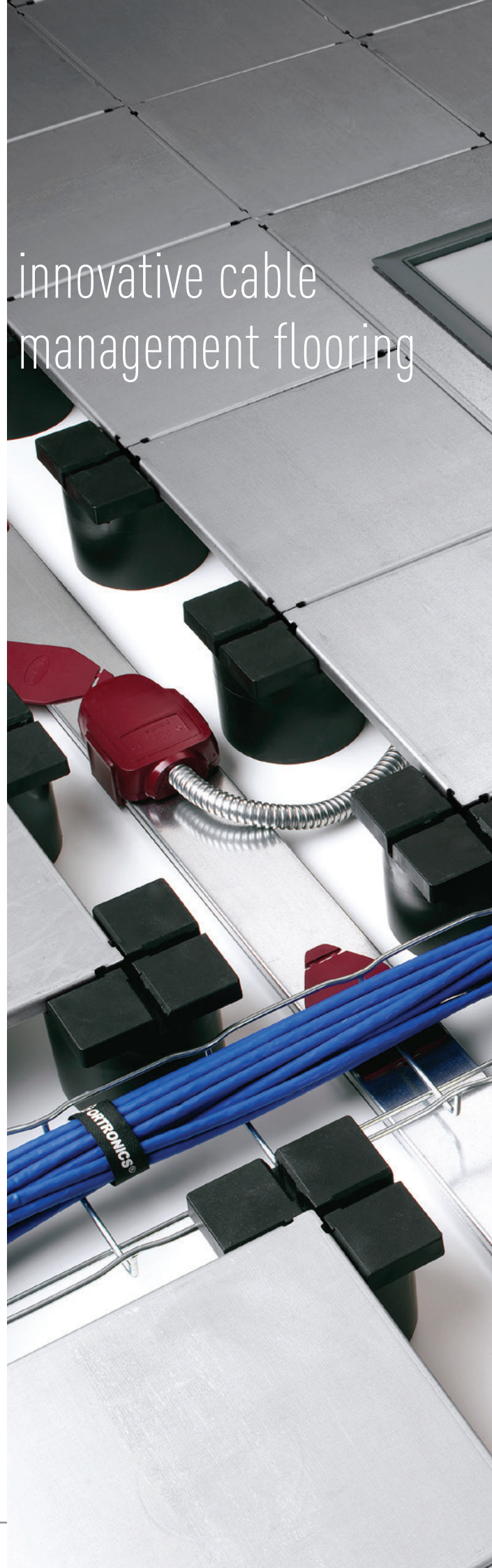

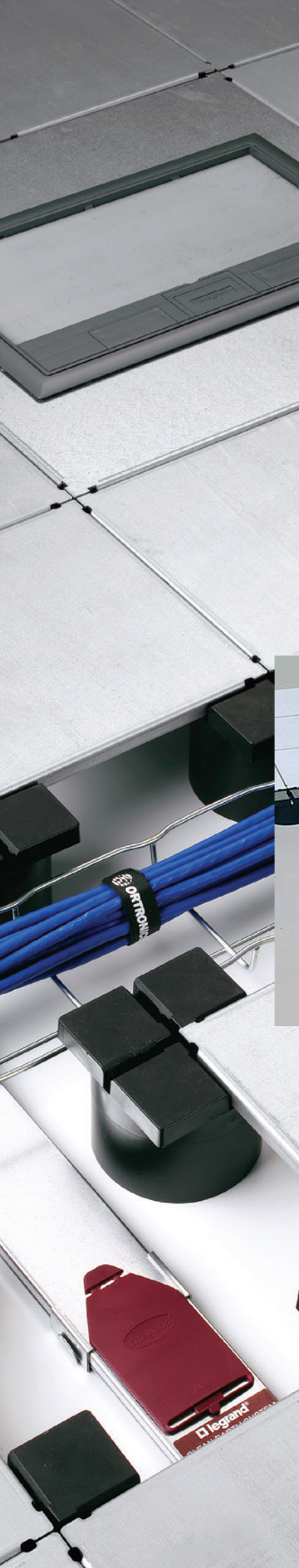

PERFECT PARTNERS

Soluflex has been designed to integrate perfectly with Legrand's market leading cable management ranges and wiring accessories...

From ultra-compact Electrak floor systems to Cablofil® steel wire cable tray, and from cavity floor boxes to Arteor power and data sockets, every solution can be installed in or under the floor using Soluflex.

QUICK AND EASY INSTALLATION

You don't have to be a flooring expert to install Soluflex. It's simply a question of placing supports on the floor and then clicking the durable steel tiles into place (without the need for glue or fixings).



Once the floor has been laid, the required cabling and connections can be installed between the supports by removing the relevant tiles until cabling is complete. The finished installation can then be covered with any type of covering... carpet tiles, rubber, stone or wood. And if the office layout changes, or even relocates, Soluflex can be reconfigured and reused.

IDEAL FOR RENOVATION

Ideal for use in existing buildings, Soluflex's non-invasive installation technique avoids damaging historic floors and includes a specially developed, ultra low 37 mm system... the perfect lightweight solution to bring older buildings into the 21st century without compromising floor to ceiling height.

Soluflex® cavity floor system

selection chart

Height (mm)	Tile	Support	Double edge plate	Single edge plate	Step	Step corner	Ramp
37	84000 10	84037 00	84000 60	84000 61	84037 22	84037 30	84037 40
60	84000 10	84060 00	84000 60	84000 61	84060 22	84060 30	84060 40
90	84000 10	84090 00	84000 60	84000 61	84090 22	84090 30	84090 40
120	84000 10	84120 00	84000 60	84000 61	84120 22	84120 30	84120 40

Height (mm)	Floor box tile	Floor box lid + trim	3 comp. twin socket module	4 comp. twin socket module	3 comp. blank module	4 comp. blank module
37	-	-	-	-	-	-
60	84090 81	8218 21	8218 22	8218 23	8218 24	8218 25
90	84090 81	8218 21	8218 22	8218 23	8218 24	8218 25
120	84090 81	8218 21	8218 22	8218 23	8218 24	8218 25





1 : For use with accessory outlet tile or cable outlet tile
 2 : For use with accessory outlet tile. Standard version shown. Requires back box, Cat. No. 8218 30. Other configurations available to special order.
 Contact us on +44 (0) 370 608 9020

■ Floor boxes with lid and trim assemblies :

Suitable for 60, 90 and 120 mm systems

Specials also available, including RCD and RCBO options to comply with 17th Edition requirements

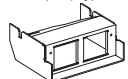
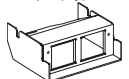

	Earthing tile	Cable outlet tile	Chrome outlet grommet	Semi-submerged power unit 2 x 240 V (empty)	Semi-submerged data unit 2 x 2 data (empty)	Fully submerged power unit 2 x 240 V (empty)	Fully submerged data unit 2 x 2 data (empty)
							
	84000 20	84000 30	81902 32	84037 50	84037 51	-	-
	84000 20	84000 30	81902 32	-	-	84060 72	84060 73
	84000 20	84000 30	81902 32	-	-	-	-
	84000 20	84000 30	81902 32	-	-	-	-

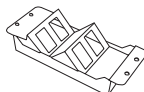
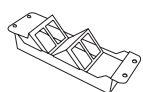
	3 comp. data module	4 comp. data module
		
	-	-
	8218 26	8218 27
	8218 26	8218 27
	8218 26	8218 27



Now also available in 50, 70, 80 and 150 mm heights

Contact us on +44 (0) 370 608 9020

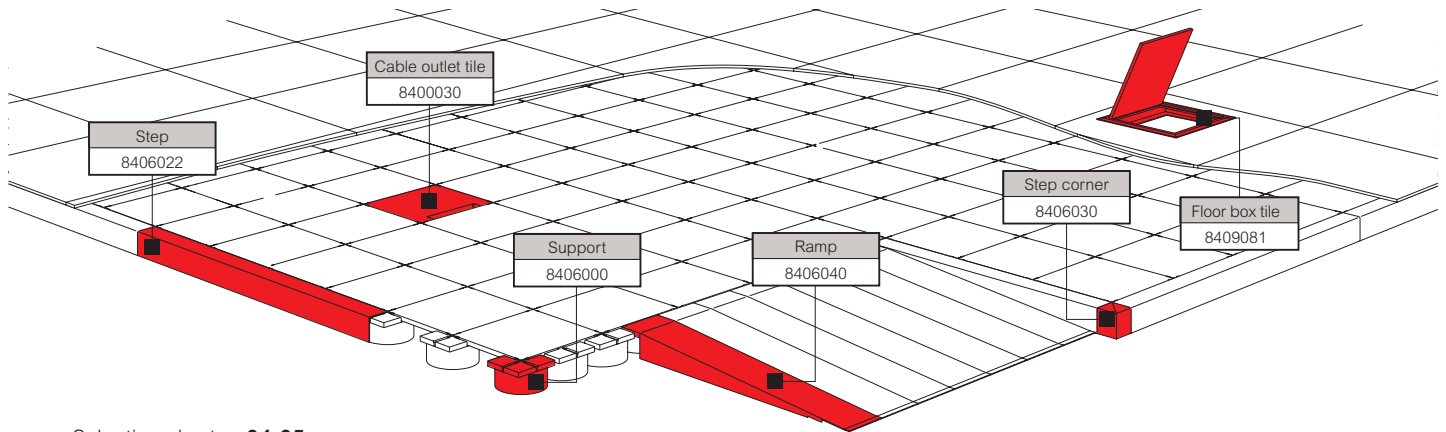

Selection chart **p. 34-35**
 Installation instructions **p. 39**
 Dimensions **p. 40-41**

Cable management floor system
 225 x 225 mm tiles manufactured from pre-galvanised steel with
 13 mm return
 Integrated earthing design
 Click fit, no fixings required
 Supports manufactured from recycled polypropylene

Pack Cat. Nos. Floor components

Pack	Cat. Nos.	Description	Image
1	8400010	Tile 225 x 225 mm floor tile	
1	8403700	Floor supports 37 mm height (35 mm support – 37 mm inc. tile)	
1	8406000	60 mm height (58 mm support – 60 mm inc. tile)	
1	8409000	90 mm height (88 mm support – 90 mm inc. tile)	
1	8412000	120 mm height (118 mm support – 120 mm inc. tile)	
1	8400020	Earthing tile 225 x 225 mm Earthing clamp 6 mm ² (max.) 1 earthing tile per 100 m ²	
1	8400060	Edge plates Used to finish installation against wall Trim to size on site 900 x 300 mm double edge plate	
1	8400061	900 x 300 mm single edge plate	
1	8403722	Step Width 900 mm Height (mm) 37	
1	8406022	60	
1	8409022	90	
1	8412022	120	

Pack Cat. Nos. Floor components (continued)

Pack	Cat. Nos.	Description	Image
1	8403730	Step corner Width 900 mm Height (mm) 37	
1	8406030	60	
1	8409030	90	
1	8412030	120	
1	8403740	Ramp 10% incline Height (mm) 37	
1	8406040	60	
1	8409040	90	
1	8412040	120	

Now also available in 50, 70, 80 and 150 mm heights
Contact us on +44 (0) 370 608 9020

Soluflex®

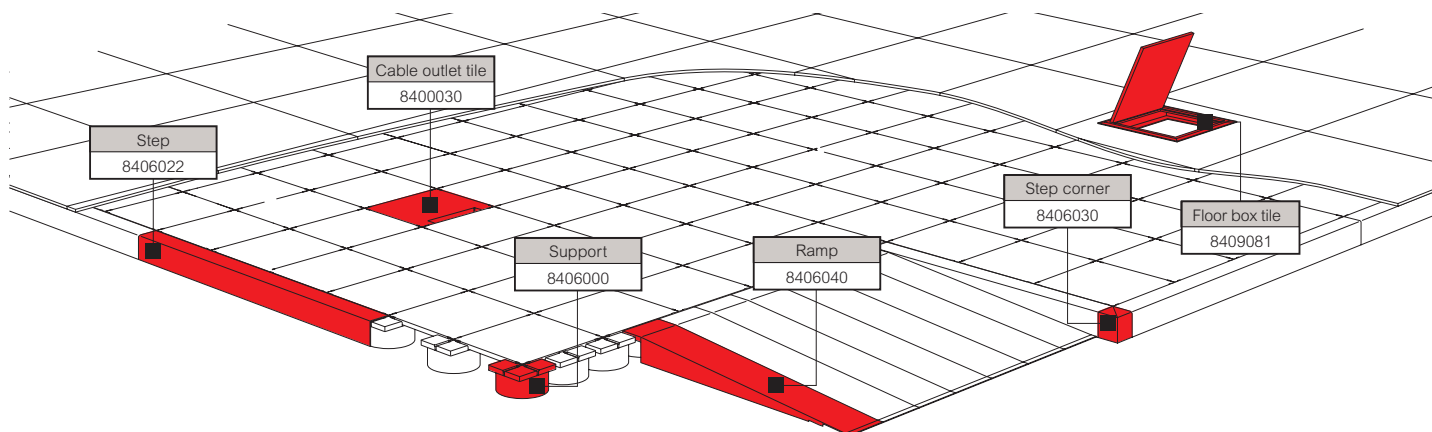

ultra low cavity floor system (continued)





 Selection chart **p. 34-35**
 Installation instructions **p. 39**
 Dimensions **p. 40-41**

Cable management floor system
 225 x 225 mm tiles manufactured from pre-galvanised steel with
 13 mm return
 Integrated earthing design
 Click fit, no fixings required
 Supports manufactured from recycled polypropylene

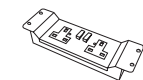
Pack	Cat. Nos.	Floor box for 60, 90 and 120 mm high systems only
1	8409081	Floor box 450 x 450 mm floor box tile
1	821821	Floor box lid and trim
Outlet plate options		
1	821822	3 compartment twin switched socket module
1	821824	3 compartment blank module
1	821826	3 compartment data module (4 x 37 x 22 mm cut-outs)
1	821823	4 compartment twin switched socket module
1	821825	4 compartment blank module
1	821827	4 compartment data module (4 x 37 x 22 mm cut-outs)

1	8409081	Floor box 450 x 450 mm floor box tile	
1	821821	Floor box lid and trim	
Outlet plate options			
1	821822	3 compartment twin switched socket module	
1	821824	3 compartment blank module	
1	821826	3 compartment data module (4 x 37 x 22 mm cut-outs)	
1	821823	4 compartment twin switched socket module	
1	821825	4 compartment blank module	
1	821827	4 compartment data module (4 x 37 x 22 mm cut-outs)	

Pack	Cat. Nos.	Universal outlets
1	8190232	Accessories Chrome outlet grommet
1	8400030	Cable outlet tile

1	8190232	Accessories Chrome outlet grommet	
1	8400030	Cable outlet tile	

Outlet solutions for 37 mm high systems

Pack	Cat. Nos.	Semi-submerged
1	8403750	37 mm power outlet to accept 2 x Arteor double modules ¹
1	8403751	37 mm data outlet to accept 2 x Arteor double modules ¹

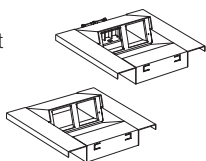

Outlet solutions for 60 mm high systems

Pack	Cat. Nos.	Fully submerged
1	8406072	60 mm power outlet to accept 2 x Arteor double modules ¹
1	8406073	60 mm data outlet to accept 2 x Arteor double modules ¹

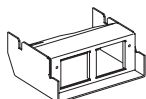

1: For Arteor modules, refer to the latest Wiring Devices catalogue

Soluflex® cavity floor system

technical information

■ Specification / technical data

Construction

The Soluflex cable floor system is constructed of a raised floor of tiles and supports with integrated cabling and connection points for telecoms, power and data

Materials

- The tiles are manufactured from pre-galvanised sheet steel in accordance with BS EN 10346
- The supports are made of polypropylene. Inflammability class B2 according to DIN 4102

Weights and measures

- Dimensions of tiles : 225 x 225 mm
- 4 different heights : 37 mm, 60 mm, 90 mm, 120 mm
Other heights available on request (50, 70, 80 and 150 mm)
- Weight of the Soluflex cable floor system : approx. 20 kg per m²

■ Load bearing data

- Point load per tile/support : 1 500 Newton/25 mm²
- Equal divided load of 3 000 kg per m²
- Minimum safety factor : V = 1.71

■ Sound measurements

The sound measurements have been carried out in the laboratory of consultancy firm Peutz & Associates. The complete report can be obtained from our sales department

Acoustic

• Flanking airborne sound insulation in accordance with ISO 717-1 : 1996

Tested according to ISO 140-12 : 2000

Soluflex cable floor system + carpet tiles, without mineral wool underneath the partition wall : Dn,f,w = 48 dB

Soluflex cable floor system + carpet tiles, with mineral wool underneath the partition wall : Dn,f,w = 48 dB

• Flanking impact sound insulation in accordance with ISO 717-2 : 1996

Tested in accordance to ISO 140-12 : 2000

Soluflex cable floor system + carpet tiles, without mineral wool underneath the partition wall : Ln,f,w = 49 dB

Soluflex cable floor system + carpet tiles, with mineral wool underneath the partition wall : Ln,f,w = 39 dB

• Vertical impact sound insulation improvement in accordance with ISO 717-2 : 1996

Tested in accordance with ISO 140-8 : 1978

Concrete floor 140 mm + Soluflex

□Lw = 17 dB □Iln = 7 dB

Concrete floor 140 mm + Soluflex + carpet tiles

□Lw = 24 dB □Iln = 12 dB

Tested to : PSA MOB PF2PS/SPU

BS EN 12825 : 2001

Working load : 1.9kN

Ultimate load above 12kN	Deflection under working load	Safety factor	Class of tolerance in manufacture
1	A	3	1

Working load : 2.9kN

Ultimate load above 12kN	Deflection under working load	Safety factor	Class of tolerance in manufacture
1	B	2	1

■ Safety

- Safety against short circuits : Soluflex is earthed (as long as 1 earthing tile is installed per 100 m²)
- Fire resistance : due to its low plenum height Soluflex is self-extinguishing
Tested according to BS EN 13501-1, class B(fl)S1-d0

Other characteristics

The Soluflex cable floor system feels extremely solid. Since the system is not adjustable in height, it needs no later adjustment
The grid layout of the system means the cables are perfectly parallel, and you can cross data cables at the required angle of 90°

■ TNO-fire

Fire propagation

Its low plenum height enables the cable floor system to be self-extinguishing

NEN-EN 13501-1

B(fl) S1-d0

NEN 1775 :

A – Inflammability – complies with the class T1 criteria for inflammability

B – Horizontal fire propagation : all heights
maximum horizontal fire propagation = 0 cm, which implies a critical density of heat flow of more than 11 kW/m²
Classification according to NEN 1775 : Class T1

NEN 6066 :

With (highest) heat flow supply of 50 kW/m² :

(highest) normative smoke density smaller than 0.5 m-1, which is very little smoke production in case of fire

DIN 4102 :

Resistance to fire in accordance with DIN 4102 Class B1

■ Level floor

The sub-floor must be dry, clean and level, suitable for laying carpet. If the floor is not level, it must be levelled before you start to install the Soluflex cable floor system. Please contact your floor specialist for professional advice

■ KEMA-certificate

Soluflex cable floor system has been certified by KEMA and meets the requirements for mechanical and electrical safety

Earthing

The cable floor system is automatically earthed, provided that 1 earthing tile is installed per 100 m². Install an earthing tile every 14 m length in gangways



Soluflex[®] cavity floor system

general installation instructions

■ Installing the Soluflex cable floor system

- Start with a dry, clean and level sub-floor that is suitable for laying normal carpet. If the floor does not meet these requirements, level it first
- Start in the corner of the room and click the tiles into the plastic supports. Leave a 10 mm gap between the wall and tile to allow for expansion. Continue to build the floor like this and cut fitting tiles or edge plates to size
- You are now ready to open the cable routes using your cabling plan. Make sure that the cables are not placed under proposed locations of filing cabinets or other furniture as this limits flexibility
- The corners of the tiles have small recesses to enable them to be lifted using a screwdriver. Once one tile has been removed, the others can be removed by hand
- Now place the power track or cables into the cable routes, taking into account any extra cabling requirements for future flexibility
- By installing more outlet boxes you will be able to create extra connections without interruption later
- Dependent on the floor height being installed, a choice can be made from various (pre-wired) outlet units in or on the cable floor
- Earth the cable floor system every 100 m² by means of an earthing tile
- In stretched areas such as corridors, place an earthing tile at least every 14 metres
- The electrical installation should always be carried out by a qualified electrician in conjunction with the requirements of the latest wiring regulations
- To create 'islands', install steps with step corners to ensure a neat finishing of the system
- The ramp provides a constant transition from an existing floor to the Soluflex cable floor system
- The entire system can easily be dismantled and installed again as required, giving Soluflex a virtually unlimited life
- The finished installation can then be covered with rubber, stone, wood or carpet tiles
- Finishing with carpet tiles is advised for true flexibility and accessibility of the system

Ramp



Cable routes



Completed Soluflex installation



Finished example with carpet tiles

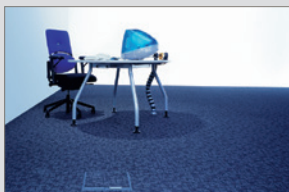

Soluflex® cavity floor system

37 mm, 60 mm, 90 mm, 120 mm height

■ Dimensions (mm)

Tile

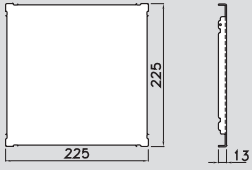

Cat. No. 8400010

Supports

For 37 mm height

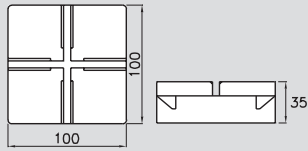

Cat. No. 8403700

For 60 mm height

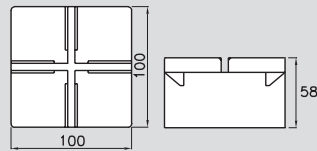

Cat. No. 8406000

For 90 mm height

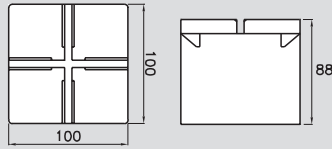

Cat. No. 8409000

For 120 mm height

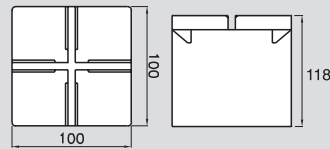

Cat. No. 8412000

Double edge plate

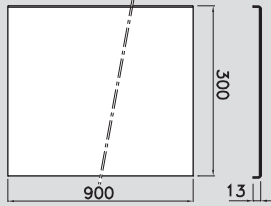

Cat. No. 8400060

Single edge plate

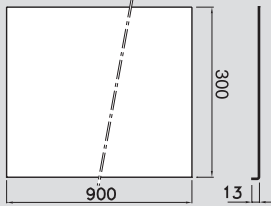

Cat. No. 8400061

Steps

For 37 mm height

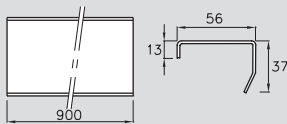

Cat. No. 8403722

For 60 mm height

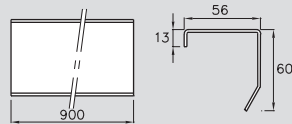

Cat. No. 8406022

For 90 mm height

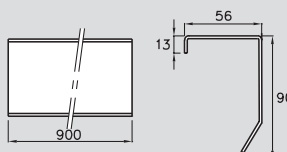

Cat. No. 8409022

For 120 mm height

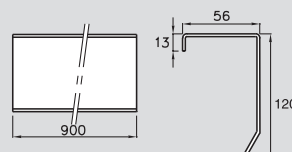

Cat. No. 8412022

Step corner

For 37 mm height

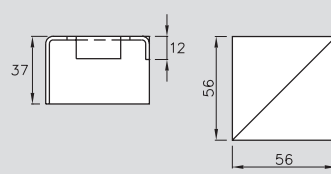

Cat. No. 8403730

For 60 mm height

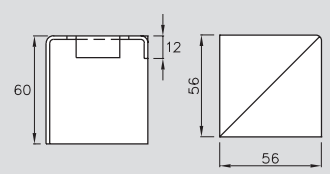

Cat. No. 8406030

For 90 mm height

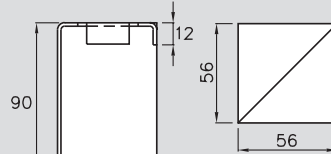

Cat. No. 8409030

For 120 mm height

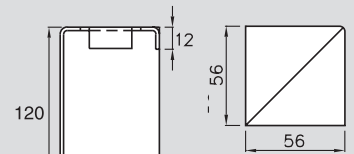

Cat. No. 8412030

Ramp

For 37 mm height

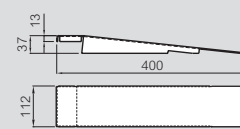

Cat. No. 8403740

For 60 mm height

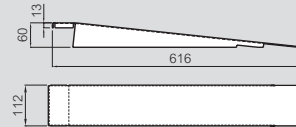

Cat. No. 8406040

For 90 mm height

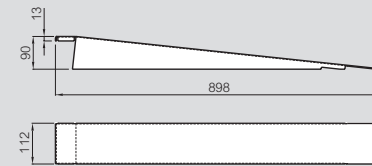

Cat. No. 8409040

For 120 mm height

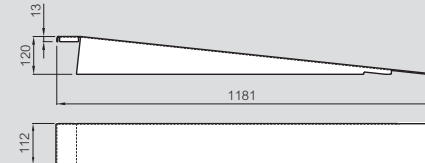

Cat. No. 8412040

All dimensions (mm) are nominal

Soluflex[®] cavity floor system

37 mm, 60 mm, 90 mm, 120 mm height (continued)

Dimensions (mm)

Earthing tile

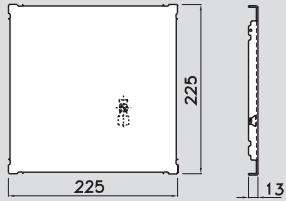

Cat. No. 8400020

Cable outlet tile

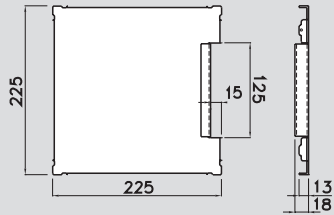

Cat. No. 8400030

Chrome outlet grommet

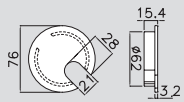

Cat. No. 8190232

Semi-submerged unit

For 37 mm range only

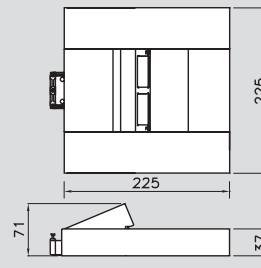

Cat. Nos. 8403750 Power
8403751 Data

Fully submerged power unit 2 x 240 V (empty)

For 60 mm range only

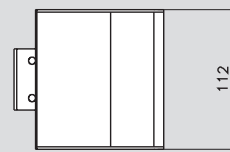

Cat. No. 8406072

Fully submerged data unit 2 x 2 data (empty)

For 60 mm range only

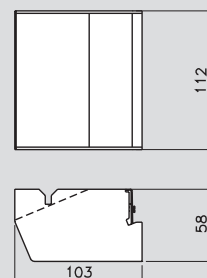

Cat. No. 8406073

Floor box tile

For 60 mm, 90 mm, 120 mm ranges only

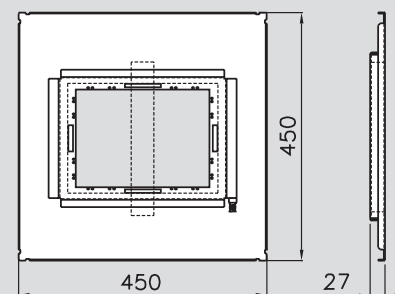

Cat. No. 8409081

All dimensions (mm) are nominal

FLOOR SYSTEMS

making the
right choice
simple

With a large choice of flush and in-screed solutions available in a variety of sizes, Legrand has all your cable management floor system requirements covered.

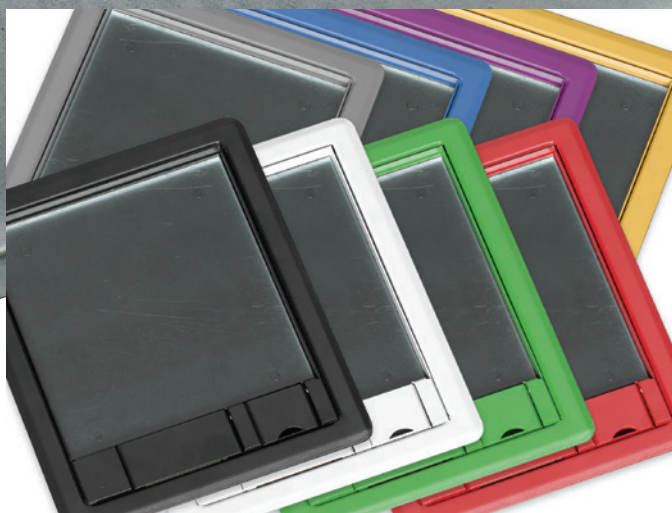
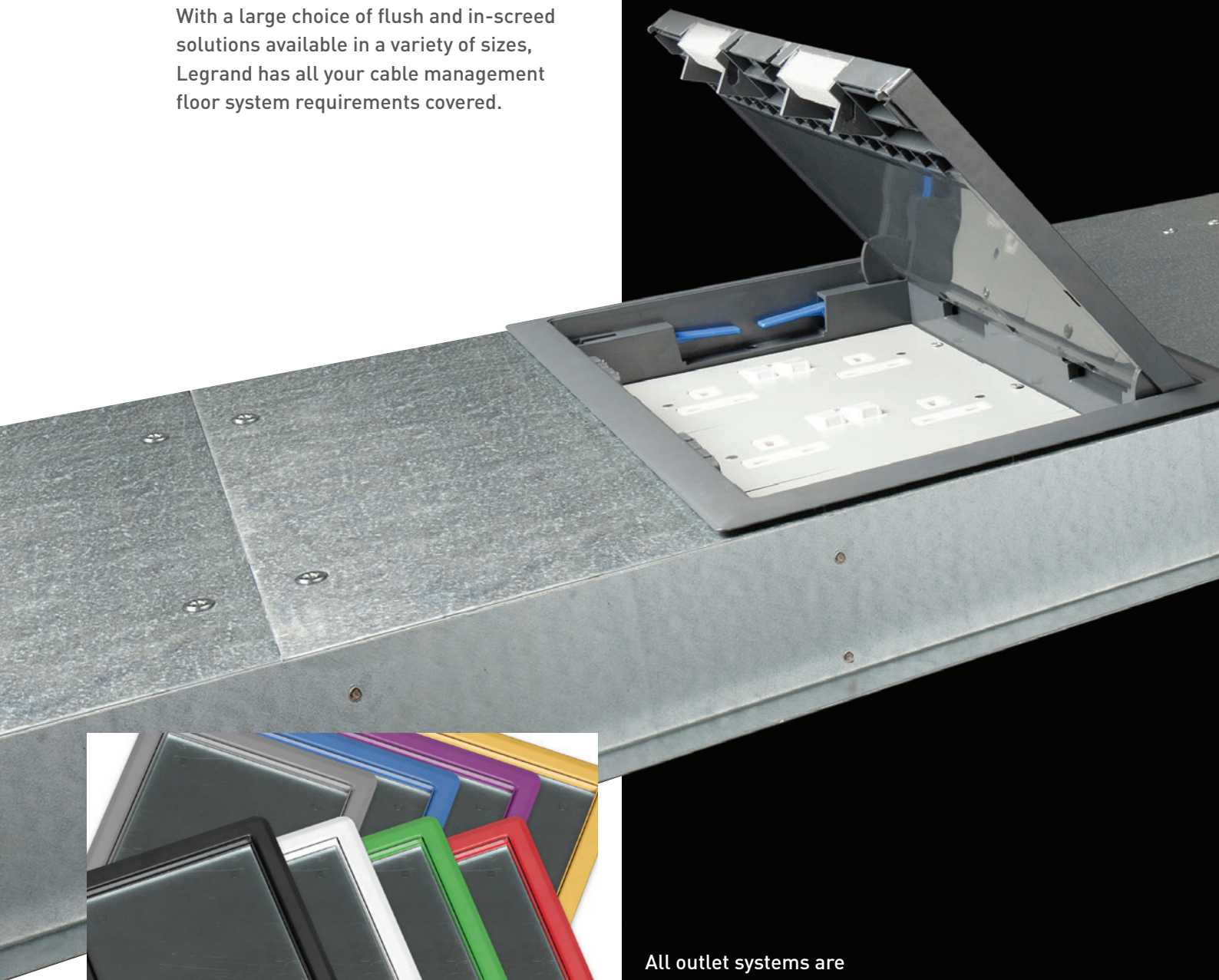

All outlet systems are designed to accept a wide range of mix and match lids and trims.

Bespoke metal trims are available in any RAL reference to suit a building's design scheme.

PRODUCT RANGES

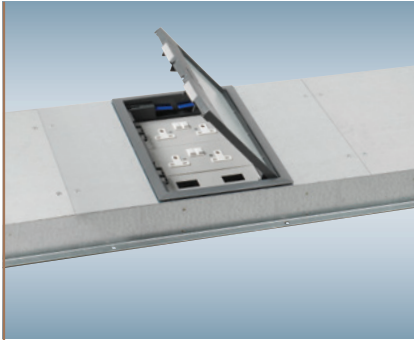

FLUSH FLOOR TRUNKING

- Commercial floor trunking system
- Ideal for distributing power, data and communication in any commercial environment
- Can be used if service outlets are required
- Cables can be accessed after installation has been completed
- Floor boxes can be positioned at any point along the trunking and removed and repositioned at a later date

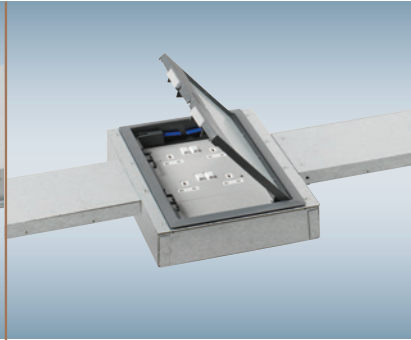

SHALLOW FLUSH FLOOR TRUNKING

- Commercial floor trunking system
- Designed to distribute power, data and communication where the amount of screed that can be removed is limited
- Can be used if service outlets are required
- Cables can be accessed after installation has been completed

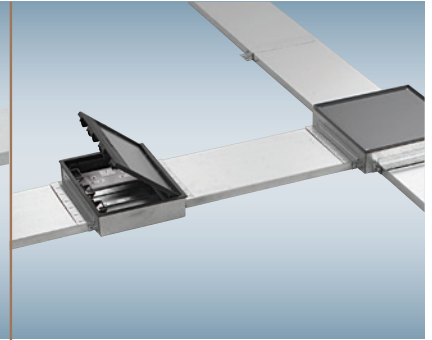

UNDERFLOOR DUCT

- Commercial floor ducting system
- Ducting is installed under the screed providing a strong yet cost effective solution
- Position of service outlet and junction boxes is fixed prior to installation
- Service outlet and junction boxes are height adjustable to fit flush with screed

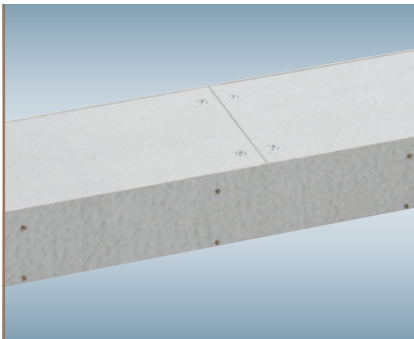

FLUSH LID FLOOR TRUNKING

- Commercial floor trunking system
- Floor finish is fitted over the flush lid giving a neat finish
- Available in a wide range of sizes
- Suitable for long runs of cable where no outlets are required

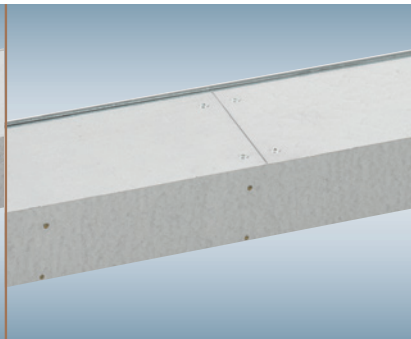

RECESSED LID FLOOR TRUNKING

- Commercial floor trunking system
- Floor finish is fitted recessed into the trunking lid
- Suitable for use in environments where access to cables may be required at a later date, for example hospitals

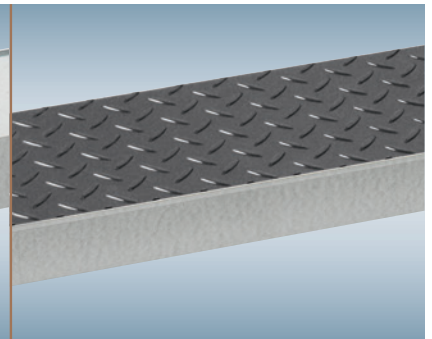

CHEQUER PLATE FLOOR TRUNKING

- Industrial floor trunking system
- Outward return flange for added strength
- Suitable for floors that are subjected to heavy loads, for example warehouses

commercial floor trunking systems

flush floor trunking

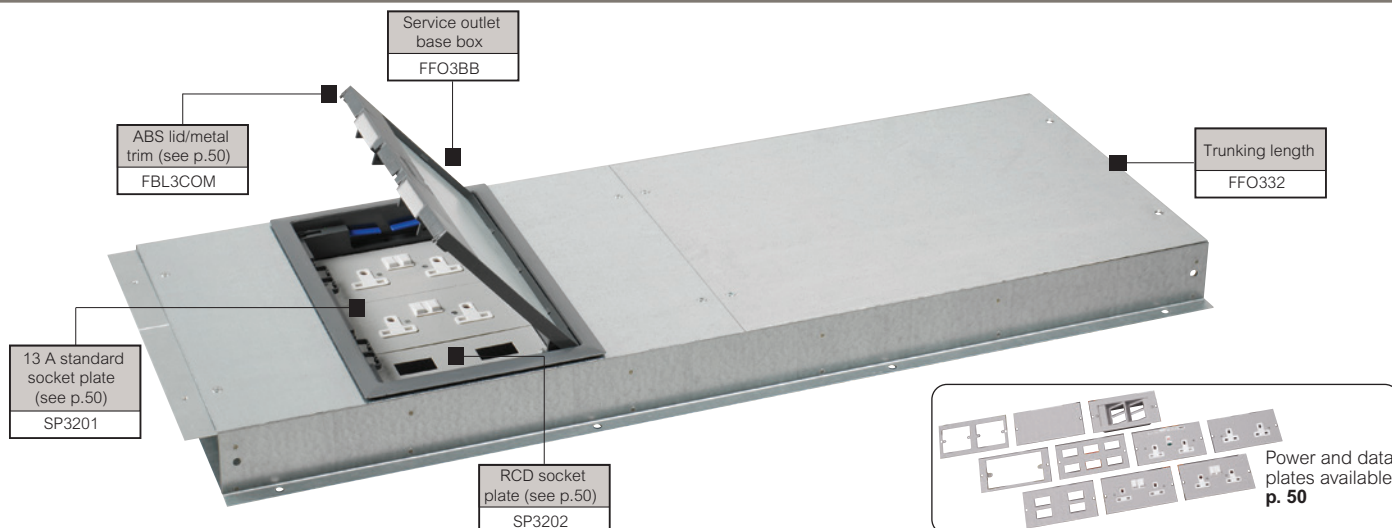

Screed floor outlet boxes selection chart p. 48-49
Dimensions and technical information p. 53
Installation details p. 55

Body and lid manufactured from pre-galvanised sheet steel to BS EN 10346
 Standard lengths : trunking 2.0 m, lid 0.5 m
 Standard lid thickness : 2.5 mm
 Each 2 m length is fitted with 4 x 500 mm long lids and supplied complete with all necessary connectors and screws
 Trunking to floor fixings not supplied
 A service outlet floor box can be fitted at each lid position

Pack	Cat. Nos.	Flush floor trunking	
1	3 comp FFO332 4 comp FFO342	Trunking length – 2 m 370 x 65 mm	
1	FFO330	Spare connector set 370 x 65 mm	
1	3 comp FFO3311 4 comp FFO3411	90° riser bend Supplied with screeding cover Provides conduit entry with 20 mm knockouts 370 x 65 mm	
1	3 comp FFOS3SK6 4 comp FFOS4SK6	Back entry skirting adaptor 370 x 65 – 150 mm high skirting 370 x 65 – 200 mm high skirting	
1	FFOS3SK8 FFOS4SK8		
1	3 comp FFOT332T 4 comp FFOT342T	Cable trunking adaptor 370 x 65 mm To complete the Cat. No. specify : T = standard cable trunking Cat. No. Example : FFOT 332 MGR623C	

Pack	Cat. Nos.	Flush floor trunking (continued)	
1	FFO3312	End cap 370 x 65 mm	
1	3 comp FFO3313 4 comp FFO3413	Junction box Supplied with connections and blanking plates Can be configured as a fourway, tee, bend or straight through connector box 370 x 65 mm	
1	3 comp FFO3BB 4 comp FFO4BB	Service outlet base boxes Service outlet base boxes are supplied fitted into a 500 mm long cover To complete the system, the outlet base box requires outlet plates, lid and trim Outlet plates, lids and trims ordered separately, (see p. 50)	

Flush floor trunking can be supplied in widths and depths greater than 370 x 65 mm to special order
Contact us on +44 (0) 370 608 9020

All trims for service outlet boxes can be ABS, stainless steel, brass or powder coated any colour **p. 50**

commercial floor trunking systems

shallow flush floor trunking

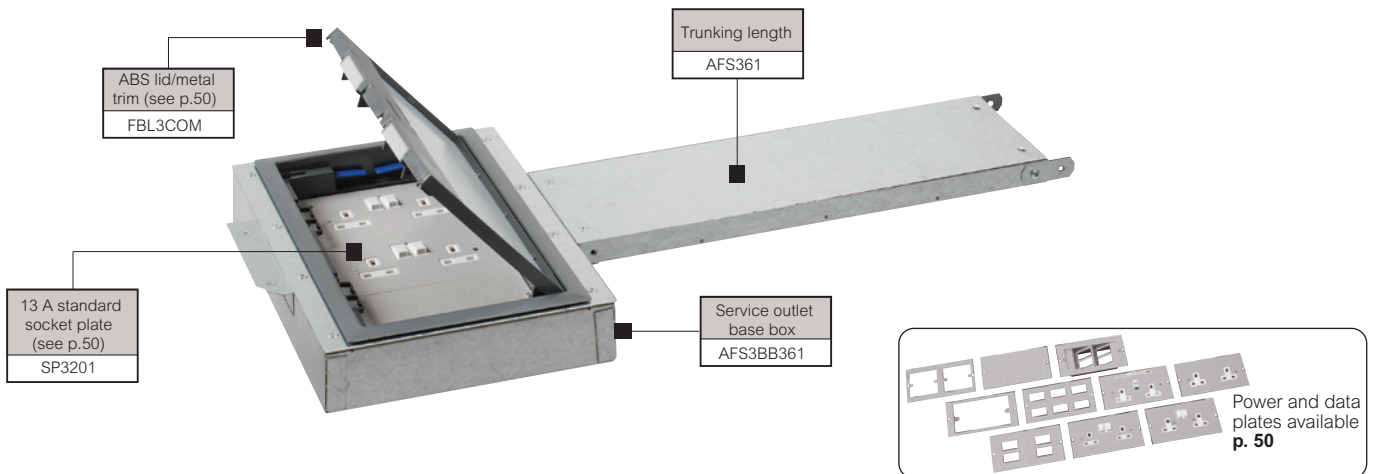

Screed floor outlet boxes selection chart p. 48-49
Dimensions and technical information p. 53
Installation details p. 55

Body and lid manufactured from pre-galvanised sheet steel to BS EN 10346

Standard lengths : trunking 2.0 m, lid 0.5 m

Standard lid thickness : 2.5 mm

Each 2 m length is fitted with 4 x 500 mm long lids and supplied complete with all necessary connectors and screws

Pack	Cat. Nos.	Shallow flush floor trunking	
		Trunking length – 2 m	
1	2 comp AFS261	3 comp AFS361	150 x 25 mm
1	AFS265	AFS365	150 x 38 mm
1		AFS391	225 x 25 mm
1		AFS395	225 x 38 mm
		Spare connector set	
1	AFS3611		150 mm wide
1	AFS3911		225 mm wide
		90° riser bend	
		Supplied with screeding cover Provides conduit entry with 20 mm knockouts	
1	2 comp AFS2613	3 comp AFS3613	150 x 25 mm
1	AFS2653	AFS3653	150 x 38 mm
1		AFS3913	225 x 25 mm
1		AFS3953	225 x 38 mm
		Back entry skirting adaptor	
1	AFSSFSKS	To complete the Cat. No. specify : F = shallow flush floor trunking size code S = skirting trunking height in inches Example : AFSS 361 SK6	
		Cable trunking adaptor	
1	AFSTFT	Supplied with turnbuckle fix lid To complete the Cat. No. specify : F = shallow flush floor trunking size code T = standard cable trunking Cat. No. Example : AFST 361 MGR623C	

Pack	Cat. Nos.	Shallow flush floor trunking (continued)	
		End cap	
1	AFS2615		150 x 25 mm
1	AFS2655		150 x 38 mm
1	AFS3915		225 x 25 mm
1	AFS3955		225 x 38 mm
		Junction box	
		Supplied with connections and blanking plates Can be configured as a fourway, tee, bend or straight through connector box	
1	2 comp AFS2614	3 comp AFS3614	150 x 25 mm
1	AFS2654	AFS3654	150 x 38 mm
1		AFS3914	225 x 25 mm
1		AFS3954	225 x 38 mm
		Service outlet base boxes	
		Service outlet base boxes are supplied empty Service outlet boxes are 65 mm deep Due to shallow depth of trunking, box locations need to be defined and recessed locally before installation To complete the system, the outlet base box requires outlet plates, lid and trim Outlet plates, lids and trims ordered separately, (see p. 50)	
1	2 comp AFS2BB261	3 comp AFS3BB361	To suit 150 x 25 mm trunking
1	AFS2BB265	AFS3BB365	To suit 150 x 38 mm trunking
1		AFS3BB391	To suit 225 x 25 mm trunking
1		AFS3BB395	To suit 225 x 38 mm trunking
		Service outlet base boxes (continued)	
1	4 comp AFS4BB261		To suit 150 x 25 mm trunking
1	AFS4BB265		To suit 150 x 38 mm trunking
1	AFS4BB361		To suit 150 x 25 mm trunking
1	AFS4BB365		To suit 150 x 38 mm trunking
1	AFS4BB391		To suit 225 x 25 mm trunking
1	AFS4BB395		To suit 225 x 38 mm trunking

Shallow flush floor trunking can be supplied in different widths and depths

Contact us on +44 (0) 370 608 9020

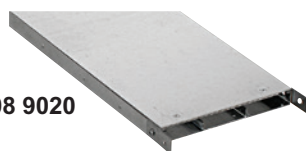

All trims for service outlet boxes can be ABS, stainless steel, brass or powder coated any colour **p. 50**



commercial floor trunking systems

underfloor duct

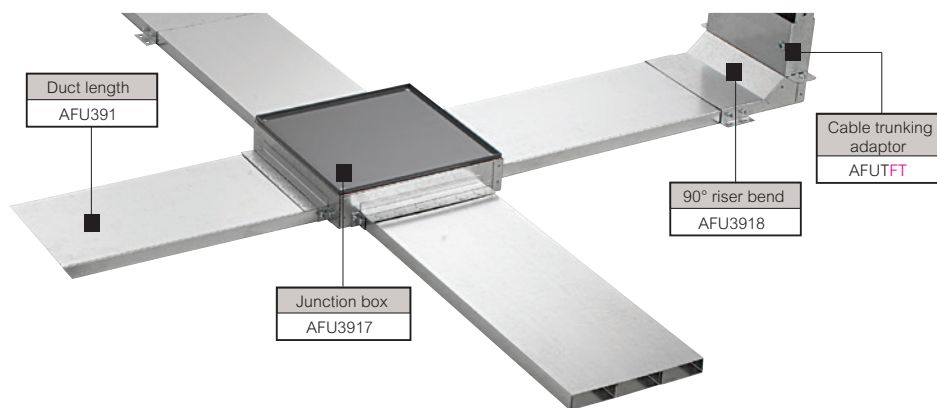

Screed floor outlet boxes selection chart **p. 48-49**
 Dimensions and technical information **p. 54**
 Installation details **p. 55**

Body and lid manufactured from pre-galvanised sheet steel to BS EN 10346
 Standard length : 2.0 m. Standard lid thickness : 1.0 mm
 Each 2 m length is supplied with 2 saddle clamps and screws
 Duct to floor fixings are not supplied

Pack	Cat. Nos.	Underfloor duct
Duct length – 2 m		
1	2 comp AFU261	150 x 25 mm
1	3 comp AFU361	150 x 38 mm
1	2 comp AFU265	225 x 25 mm
1	3 comp AFU365	225 x 38 mm
1	2 comp AFU391	225 x 25 mm
1	3 comp AFU395	225 x 38 mm
1	2 comp AFU311	300 x 25 mm
1	3 comp AFU315	300 x 38 mm
Spare saddle clamp		
1	AFU2612	150 x 25 mm
1	AFU2652	150 x 38 mm
1	AFU3912	225 x 25 mm
1	AFU3952	225 x 38 mm
1	AFU3112	300 x 25 mm
1	AFU3152	300 x 38 mm
90° flat bend		
1	2 comp AFU2613	150 x 25 mm
1	3 comp AFU3613	150 x 38 mm
1	2 comp AFU2653	225 x 25 mm
1	3 comp AFU3653	225 x 38 mm
1	2 comp AFU3913	225 x 25 mm
1	3 comp AFU3953	225 x 38 mm
1	2 comp AFU3113	300 x 25 mm
1	3 comp AFU3153	300 x 38 mm
90° riser bend		
Supplied with screeding cover Provides conduit entry with 20 mm knockouts		
1	2 comp AFU2618	150 x 25 mm
1	3 comp AFU3618	150 x 38 mm
1	2 comp AFU2654	225 x 25 mm
1	3 comp AFU3654	225 x 38 mm
1	2 comp AFU3918	225 x 25 mm
1	3 comp AFU3954	225 x 38 mm
1	2 comp AFU3118	300 x 25 mm
1	3 comp AFU3154	300 x 38 mm
Back entry skirting adaptor		
1	AFUSFSK S	To complete the Cat. No. specify : F = underfloor duct size code S = skirting trunking height in inches Example : AFUS 391 SK6
Cable trunking adaptor		
1	AFUTFT	Supplied with turnbuckle fix lid To complete the Cat. No. specify : F = underfloor duct size code T = standard cable trunking Cat. No. Example : AFUT 395 MGR623C

Pack	Cat. Nos.	Underfloor duct (continued)
End cap		
1	AFU2615	150 x 25 mm
1	AFU2655	150 x 38 mm
1	AFU3915	225 x 25 mm
1	AFU3955	225 x 38 mm
1	AFU3115	300 x 25 mm
1	AFU3155	300 x 38 mm
Junction box		
Can be configured as a fourway, tee, bend or straight through connector box When using with a conduit system, select junction box depending on conduit size For 20 mm conduit use junction box that would suit a 25 mm ducting For 25 mm conduit use junction box that would suit a 38 mm ducting		
To suit screed 65 mm to 80 mm deep		
1	2 comp AFU2617	150 x 25 mm
1	3 comp AFU3617	225 x 25 mm
1	3 comp AFU3917	225 x 38 mm
1	3 comp AFU3117	300 x 25 mm
To suit screed 75 mm to 90 mm deep		
1	2 comp AFU2656	150 x 38 mm
1	3 comp AFU3656	225 x 38 mm
1	3 comp AFU3956	225 x 38 mm
1	3 comp AFU3156	300 x 38 mm

Underfloor duct can be supplied in other widths, depths and compartment configurations to special order
Contact us on +44 (0) 370 608 9020

commercial floor trunking systems

underfloor duct (continued)

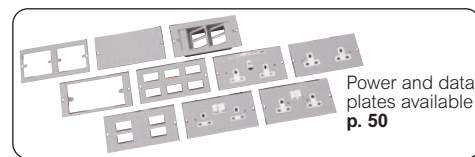
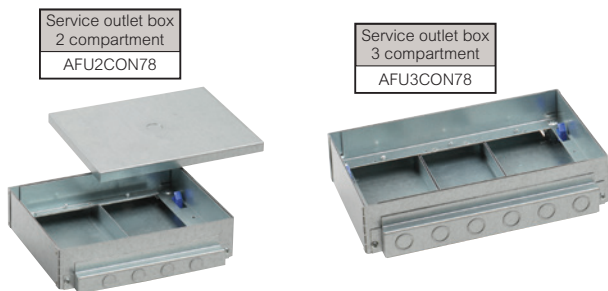

Sced floor outlet boxes selection chart **p. 48-49**
 Dimensions and technical information **p. 54**
 Installation details **p. 55**

Body and lid manufactured from pre-galvanised sheet steel to BS EN 10346
 Standard length : 2.0 m. Standard lid thickness : 1.0 mm
 Each 2 m length is supplied with 2 saddle clamps and screws
 Duct to floor fixings are not supplied

Pack	Cat. Nos.	In-screed service outlet base boxes
		Service outlet base boxes are supplied empty To complete the system, the outlet base box requires outlet plates, lid and trim Outlet plates, lids and trims ordered separately, (see p. 50) Use a 2 or 4 compartment service outlet box with 2 compartment duct 2 compartment box can only be used with 150 mm wide ducting
		To fit 25 mm deep ducting
1	AFU2BB78	To suit screed 65 mm to 80 mm deep 2 compartment to suit 25 mm shallow ducting
1	AFU3BB78	3 compartment to suit 25 mm shallow ducting
1	AFU4BB78	4 compartment to suit 25 mm shallow ducting
		To fit 38 mm deep ducting
1	AFU2BB90	To suit screed 75 mm to 90 mm deep 2 compartment box to suit 38 mm deep ducting
1	AFU3BB90	3 compartment box to suit 38 mm deep ducting
1	AFU4BB90	4 compartment box to suit 38 mm deep ducting

Pack	Cat. Nos.	In-screed service outlet base boxes (continued)
		20 mm conduit fed
1	AFU1CON78	To suit screed 65 mm to 80 mm deep 1 compartment box to suit 20 mm conduit
1	AFU2CON78	2 compartment box to suit 20 mm conduit
1	AFU3CON78	3 compartment box to suit 20 mm conduit
1	AFU4CON78	4 compartment box to suit 20 mm conduit
		25 mm conduit fed
1	AFU1CON90	To suit screed 75 mm to 90 mm deep 1 compartment box to suit 25 mm conduit
1	AFU2CON90	2 compartment box to suit 25 mm conduit
1	AFU3CON90	3 compartment box to suit 25 mm conduit
1	AFU4CON90	4 compartment box to suit 25 mm conduit



All trims for service outlet boxes can be ABS, stainless steel, brass or powder coated any colour **p. 50**



screed floor service outlet boxes

selection chart

No. of compartments		
Floor box base		
System type 	Flush floor trunking	
	Shallow flush floor trunking 150 x 25 mm – 2 compartment	
	Shallow flush floor trunking 150 x 38 mm – 2 compartment	
	Shallow flush floor trunking 150 x 25 mm – 3 compartment	
	Shallow flush floor trunking 150 x 38 mm – 3 compartment	
	Shallow flush floor trunking 225 x 25 mm – 3 compartment	
	Shallow flush floor trunking 225 x 38 mm – 3 compartment	
	Screed floor box to suit shallow 25 mm ducting	
	Screed floor box to suit deep 38 mm ducting	
	Screed floor box to suit 20 mm conduit	
Screed floor box to suit 25 mm conduit		
Outlet plates		
13 A standard 	13 A twin switched socket plate	
	13 A twin unswitched socket plate	
	13 A twin switched clean earth socket plate	
	13 A triple unswitched socket plate	
	13 A triple unswitched clean earth socket plate	
13 A non-standard 	13 A twin NS switched socket plate	
	13 A twin NS switched clean earth socket plate	
RCD 30 mA passive 	2 gang RCD socket plate ¹	
	2 gang RCD socket plate - clean earth ¹	
Data 	37 x 22 mm – 2 cut-out plate	
	37 x 22 mm – 4 cut-out plate	
	37 x 22 mm – 4 cut-out wave plate ¹	
	37 x 22 mm – 6 cut-out plate	
	47.5 x 23.5 mm – 4 cut-out plate	
General 	2 x standard single outlet 60.3 mm	
	Standard 2 gang outlet plate 120.6 mm	
	51 x 51 mm – 1 cut-out plate	
	51 x 51 mm – 2 cut-out plate	
	Blank plate	
	58 x 53.5 mm – 1 cut-out plate to accept Arteor mounting frame ²	
	58 x 53.5 mm – 2 cut-out plate to accept 2 x Arteor mounting frames ²	
Lids and trims		
	ABS with carpet trim – 6 mm recess	
	Combination with edge trim – 6 mm recess	
	Metal, powder coated with carpet trim – 8 mm recess (RAL 7024)	
	Metal, powder coated with edge trim – 8 mm recess (RAL 7024)	
	Stainless steel with carpet trim – 8 mm recess (Satin)	
	Stainless steel with edge trim – 8 mm recess (Satin)	
	Brass with carpet trim – 8 mm recess (Polished)	
	Brass with edge trim – 8 mm recess (Polished)	

1 : Due to overall depth, these items will NOT fit in the flush floor and shallow flush floor ranges (Cat. Nos. FFO and AFS). When using with underfloor duct systems (Cat. No. AFU) the outlet box must be raised by 8 mm from the lowest point to allow for wiring
 2 : For Arteor mounting frames, refer to the latest Wiring Devices catalogue

	1 compartment	2 compartment	3 compartment	4 compartment
	–	–	FFO3BB	FFO4BB
	–	AFS2BB261	–	AFS4BB261
	–	AFS2BB265	–	AFS4BB265
	–	–	AFS3BB361	AFS4BB361
	–	–	AFS3BB365	AFS4BB365
	–	–	AFS3BB391	AFS4BB391
	–	–	AFS3BB395	AFS4BB395
	–	AFU2BB78	AFU3BB78	AFU4BB78
	–	AFU2BB90	AFU3BB90	AFU4BB90
	AFU1CON78	AFU2CON78	AFU3CON78	AFU4CON78
	AFU1CON90	AFU2CON90	AFU3CON90	AFU4CON90
	SP3201	SP3201	SP3201	SP4201
	SP3200	SP3200	SP3200	SP4200
	SP3211	SP3211	SP3211	SP4211
	SP3300	SP3300	SP3300	SP4300
	SP3310	SP3310	SP3310	SP4310
	SP3221	SP3221	SP3221	SP4221
	SP3231	SP3231	SP3231	SP4231
	SP3202	SP3202	SP3202	SP4202
	SP3212	SP3212	SP3212	SP4212
	SP3203	SP3203	SP3203	SP4203
	SP3403	SP3403	SP3403	SP4403
	SP3404	SP3404	SP3404	SP4404
	SP3603	SP3603	SP3603	SP4603
	SP3408	SP3408	SP3408	SP4408
	SP3205	SP3205	SP3205	–
	SP3105	SP3105	SP3105	–
	SP3106	SP3106	SP3106	SP4106
	SP3206	SP3206	SP3206	SP4206
	SP3000	SP3000	SP3000	SP4000
	SP3107	SP3107	SP3107	SP4107
	SP3207	SP3207	SP3207	SP4207
	–	FBL2ABS	FBL3ABS	FBL3ABS
	–	FBL2COM	FBL3COM	FBL3COM
	FBL1MCT	FBL2MCT	FBL3MCT	FBL3MCT
	FBL1MET	FBL2MET	FBL3MET	FBL3MET
	FBL1SCT	FBL2SCT	FBL3SCT	FBL3SCT
	FBL1SET	FBL2SET	FBL3SET	FBL3SET
	FBL1BCT	FBL2BCT	FBL3BCT	FBL3BCT
	FBL1BET	FBL2BET	FBL3BET	FBL3BET

outlet plates for floor trunking

power and data

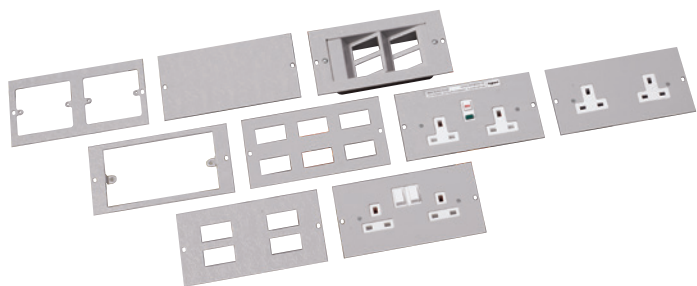

Screed floor outlet boxes selection chart **p. 48-49**
Installation details **p. 29**

Plates to fit 1, 2 and 3 compartment boxes are all 100 mm wide
Plates to fit 4 compartment boxes are 75 mm wide
Non-standard sockets have a round earth pin
Due to overall depth, RCD sockets and wave type data plates will NOT fit in the flush floor and shallow flush floor ranges (Cat. Nos. FFO/AFS).
When using with underfloor duct systems (Cat. No. AFU) the outlet box must be raised by 8 mm from the lowest point to allow for wiring

Pack	Cat. Nos.		Power and data plates
	1, 2, 3 comp. 100 mm wide	4 comp. 75 mm wide	
			13 A standard socket plates
1	SP3201	SP4201	Twin switched
1	SP3200	SP4200	Twin unswitched
1	SP3211	SP4211	Twin switched – clean earth
1	SP3300	SP4300	Triple unswitched
1	SP3310	SP4310	Triple unswitched – clean earth
			13 A non-standard socket plates
1	SP3221	SP4221	Twin NS switched
1	SP3231	SP4231	Twin NS switched – clean earth
			RCD socket plates
			Double pole 30 mA passive will not trip in event of power failure. Eliminating need to manually reset all units after power failure
1	SP3202	SP4202	2 gang
1	SP3212	SP4212	2 gang – clean earth
			Data plates
1	SP3203	SP4203	37 x 22 mm – 2 cut-outs
1	SP3403	SP4403	37 x 22 mm – 4 cut-outs
1	SP3404	SP4404	37 x 22 mm – 4 cut-outs (wave plate)
1	SP3603	SP4603	37 x 22 mm – 6 cut-outs
1	SP3408	SP4408	47.5 x 23.5 mm – 4 cut-outs
			General
1	SP3205	-	2 x standard single outlet 60.3 mm
1	SP3105	-	Standard 2 gang outlet plate 120.6 mm
1	SP3106	SP4106	51 x 51 mm – 1 cut-out plate
1	SP3206	SP4206	51 x 51 mm – 2 cut-out plate
1	SP3000	SP4000	Blank plate
1	SP3107	SP4107	58 x 53.5 mm – 1 cut-out plate to accept Arteor mounting frame (Cat. No. 576016) ¹
1	SP3207	SP4207	58 x 53.5 mm – 2 cut-outs plate to accept 2 x Arteor mounting frames (Cat. No. 576016) ¹
			Fasteners
50	SPSCREW		M3.5 x 6 spare socket plate screws

¹ : For Arteor mounting frames, refer to the latest Wiring Devices catalogue

lids and trims for floor trunking



Screed floor outlet boxes selection chart **p. 48-49**
Installation details **p. 29**

Moulded lids and trims are manufactured from durable ABS and feature a quick fit / release ratchet system
ABS lid and trim versions are supplied with 6 mm carpet recess
Metal lid and trim versions are supplied with 8 mm recess
Metal trim versions are powder coated grey RAL7024 matt as standard
Stainless steel is satin finish as standard
Brass is polished finish as standard

Pack	Cat. Nos.		Floor box lids and trims
	1 comp.	2 comp.	
			1 and 2 compartment
			Carpet trim
1	-	FBL2ABS	ABS
1	FBL1MCT	FBL2MCT	Metal – grey (RAL 7024)
1	FBL1SCT	FBL2SCT	Stainless steel (Satin)
1	FBL1BCT	FBL2BCT	Brass (Polished)
			Edge trim
1	-	FBL2COM	ABS lid/metal trim (ABS/grey)
1	FBL1MET	FBL2MET	Metal – grey (RAL 7024)
1	FBL1SET	FBL2SET	Stainless steel (Satin)
1	FBL1BET	FBL2BET	Brass (Polished)
			3 and 4 compartment
			Carpet trim
1	-	FBL3ABS	ABS
1	-	FBL3MCT	Metal – grey (RAL 7024)
1	-	FBL3SCT	Stainless steel (Satin)
1	-	FBL3BCT	Brass (Polished)
			Edge trim
1	-	FBL3COM	ABS lid/metal trim (ABS/grey)
1	-	FBL3MET	Metal – grey (RAL 7024)
1	-	FBL3SET	Stainless steel (Satin)
1	-	FBL3BET	Brass (Polished)

Metal lids and trims can be powder coated to any RAL reference. Other options, such as lockable lids, are available to special order

Contact us on +44 (0) 370 608 9020

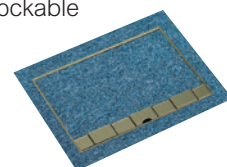

commercial floor trunking systems

flush lid floor trunking

commercial floor trunking systems

recessed lid floor trunking



Dimensions and technical information p. 54
Installation details p. 55

Body and lid manufactured from pre-galvanised sheet steel to BS EN 10346
Standard length : 2.0 m body / 500 mm lid
Standard lid thickness : 2.5 mm
Supplied complete with all necessary connectors and screws
Internal dividers are fitted on all trunking lengths 225 mm and above to provide lid support

Service outlet boxes are not available for this range

Dimensions and technical information p. 54
Installation details p. 55

Body and lid manufactured from pre-galvanised sheet steel to BS EN 10346
Standard length : 2.0 m body / 500 mm lid
Standard lid thickness : 2.5 mm
Lid recess : 3.5 mm
Supplied complete with all necessary connectors and screws
Internal dividers are fitted on all trunking lengths 225 mm and above to provide lid support

Service outlet boxes are not available for this range

Pack	Cat. Nos.	Flush lid floor trunking	
		Trunking length – 2 m	
1	FF42	100 x 50 mm	
1	FF63	150 x 75 mm	
1	FF124	300 x 100 mm	
		90° riser bend	
		Supplied with screeding cover Provides conduit entry with 20 mm knockouts	
1	FFRB42	100 x 50 mm	
1	FFRB63	150 x 75 mm	
1	FFRB124	300 x 100 mm	
		End stop	
1	FFEB42	100 x 50 mm	
1	FFEB63	150 x 75 mm	
1	FFEB124	300 x 100 mm	
		Junction box	
		Supplied with connectors and blanking plates To be configured as a fourway, tee, bend or straight through connector box	
1	FFI42	100 x 50 mm	
1	FFI63	150 x 75 mm	
1	FFI124	300 x 100 mm	

Pack	Cat. Nos.	Recessed lid floor trunking	
		Trunking length – 2 m	
1	FRL42	100 x 50 mm	
1	FRL63	150 x 75 mm	
1	FRL124	300 x 100 mm	
		90° riser bend	
		Supplied with screeding cover Provides conduit entry with 20 mm knockouts	
1	FRLRB42	100 x 50 mm	
1	FRLRB63	150 x 75 mm	
1	FRLRB124	300 x 100 mm	
		End stop	
1	FRLEB42	100 x 50 mm	
1	FRLEB63	150 x 75 mm	
1	FRLEB124	300 x 100 mm	
		Junction box	
		Supplied with connectors and blanking plates To be configured as a fourway, tee, bend or straight through connector box	
1	FRLI42	100 x 50 mm	
1	FRLI63	150 x 75 mm	
1	FRLI124	300 x 100 mm	

Flush lid and recessed lid floor trunking can be supplied in other widths, depths and compartment configurations to special order
Contact us on +44 (0) 370 608 9020

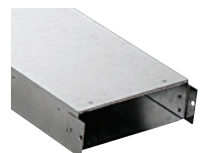

industrial floor trunking systems

chequer plate floor trunking

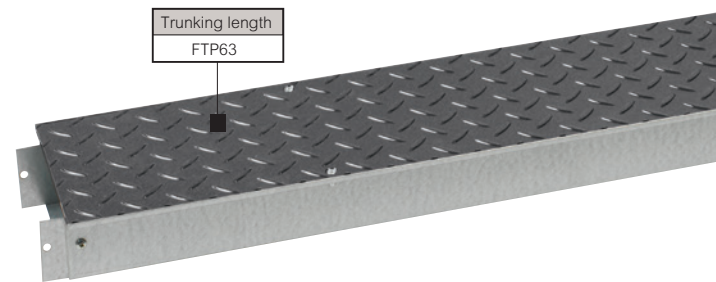

Dimensions and technical information **opposite**
Installation details **p. 55**

Body manufactured from pre-galvanised sheet steel to BS EN 10346
Lid manufactured from mild steel, powder coated grey 18B25
Other colours available to special order
Standard lengths : body 2.0 m, lid 1.0 m
Standard lid thickness : 6.5 mm
Chequer plate floor trunking is available in single compartment as standard complete with lid, all necessary connectors and screws
Internal dividers are fitted on all trunking lengths 225 mm and above to provide lid support
Service outlet boxes are not available for this range

Pack	Cat. Nos.	Chequer plate floor trunking	
		Trunking length – 2 m	
1	FTP42	100 x 50 mm	
1	FTP63	150 x 75 mm	
1	FTP124	300 x 100 mm	
		90° riser bend	
		Supplied with screeding cover Provides conduit entry with 20 mm knockouts	
1	FTPRB42	100 x 50 mm	
1	FTPRB63	150 x 75 mm	
1	FTPRB124	300 x 100 mm	
		End stop	
1	FTPEB42	100 x 50 mm	
1	FTPEB63	150 x 75 mm	
1	FTPEB124	300 x 100 mm	
		Junction box	
		Supplied with connectors and blanking plates To be configured as a fourway, tee, bend or straight through connector box	
1	FTPI42	100 x 50 mm	
1	FTPI63	150 x 75 mm	
1	FTPI124	300 x 100 mm	

Chequer plate floor trunking can be supplied in other widths, depths and compartment configurations to special order
Contact us on +44 (0) 370 608 9020

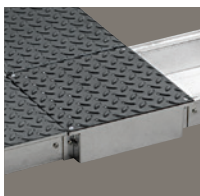

industrial floor trunking systems

dimensions and technical information

Chequer plate floor trunking

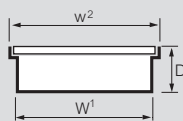

W¹ = Overall trunking width
D = Overall trunking depth
w² = Overall width including trunking lid

Cat. No.	W ¹	D	w ²
FTP42	100	50	150
FTP63	150	75	200
FTP124	300	100	350

90° riser bends

Duct depth	A
50	50
75	75
100	100

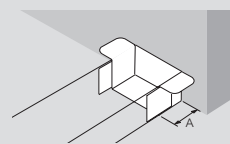

Junction box

Trunking width	A
100	150
150	200
300	350

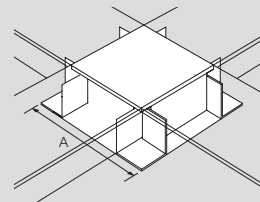

commercial floor trunking systems

dimensions and technical information

Flush floor trunking

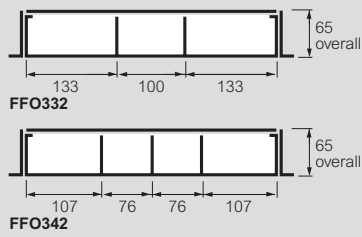

90° riser bends

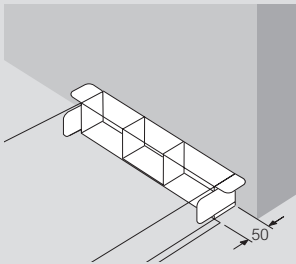

Back entry skirting adaptor

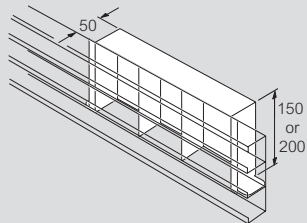

Cable trunking adaptors

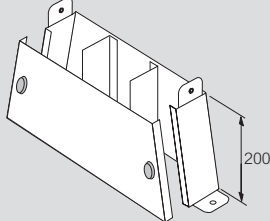

Junction box

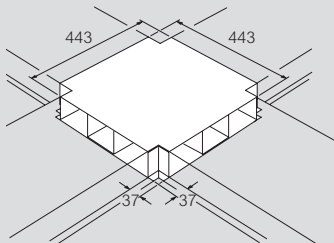

Service outlet boxes

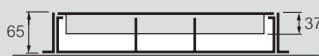

Reduced cabling area when fitting service outlet box

All dimensions (mm) are nominal

Shallow flush floor trunking

Cat. No.	W	D
AFS261	155	25
AFS265	155	38
AFS361	155	25
AFS365	155	38
AFS391	230	25
AFS395	230	38

W = Overall trunking width
D = Overall trunking depth

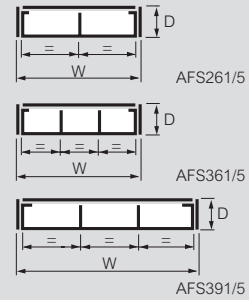

90° riser bends

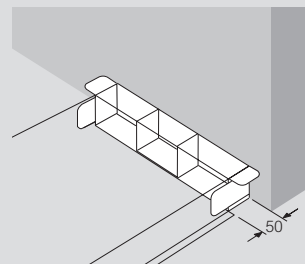

Back entry skirting adaptor

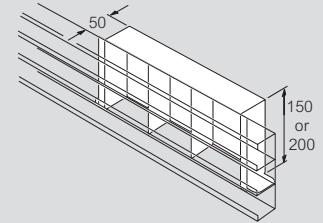

Cable trunking adaptors

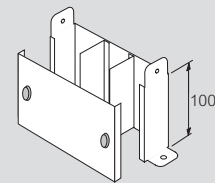

Junction box

Trunking width	A
150	223
225	298

A = Trunking end to end

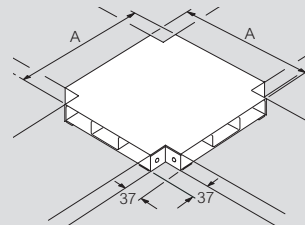

Service outlet boxes

Compartment	W	L	H
2C	297	274	65
3C	372	274	65
4C	372	274	65

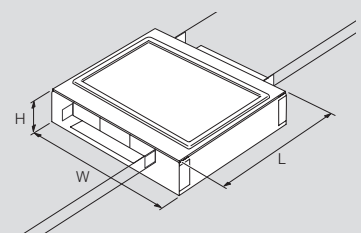

commercial floor trunking systems

dimensions and technical information (continued)

Underfloor duct

Cat. No.	W	D
AFU261	150	25
AFU265	150	38

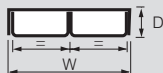

Cat. No.	W	D
AFU361	150	25
AFU365	150	38
AFU391	225	25
AFU395	225	38
AFU311	300	25
AFU315	300	38

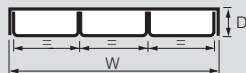

W = Overall ducting width
D = Overall ducting depth

90° riser bends

Duct depth	A
25	65
38	75

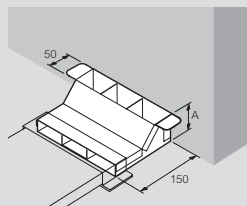

90° flat bends

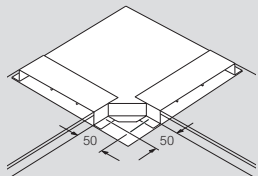

Junction box

Shallow junction box to suit 25 mm duct / 20 mm conduit			
Junction box trunking width	A	B	
150	300	336	
225	300	336	
300	375	411	

Deep junction Box to suit 38 mm duct / 25 mm conduit			
Junction box trunking width	A	B	
150	300	336	
225	300	362	
300	375	411	

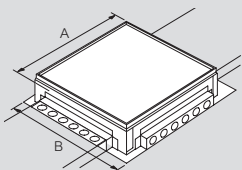

Service outlet box

Compartment	W	L
1C	175	245
2C	275	245
3C	350	245
4C	350	245

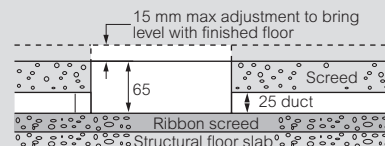
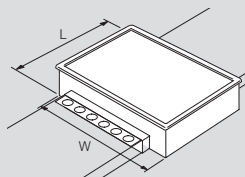

65-80 mm
AFU2CON78
AFU3CON78
AFU4CON78
AFU2BB78
AFU3BB78
AFU4BB78

Using a 25 mm deep duct, junction boxes and service outlet boxes provide conduit entry with 20 mm knockouts only, and are adjustable from 65 to 80 mm deep

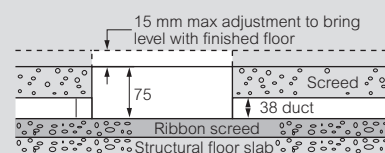

75-90 mm
AFU2CON90
AFU3CON90
AFU4CON90
AFU2BB90
AFU3BB90
AFU4BB90

Using a 38 mm deep duct, junction boxes and service outlet boxes provide conduit entry with 20/25 mm combination knockouts and are adjustable from 75 to 90 mm deep

Loading data

Load tests carried out to two standards BS EN (IEC) 61534 and BS EN (IEC) 50085

All tests performed in accordance to the above standards with boxes fitted with plastic lid and carpet trim assembly

Floor box – 1 & 2 compartment :

Small area (point load¹) – 1.5 kN
Large area (plate²) – 3.0 kN

Large Floor Box – 3 & 4 compartment :

Small area (point load¹) – 1.0 kN
Large area (plate²) – 3.0 kN

1 : Point load test = 13.3 mm diameter
2 : Plate load test = 130.0 mm diameter

Flush lid and recessed lid floor trunking

Flush lid

Cat. No.	W	D	d
FF42	102.5	50	47.5
FF63	152.5	75	72.5
FF124	302.5	100	97.5

W = Overall trunking width
d = Depth to underside of trunking lid
D = Overall trunking depth

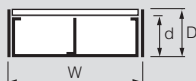

Recessed lid

Cat. No.	W	D	d
FRL42	102.5	50	44
FRL63	152.5	75	69
FRL124	302.5	100	94

W = Overall trunking width
d = Depth to underside of trunking lid
D = Overall trunking depth



90° riser bends

For flush lid and recessed lid floor trunking

Duct depth	A
50	50
75	75
100	100

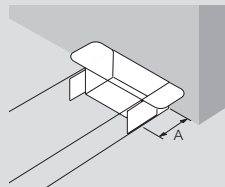

Junction box

For flush lid and recessed lid floor trunking

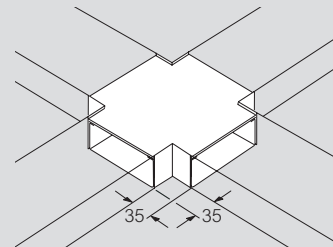

All dimensions (mm) are nominal

commercial floor trunking systems

dimensions and technical information (continued)

■ Installation details

Flush floor trunking in screeded floor

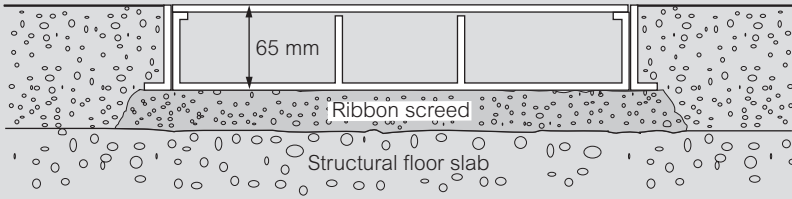

Shallow flush floor trunking in screeded floor

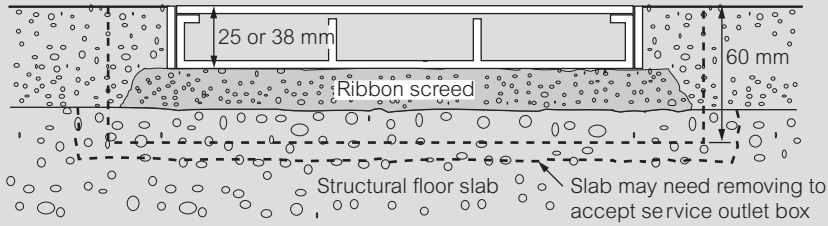

Underfloor duct in screeded floor

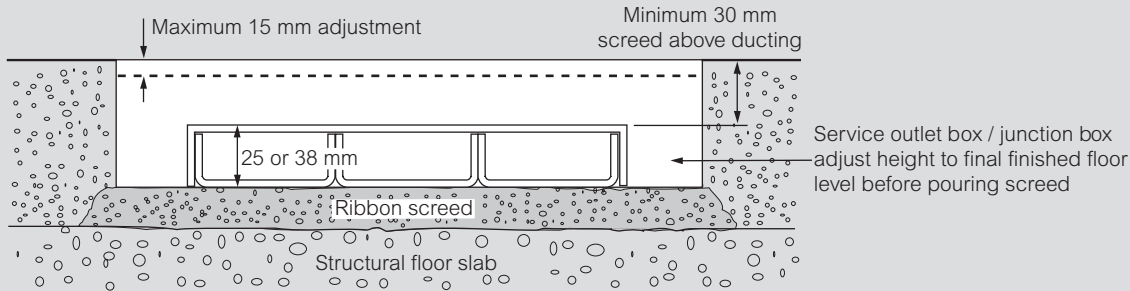

Flush lid floor trunking in screeded floor

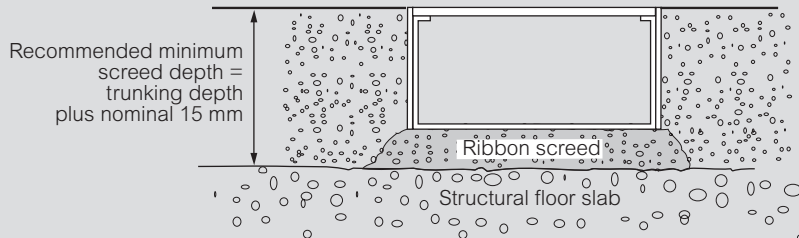

Recessed lid floor trunking in screeded floor

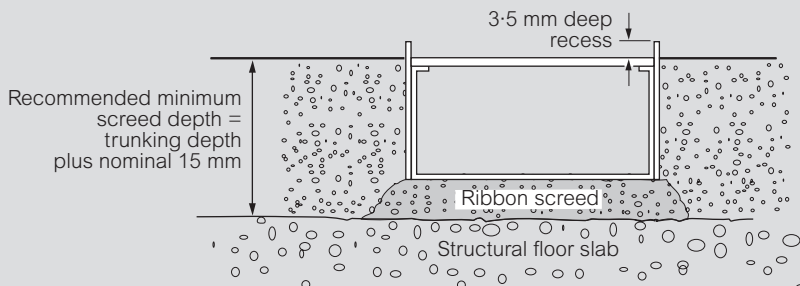

Chequer plate floor trunking in screeded floor

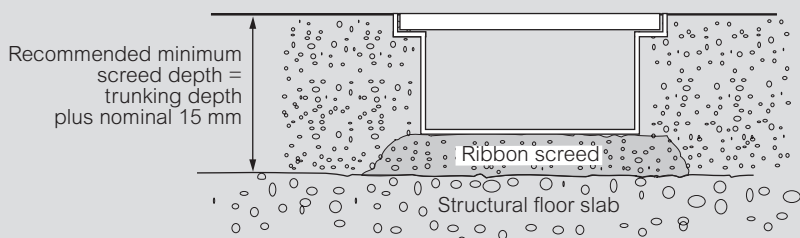

Cat. Nos.	Page No.	Cat. Nos.	Page No.	Cat. Nos.	Page No.	Cat. Nos.	Page No.	Cat. Nos.	Page No.	Cat. Nos.	Page No.
0800 00		8403700	36	AFU2618	46	FBL2BET	27	MP351045	9	MP351536	11
0880 61	31	8403722	-	AFU2652	-	FBL2COM	-	MP351046	11	MP351563	6
0880 62	-	8403730	-	AFU2653	-	FBL2MCT	-	MP351073	7	MP351565	8
0880 64	-	8403740	-	AFU2654	-	FBL2MET	-	MP351075	9	MP351566	10
0880 69	-	8403750	37	AFU2655	-	FBL2SET	-	MP351076	11	MP351567	13
0893 07	30	8403751	-	AFU2656	-	FBL2SCT	-	MP351077	13	MP351597	-
5000 00		8406000	36	AFU3BB78	47	FBL3ABS	-	MP351103	7	MP820329	15
5720 21	15	8406022	-	AFU3BB90	-	FBL3COM	-	MP351105	9	MP820339	-
5720 78	-	8406030	-	AFU3CON78	-	FBL3BCT	-	MP351106	11	P	
5720 96	-	8406040	-	AFU3CON90	-	FBL3MCT	-	MP351107	13	PED1WHI	14
5721 17	-	8406072	37	AFU311	46	FBL3SCT	-	MP351173	6	PED2WHI	-
5721 30	-	8406073	-	AFU315	-	FBL3BET	-	MP351175	8	PED3WHI	-
5723 03	-	8409000	36	AFU361	-	FBL3MET	-	MP351176	10	PED4WHI	-
5723 04	-	8409022	-	AFU365	-	FBL3SET	-	MP351177	12	PED8WHI	-
5723 22	-	8409030	-	AFU391	-	FF42	51	MP351189	7	PG6	30
5723 23	-	8409040	-	AFU395	-	FF63	-	MP351203	6	PG6D	-
5724 67	-	8409081	37	AFU3112	-	FF124	-	MP351205	8	PG6PD	-
5725 21	-	8412000	36	AFU3113	-	FFEB42	-	MP351206	10	PG6RCD	-
5725 78	-	8412022	-	AFU3115	-	FFEB63	-	MP351207	12	S	
5725 96	-	8412030	-	AFU3117	-	FFEB124	-	MP351220	6	SG6	30
5726 17	-	8412040	-	AFU3118	-	FFI42	-	MP351230	-	SLAB1	26
5726 30	-	A		AFU3152	-	FFI63	-	MP351233	-	SLAB2	-
5728 03	-	AFS2BB261	45	AFU3153	-	FFI124	-	MP351235	8	SLAB3	-
5728 04	-	AFS2BB265	-	AFU3154	-	FFO3BB	44	MP351236	10	SLAB4	-
5728 22	-	AFS2BB361	-	AFU3155	-	FFO4BB	-	MP351237	12	SPSCREW	27
5728 23	-	AFS3BB361	-	AFU3156	-	FFO330	-	MP351240	6	SP3000	-
6000 00		AFS3BB365	-	AFU3613	-	FFO332	-	MP351250	7	SP3105	-
6781 34	15	AFS3BB391	-	AFU3617	-	FFO342	-	MP351260	6	SP3106	-
6781 38	-	AFS3BB395	-	AFU3618	-	FFO3311	-	MP351273	-	SP3107	-
7000 00		AFS4BB261	-	AFU3653	-	FFO3312	-	MP351275	8	SP3200	-
7300 34	15	AFS4BB265	-	AFU3654	-	FFO3313	-	MP351276	10	SP3201	-
7300 36	-	AFS4BB361	-	AFU3656	-	FFO3411	-	MP351277	12	SP3202	-
7300 60	-	AFS4BB365	-	AFU3912	-	FFO3413	-	MP351279	9	SP3203	-
7300 65	-	AFS4BB391	-	AFU3913	-	FFOS3SK6	-	MP351289	11	SP3205	-
7300 70	-	AFS4BB395	-	AFU3915	-	FFOS3SK8	-	MP351299	9	SP3206	-
7300 75	-	AFS261	-	AFU3917	-	FFOS4SK6	-	MP351303	6	SP3207	-
7300 91	-	AFS2613	-	AFU3918	-	FFOS4SK8	-	MP351305	8	SP3211	-
7330 92	-	AFS2614	-	AFU3952	-	FFOT332T	-	MP351306	10	SP3212	-
7330 93	-	AFS2615	-	AFU3953	-	FFOT342T	-	MP351307	12	SP3221	-
7330 94	-	AFS265	-	AFU3954	-	FFRB42	51	MP351309	11	SP3222	-
8000 00		AFS2653	-	AFU3955	-	FFRB63	-	MP351319	7	SP3231	-
8218 21	37	AFS2654	-	AFU3956	-	FFRB124	-	MP351333	6	SP3232	-
8218 22	-	AFS2655	-	AFU4BB78	47	FRL42	-	MP351335	8	SP3233	-
8218 23	-	AFS361	-	AFU4BB90	-	FRL63	-	MP351336	10	SP3300	-
8218 24	-	AFS391	-	AFU4CON78	-	FRL124	-	MP351337	12	SP3403	-
8218 25	-	AFS395	-	AFU4CON90	-	FRLEB42	-	MP351367	-	SP3404	-
8218 26	-	AFS3611	-	AFUSFSKS	46	FRLEB63	-	MP351389	7	SP3408	-
8218 27	-	AFS3613	-	AFUTFT	-	FRLEB124	-	MP351393	6	SP3603	-
8330 34	15	AFS3614	-	AM1B	30	FRLI42	-	MP351395	8	SP4000	-
8330 37	-	AFS365	-	AM1C	-	FRLI63	-	MP351396	10	SP4106	-
8330 60	-	AFS3653	-	C		FRLI124	-	MP351397	12	SP4107	-
8330 65	-	AFS3654	-	CAV185	26	FRLRB42	-	MP351399	11	SP4200	-
8330 70	-	AFS3911	-	CAV275	-	FRLRB63	-	MP351409	7	SP4201	-
8330 75	-	AFS3913	-	CAV285	-	FRLRB124	-	MP351439	-	SP4202	-
8330 86	-	AFS3914	-	CAV285	-	FTP42	52	MP351449	-	SP4203	-
8330 91	-	AFS3915	-	CAV375	-	FTP63	-	MP351453	-	SP4206	-
8330 92	-	AFS3953	-	CAV385	-	FTP124	-	MP351455	9	SP4207	-
8330 93	-	AFS3954	-	CAV475	-	FTPI42	-	MP351456	11	SP4211	-
8330 94	-	AFS3955	-	CAV485	-	FTPI63	-	MP351459	7	SP4212	-
8330 98	-	AFSSFSKS	-	CAV2110	-	FTPI124	-	MP351469	-	SP4221	-
80000 00		AFSTFT	-	CAV3110	-	FTPEB42	-	MP351483	-	SP4231	-
8190232	37	AFU1CON78	47	CAV4110	-	FTPEB63	-	MP351485	9	SP4300	-
8400010	36	AFU1CON90	-	CB3	-	FTPEB124	-	MP351486	11	SP4310	-
8400020	-	AFU2BB78	-	F		FTPRB42	-	MP351499	7	SP4403	-
8400030	37	AFU2BB90	-	FBL1BCT	27	FTPRB63	-	MP351513	-	SP4404	-
8400060	36	AFU2CON78	-	FBL1MCT	-	FTPRB124	-	MP351515	9	SP4408	-
8400061	-	AFU2CON90	-	FBL1SCT	-	L		MP351516	11	SP4603	-
		AFU261	46	FBL1SET	-	LSG2	30	MP351523	6		
		AFU265	-	FBL1BET	-	M		MP351525	8		
		AFU2612	-	FBL1MET	-	MP351029	7	MP351526	10		
		AFU2613	-	FBL1SET	-	MP351043	-	MP351527	12		
		AFU2615	-	FBL2ABS	-			MP351533	7		
		AFU2617	-	FBL2BCT	-			MP351535	9		

Protection classifications

Protection against solid bodies and liquids : Index of protection - IP xx

Degree of protection of enclosures of electrical equipment in accordance with standards IEC 60529, BS EN 60529
Up to 1 000 V~ and 1 500 V=

1st digit: protection against solid bodies		Additional letter IP XX (ABCD): protection against direct contact resulting from the access to hazardous current-carrying parts		2nd digit: protection against liquids			
IP	tests	IP	tests	protection	IP	tests	protection
0	No protection				0		No protection
1	Protected against solid bodies larger than 50 mm	A	The back of the hand remains remote from dangerous parts		1	Protected against vertically-falling drops of water (condensation)	
2	Protected against solid bodies larger than 12.5 mm	B	The dangerous parts can not be touched when introducing a finger		2	Protected against drops of water falling at up to 15° from the vertical	
3	Protected against solid bodies larger than 2.5 mm	C	The dangerous parts can not be touched when introducing a tool (eg a screwdriver)		3	Protected against drops of rain water at up to 60° from the vertical	
4	Protected against solid bodies larger than 1 mm				4	Protected against projections of water from all directions	
5	Protected against dust (no harmful deposit)				5	Protected against jets of water from all directions	
6	Completely protected against dust	D	The dangerous parts cannot be touched when introducing a wire		6	Protected against jets of water of similar force to heavy seas	
					7	Protected against the effects of immersion	
					8	Protected against prolonged effects of immersion under pressure	
					9	Protected against high pressure and temperature water jets	
					9K1		

Legrand appliances for domestic applications, once installed, have a degree of protection IP equal to or greater than IP 2XC
1 : In accordance to ISO 20653

Protection against mechanical impact : Index of protection - IK

According to standards IEC 62262 and BS EN 62262

IK	Tests	Impact energy (in Joules)
IK 00		0
IK 01	0.2 kg, 75 mm	0.15
IK 02	0.2 kg, 100 mm	0.2
IK 03	0.2 kg, 175 mm	0.35
IK 04	0.2 kg, 250 mm	0.5
IK 05	0.2 kg, 350 mm	0.7
IK 06	0.5 kg, 200 mm	1
IK 07	0.5 kg, 400 mm	2
IK 08	1.7 kg, 295 mm	5
IK 09	5 kg, 200 mm	10
IK 10	5 kg, 400 mm	20

A product previously classed as IP xx-7 can be assumed to fulfill the conditions of an IP xx - IK 08

This table can be used to ascertain the resistance of a product to an impact given in Joules from the IK code (graduated from 00 to 10). It can also be used to ascertain the correspondence with the old IP code 3rd digit and the corresponding external "Ag" conditions.

The contents of the Protection Classifications charts are for guidance only. If you have any doubt as to the interpretation of the information contained therein, please refer either to the standard itself or contact Legrand.

Health and Safety at Work, etc. Act. 1974

Statement to Purchasers and Prospective Purchasers

1. Section 6 of this Act provides that manufacturers, designers, importers or suppliers of articles for use at work have a duty to ensure so far as is reasonably practical, that the article will be safe and without risk to health when properly used. An article is not regarded as being 'properly used' if it is used without regard to any relevant information or advice relating to its use made available by the manufacturer, designer, importer or supplier.

2. With regard to these provisions the following is given as a guide to the information which is readily available to you. This information relates to those products detailed in our catalogue(s) or associated literature or may be obtained by specific request to the Company.

3. All products should be installed and maintained in accordance with good engineering practice and relevant British or

other applicable standards, regulations for the installation of equipment by the Institute of Electrical Engineers or any other applicable Codes of Practice.

Health and Safety at Work Act

The Electricity at Work Regulations, 1989

1. All installations and maintenance should be carried out within the provision of the above Act and by persons so qualified as defined in the Act.

2. Information and advice on the suitability of our products can be obtained from Legrand Electric Limited on specific request.

For information concerning wiring device standards outside the UK contact :

BSI

Customer Services

09:00 to 17:00 – Monday to Friday

Tel : +44 (0) 20 8996 9001

Fax : +44 (0) 20 8996 7001

Email : cservices@bsi-global.com

CE marking appears on electrical or electronic products from Legrand and enables the circulation of goods outside the UK.

voltimum

Conditions of sale
Please consult our current price list

In accordance with its policy of continuous improvement the Company reserves the right to change specifications and designs without notice. All illustrations, descriptions, dimensions and weights in this catalogue are for guidance and cannot be held binding on the Company.

Contact details

United Kingdom

Great King Street North,
Birmingham, B19 2LF

Customer Services:

Tel: +44 (0) 345 605 4333

E-mail: legrand.sales@legrand.co.uk

Quotations and Technical Support

Tel: +44 (0) 370 608 9020

E-mail: uk-cmsales@legrand.co.uk

Republic of Ireland:

Tel: +353 (0) 1 295 9673

E-mail: legrand.sales@legrand.co.uk

In accordance with its policy of continuous improvement, the Company reserves the right to change specifications and designs without notice. All illustrations, descriptions, dimensions and weights in this catalogue are for guidance and cannot be held binding on the Company. All contents and design presentation included in this publication are © Legrand Electric Limited. All rights reserved. 2022



This document is printed on sustainably sourced paper. Please recycle.



FOLLOW
US AT



www.legrand.co.uk
www.legrand.ie



www.youtube.com/legrandtvuk

voltimum

www.voltimum.co.uk
www.voltimum.ie



www.twitter.com/legranduk



[www.linkedin.com/
company/legranduk](https://www.linkedin.com/company/legranduk)



Head office (UK and Ireland):

Legrand Electric Limited
Great King Street North, Birmingham, B19 2LF
Tel: +44 (0) 370 608 9000
Website: www.legrand.co.uk