

# PROTECTION, CONTROL & MEASUREMENT PRODUCT GUIDE

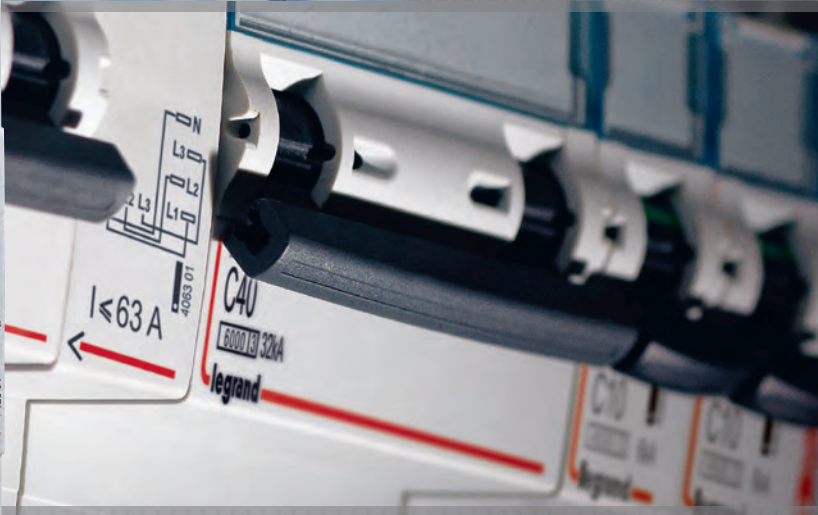

# Global strength built on local knowledge

Legrand is the global specialist in electrical and digital building infrastructures. Innovation is the driving force behind its development.

With an increasing investment in research and development (circa 5% of sales) and more than 4,000 active patents, the Legrand Group is focused on maintaining a high rate of new product launches that present innovative solutions to the market.

## CORPORATE SOCIAL RESPONSIBILITY

Legrand's CSR roadmap is a natural extension to the governance and sustainable development approach in which the company has been engaged for many years. The CSR roadmap firmly asserts Legrand's ongoing commitment to sustainable development.



## LEGRAND'S POWER DISTRIBUTION BUSINESS UNIT

From Zucchini transformers, through high power distribution and rising main busbar to Electrak powertrack, desk modules and lighting control, Legrand's power distribution business unit provides market leading solutions to the increasing demands of today's buildings.





## PRODUCT AND TECHNICAL INFORMATION

MCBs DX <sup>3</sup>	4
ID RCDs DX <sup>3</sup>	9
RCBOs DX <sup>3</sup>	11
EMDX <sup>3</sup> METERING	14
CURRENT TRANSFORMERS (CT)	16
FUSE CARRIERS AND FUSES	20
SWITCH DISCONNECTORS AND CHANGEOVER SWITCHES	28
CONTROL AND COMPACT TRANSFORMERS	34
FILTERED POWER SUPPLIES	40
CX <sup>3</sup> POWER CONTACTORS	42
CX <sup>3</sup> PUSH BUTTONS / CONTROL SWITCHES, LED INDICATORS AND TRANSFORMERS	45
DIGITAL AND ANALOGUE TIME SWITCHES	50
LIGHT SENSITIVE AND TIME-LAG SWITCHES	57

# CONTENTS

# POWER PROTECTION

In developing its range of DX<sup>3</sup> protection devices, Legrand has paid particular attention to the performance of each individual product, with every item being individually tested before it leaves the factory.

You're in safe hands with Legrand's power protection range.

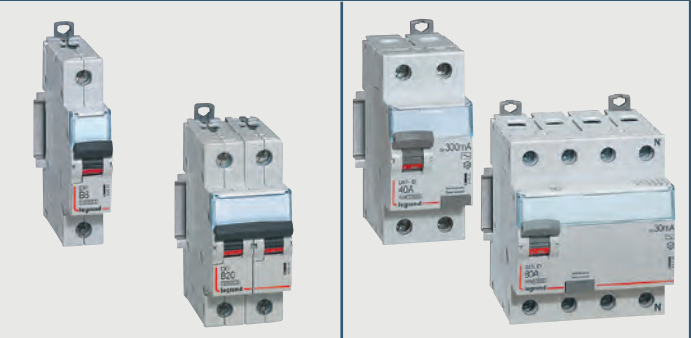

### DX<sup>3</sup> MCBs

**TECH DATA**  
 Breaking capacity: 10kA, 16kA  
 Pole range: single to four pole  
 Current rating: 1A to 125A  
 Tripping characteristics: Type B, C, D  
 see p. 4 to 8

### DX<sup>3</sup> RCDs

**TECH DATA**  
 Pole range: double and four pole  
 Current rating: 16A to 100A  
 Types: A, AC  
 Sensitivity: 10mA, 30mA, 100mA, 300mA and 500mA  
 see p. 9 to 10



THE FIGHT AGAINST COUNTERFEIT...  
 MANY DX<sup>3</sup> PRODUCTS ARE MARKED  
 WITH A UNIQUE REGISTRATION  
 NUMBER. VISIT:  
[WWW.LEGRAND-COPYTRACER.COM](http://WWW.LEGRAND-COPYTRACER.COM)

## The DX<sup>3</sup> range...

Legrand's DX<sup>3</sup> range of MCBs, RCDs, RCBOs and switch disconnectors (p. 4-12) offer a variety of enhanced features...



**WIRE GUIDE FLAP**  
 ensures the wire is in the correct position

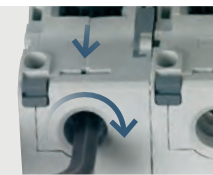

**RISING CLAMP TERMINALS**  
 ensure a high quality, durable connection



**INCREASED SAFETY**  
 guaranteed IP2X protection with no risk of contact with live parts, even with faceplate open

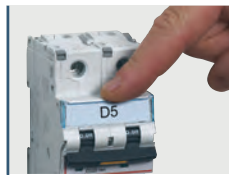

**INNOVATIVE LABEL HOLDER**  
 offers improved opening mechanism and grip on label, plus enhanced dust protection



**CLEAR, CONCISE MARKING**  
 Curve, rating and breaking capacity are easily identified



**THE DOUBLE CLIP**  
 enables a device to be replaced without disconnecting the entire row. Now available on all devices



N

### DX³ RCBOs

#### TECH DATA

Breaking capacity: 10kA  
 Pole range: single pole, single pole + neutral to four pole  
 Current rating: 3A to 63A  
 Tripping characteristics: Type B, C  
 Sensitivity: 10mA, 30mA, and 300mA

see p. 11 to 12



N

### EMDX³ metering devices

A wide range of metering devices available:

- Electricity meters and multi-function measuring units
- Door and DIN rail mounting options
- MID certified meters
- Supported by supervision software and remote web-based monitoring system

see p. 13 to 19



### Fuses and fuse carriers

In addition to DIN rail mounted protection devices, Legrand offers a comprehensive range of cylindrical fuses, blade fuses and modular fuse carriers.

see p. 20 to 25

## ... with added benefits for MCBs

80 to 125A DX³ MCBs benefit from all of the innovations offered by the DX³ range and in addition offer a whole host more...



Temperature rise  
**-20%**

**RELIABLE CONNECTIONS**  
 Compensation for the effect of loosening to ensure excellent hold over time and consistent contact

**LOCK IN OPEN POSITION**  
 simply by using a single Colring cable tie (see p. 6)

**EASY TAP-OFF CONNECTION**  
 IP2X automatic terminals safely connect an auxiliary circuit or measuring device



**ALLEN SCREW**  
 and Allen key make it easier to tighten to required torque

**RETRACTABLE INSULATING SHIELDS**  
 no additional accessories required to isolate connections on high rating devices no matter what the breaking capacity



# MCBs DX<sup>3</sup> 10000 - 16 kA

thermal magnetic circuit breakers from 1 A to 125 A



4088 69



4089 43



4091 11



4092 03

Dimensions **p. 12**  
 Technical information **p. 7-8**

Conform to IEC 60898-1

Breaking capacity

10000 - IEC 60898-1 - 400 V~

16 kA - IEC 60947-2 - 400 V~

Can be equipped with DX<sup>3</sup> auxiliaries and accessories **p. 6**

Pack	Cat. Nos.	MCBs DX <sup>3</sup> 10000 - 16 kA - B curve	
		<b>Single pole 230/400 V~</b>	
		B curve	
		Nominal rating I <sub>n</sub> (A)	Number of modules
1	4088 65	1	1
1	4088 66	2	1
1	4088 67	3	1
1	4088 69	6	1
1	4088 70	10	1
1	4088 72	16	1
1	4088 73	20	1
1	4088 74	25	1
1	4088 75	32	1
1	4088 76	40	1
1	4088 78	63	1
		<b>Double pole 230/400 V~</b>	
1	4089 35	1	2
1	4089 36	2	2
1	4089 37	3	2
1	4089 39	6	2
1	4089 40	10	2
1	4089 42	16	2
1	4089 43	20	2
1	4089 44	25	2
1	4089 45	32	2
1	4089 46	40	2
1	4089 48	63	2
		<b>Triple pole 400 V~</b>	
1	4089 84	1	3
1	4089 85	2	3
1	4089 86	3	3
1	4089 88	6	3
1	4089 89	10	3
1	4089 91	16	3
1	4089 92	20	3
1	4089 93	25	3
1	4089 94	32	3
1	4089 95	40	3
1	4089 96	50	3
1	4089 97	63	3
		<b>Four pole 400 V~</b>	
1	4090 58	1	4
1	4090 62	6	4
1	4090 63	10	4
1	4090 65	16	4
1	4090 66	20	4
1	4090 67	25	4
1	4090 68	32	4
1	4090 69	40	4
1	4090 70	50	4
1	4090 71	63	4

Pack	Cat. Nos.	MCBs DX <sup>3</sup> 10000 - 16 kA - C curve	
		<b>Single pole 230/400 V~</b>	
		C curve	
		Nominal rating I <sub>n</sub> (A)	Number of modules
1	4091 07	1	1
1	4091 08	2	1
1	4091 09	3	1
1	4091 11	6	1
1	4091 12	10	1
1	4091 14	16	1
1	4091 15	20	1
1	4091 16	25	1
1	4091 17	32	1
1	4091 18	40	1
1	4091 19	50	1
1	4091 20	63	1
1	4091 40	80	1
		<b>Double pole 230/400 V~</b>	
1	4091 95	1	2
1	4091 96	2	2
1	4091 97	3	2
1	4091 99	6	2
1	4092 00	10	2
1	4092 02	16	2
1	4092 03	20	2
1	4092 04	25	2
1	4092 05	32	2
1	4092 06	40	2
1	4092 07	50	2
1	4092 08	63	2
1	4092 28	80	3
1	4092 29	100	3
1	4092 30	125	3
		<b>Triple pole 400 V~</b>	
1	4092 47	1	3
1	4092 48	2	3
1	4092 49	3	3
1	4092 51	6	3
1	4092 52	10	3
1	4092 54	16	3
1	4092 55	20	3
1	4092 56	25	3
1	4092 57	32	3
1	4092 58	40	3
1	4092 59	50	3
1	4092 60	63	3
1	4092 80	80	4-5
1	4092 81	100	4-5
1	4092 82	125	4-5
		<b>Four pole 400 V~</b>	
1	4093 29	1	4
1	4093 30	2	4
1	4093 31	3	4
1	4093 33	6	4
1	4093 34	10	4
1	4093 36	16	4
1	4093 37	20	4
1	4093 38	25	4
1	4093 39	32	4
1	4093 40	40	4
1	4093 41	50	4
1	4093 42	63	4
1	4093 62	80	6
1	4093 63	100	6
1	4093 64	125	6

## MCBs DX<sup>3</sup> 10000 - 16 kA

thermal magnetic circuit breakers from 2 A to 125 A



4095 08

Dimensions **p. 12**  
 Technical information **p. 7-8**

Conform to IEC 60898-1

Breaking capacity

10000 - IEC 60898-1 - 400 V~

16 kA - IEC 60947-2 - 400 V~

Can be equipped with DX<sup>3</sup> auxiliaries and accessories **p. 6**

Pack	Cat. Nos.	MCBs DX <sup>3</sup> 10000 - 16 kA - D curve	
		<b>Single pole 230/400 V~</b>	
		D curve	Number of modules
1	4094 25	Nominal rating I <sub>n</sub> (A) 2	1
1	4094 28	6	1
1	4094 30	10	1
1	4094 32	16	1
1	4094 33	20	1
1	4094 34	25	1
1	4094 35	32	1
1	4094 36	40	1
1	4094 37	50	1
1	4094 38	63	1
		<b>Double pole 230/400 V~</b>	
1	4094 44	2	2
1	4094 47	6	2
1	4094 49	10	2
1	4094 51	16	2
1	4094 52	20	2
1	4094 53	25	2
1	4094 54	32	2
1	4094 55	40	2
1	4094 56	50	2
1	4094 57	63	2
1	4094 58	80	3
1	4094 59	100	3
1	4094 60	125	3
		<b>Triple pole 400 V~</b>	
1	4094 92	2	3
1	4094 95	6	3
1	4094 97	10	3
1	4094 99	16	3
1	4095 00	20	3
1	4095 01	25	3
1	4095 02	32	3
1	4095 03	40	3
1	4095 04	50	3
1	4095 05	63	3
1	4095 06	80	4.5
1	4095 07	100	4.5
1	4095 08	125	4.5
		<b>Four pole 400 V~</b>	
1	4095 26	2	4
1	4095 29	6	4
1	4095 31	10	4
1	4095 33	16	4
1	4095 34	20	4
1	4095 35	25	4
1	4095 36	32	4
1	4095 37	40	4
1	4095 38	50	4
1	4095 39	63	4
1	4095 40	80	6
1	4095 41	100	6
1	4095 42	125	6

## MCBs DX<sup>3</sup> 6000 - 10 kA

thermal magnetic circuit breakers from 1 A to 4 A



4079 65



4080 25

Dimensions **p. 12**  
 Technical information **p. 8**

Conform to IEC 60898-1

Breaking capacity

6000 - IEC 60898-1 - 400 V~

10 kA - IEC 60947-2 - 400 V~

Can be equipped with DX<sup>3</sup> auxiliaries and accessories **p. 6**

Pack	Cat. Nos.	MCBs DX <sup>3</sup> 6000 - 10 kA - D curve	
		<b>Single pole 230/400 V~</b>	
		D curve	Number of modules
1	4079 63	Nominal rating I <sub>n</sub> (A) 1	1
1	4079 65	3	1
1	4079 66	4	1
		<b>Double pole 230/400 V~</b>	
1	4080 23	1	2
1	4080 25	3	2
1	4080 26	4	2
		<b>Triple pole 400 V~</b>	
1	4080 81	1	3
1	4080 83	3	3
1	4080 84	4	3

Auxiliaries and accessories **p. 6**



## auxiliaries for MCBs DX<sup>3</sup> and accessories



4062 58







4062 66



Dimensions **p. 12**

Technical information **p. 7-8**

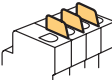
Pack	Cat. Nos.	Auxiliaries for MCBs	Number of modules
		Clip on the left hand side of the MCB (maximum 3) Allow insertion of the supply busbar at the top Auxiliaries common to DX <sup>3</sup> MCBs, RCDs and RCBOs	
		<b>Signalling auxiliaries</b>	
1	4062 58	Auxiliary changeover switch, 6 A - 250 V $\sim$ Indicates the position of the contacts	0.5
1	4062 60	Fault signalling changeover switch, 6 A - 250 V $\sim$ Indicates tripping of the MCB at a fault	0.5
1	4062 62	Auxiliary changeover switch, 6 A - 250 V which can be modified to a fault signalling switch	0.5
1	4062 66	Auxiliary changeover switch, 6 A - 250 V + fault signalling switch, can be modified to 2 auxiliary changeover switches	1

Pack	Cat. Nos.	Accessories	
		<b>Padlocking</b>	
2	4063 03	Support for one $\varnothing$ 5 mm padlock for DX <sup>3</sup> MCBs and RCDs or isolating switches	
3	4063 13	$\varnothing$ 5 mm shackle type padlock	
		<b>Sealable screw cover - 4 separable poles</b>	
2	4063 04	For DX <sup>3</sup> MCBs, 1 module per pole	
		<b>Insulating shields</b>	
1	4063 05	For DX <sup>3</sup> MCBs, 1 module per pole Pole insulating shield (set of 6)	
		<b>Spacing element</b>	
10	4063 07	For heat reduction – 0.5 module	



# technical information

## Breaking capacity in IT neutral earthing system

MCB single pole breaking capacity at 400 V according to IEC 60947-2

	DX <sup>3</sup> <span style="border: 1px solid black; padding: 2px;">10000</span> 16 kA
1P/2P/3P/4P	4 kA

## Breaking capacity in the event of short-circuit to earth and insulation voltage

	1P/2P/3P/4P 230/400 V~ MCBs DX <sup>3</sup> <span style="border: 1px solid black; padding: 2px;">10000</span> 16 kA
Icn 1	16000 A
Ui	500 V

Icn 1 : Breaking capacity on 1 pole for multipole MCBs in the event of short-circuit to earth

Ui : Rated insulation voltage

## Terminal connection cross-sections (mm<sup>2</sup>)

Copper cable	Rigid	Flexible
DX <sup>3</sup> <span style="border: 1px solid black; padding: 2px;">6000</span> 10 kA	35	25
DX <sup>3</sup> <span style="border: 1px solid black; padding: 2px;">10000</span> 16 kA		
Auxiliaries	2.5	2.5

## Technical characteristics of auxiliaries

Max. connection cross-section : 2.5 mm<sup>2</sup>  
Operating temperature : -25°C to +70°C

## Signalling auxiliaries

Umin. : 24 V~/= and Imin. : 5 mA

## MCB tripping curves

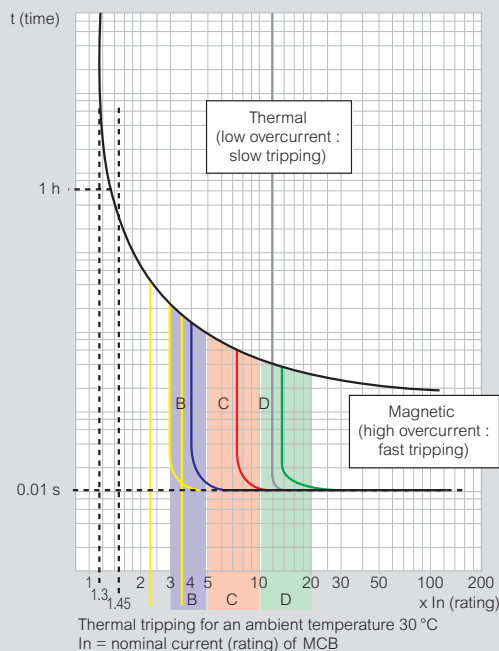

Curves	Magnetic threshold settings
B	3 to 5 In
C	5 to 10 In
D	10 to 14 In (10 to 20 acc. to the stds)

## MCB selectivity table

MCBs/MCBs (in A)

Downstream MCB	Upstream MCB	DX <sup>3</sup> <span style="border: 1px solid black; padding: 2px;">10000</span> - 16 kA B curve				DX <sup>3</sup> <span style="border: 1px solid black; padding: 2px;">10000</span> - 16 kA C curve						
		In (A)	32	40	50	63	32	40	50	63	80	100
DX <sup>3</sup> <span style="border: 1px solid black; padding: 2px;">10000</span> - 16 kA B & C curve	≤ 6	128	160	200	252	240	300	375	472	4000	T	T
	10	128	160	200	252	240	300	375	472	3000	5000	T
	16	128	160	200	252	240	300	375	472	2000	3600	5500
	20		160	200	252	240	300	375	472	1600	3000	4000
	25			200	252	240	300	375	472	1300	2400	3300
	32				252		300	375	472	1000	1800	2700
	40							375	472	800	1600	2400
	50								472	800	900	1700
	63									650	900	1200
	80										600	750
	100											750
125												

T : total selectivity, up to downstream circuit breaker breaking capacity according to IEC 60947-2

The magnetic threshold and the nominal rating of the downstream MCB must always be inferior to the ones of the upstream MCB

## Back up between MCBs (in kA)

In 3 phase networks + N 400/415 V according to IEC 60947-2

MCBs upstream	DX <sup>3</sup> <span style="border: 1px solid black; padding: 2px;">10000</span> 16 kA B, C and D curves	
MCBs downstream	10 to 125 A	
DX <sup>3</sup> <span style="border: 1px solid black; padding: 2px;">6000</span> - 10 kA B, C and D curves	≤ 20 A	16 kA
	25 A	16 kA
	32 A	16 kA
	40 A	16 kA
	50 A	16 kA
	63 A	-

In 3 phase networks + N 230/240 V according to IEC 60947-2

MCBs upstream	DX <sup>3</sup> <span style="border: 1px solid black; padding: 2px;">10000</span> 16 kA B, C and D curves	
MCBs downstream	≤ 32 A   40 to 125 A	
DX <sup>3</sup> <span style="border: 1px solid black; padding: 2px;">6000</span> - 10 kA B, C and D curves	≤ 20 A	32 kA   25 kA
	25 to 40 A	-   25 kA
	50 A	-   25 kA
	63 A	-   25 kA

# protection of DC circuits

## Protection of DC circuits

DX<sup>3</sup> 6000 and DX<sup>3</sup> 10000 MCBs (1P/2P/3P/4P -  $I_n \leq 63$  A) designed for use in 230/400 V $\sim$  supplies, can also be used in DC circuits. In this case, the following deratings and precautions must be taken into account

### 1 - Protection against short-circuits

Max. magnetic tripping threshold : multiplied by 1-4  
 Example : For a C curve MCB for which the AC tripping threshold is between 5 and 10  $I_n$ , the DC tripping threshold will be between 7 and 14  $I_n$

### 2 - Protection against overloads

The time/current thermal tripping curve is the same as for AC

### 3 - Operating voltage

Max. operating voltage : 80 V per pole (60 V for single pole + N MCBs)  
 For voltages higher than this value, several poles must be wired in series

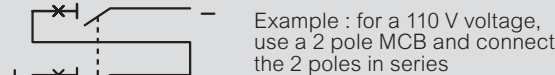

### 4 - Breaking capacity

4000 A for a single pole MCB at max. voltage (80 V= per pole)

For other voltages, the breaking capacities are as follows:

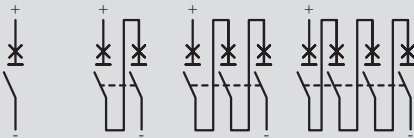

DX <sup>3</sup> 6000		voltage	single pole	2P	3P
Acc. to IEC 60947-2	Icu	≤ 48 V	6 kA	6 kA	
		110 V		6 kA	6 kA
		230 V			
Ics <sup>1</sup>		≤ 48 V	100 %	100 %	
		110 V		100 %	100 %
		230 V			

DX <sup>3</sup> 10000		voltage	single pole	2P	3P	4P
Acc. to IEC 60947-2	Icu	≤ 48 V	10 kA	10 kA		
		110 V		10 kA	10 kA	
		230 V				15 kA
Ics <sup>1</sup>		≤ 48 V	100 %	100 %		
		110 V		100 %	100 %	
		230 V				100 %

1 : As a % of Icu

### 5 - Distribution of breaking poles

To choose the MCB and determine the pole distribution necessary for breaking on each of the polarities, it is necessary to know how the installation is earthed

#### • Supply with one polarity earthed:

Place all the poles necessary for breaking on the other polarity. If isolation is required, an additional pole must be added on the earthed polarity

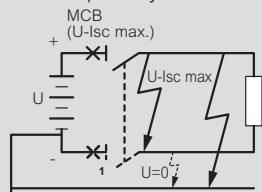

1 : Only if isolation required

#### • Supply with one polarity earthed: (continued)

Example : circuit earthed via the negative polarity /  $U = 110$  V= /  $I_{sc} = 10$  kA /  $I_n = 32$  A

Protect the positive polarity using an MCB capable of breaking 10 kA at 110 V (DX<sup>3</sup> 10000 2P 32 A with 2 poles on the positive polarity)  
 For isolation, use a DX<sup>3</sup> 10000 3P 32 A with 2 poles on the positive polarity and one pole on the negative polarity

DX <sup>3</sup> 10000	voltage	single pole	2P	3P	4P
Acc. to IEC 60947-2	Icu	≤ 48 V	10 kA	10 kA	
		110 V		10 kA	10 kA
		230 V			

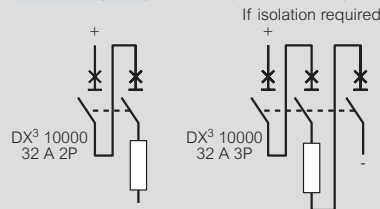

#### • Network earthed via a middle point:

Place on each polarity the number of poles necessary for max.  $I_{sc}$  breaking at half voltage

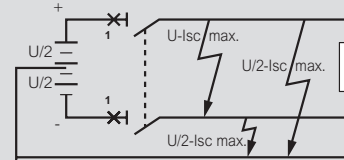

1 : MCB ( $U/2-I_{sc}$  max.)

Example : circuit earthed via a middle point /  $U = 230$  V= /  $I_{sc} = 6$  kA /  $I_n = 10$  A

Protect each polarity using an MCB capable of breaking 6 kA at half voltage, i.e. 115 V (DX<sup>3</sup> 6000 4P 10 A with 2 poles on each polarity)

DX <sup>3</sup> 6000		voltage	single pole	2P	3P
Acc. to IEC 60947-2	Icu	≤ 48 V	6 kA	6 kA	
		110 V		6 kA	6 kA
		230 V			

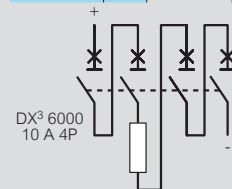

#### • Isolated earth supply:

Distribute the poles necessary for breaking over the 2 polarities to provide protection in the event of a double earth fault (particularly if there are a number of circuits in parallel)

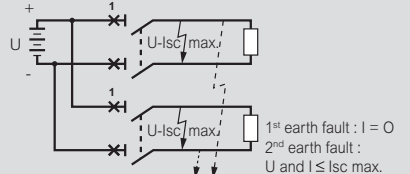

1 : MCB ( $U-I_{sc}$  max.)

Example : isolated earth circuit /  $U = 48$  V= /  $I_{sc} = 4.5$  kA /  $I_n = 40$  A  
 Protect the installation with an MCB capable of breaking 4.5 kA at 48 V and protect each polarity (DX<sup>3</sup> 6000 MCB 2P 40 A with one pole on each polarity)

DX <sup>3</sup> 6000		voltage	single pole	2P	3P
Acc. to IEC 60947-2	Icu	≤ 48 V	6 kA	6 kA	
		110 V		6 kA	6 kA
		230 V			

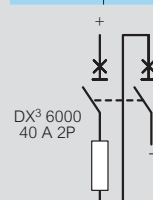

# RCDs - DX<sup>3</sup>-ID

residual current devices 16 A to 100 A - AC and A types



4115 25



4117 05



4117 60



4117 90

Dimensions **p. 12**  
 Technical information **p. 10**

Conform to IEC 61008-1  
 • AC type : detect AC component faults  
 • A type : detect AC and DC component faults  
 Enhanced immunity to unwanted tripping in disturbed environments  
 Can be equipped with DX<sup>3</sup> auxiliaries and accessories **p. 10**

Pack	Cat. Nos.	Double pole - 230 V $\sim$	
1	4115 00	<b>AC Type  10 mA</b> Nominal rating I <sub>n</sub> (A) 16	Number of modules 2
1	4115 04	<b>AC Type  30 mA</b> 25	2
1	4115 05	40	2
1	4115 06	63	2
1	4115 07	80	2
1	4115 08	100	2
1	4115 14	<b>AC Type  100 mA</b> 25	2
1	4115 15	40	2
1	4115 16	63	2
1	4115 17	80	2
1	4115 24	<b>AC Type  300 mA</b> 25	2
1	4115 25	40	2
1	4115 26	63	2
1	4115 27	80	2
1	4115 37	<b>AC Type  100 mA discriminating</b> 100	2
1	4115 43	<b>AC Type  300 mA discriminating</b> 63	2
1	4115 50	<b>A Type  10 mA</b> 16	2
1	4115 54	<b>A Type  30 mA</b> 25	2
1	4115 55	40	2
1	4115 56	63	2
1	4115 57	80	2
1	4115 69	<b>A Type  300 mA</b> 25	2
1	4115 70	40	2
1	4115 71	63	2
1	4115 72	80	2
1	4115 84	<b>A Type  300 mA discriminating</b> 63	2

Pack	Cat. Nos.	Four pole - 400 V $\sim$ - neutral on right-hand side	
1	4117 02	<b>AC Type  30 mA</b> Nominal rating I <sub>n</sub> (A) 25	Number of modules 4
1	4117 03	40	4
1	4117 04	63	4
1	4117 05	80	4
1	4117 12	<b>AC Type  100 mA</b> 25	4
1	4117 13	40	4
1	4117 14	63	4
1	4117 15	80	4
1	4117 22	<b>AC Type  300 mA</b> 25	4
1	4117 23	40	4
1	4117 24	63	4
1	4117 25	80	4
1	4117 32	<b>AC Type  500 mA</b> 25	4
1	4117 33	40	4
1	4117 34	63	4
1	4117 35	80	4
1	4117 45	<b>AC Type  300 mA discriminating</b> 40	4
1	4117 46	63	4
1	4117 59	<b>A Type  30 mA</b> 25	4
1	4117 60	40	4
1	4117 61	63	4
1	4117 62	80	4
1	4117 79	<b>A Type  300 mA</b> 25	4
1	4117 80	40	4
1	4117 81	63	4
1	4117 82	80	4
1	4117 83	100	4
1	4117 90	<b>A Type  500 mA</b> 40	4
1	4117 91	63	4
1	4117 92	80	4
1	4118 00	<b>A Type  300 mA discriminating</b> 40	4
1	4118 01	63	4

Auxiliaries and accessories **p. 10**





4062 58



4062 66

Dimensions **p. 12**  
 Technical information **opposite**

Pack	Cat. Nos.	Auxiliaries for RCDs	Number of modules
		Clip on the left hand side of the RCD (maximum 3) Allow insertion of the supply busbar at the top Auxiliaries common to DX <sup>3</sup> MCBs, RCDs and RCBOs	
		<b>Signalling auxiliaries</b>	
1	4062 58	Auxiliary changeover switch, 6 A - 250 V~ Indicates the position of the contacts	0.5
1	4062 60	Fault signalling changeover switch, 6 A - 250 V~ Indicates tripping of the RCD at a fault	0.5
1	4062 62	Auxiliary changeover switch, 6 A - 250 V which can be modified to a fault signalling switch	0.5
1	4062 66	Auxiliary changeover switch, 6 A - 250 V + fault signalling switch, can be modified to 2 auxiliary changeover switches	1
		<b>Accessories</b>	
		<b>Padlocking</b>	
2	4063 03	Support for one Ø5 mm padlock for DX <sup>3</sup> MCBs and RCDs or isolating switches	
3	4063 13	Ø5 mm shackle type padlock	
		<b>Spacing element</b>	
10	4063 07	For heat reduction – 0.5 module	

### DX<sup>3</sup>-ID - RCDs (residual current devices)

#### Connection cross-section

RCDs	Cable (mm <sup>2</sup> )	
	rigid	flexible
Connection at top and bottom	50	35

### AC type - Standard applications

AC type RCDs detect AC residual currents  
 In the majority of cases (standard applications), they are used for AC current detection at 50/60 Hz

### A type - Specific applications: dedicated lines

In addition to the characteristics of AC type RCDs, A type RCDs also detect DC residual currents  
 They are used whenever fault currents are not sinusoidal  
 They are particularly suitable for the following specific applications (hobs, washing machines...) or materials that may produce DC fault currents, speed drives with frequency inverters, etc.

# RCBOs DX<sup>3</sup> 6000 - 10 kA

residual current circuit breakers from 3 A to 63 A - AC type



4110 02



4111 49



4111 92

Dimensions **p. 12**  
 Technical information **p. 7-8**

Conform to IEC 61009-1

Breaking capacity:

6000 - IEC 61009-1 - 10 kA / IEC 60947-2 for single pole + neutral, double and four pole

• AC type : detect AC component faults

Enhanced immunity to unwanted tripping in disturbed environments

Can be equipped with DX<sup>3</sup> auxiliaries and accessories **p. 12**

Pack	Cat. Nos.	Single pole + neutral - 230 V <sub>~</sub> - C curve	
		Neutral on right-hand side	
		<b>AC Type  10 mA</b>	
		Nominal rating I <sub>n</sub> (A)	Number of modules
1	C curve 4109 93	16	2
		<b>AC Type  30 mA</b>	
1	4109 97	3	2
1	4109 99	6	2
1	4110 00	10	2
1	4110 02	16	2
1	4110 03	20	2
1	4110 04	25	2
1	4110 05	32	2
1	4110 06	40	2
		<b>AC Type  300 mA</b>	
1	4110 21	6	2
1	4110 22	10	2
1	4110 24	16	2
1	4110 25	20	2
1	4110 26	25	2
1	4110 27	32	2
1	4110 28	40	2

Pack	Cat. Nos.	Double pole - 230 V <sub>~</sub>	
		<b>AC Type  10 mA</b>	
		Nominal rating I <sub>n</sub> (A)	Number of modules
1	C curve 4111 49	10	4
1	4111 50	16	4
1	4111 51	20	4
		<b>AC Type  30 mA</b>	
1	4111 57	10	4
1	4111 58	16	4
1	4111 59	20	4
1	4111 60	25	4
1	4111 61	32	4
1	4111 62	40	4
1	4111 63	50	4
1	4111 64	63	4
		<b>Four pole - 400 V<sub>~</sub></b>	
		<b>AC Type  30 mA</b>	
		Nominal rating I <sub>n</sub> (A)	Number of modules
1	C curve 4111 85	10	4
1	4111 86	16	4
1	4111 87	20	4
1	4111 88	25	4
1	4111 89	32	4
1	4111 90	40	7
1	4111 91	50	7
1	4111 92	63	7
		<b>AC Type  300 mA</b>	
1	4112 04	10	4
1	4112 05	16	4
1	4112 06	20	4
1	4112 07	25	4
1	4112 08	32	4
1	4112 09	40	7
1	4112 10	50	7
1	4112 11	63	7

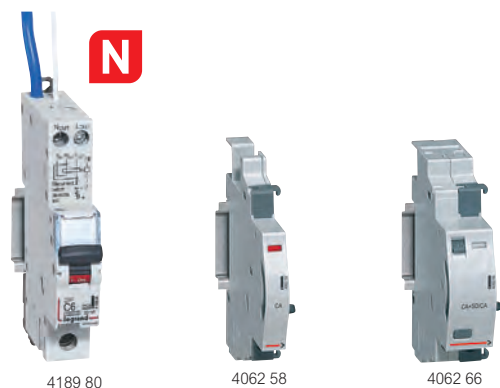

Dimensions **opposite**  
Technical information p. 7-8

Breaking capacity:  
10000 - IEC 61009-1 for single pole  
• AC type : detect AC component faults

Pack	Cat. Nos.	Single pole - 230 V~ - C curve		
		Blue neutral leads		
		<b>AC Type  30 mA</b>		
		Nominal rating In (A)		Number of modules
1	4189 80	6		1
1	4189 81	10		1
1	4189 82	16		1
1	4189 83	20		1
1	4189 84	25		1
1	4189 85	32		1
1	4189 86	40		1
1	4189 87	45		1

		Auxiliaries for RCBOs	
		Clip on the left hand side of the RCBO (maximum 3) Allow insertion of the supply busbar at the top Auxiliaries common to DX <sup>3</sup> MCBs, RCDs and RCBOs	
		<b>Signalling auxiliaries</b>	Number of modules
1	4062 58	Auxiliary changeover switch, 6 A - 250 V~ Indicates the position of the contacts	0.5
1	4062 60	Fault signalling changeover switch, 6 A - 250 V~ Indicates tripping of the RCBO at a fault	0.5
1	4062 62	Auxiliary changeover switch, 6 A - 250 V which can be modified to a fault signalling switch	0.5
1	4062 66	Auxiliary changeover switch, 6 A - 250 V + fault signalling switch, can be modified to 2 auxiliary changeover switches	1

		Accessories	
		<b>Padlocking</b>	
2	4063 03	Support for one Ø5 mm padlock for DX <sup>3</sup> MCBs and RCDs or isolating switches	
3	4063 13	Ø5 mm shackle type padlock	
		<b>Spacing element</b>	
10	4063 07	For heat reduction – 0.5 module	

**Dimensions**

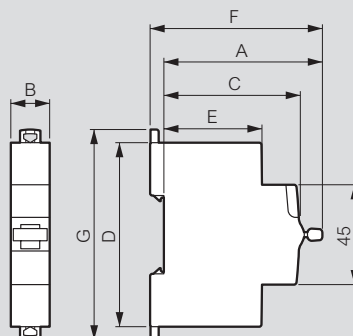

Description	Dimension (mm)										
	A	B				C	D	E	F	G	
	1P	1P+N	2P	3P	4P						
DX <sup>3</sup> MCBs up to 63 A	71.7	17.7	35.4	35.4	53.1	70.8	61	83	44	77.8	94.8
DX <sup>3</sup> MCBs from 80 A to 125 A	73.1	26.7	–	53.4	80.1	106.8	61	100	47	79	104.3
DX <sup>3</sup> RCDs	71.7	–	–	35.6	–	71.2	61	83	44	77.8	94.8
DX <sup>3</sup> RCBOs 1P (up to 45 A)	68	17.7	–	–	–	60	115	48	74	126.8	
DX <sup>3</sup> RCBOs 1P+N (up to 40 A) & 4P (up to 32 A)	71.7	–	35.6	–	–	71.2	61	83	44	77.8	94.8
DX <sup>3</sup> RCBOs 2P & 4P (40 A to 63 A)	72	–	–	71.2	–	124.6	61	96	44	78.2	107.8
DX <sup>3</sup> auxiliaries	71.5	8.8 / 17.7					61	83	44	77.7	84.5



# PUTTING MEASUREMENT AT THE HEART OF ENERGY EFFICIENCY

From MID<sup>1</sup> certified electricity meters and door mounted multi-functional displays, to remote web-based supervision software, Legrand's EMDX<sup>3</sup> metering range puts measurement at the heart of energy efficiency.



EMDX<sup>3</sup> UNIT - FOR DIN RAIL

## DIN rail mounted EMDX<sup>3</sup> measurement control units

Meter, measure, monitor and communicate all of the essential parameters of the installation on this DIN rail mounted module:

- Dual tariff metering
- Active and reactive energy
- Operating time
- Power factor
- Harmonic distortion
- Programmable alarms



EMDX<sup>3</sup> UNIT - FOR DOOR MOUNTING

## Door mounted EMDX<sup>3</sup> measurement control units

Meter, measure, monitor and communicate all of the essential parameters of the installation via a large display:

- Dual tariff metering
- Active and reactive energy
- Operating time
- Power factor
- Harmonic distortion
- Programmable alarms

For increased functionality, e.g. temperature/memory, additional modules are available. See p. 15

1: MID = Measuring Instruments Directive

## EMDX<sup>3</sup> electrical energy meters

└ rail mounting



Technical characteristics p. 18

Conform to standards :

- IEC 61557-12
- IEC 62053-21/23
- IEC 62052-11 and IEC 62052-31

Measure the electricity consumed by a single phase or three phase circuit downstream of the electricity distribution metering. Display electricity consumption in kWh, as well as other values such as current, active energy, reactive energy and power (depending on the catalogue number)

MID compliance ensures accuracy of the metering with a view to recharging for the electricity used

Pack	Cat. Nos.		Single phase meters				
	Non-MID	MID compliant					
1	0046 70		<b>Direct connection</b>	Maximum current (A)	Output type	Dual tariff	Number of modules
1	4120 68			32	Pulse	No	1
1		4120 69		45	RS 485	No	1
1	4120 80	4120 82		45	Pulse	No	1
1	4120 81	4120 83		63	Pulse	No	2
				63	RS 485	Yes	2

Pack	Cat. Nos.		Three phase meters				
	Non-MID	MID compliant					
1	4120 90 <sup>1</sup>	4120 92 <sup>1</sup>	<b>Direct connection</b>	Maximum current (A)	Output type	Dual tariff	Number of modules
1	4120 91	4120 93		63	Pulse	No	4
1	4120 74	4120 75		63	RS 485	Yes	4
				125	Pulse and RS 485	Yes	6
1	4120 40 <sup>1</sup>	4120 42 <sup>1</sup>	<b>Connection with CT</b>	5	Pulse	No	4
1	4120 41	4120 43		5	RS 485	Yes	4

Pack	Cat. Nos.	Pulse concentrator
1	4120 65	For collecting and transmitting measurements taken by 12 universal pulse electricity meters. Also collects pulses from other meters (gas meters, water meters, etc.) RS485 output 4 modules

Pack	Cat. Nos.	Measurement concentrator
1	4120 00	Full or partial electricity metering for 5 uses: heating, cooling, domestic hot water, and power sockets + "other" 5 inputs for current transformers <sup>2</sup> (up to 2 current transformers per input) 2 pulse inputs for water and gas metering LCD screen and 6 button keypad RJ45 IP output Power supply 110/230 VAC - 50/60 Hz 6 modules

Pack	Cat. Nos.	Split core current transformer
1	4120 02	90 A max. for the measurement concentrator Cat. No. 4120 00 Accepts : 10 x 1.5 mm <sup>2</sup> cables, or 7 x 2.5 mm <sup>2</sup> cables, or 2 x 6 mm <sup>2</sup> cables, or 1 x 10 or 16 mm <sup>2</sup> cable

Pack	Cat. Nos.	Solid core current transformer
1	4120 04	60 A, for the measurement concentrator Cat. No. 4120 00

## EMDX<sup>3</sup> multi-function measuring units

└ rail mounting



Technical characteristics p. 19

Conform to standards:

- IEC 61557-12
- IEC 62053-22
- IEC 62053-23

Pack	Cat. Nos.	EMDX <sup>3</sup> modular
1	4120 45	<b>Multi-function measuring unit</b> For mounting on └ rail Width: 4 modules • LCD display • Precision class: 1 • Connection with current transformers (CT) <sup>2</sup> • Measurement of currents, voltages, frequency, active, reactive and apparent power, power factor, active and reactive energy • THD voltages and currents • RS 485 and pulse output
1	4 120 51	<b>Multi-function measuring unit with active digital inputs and programmable alarms</b> For mounting on └ rail Width: 4 modules • LCD display • Precision class: 0.5 • Connection with current transformers (CT) <sup>2</sup> • Measurement of currents, voltages, frequency, active, reactive and apparent power, power factor, active and reactive energy • 4 tariff metering: • THD voltages, currents and harmonic analysis up to order 25 (available on Modbus COM port) • Programmable alarms on all functions • RS 485 and pulse output

1 : One pulse type input for other types of meters (gas, water, etc.)

2 : See current transformers on this page and also p. 16



# EMDX<sup>3</sup> multi-function measuring units



# EMDX<sup>3</sup> Supervision system



for mounting on door or solid faceplate



Technical characteristics p. 19

Conform to standards:

- IEC 61557-12
- IEC 62053-22
- IEC 62053-23 Class 1 for Cat. No. 4120 47

**EMDX<sup>3</sup> - Access multi-function measuring units**

Pack	Cat. Nos.	EMDX <sup>3</sup> - Access multi-function measuring units
1	4120 47	<p><b>Precision Class: 1</b></p> <p>For mounting on door or solid faceplate Dimensions: 96 x 96 x 62 mm</p> <ul style="list-style-type: none"> <li>• LCD display</li> <li>• Connection with current transformers (CT)</li> <li>• Measurement of currents, voltages, frequency, active, reactive and apparent power and power factor</li> <li>• Metering:                             <ul style="list-style-type: none"> <li>- Active energy consumed or produced</li> <li>- Reactive energy consumed or produced</li> <li>• THD voltages and currents</li> <li>• RS 485 communication and pulse output</li> </ul> </li> </ul>
1	4120 52	<p><b>Precision Class: 0-5</b></p> <p>For mounting on door or solid faceplate Dimensions: 96 x 96 x 62 mm</p> <ul style="list-style-type: none"> <li>• LCD display</li> <li>• Measurement of currents, voltages, active, reactive and apparent power and power factor</li> <li>• Metering:                             <ul style="list-style-type: none"> <li>- Active energy consumed or produced</li> <li>- Reactive energy consumed or produced</li> <li>- Operating time</li> <li>- Pulses</li> <li>• THD voltages, currents, and individual harmonic up to order 25<sup>1</sup></li> <li>• RS 485 communication and pulse output</li> </ul> </li> </ul>

**EMDX<sup>3</sup> - Premium multi-function measuring unit**

1	4120 53	<p>For mounting on door or solid faceplate Dimensions: 96 x 96 x 62 mm</p> <ul style="list-style-type: none"> <li>• LCD display</li> <li>• Precision class: 0-5</li> <li>• Measurement of currents, voltages, active, reactive and apparent power, internal temperature and power factor</li> <li>• Metering:                             <ul style="list-style-type: none"> <li>- Active energy consumed or produced</li> <li>- Reactive energy consumed or produced</li> <li>- Operating time</li> <li>- THD</li> <li>• Programmable alarms on all functions</li> <li>• Power quality functions: harmonics (U &amp; I) to 40th, dips, swells, interruption, rapid voltage change and flickers</li> <li>• Memory embedded (8 Mb)</li> <li>• RTC (real time clock)</li> </ul> </li> </ul> <p>Can take 4 EMDX<sup>3</sup> optional modules</p>
---	---------	---

**EMDX<sup>3</sup> modules**

Pack	Cat. Nos.	EMDX <sup>3</sup> - Premium multi-function measuring units
1	4120 55	R485 communication module with Modbus link
1	4120 59	Pulse output module for energy count
1	4120 57	2 independent and insulated outputs
1	4120 57	2 inputs / 2 outputs module
1	4120 60	Output can be assigned to alarms on different values
1	4120 60	2 analogue outputs module
1	4120 58	0...20 mA and/or 4...20 mA
1	4120 58	Temperature module
1	4120 58	2 Pt100 inputs resistances

Technical characteristics p. 19

Pack	Cat. Nos.	Energy management software for 1 computer (user licence key)	
1	4149 38	Allows remote configuration, test, control and visualisation of data collected from EMDX <sup>3</sup> electrical energy meters and multi-function measuring units and CX <sup>3</sup> energy management system on one computer connected to the network	
1	4149 39	Software licence agreement (user key) for 32 Modbus addresses or 32 pulse modules	
1	4149 39	Software licence agreement (user key) 255 Modbus addresses or 255 pulse modules	
<b>Energy management multi-support web servers</b>			
Allow remote configuration, test, control and visualisation, via a web browser on PCs, smartphones, web viewers, tablet computers, of data collected from: protection devices (DX <sup>3</sup> add-on modules with integrated measurement control unit, DPX <sup>3</sup> and DMX <sup>3</sup> ), EMDX <sup>3</sup> electricity meters and multi-function measuring units, CX <sup>3</sup> energy management system and Green'up charging stations for electric vehicles.			
<b>rail mounting</b>			
Direct IP connection			
Power supply: 9 to 28 V = with the help of a single phase switching mode power supply			
Cat. No. 1467 21 <sup>2</sup> to be ordered separately			
1	4149 47	For 10 Modbus addresses or 10 pulse modules	Number of modules: 4
1	4149 48	For 32 Modbus addresses or 32 pulse modules	4
1	4149 49	For 255 Modbus addresses or 255 pulse modules	
<b>Fixing on plate</b>			
Supplied with external power supply and fixing brackets			
<b>Communication interface</b>			
<b>RS485 / Ethernet</b>			
1	0046 89	For RS 485 / Ethernet conversion (for connection to an IP network)	Number of modules: 3

1 : Available on Modbus COM port

2 : For details of Cat. No. 1467 21, contact us on +44 (0) 370 608 9020

Current transformers (CT)  
p. 16



## Current transformers (CT)



4121 42



4121 58



4121 62

For information on current transformers technical characteristics contact us on **+44 (0) 370 608 9020**

Dimensions and technical information p. 17

Pack	Cat. Nos.	Single phase solid core current transformers																
		Used with ammeters, electricity meters or multi-function measuring units Current at the secondary: 5 A Can be fixed on plate, EN 60715 rail Cat. Nos. 4121 01/02/03/04/05/06/07, or bars Secondary connected by terminals or lugs Precision class: 0.5 % (1 % for Cat. Nos. 4121 01/02)																
		<b>For 16 x 12.5 mm bar or Ø21 mm cable</b>																
		<table border="1"> <thead> <tr> <th>Transformation ratio</th> <th>Output (VA)</th> </tr> </thead> <tbody> <tr><td>50/5</td><td>1.25</td></tr> <tr><td>75/5</td><td>1.5</td></tr> <tr><td>100/5</td><td>2</td></tr> <tr><td>125/5</td><td>2.5</td></tr> <tr><td>160/5</td><td>3</td></tr> <tr><td>200/5</td><td>4</td></tr> <tr><td>250/5</td><td>5</td></tr> </tbody> </table>	Transformation ratio	Output (VA)	50/5	1.25	75/5	1.5	100/5	2	125/5	2.5	160/5	3	200/5	4	250/5	5
Transformation ratio	Output (VA)																	
50/5	1.25																	
75/5	1.5																	
100/5	2																	
125/5	2.5																	
160/5	3																	
200/5	4																	
250/5	5																	
1	4121 01																	
1	4121 02																	
1	4121 03																	
1	4121 04																	
1	4121 05																	
1	4121 06																	
1	4121 07																	
		<b>For 32.5 x 10.5 and 25.5 x 15.5 mm bars or Ø27 mm cable</b>																
1	4121 12	400/5   10																
1	4121 14	600/5   12																
		<b>For 40.5 x 12.5 and 32.5 x 15.5 mm bars or Ø26 mm cable</b>																
1	4121 16	250/5   3																
1	4121 17	400/5   6																
1	4121 19	700/5   8																
		<b>For 40.5 x 10.5, 32.5 x 20.5 and 25.5 x 25.5 mm bars or Ø32 mm cable</b>																
1	4121 23	250/5   3																
1	4121 24	300/5   5																
1	4121 25	400/5   8																
1	4121 26	600/5   12																
		<b>For 50.5 x 12.5 and 40.5 x 20.5 mm bars or Ø40 mm cable</b>																
1	4121 31	700/5   8																
1	4121 32	800/5   8																
1	4121 33	1000/5   10																
		<b>For 65 x 32 mm bar</b>																
1	4121 36	600/5   8																
1	4121 38	800/5   12																
1	4121 39	1000/5   15																
		<b>For 84 x 34 mm bar</b>																
1	4121 42	1250/5   12																
		<b>For 127 x 38 mm bar</b>																
1	4121 46	1600/5   10																
1	4121 47	2000/5   15																
1	4121 49	3200/5   25																
		<b>For 127 x 54 mm bar</b>																
1	4121 50	1600/5   20																
1	4121 51	2000/5   25																
1	4121 52	2500/5   30																
1	4121 53	3200/5   30																
1	4121 54	4000/5   30																

Pack	Cat. Nos.	Three phase solid core current transformers				
		Used with ammeters, electricity meters or multi-function measuring units Current at the secondary: 5 A For fixing directly on bars Secondary connected by terminals or lugs Precision class: 1 %				
1	4121 57	<table border="1"> <thead> <tr> <th>Transformation ratio</th> <th>Output (VA)</th> </tr> </thead> <tbody> <tr><td>250/5</td><td>3</td></tr> </tbody> </table>	Transformation ratio	Output (VA)	250/5	3
Transformation ratio	Output (VA)					
250/5	3					
1	4121 58	<table border="1"> <thead> <tr> <th>Transformation ratio</th> <th>Output (VA)</th> </tr> </thead> <tbody> <tr><td>400/5</td><td>4</td></tr> </tbody> </table>	Transformation ratio	Output (VA)	400/5	4
Transformation ratio	Output (VA)					
400/5	4					
		<b>For three 20.5 x 5.5 mm bars</b>				
		<b>For three 30.5 x 5.5 mm bars</b>				
		<b>Single phase split-core current transformers</b>				
		Used with ammeters, electricity meters or multi-function measuring units Current at the secondary: 5 A For fixing directly on bars Secondary connected by terminals or lugs Precision class: 0.5 %				
		<b>For 50 x 80 mm bar</b>				
1	4121 62	400/5   1.5				
1	4121 63	750/5   3				
		<b>For 80 x 120 mm bar</b>				
1	4121 64	1000/5   5				
1	4121 65	1500/5   8				
		<b>For 80 x 160 mm bar</b>				
1	4121 66	2000/5   15				
1	4121 67	2500/5   15				
1	4121 68	3000/5   20				
1	4121 69	4000/5   20				

**For Viking 3 disconnecter blocks contact us on +44 (0) 370 608 9020**

# Current transformers (CT)

## technical characteristics

### ■ Dimensions

#### Single phase solid core current transformers

Cat. Nos. 4121 01/02/03/04/05/06/07

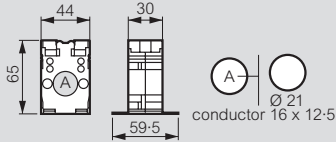

Cat. Nos. 4121 12/14

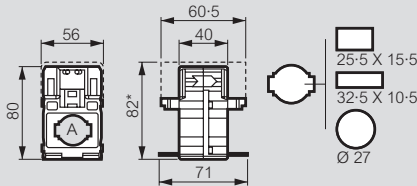

Cat. Nos. 4121 16/17/19

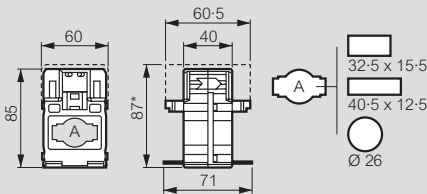

Cat. Nos. 4121 23/24/25/26

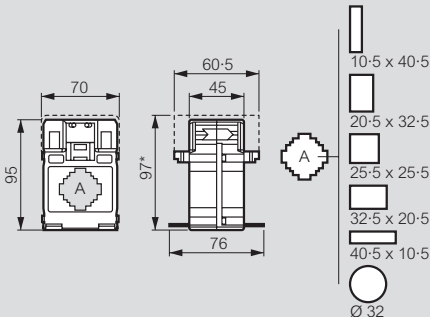

Cat. Nos. 4121 31/32/33

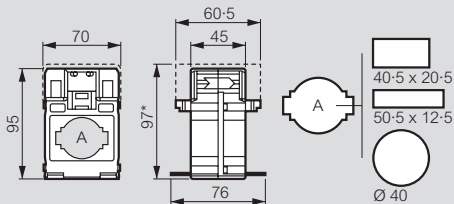

Cat. Nos. 4121 36/38/39/42/46/47/49/50/51/52/53/54

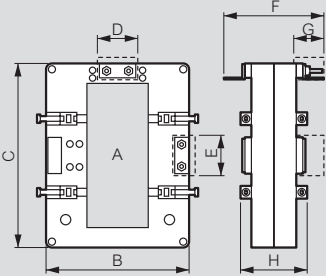

Cat. Nos.	A	B	C	D	E	F	G	H
4121 36/38/39	32 x 65	90	94	33.5	33.5	90	25	40
4121 42	34 x 84	96	116	33.5	33.5	87	25	40
4121 46/47/49	38 x 127	99	160	33.5	33.5	87	25	58
4121 50/51/52/53/54	54 x 127	125	160	33.5	33.5	87	25	40

\* : For more information contact us on 0370 608 9020

#### Single phase split core current transformers

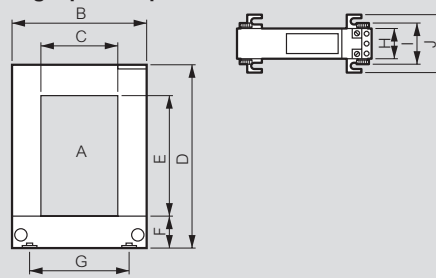

Cat. Nos.	A	B	C	D	E	F	G	H	I	J
4121 62/63	50 x 80	114	50	145	80	33	78	32	46	69
4121 64/65	80 x 120	144	80	185	121	32	108	32	46	69
4121 66/67/68/69	80 x 160	184	80	245	160	38	120	32	46	69

#### Three phase solid core current transformers

Cat. No. 4121 57 for three 20.5 x 5.5 mm bars

Cat. No. 4121 58 for three 30.5 x 5.5 mm bars

For fixing directly on bars

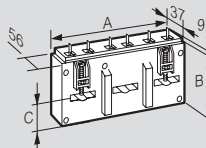

Cat. Nos.	A	B	C
4121 57	107	58.5	25
4121 58	135	66.5	30

#### ■ Maximum cable length between current transformers (CT) and meters

Size (A)	Cat. Nos.	Max. output		Maximum cable length between current transformers & meters (m)		
		Class 0.5 (VA)	Class 1 (VA)	Cable 1.5 mm <sup>2</sup>	Cable 2.5 mm <sup>2</sup>	Cable 6 mm <sup>2</sup>
50	4121 01		1.25	1.1	1.8	4.4
75	4121 02		1.5	1.5	2.4	5.9
100	4121 03	2		2.2	3.7	8.9
125	4121 04	2.5		2.9	4.9	11.8
160	4121 05	3		3.7	6.1	14.8
200	4121 06	4		5.1	8.5	20.7
250	4121 07	5		6.6	11.0	26.6
400	4121 12	10		13.9	23.2	56.2
600	4121 14	12		16.8	28.1	68.1
250	4121 16	3		3.7	6.1	14.8
400	4121 17	6		8.0	13.4	32.6
700	4121 19	8		11.0	18.3	44.4
250	4121 23	3		3.7	6.1	14.8
300	4121 24	5		6.6	11.0	26.6
400	4121 25	8		11.0	18.3	44.4
600	4121 26	12		16.8	28.1	68.1
700	4121 31	8		11.0	18.3	44.4
800	4121 32	8		11.0	18.3	44.4
1000	4121 33	10		13.9	23.2	56.2
600	4121 36	8		11.0	18.3	44.4
800	4121 38	12		16.8	28.1	68.1
1000	4121 39	15		21.2	35.4	85.8
1250	4121 42	12		16.8	28.1	68.1
1600	4121 46	10		13.9	23.2	56.2
2000	412 147	15		21.2	35.4	85.8
3200	4121 49	25		35.8	59.8	145.0
1600	4121 50	20		28.5	47.6	115.4
2000	4121 51	25		35.8	59.8	145.0
2500	4121 52	30		43.1	72.0	174.6
3200	4121 53	30		43.1	72.0	174.6
4000	4121 54	30		43.1	72.0	174.6
3 X 250	4121 57		3	3.7	6.1	14.8
3 X 400	4121 58		4	5.1	8.5	20.7
400	4121 62	1.5		1.5	2.4	5.9
750	4121 63	3		3.7	6.1	14.8
1000	4121 64	5		6.6	11.0	26.6
1500	4121 65	8		11.0	18.3	44.4
2000	4121 66	15		21.2	35.4	85.8
2500	4121 67	15		21.2	35.4	85.8
3000	4121 68	20		28.5	47.6	115.4
4000	4121 69	20		28.5	47.6	115.4

# EMDX<sup>3</sup> electrical energy meters

└ rail mounting

## Technical characteristics

Conform to IEC 61557-12

Active energy accuracy : Class 1 (EN 62053-21)  
 Class B (EN 50470-1,3) - for MID version  
 Reactive energy accuracy : Class 2 (EN 62053-23)

### Single phase meters :

Reference voltage  $U_n$  : 230 V-240 V  
 Reference frequency : 50-60 Hz

### Cat. Nos. 0046 70, 4120 68/69

LCD display : 7 digits  
 Resolution : 0.1 kWh  
 Maximum indication : 99999.9 kWh

### Cat. Nos. 4120 80/81/82/83

LCD graphic display : 9 digits  
 Resolution : 0.01 kWh  
 Maximum indication : 999999.99 kWh

### Three phase meters :

Reference voltage  $U_n$  : single phase 230 V-240 V  
 three phase 230 (400) - 240 (415) V

Reference frequency : 50-60 Hz

### Cat. Nos. 4120 40/41/42/43/90/91/92/93

LCD graphic display : 9 digits  
 Resolution : 0.01 kWh  
 Maximum indication : 999999.99 kWh

### Cat. Nos. 4120 74/75

LCD display : 8 digits  
 Resolution : 0.01 kWh  
 Maximum indication : 99999.99 kWh

Cat. Nos.		0046 70	4120 68	4120 69	4120 80	4120 81	4120 82	4120 83	4120 90	4120 91	4120 92	4120 93	4120 74	4120 75	4120 40	4120 41	4120 42	4120 43			
Type		Single phase								Three phase											
Connection		Direct connection																Connection via CT			
Number of modules		1	1	1	2	2	2	2	4	4	4	4	6	6	4	4	4	4			
Max. current (A)		32	45	45	63	63	63	63	63	63	63	63	125	125	5 (CT)	5 (CT)	5 (CT)	5 (CT)			
Metering and measurement	Energy	Total active energy	●	●	●	●	●	●	●	●	●	●	●	●	●	●	●	●	●		
		Total reactive energy		●		●	●	●	●	●	●	●	●	●	●	●	●	●	●		
		Partial active energy (reset)				●	●	●	●	●	●	●	●	●	●	●	●	●	●		
		Partial reactive energy (reset)				●	●	●	●	●	●	●	●	●	●	●	●	●	●		
	Energy bidirectional measure	Ea + and Ea - by tariff				●	●	●	●	●	●	●	●			●	●	●	●		
		Power	Active power		●		●	●	●	●	●	●	●	●	●	●	●	●	●	●	
	Reactive power			●		●	●	●	●	●	●	●	●	●	●	●	●	●	●		
	Apparent power			●		●	●	●	●	●	●	●	●	●	●	●	●	●	●		
	Average active power			●		●	●	●	●	●	●	●	●	●	●	●	●	●	●		
	Max. average active power value					●	●	●	●	●	●	●	●	●	●	●	●	●	●		
	Electrical values	Current		●		●	●	●	●	●	●	●	●	●	●	●	●	●	●		
		Voltage		●		●	●	●	●	●	●	●	●	●	●	●	●	●	●		
		Frequency		●		●	●	●	●	●	●	●	●	●	●	●	●	●	●		
		Power factor		●		●	●	●	●	●	●	●	●	●	●	●	●	●	●		
Dual tariff					●	●	●	●	●	●	●	●	●	●	●	●	●	●			
Pulse input					●	○	●	○	●	○	●	○			●	○	●	○			
Connection diagnostic															●	●	●	●			
Time of uses	Total				●	●	●	●	●	●	●	●	●	●	●	●	●	●			
	By tariff				●	●	●	●	●	●	●	●	●	●	●	●	●	●			
Communication	Pulse output	●		●	●	●	●	●	●	●	●	●	●	●	●	●	●	●			
	Modbus RS 485		●		●	●	●	●	●	●	●	●	●	●	●	●	●	●			
MID certification				●			●	●			●	●					●	●			

● Built-in function  
 ○ Dual tariff or pulse input

## Interfacing with IP communication network

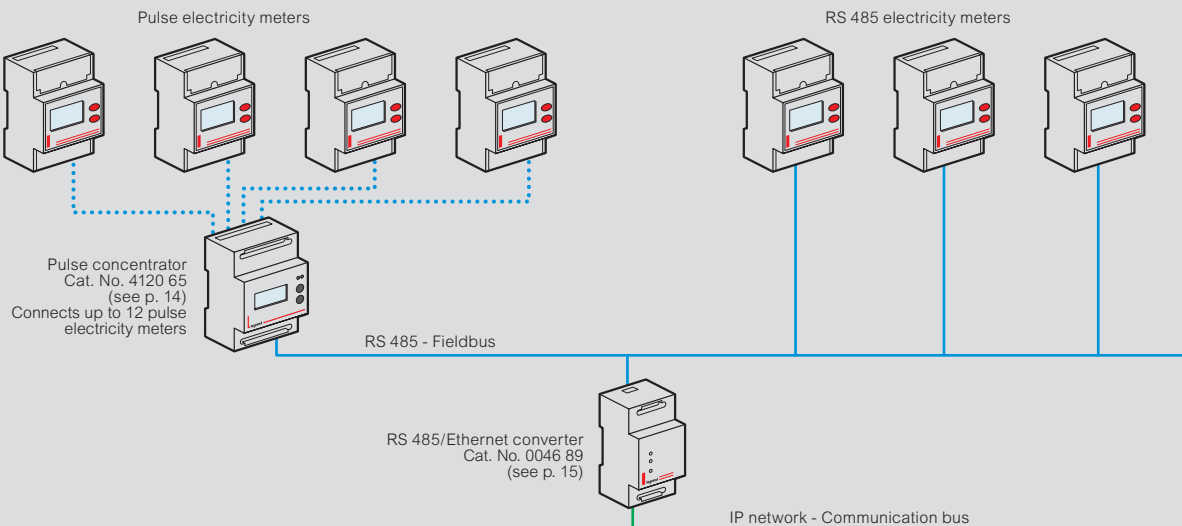

# EMDX<sup>3</sup> multi-function measuring units

└ rail mounting and for mounting on door or solid faceplate

## Technical characteristics

Cat. Nos.			4120 45	4120 47	4120 51	4120 52	4120 53	
Connection	Current measurement terminals	Flexible cable	4 mm <sup>2</sup>	4 mm <sup>2</sup>	4 mm <sup>2</sup>	4 mm <sup>2</sup>	4 mm <sup>2</sup>	
		Rigid cable	6 mm <sup>2</sup>	6 mm <sup>2</sup>	6 mm <sup>2</sup>	6 mm <sup>2</sup>	6 mm <sup>2</sup>	
	Other terminals	Flexible cable	2.5 mm <sup>2</sup>	2.5 mm <sup>2</sup>	2.5 mm <sup>2</sup>	2.5 mm <sup>2</sup>	2.5 mm <sup>2</sup>	
		Rigid cable	4 mm <sup>2</sup>	4.5 mm <sup>2</sup>	4 mm <sup>2</sup>	4 mm <sup>2</sup>	4 mm <sup>2</sup>	
Protection index	Front cover	IP 54					IP 54	IP 54
	Casing	IP 20					IP 20	IP 20
Weight			250 g	285 g	250 g	285 g	285 g	
Display	Type	Backlit LCD					Backlit LCD	Backlit LCD
	Refresh time	1.1 s		1.1 s	1 s	1 s	1 s	
Measurements			1P+N, 3P, 3P+N	1P+N, 3P, 3P+N	1P+N, 3P, 3P+N	1P+N, 3P, 3P+N	1P+N, 3P, 3P+N	
Voltage measurement	Direct	Phase/Phase	80 - 500 V	50 - 460 V	80 - 500 V	80 - 500 V	80 - 690 V	
		Phase/Neutral	50 - 290 V	86 - 260 V	50 - 290 V	50 - 290 V	50 - 400 V	
	From PT	Primary	-	-	max. 1200 V	max. 1200 V	max. 150 kV	
		Secondary	-	-	-	-	-	
Update period			0.8 s	0.3 s	0.2 s	0.2 s	0.2 s	
Current measurement	Direct						-	-
		From a CT	Primary	50 kA	50 kA	max. 10 kA (X/1 A) or 50 kA (X/5A)	max. 10 kA (X/1 A) or 50 kA (X/5A)	max. 10 kA (X/1 A) or 50 kA (X/5A)
		Secondary	5 A	5 A	1 A or 5 A	1 A or 5 A	1 A or 5 A	
	Minimum measurement			10 mA	10 mA	5 mA	5 mA	
	Input consumption			≤ 1 VA	≤ 1 VA	≤ 1 VA	≤ 0.2 VA	
	Permanent overload			1.2 In	1.2 In	1.2 In	1.2 In	
	Intermittent overload			20 In / 0.5 s	20 In / 0.5 s	20 In / 0.5 s	20 In / 0.5 s	
	Update period			0.2s	0.2s	0.2s	0.2 s	
	Max. CT x PT ratio			9999	9999	99990	99990	10000000 (x/1 A) / 2000000 (x/5 A)
	Power measurement	Total			0 - 9999 kW/ kVA / kVA	0 - 9999 kW/ kVA / kVA	0 - 9999 kW/ kVA / kVA 0 - 9999 MW / MVA / MVA	0 - 9999 kW/ kVA / kVA 0 - 9999 MW / MVA / MVA
Update period				0.2 s	0.2 s	0.2 s	0.2 s	
Frequency measurement	Measurement range			45/65 Hz	45/65 Hz	45/65 Hz - 360/440 Hz	45/65 Hz	
	Update period			0.2 s	0.2 s	0.2 s	0.2 s	
Auxiliary power supply	50 / 60 Hz			230 V ± 10%	Self-supplied	80 - 265 V ± 10%	80 - 265 V ± 10%	
	d.c.			-	-	100 - 300 V ± 10%	100 - 300 V ± 10%	
	Consumption	a.c.	≤ 2.5 VA	≤ 2.5 VA	≤ 2.5 VA	≤ 2.5 VA	≤ 2.5 VA	
	d.c.			-	-	≤ 3.5 W	≤ 3.5 W	
Operating temperature			from -5° C to +55° C	from -5° C to +55° C	from -5° C to +55° C	from -5° C to +55° C	from -5° C to +55° C	
Storage temperature			from -25° C to +70° C	from -25° C to +70° C	from -25° C to +70° C	from -25° C to +70° C	from -25° C to +70° C	

## Maximum number of modules and installing position for multi-function measuring unit Cat. No. 4120 53 (see p. 15)

Cat. Nos.	Designation	Max. number	EMDX <sup>3</sup> -Premium 4120 53
4120 55	RS 485 communication module	1	A
4120 57	2 inputs / 2 outputs module	2	C, D
4120 58	Temperature module	1	D
4120 59	Pulse output module for energy count	2	A, B, C, D
4120 60	2 analog outputs module	2	C, D

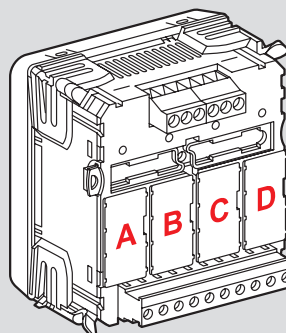

## Fitting modules Cat. No. 4120 53 (see p. 15)

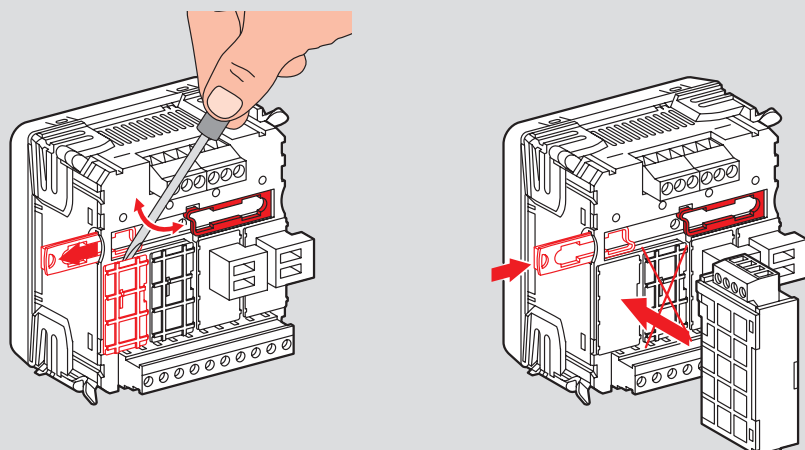

# modular fuse carriers

for industrial cylindrical cartridge fuses

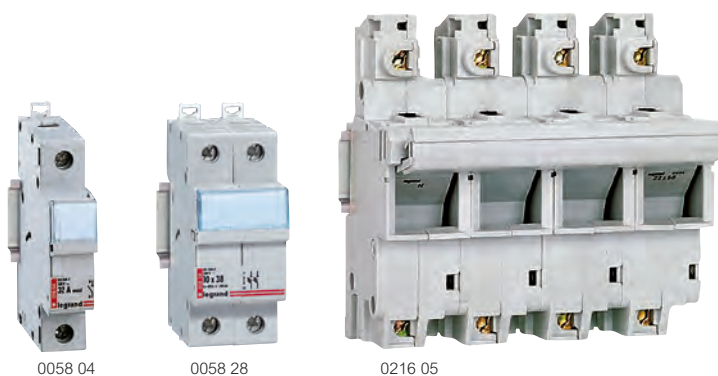

Dimensions **opposite**  
Accessories **p. 21**

For HRC cylindrical fuses (see p. 22)

Pack	Cat. Nos.	Modular carriers for HRC type aM and gG fuses		
		Conform to IEC 60269-2/2-1, isolation to IEC 60947-3 Fix to DIN rail EN 60715 Equipped with label holder Padlockable using locking accessory Cat. No. 0057 99, p. 21 Shielded terminals max. capacity 2 x 10 mm <sup>2</sup> Double insulated Class II		
		Fuse size (mm)	Voltage ~ (Volts)	No. of 17.5 mm modules
		<b>Single pole</b>		
10	0058 04	Disconnectable neutral	500	1
10	0058 06	8.5 x 31.5	400	1
10	0058 08	10 x 38	500	1
		<b>Single pole + Neutral</b>		
10	0058 16	8.5 x 31.5	400	1
10	0058 18	10 x 38	500	1
		<b>Double pole</b>		
5	0058 28	10 x 38	500	2
		<b>Triple pole</b>		
3	0058 38	10 x 38	500	3
		<b>Triple pole + Neutral</b>		
2	0058 48	10 x 38	500	4

SP isolating fuse carriers with protected terminals				
For isolation and protection of electrical circuits Conform to IEC 60269-2 and BS EN 60269-2 Bureau Veritas approved Height under front plate : 44 mm Fix to DIN rail EN 60715 or with screws				
<b>SP 51 for HRC type aM and gG fuses 14 x 51</b>				
		Connection	No. of 17.5 mm modules	
5	0215 01	Single pole	1 x 35 mm <sup>2</sup>	1-5
1	0215 03	Double pole	or	3
1	0215 04	Triple pole	2 x 16 mm <sup>2</sup>	4-5
1	0215 05	Triple pole + disconnectable neutral		6
<b>SP 58 for HRC type aM and gG fuses 22 x 58</b>				
		Connection	No. of 17.5 mm modules	
3	0216 00	Disconnectable neutral	1 x 50 mm <sup>2</sup>	2
3	0216 01	Single pole	or	2
1	0216 04	Triple pole	2 x 25 mm <sup>2</sup>	6
1	0216 05	Triple pole + disconnectable neutral		8

## Modular fuse carriers

Conform to IEC 60269-2/2-1, isolation to IEC 60947-3  
Icc : 20 kA with 8.5 x 31.5 fuse  
100 kA with 10 x 38 fuse  
Operating temperature : -5 °C to +40 °C  
Mechanical resistance : IPXX 3

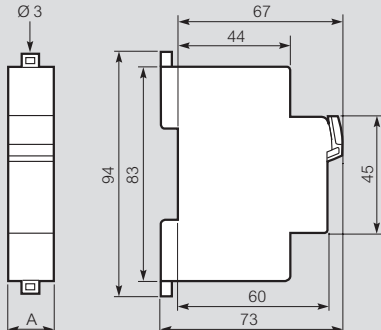

In mm	A
Single pole	17.7
Single pole + N	17.7
Double pole	35.5
Triple pole	53.4
Triple pole + N	71.2

## SP 51 and SP 58 fuse carriers

Conform to IEC 60269-2 and BS EN 60269-2  
Bureau Veritas approved

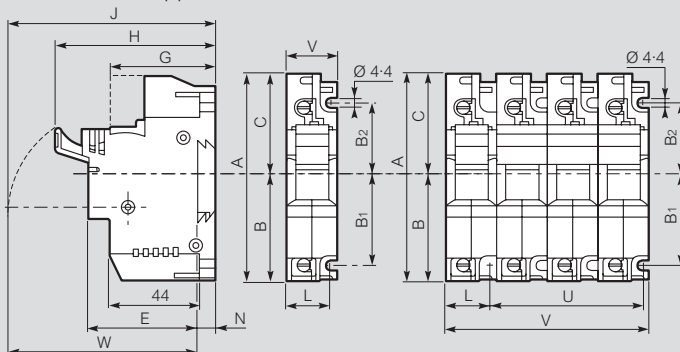

In mm	A	B	B <sub>1</sub>	B <sub>2</sub>	C	E	G	H 1 P	H multi.	J 1 P
SP 51	106	54.5	45	35	51.5	55	53	81	84	96
SP 58	140	74	65	45	66	59	53	87	90	111

In mm	J multi.	L	N	U 2 P	U 3 P	U 4 P	V 1 P	V 2 P	V 3 P	V 4 P	W 1 P	W multi.
SP 51	99	20.7	9	26.5	53	79.5	26.5	53	79.5	106	87	90
SP 58	114	27	9	36	72	108	36	72	108	144	101	109

## Choice of equipment

Type	Rated current	Maximum cartridge rating			
		400 V ~		500 V ~	
		gG	aM	gG	aM
SP 51	50 A	50	50	50	40
SP 58	100 A (125 A in 400 V)	125	125	100	50

**Protection index** : IP 2X - IP 2X C - under front plate

## Equipment derating

Justified under more severe conditions of use :

- Ambient temperature over 35 °C : derate fuse by one rating per 10 °C (UTE C 20-051)
- Side-by-side equipment in simultaneous function

2 or 3 devices	0.9 x I <sub>n</sub>
4 or 5 devices	0.8 x I <sub>n</sub>
6, 7, 8 or 9 devices	0.7 x I <sub>n</sub>
≥ 10 devices	0.6 x I <sub>n</sub>

This coefficient is to be applied on the nominal rating of the base (IEC 60439-1)  
• Continuous operation : it may be necessary to upgrade the bases by one size

## Modular protective terminal shield mounting (see p.21)

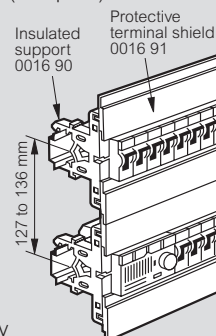

# modular fuse carriers and device accessories



4049 05

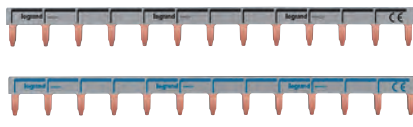

4049 26



4049 89



0016 91



0016 90

Pack	Cat. Nos.	Modular fuse carrier accessory
3	0057 99	Padlock support suitable for Ø 5 mm padlocks
<b>Modular device accessories</b>		
10	4063 07	<b>Spacing elements</b> For heat reduction - 0.5 module
2	4063 03	<b>Locking device</b> Attachment for Ø 5 mm padlocks for DX <sup>3</sup>
3	4063 13	<b>Padlock</b> Ø 5 mm
20	4049 05	<b>Entry terminals</b> Accepts conductors 4-25 mm <sup>2</sup> max for single pole busbars only IP 2X
20	4049 06	Accepts conductors 6-35 mm <sup>2</sup> max
20	4049 26	<b>Supply busbars</b> For 13 single pole units <sup>1</sup> Reversible blue/black
10	4049 37	For 57 single pole units <sup>1</sup> Reversible blue/black
5	4049 38	For 6 double pole units <sup>2,3</sup>
10	4049 39	For 28 double pole units <sup>2,3</sup>
5	4049 42	For 4 triple pole units <sup>2,3</sup>
10	4049 43	For 19 triple pole units <sup>2,3</sup>
3	4049 44	For 3 four pole units <sup>2,3</sup>
20	4049 88	<b>Insulation shroud</b> For non-utilised busbar prongs
40	4049 89	<b>SP busbar end cover</b> For single pole / single pole + neutral supply busbars Cat. Nos. 4049 26/37
10	0049 96	<b>Self-adhesive label holder</b> Width : 16 mm Width available for marking : 12 mm Length 430 mm (24 modules)
10	0016 65	<b>Grey blanking plate RAL 7035</b> 18 module, blanking strip

Pack	Cat. Nos.	Modular device accessories (continued)
5	0016 91	<b>Protective terminal shield</b> Light grey Ensures the protection of wiring and terminals in modular mechanisms fitted in enclosures (Atlantic or Marina <sup>4</sup> ) Width 45 mm. Length 1 m Clips on to support 0016 90 (below)
10	0016 90	<b>Insulated support</b> For protective terminal shield Clips on to rail EN 60715

1 : 16 mm<sup>2</sup> section rated at 80 A with central feed  
 2 : 10 mm<sup>2</sup> section rated at 63 A with central feed  
 3 : With insulated ends  
 4 : For Atlantic and Marina enclosures  
 contact us on +44 (0) 370 608 9020

DX<sup>3</sup> MCBs p. 4-5



For the Legrand range of Atlantic and Marina enclosures see our Industrial Plugs, Sockets & Enclosures guide [www.legrand.co.uk](http://www.legrand.co.uk)



# cylindrical cartridge fuses

HRC



Dimensions **p. 25**

Numbers refer to physical size of fuse i.e. 10 x 38 means Ø 10 mm x 38 mm length

**Pack**   **Cat. Nos.**   **Miniature type 5 x 20**

Pack	Cat. Nos.	Rating (Amps)	Voltage ~ (Volts)	Breaking capacity (Amps)
	Type F (fast acting) fuse Ceramic body Conform to IEC 60127-2 For use with transformers (see p. 34)			
10	0102 02	0.2		
10	0102 05	0.5		
10	0102 06	0.63		
10	0102 10	1		
10	0102 12	1.25		
10	0102 16	1.6		
10	0102 20	2	250	1 500
10	0102 25	2.5		
10	0102 30	3.15		
10	0102 50	5		
10	0102 63	6.3		
10	0102 96 <sup>1</sup>	10	250	500

**Type gG**

Pack	Cat. Nos.	Rating (Amps)	Voltage ~ (Volts)	Breaking capacity (Amps)
	Conform to BS EN 60269-1, IEC 60269-1 Bureau Veritas approved			
	Without indicator			
	<b>8 x 32</b>			
10	0123 01	1		
10	0123 02	2		
10	0123 04	4		
10	0123 06	6		
10	0123 08	8	400	20 000
10	0123 10	10		
10	0123 12	12		
10	0123 16	16		

**For use with Viking 3 terminals**

**Pack**   **Cat. Nos.**   **Type gG industrial**

Pack	Cat. Nos.	Rating (Amps)	Voltage ~ (Volts)	Breaking capacity (Amps)
	HRC (high rupturing capacity) Conform to BS EN 60269-1 and 2 (BS 88) IEC 60269-1, 2 and 2-1 Bureau Veritas approved			
	Without indicator			
	<b>10 x 38</b>			
10	0133 94	0.5		
10	0133 01	1		
10	0133 02	2		
10	0133 04	4		
10	0133 06	6	500	100 000
10	0133 08	8		
10	0133 10	10		
10	0133 12	12		
10	0133 16	16		
10	0133 20	20		
10	0133 25	25		
	Without striker			
	<b>14 x 51</b>			
10	0143 02	2		
10	0143 04	4		
10	0143 06	6		
10	0143 10	10		
10	0143 16	16	500	100 000
10	0143 20	20		
10	0143 25	25		
10	0143 32	32		
10	0143 40	40		
10	0143 50	50		
	Without striker			
	<b>22 x 58</b>			
10	0153 10	10		
10	0153 16	16		
10	0153 20	20		
10	0153 25	25	500	100 000
10	0153 32	32		
10	0153 40	40		
10	0153 50	50		
10	0153 63	63		
10	0153 80	80		
10	0153 96	100	400	
10	0153 97	125		

**Neutral links**

10	0123 00	8 x 32
10	0133 00	10 x 38
10	0143 00	14 x 51
10	0153 00	22 x 58

1 : Overrating not described by standards

For the Legrand range of Viking 3 terminals see our Industrial Plugs, Sockets & Enclosures guide [www.legrand.co.uk](http://www.legrand.co.uk)





# cylindrical cartridge fuses

## HRC (continued)

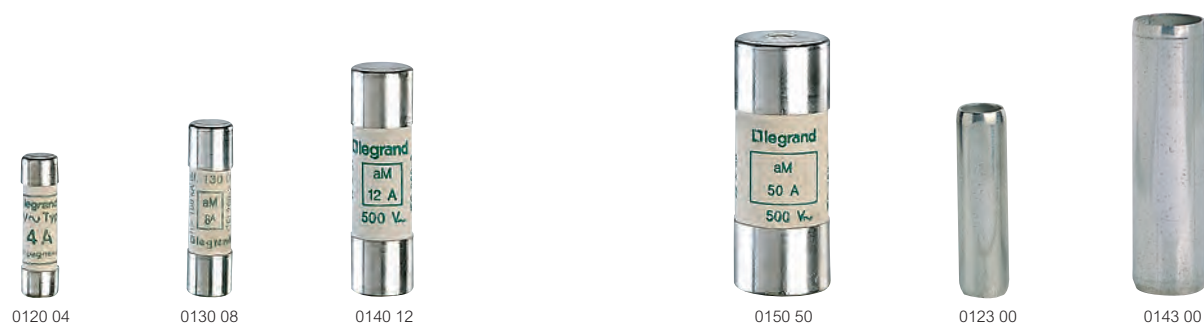

Dimensions p. 25

Numbers refer to physical size of fuse i.e. 10 x 38 means Ø 10 mm x 38 mm length

Pack	Cat. Nos.	Cylindrical type aM (motor rated)		
		Conform to BS EN 60269-1 (BS 88) IEC 60269-1 Bureau Veritas approved		
		Rating (Amps)	Voltage ~ (Volts)	Breaking capacity (Amps)
	Without indicator	<b>8 x 32</b>		
10	0120 02	2	400	20 000
10	0120 04	4		
10	0120 06	6		
10	0120 10	10		
		HRC (high rupturing capacity) Conform to BS EN 60269-1 and IEC 60269-1, 2 and 2-1 Bureau Veritas approved		
	Without indicator	<b>10 x 38 HRC</b>		
10	0130 95	0.5	500	100 000
10	0130 01	1		
10	0130 02	2		
10	0130 04	4		
10	0130 06	6		
10	0130 08	8		
10	0130 10	10		
10	0130 12	12		
10	0130 16	16		
10	0130 20 <sup>1</sup>	20		
10	0130 25 <sup>1</sup>	25	400	
	Without striker	<b>14 x 51 HRC</b>		
10	0140 04	4	500	100 000
10	0140 06	6		
10	0140 10	10		
10	0140 12	12		
10	0140 16	16		
10	0140 20	20		
10	0140 25	25		
10	0140 32	32		
10	0140 40	40		
10	0140 45 <sup>2</sup>	45		
10	0140 50 <sup>2</sup>	50	400	

Pack	Cat. Nos.	Cylindrical type aM (motor rated) (continued)		
		HRC (high rupturing capacity) Conform to BS EN 60269-1 (BS 88) IEC 60269-1, 2 and 2-1 Bureau Veritas approved		
		Rating (Amps)	Voltage ~ (Volts)	Breaking capacity (Amps)
	Without striker	<b>22 x 58 HRC</b>		
10	0150 32	32	500	100 000
10	0150 40	40		
10	0150 50	50		
10	0150 63	63		
10	0150 80	80		
10	0150 96	100		
10	0150 97 <sup>2</sup>	125	400	
		<b>Neutral links</b>		
10	0123 00	8 x 32		
10	0133 00	10 x 38		
10	0143 00	14 x 51		
10	0153 00	22 x 58		

1 : Overrating not described by standards  
2 : Overrating described by standards

# HRC blade type cartridge fuses

## gG/aM type



Dimensions p. 25

Pack	Cat. Nos.	Type gG (IEC)/gL (VDE)		
		HRC (high rupturing capacity) Conform to BS EN 60269-1 and 2, IEC 60269-1, 2 and 2-1, VDE 0636-21 Bureau Veritas approved Fully insulated end plate and handle lugs		
		With indicator	Rating (Amps)	Voltage ~ (Volts)
				Breaking capacity (Amps)
		<b>Size 00</b>		
10	0163 18		25	500
10	0163 20		32	
10	0163 25		40	
10	0163 30		50	
10	0163 35		63	
10	0163 40		80	
10	0163 45		100	
10	0163 50		125	
10	0163 55		160	
		<b>Size 0</b>		
3	0168 45		100	500
3	0168 50		125	
3	0168 55		160	
3	0168 60 <sup>1</sup>		200	
		<b>Size 1</b>		
3	0173 50		125	500
3	0173 55		160	
3	0173 60		200	
3	0173 65		250	
		<b>Size 2</b>		
3	0178 60		200	500
3	0178 65		250	
3	0178 70		315	
3	0178 75		400	

Pack	Cat. Nos.	Type aM (motor rated)		
		HRC (high rupturing capacity) Conform to BS EN 60269-1 and 2, IEC 60269-1, 2 and 2-1, VDE 0636-21 Bureau Veritas approved Fully insulated end plate and handle lugs		
		With indicator	Rating (Amps)	Voltage ~ (Volts)
				Breaking capacity (Amps)
		<b>Size 00</b>		
3	0160 25		40	500
3	0160 30		50	
3	0160 35		63	
3	0160 40		80	
3	0160 45		100	
3	0160 50		125	
		<b>Size 0</b>		
3	0165 35		63	500
3	0165 40		80	
3	0165 45		100	
3	0165 50		125	
3	0165 55		160	
		<b>Size 1</b>		
3	0170 50		125	500
3	0170 55		160	
3	0170 60		200	
3	0170 65		250	
		<b>Size 2</b>		
3	0175 60		200	500
3	0175 65		250	
3	0175 70		315	

**Neutral blades**

1	0168 04	Size 0
1	0173 04	Size 1
1	0178 04	Size 2
1	0181 04	Size 3

**Handle**

5	0199 02	Removable handle for all sizes
---	---------	--------------------------------

1 : Overrating not described by standards

# cartridge fuses

## dimensions

### Cylindrical fuses (p. 22-23)

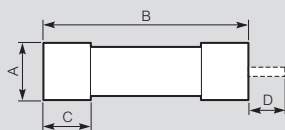

Size	A	B	C	D
8 x 32 (mm)	8.5	31.5	6.3	-
10 x 38 (mm)	10.3	38	10	-
14 x 51 (mm)	14.3	51	13	7.5
22 x 58 (mm)	22.2	58	16	7.5

### Blade type fuses (p. 24)

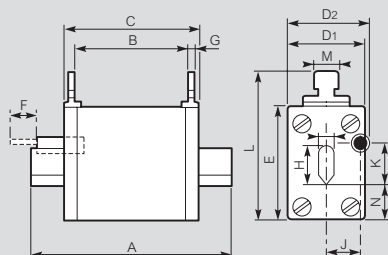

Size	00	0	1	2
A (mm)	78	125	135	150
B (mm)	44	62	64	64
C (mm)	52	67	74	74
D <sub>1</sub> (mm)	30	36	47	50
D <sub>2</sub> (mm)	-	39	47	50
E (mm)	46	46	52	60
F (mm)	-	14	14	14
G (mm)	2.5	2.5	3	3
H (mm)	15	15	21	28
I (mm)	6	6	6	6
J (mm)	-	14.5	16	19
K (mm)	-	14.5	14.5	14.5
L (mm)	59	59	64	72
M (mm)	10	10	10	10
N (mm)	14.5	14.5	14.5	14.5

### Neutral blades (p. 24)

Sizes 0 to 3

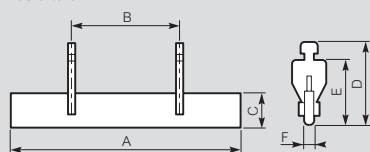

Size	0	1	2	3
A (mm)	125	135	150	150
B (mm)	65	65	65	65
C (mm)	15	20	26	38
D (mm)	45	50	58	66.5
E (mm)	35	40	48	56.5
F (mm)	6	6	6	6

### Removable handle (p. 24)

For sizes 00 - 0 - 1 - 2

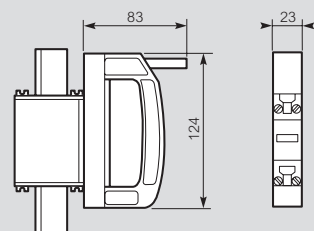

# ISOLATION, CONTROL AND SIGNALLING

Developments within Legrand's isolation, control and signalling range include new DX<sup>3</sup> switch disconnectors which boast the same design improvements as DX<sup>3</sup> MCBs, RCDs, RCBOs (see p. 4-12), and in addition new CX<sup>3</sup> contactors which are available with or without handle.



**DX<sup>3</sup> SWITCH DISCONNECTORS**

**FEATURES**

- Double break contacts
- Locking possible in open and closed position

**TECH DATA**

Category of use: AC 22A / 23A  
 Current rating: 16A to 125A  
 Rated voltage: 250V / 400V

Vistop switch disconnectors also available.  
 see p. 28-30

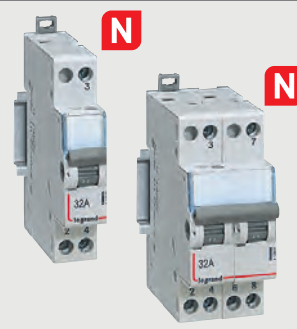

**CHANGEOVER SWITCHES**

**FEATURES**

- Locking accessories available
- Two way, double two way and two way with centre point options

**TECH DATA**

Category of use: AC 22A  
 Nominal rating: 20A  
 Rated voltage: 250V / 400V

see p. 31

## DX<sup>3</sup>... next generation DIN rail devices

Switch disconnectors, MCBs, RCDs, RCBOs, control and signalling auxiliaries... the guarantee of finding the function you need with a uniform appearance and optimised dimensions.

See pages 2-3 to find out more about the new DX<sup>3</sup> range

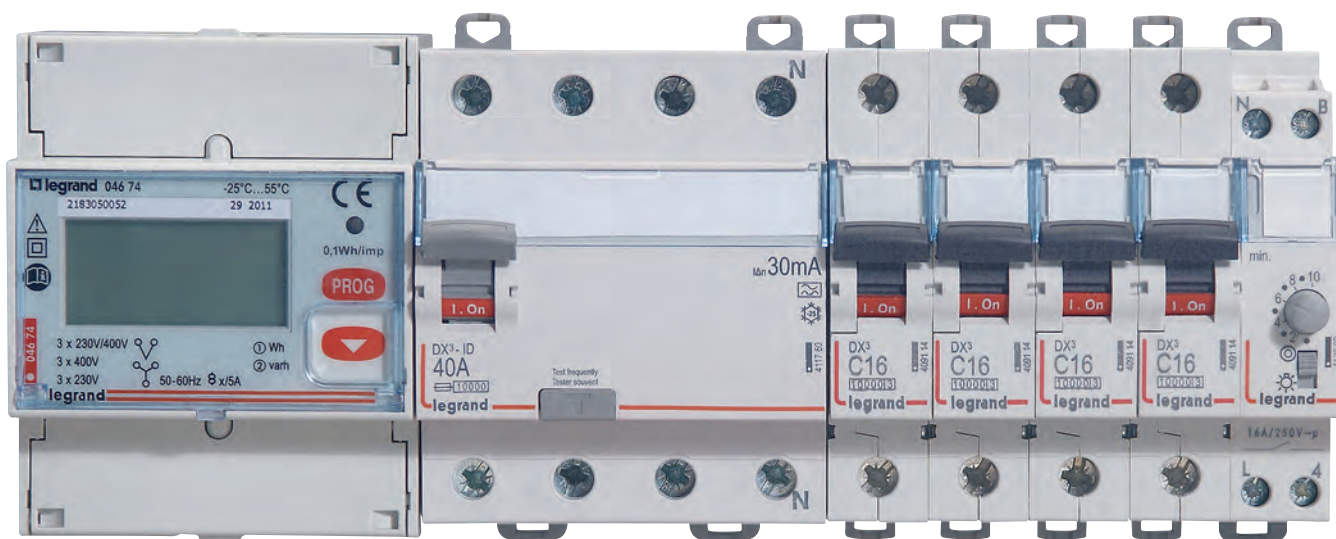

THE FIGHT AGAINST COUNTERFEIT... MANY DX<sup>3</sup> PRODUCTS ARE MARKED WITH A UNIQUE REGISTRATION NUMBER. VISIT [WWW.LEGRAND-COPYTRACER.COM](http://WWW.LEGRAND-COPYTRACER.COM)



### PUSH BUTTONS, CONTROL SWITCHES AND LED INDICATORS

#### FEATURES

- Nominal rating 20 A - 250 VA
- Compatible with fluorescent lamps (20 AX)
- Accept prong-type supply busbars

For further information see p. 45



### TRANSFORMERS AND POWER SUPPLIES

#### FEATURES

- Control, signalling and safety isolation transformers
- Compact transformers
- Filtered power supplies

For further information see p. 34 to 41



### CX<sup>3</sup> POWER CONTACTORS

#### FEATURES

- Contact choice: N/O - normally open  
N/C - normally closed
- Easy fixing of control and auxiliaries ensures optimum strength
- Available with or without handle
- Independent screw connection / wiring of control and power terminals at any one time

For further information see p. 42 to 44



### TIME SWITCHES

#### FEATURES

- Digital and analogue versions available
- DIN rail and surface mounting options
- AlphaRex<sup>3</sup> programmable range

For further information see p. 50 to 57

# It's a push button, it's a control switch... you decide

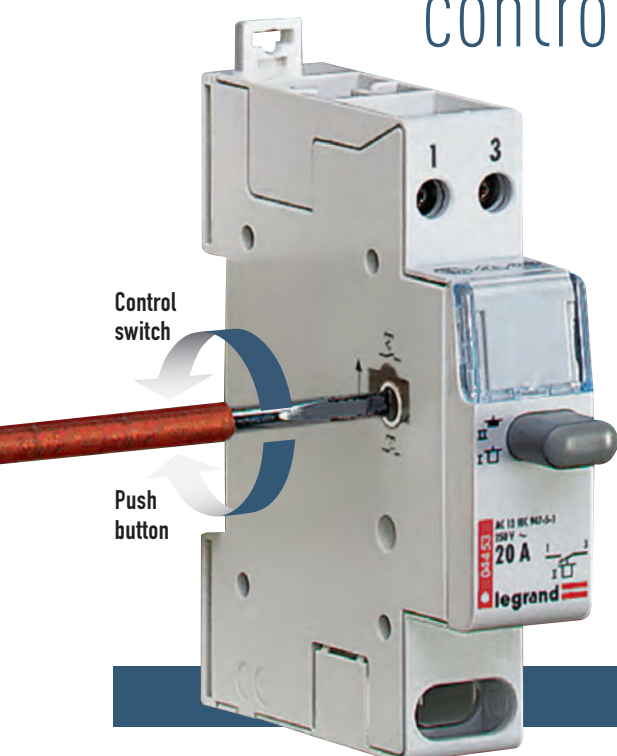

Turn a momentary contact into a maintained contact at the turn of a button with Legrand's versatile push button / control switches.

Available with normally open (N/O), normally closed (N/C) or both N/O and N/C contacts, and in single function or dual function with indicators.

GO TO PAGE 45 TO FIND OUT MORE

# DX<sup>3</sup>-IS switch disconnectors

16 to 125 A



4064 59



4064 81

Dimensions **p. 47**  
 Technical information **opposite**

AC 23 A according to BS EN 60947-3 and IEC 60947-3, AC 22 A for 125 A  
 Double break contacts  
 Visible contact indicator

Pack	Cat. Nos.	Switch disconnectors
		Grey handle Can be equipped with 1 DX <sup>3</sup> signalling auxiliary (p. 6) Lock in open and closed position with locking device Cat. No. 4063 03 and Ø 5 mm padlock Cat. No. 4063 13 Label holder for circuit identification
		<b>1P - 250 V<math>\sim</math></b>
		Nominal rating I <sub>n</sub> (A)
10	4064 00	16
10	4064 01	20
10	4064 03	32
10	4064 11	40
10	4064 12	63
10	4064 23	100
		Number of modules
		16: 1
		20: 1
		32: 1
		40: 1
		63: 1
		100: 1
		<b>2P - 400 V<math>\sim</math></b>
10	4064 31	16
10	4064 32	20
10	4064 34	32
5	4064 40	40
5	4064 41	63
5	4064 53	63 with red handle
5	4064 55	100 with red handle
5	4064 50	125
		Number of modules
		16: 1
		20: 1
		32: 1
		40: 2
		63: 2
		63 with red handle: 2
		100 with red handle: 2
		125: 2
		<b>2P with indicator - 400 V<math>\sim</math></b>
		Supplied with lamp Do not accept auxiliaries
10	4064 36	20
10	4064 38	32
		Number of modules
		20: 1
		32: 1
		<b>3P - 400 V<math>\sim</math></b>
5	4064 57	20
5	4064 59	32
1	4064 60	40
1	4064 61	63
1	4064 75	100 with red handle
1	4064 70	125
		Number of modules
		20: 2
		32: 2
		40: 3
		63: 3
		100 with red handle: 3
		125: 3
		<b>4P - 400 V<math>\sim</math></b>
5	4064 77	20
5	4064 79	32
1	4064 80	40
1	4064 81	63
1	4064 95	100 with red handle
1	4064 90	125
		Number of modules
		20: 2
		32: 2
		40: 4
		63: 4
		100 with red handle: 4
		125: 4

## Accessories

2	4063 03	<b>Padlocking</b> Support for one Ø5 mm padlock for DX <sup>3</sup> MCBs and RCDs or switch disconnectors	
3	4063 13	Ø5 mm shackle type padlock	
2	4063 04	<b>Sealable screw cover - 4 separable poles</b> For DX <sup>3</sup> switch disconnectors 1 module per pole	
1	4063 05	<b>Insulating shields</b> For DX <sup>3</sup> switch disconnectors 1 module per pole Pole insulating shield (set of 6)	

## DX<sup>3</sup>-IS switch disconnectors

### Electrical characteristics

Thermal rating (I <sub>th</sub> )	16 - 40 A	40 - 63 A	100 - 125 A
	0.5 module/pole	1 module/pole	1 module/pole
Terminals	Cage	Cage	Cage
Connection	flexible	1.5 to 10 mm <sup>2</sup>	1.5 to 25 mm <sup>2</sup>
	rigid	1.5 to 16 mm <sup>2</sup>	1.5 to 35 mm <sup>2</sup>
Insulation voltage (Hi)	500 V $\sim$	500 V $\sim$	500 V $\sim$
Impulse withstand voltage (U <sub>imp</sub> )	6 kV	6 kV	6 kV
Category of use <sup>1</sup>	AC 22 A	AC 22 A	AC 22 A
Short time withstand current (I <sub>cw</sub> )	750 A	2000 A	2500 A
Short-circuit making capacity (I <sub>cm</sub> )	1500 A	3000 A	3700 A
No. of electrical operations	30000	20000	5000
Protection index	IP 2X wired	IP 2X wired	IP 2X wired

<sup>1</sup> : test conditions according to IEC 60947-3  
 AC 22 A : combined motor/resistor breaking with frequent operations

## Dimensions

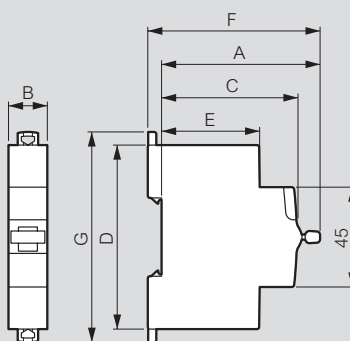

Description	Dimension (mm)										
	A	B			C	D	E	F	G		
	1P	1P+N	2P	3P	4P						
Switch disconnectors DX <sup>3</sup>	71.7	17.8	-	17.8/ 35.4	35.6/ 53.1	35.6/ 70.8	61	83	44	77.8	94.8

# Vistop™ switch disconnectors

63 to 160 A



0225 15

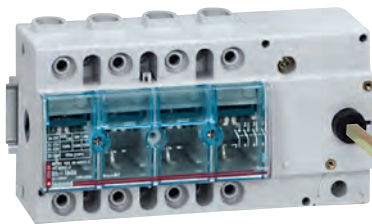

0225 53



0227 32



0227 98

Dimensions and technical information p. 30

Conform to BS EN 60947-3

Bureau Veritas approved

Safety switches for on-load circuit breaking by visible isolation of the contacts

Double break type load switching with self cleaning contacts by rapid make and break movements

Fixing on rail EN 60715 or screw fixing (only on rail for Vistop 63 A)

2 versions for mounting on faceplate : direct front handle or external handle with Cat. No. 0227 32

Pack	Cat. Nos.	Vistop switch disconnectors with black handle - 63 to 160 A		
		Possibility to add auxiliary contact Cat. No. 0227 07		
	Front handle			
1	0225 12	<b>63 A</b>	Connection	Number of 17.5 mm modules
1	0225 15	3P	Cage terminals	7
		4P		7
		<b>100 A</b>		
1	0225 20	3P	Key	7.5
1	0225 22	4P	6 sides	9
		<b>125 A</b>		
1	0225 34	3P	Key	7.5
1	0225 39	4P	6 sides	9
		<b>160 A</b>		
1	0225 51	3P	Key	7.5
1	0225 53	4P	6 sides	9

Pack	Cat. Nos.	Auxiliary switch disconnectors 2 pole - 16 A - 400 V		
		For creating 3 or 4 pole assemblies for simultaneous breaking of 2 pole auxiliary power supply (PLC, remote control), 16 A maximum		
		Mounts on the left side of Vistop 100 to 160 A		
1	0227 22	2P	Connection Cage terminals	Number of 17.5 mm modules 1.5
		<b>Sealable terminal shields</b>		
1	0227 98	Set of 2 separate, sealable terminal shields Clip on upstream and/or downstream of Vistop 160 A		

Pack	Cat. Nos.	Front external handle kit		
1	0227 32	Comprising : connection rod, bracket, self-adhesive drilling template, fixing accessories (including a seal to maintain the IP protection of enclosure up to IP 55) and locking mechanism to prevent opening of the door when the circuit is closed Door distance 35 to 470 mm		

Pack	Cat. Nos.	Auxiliary switches for on-off signalling IP 2X - 5 A - 250 V		
		<b>N/O + N/C contact</b>		
		For incorporation in one-piece enclosure		
1	0227 04	Main contact		
		2 N/C + 2 N/O mounting		
1	0227 07	Additional N/C + N/O auxiliary contact	Connection (mm <sup>2</sup> )	
		2 N/C + 2 N/O mounting		
			lug 2.58	

Changeover switches p. 31  
Fuse carriers p. 20



# Vistop™ switch disconnectors

63 to 160 A (continued)

Conform to standards BS EN 60947-3, EN / IEC 60947-3, VDE 0660, NBN EN 60947-3, CNOMO E03 - 15-611 R, Bureau Veritas approved Glass fibre reinforced insulating casing, self-extinguishing at 960 °C (IEC EN 60695-2-1)  
Handle can be padlocked in open position using 1 to 3 padlocks Ø6 mm

## Electrical characteristics

Thermal rating (I <sub>th</sub> )	63 A	100 A	125 A	160 A
Terminals	cage	cage	cage	cage
Connection	Cu (flexible)	4 to 35 <sup>2</sup>		4 to 50 mm <sup>2</sup>
	Cu (rigid)	4 to 50 <sup>2</sup>		4 to 70 mm <sup>2</sup>
Insulating voltage (U <sub>i</sub> )	690 V $\sim$	800 V $\sim$	800 V $\sim$	800 V $\sim$
Impulse resistant voltage (U <sub>imp</sub> )	8 kV	8 kV	8 kV	8 kV
AC 22 A <sup>1</sup>	400 V	63 A (35 kW)	100 A (55 kW)	125 A (70 kW)
	500 V	63 A (44 kW)	100 A (69 kW)	125 A (87 kW)
		160 A (110 kW)		
AC 23 A <sup>1</sup>	690 V	40 A (38 kW)	100 A (96 kW)	125 A (120 kW)
		160 A (120 kW)		
DC 22 A/250 V <sup>1,2</sup>	63	100	125	125
DC 23 A/250 V <sup>1,2</sup>	63	100	125	125
Breaking capacity (I <sub>cu</sub> ) (kA peak)	15	15	15	15
1 s resistant current (I <sub>cw</sub> ) (kA rms)	2.5	3.5	3.5	3.5
I <sub>cc</sub> with fuses (kA rating)	100	100	100	80
Fuse rupture capacity	63 A	100 A (gG) 63 A (aM) <sup>3</sup>	125 A (gG) 125 A (aM) <sup>3</sup>	160 A (gG) 125 A (aM)
Short circuit capacity (I <sub>cm</sub> ) (kA prospective peak)	7	12	12	12
Mechanical endurance (No. of operations)	> 30000	> 30000	> 30000	> 30000
Index of protection	IP 2X B (IP 3X C under front plates) from 6 mm <sup>2</sup>	IP 2X B (IP 3X C under front plate) from 10 mm <sup>2</sup>		

1 : Test according to IEC 60947-3  
AC 22 A / DC 22 A : resistive motor breaking  
AC 23 A / DC 23 A : inductive motor breaking  
2 : No of breaking contacts : 2  
3 : 100 A (aM) with blade type cartridge fuses

## Example of mounting with Vistop 100 to 160 A

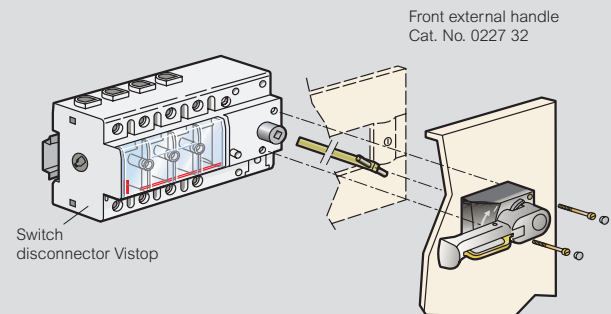

## Dimensions

### Front handle 63 to 160 A

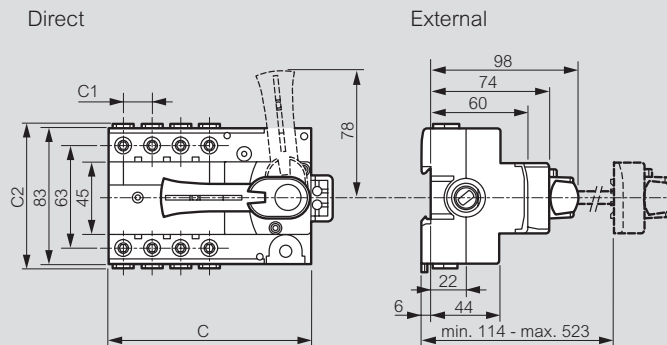

	Front handle		
	63 A	100 A, 125 A, 160 A	
	3P and 4P		
C	125	133	160
C <sub>1</sub>	17.7	26.7	
C <sub>2</sub>	90	91	



# CX<sup>3</sup> changeover switches **N**

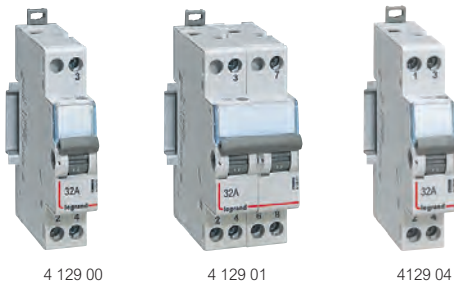

Dimensions and technical information **opposite**

Pack	Cat. Nos.	Changeover switches	Number of modules
		Conform to IEC 60669-1 Nominal rating 32 A Compatible with fluorescent lamps (20 AX)	
		<b>Two way - 250 V<math>\sim</math></b>	
10	4129 00	Connection Number of modules: 1	1
5	4129 01	<b>Double two way - 400 V<math>\sim</math></b>  Number of modules: 2	2
10	4129 02	<b>Two way with centre point - 250 V<math>\sim</math></b>  Number of modules: 1	1
5	4129 03	<b>Double two way with centre point - 250 V<math>\sim</math></b>  Number of modules: 2	2
10	4129 04	<b>Switch NO + NC - 250 V<math>\sim</math></b>  Number of modules: 1	1

Pack	Cat. Nos.	Accessories
2	4063 03	<b>Padlocking</b> Support for one $\varnothing$ 5 mm padlock
3	4063 13	$\varnothing$ 5 mm shackle type padlock



## Protection index

Class II  $\square$   
IP 2X protection against direct contact

## Characteristics

### • Technical characteristics

Power dissipation per pole : 1.5 W  
Overvoltage category : 4 kV $\sim$   
Dielectric withstand : 2 kV $\sim$   
Degree of pollution : 2

### • Environmental conditions

Operating temperature : -5 °C to +40 °C

## Dimensions

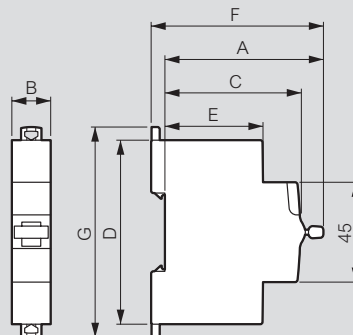

Description	Dimension (mm)										
	A	B				C	D	E	F	G	
	1P	1P+N	2P	3P	4P						
CX <sup>3</sup> changeover switches	68	17.8	-	35.6	-	-	60	83	44	74	94

## Installation

### • Mounting

- on symmetrical rail EN 50-022
- with  $\varnothing$ 3 mm screw on plate using ends of released claws
- supply via the top or the bottom
- operating position : vertical

### • Wiring

Conductors permitted	
Flexible with end caps	1.5 to 4 mm <sup>2</sup>
Rigid	1.5 to 4 mm <sup>2</sup>
Tools required :	
Flat blade screwdriver	$\varnothing$ 4 mm
Posidrive screwdriver	Pz 1
Tightening torque	
Min.	0.8 Nm
Max.	1.8 Nm
Recommended	1.2 Nm

# TRANSFORMERS AND POWER SUPPLIES

the reliable choice

Specifically designed to meet the needs of control and signalling, isolation and safety isolation, Legrand's open type single phase transformers are suited to a multitude of applications.

The offer is complemented by a range of filtered power supplies, specifically for 12 or 24 V DC applications.



## MEETING THE STANDARDS



CONTROL &  
SIGNALLING  
IEC / EN 61558-2-2



ISOLATING  
IEC / EN 61558-2-4



SAFETY ISOLATING  
IEC / EN 61558-2-6



## CONTROL, SIGNALLING AND ISOLATION TRANSFORMERS

Ideal for heavy automation systems, industrial process systems and complex machinery.

### FEATURES

- Primary tapping +/- 15 V
- 40 VA to 4000 VA
- Permanent laser engraved markings
- DIN rail mounting or mounting plate fixing
- Integral electrostatic shield
- Interference/disturbance filter
- Visible terminals ensure safe and reliable connections
- Supplied complete with voltage links

### TECHNICAL DATA

APPROVALS: IEC/EN 61558-2-2, IEC/EN 61558-2-4,  
IEC/EN 61558-2-6, UL, CSA

PROTECTION: IP2X up to 400 A, IK04

OPERATING TEMPERATURE: up to 50° C without derating

RECOMMENDED PROTECTION: via a gG type fuse or by  
C type circuit breaker

see p. 34-35

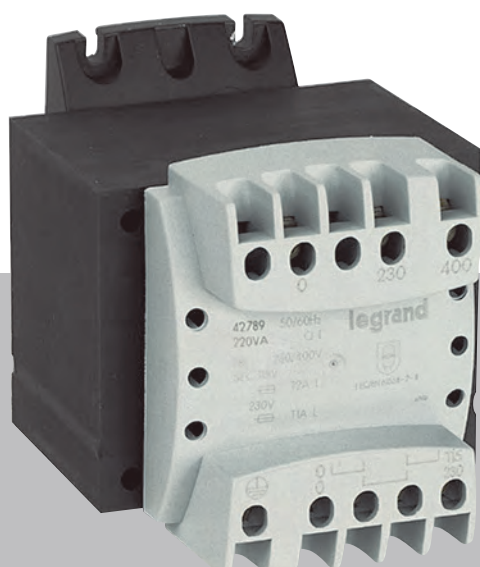

## COMPACT TRANSFORMERS

Ideal for standard systems where compact dimensions are a key installation requirement.

### FEATURES

- Fixed secondary voltage: 24 V range
- 40 VA to 630 VA
- Noise filtering up to 220 VA
- Permanent laser engraved markings
- Multiple fixing options: standard plate mounting  
DIN rail mounting optional
- Visible terminals ensure safe and reliable connections
- Supplied complete with voltage links

### TECHNICAL DATA

APPROVALS: IEC/EN 61558-2-4, IEC/EN 61558-2-6

OPERATING TEMPERATURE: up to 35° C without derating

RECOMMENDED PROTECTION: Type T fuses for 40 VA and 63 VA  
Type C MCBs for 100 VA and greater

see p. 36-39

## FILTERED POWER SUPPLIES

A range of filtered power supplies for PLCs and other equipment requiring a voltage of 12 V DC or 24 V DC.

### FEATURES

- Ripple factor < 3%
- Twin output terminals for ease of connection
- DIN rail or mounting plate fixing
- Noise filtering
- Integrated secondary fuse protection
- Supplied with busbar for quick connection between neutral and earth (up to 15 V)

### TECHNICAL DATA

APPROVALS: IEC/EN 61558-2-6, UL, CSA

OPERATING TEMPERATURE: Up to 60° C without derating  
see p. 40-41

# control, signalling and safety isolation transformers

## open type single phase



0442 35



0442 68



0442 71

Dimensions and technical information **p. 35**

IP 2X or IP XXB up to 400 VA  
 IP XXA above 400 VA - IK 04  
 Conform to IEC/EN 61558-2-2 and 2-4 or 2-6  
 UL506 and CSA C22-2-N°66  
 Products suitable for building into equipment conforming to EN 61131-2, EN 60204-1 and EN 61439 standards  
 Insulated covers up to 1 000 VA provided  
 Interference/disturbance filter included  
 Screw fix to mounting plate or clip on to DIN rail up to 250 VA  
 and direct panel mount  
 Supplied with 0V/Earth connection link up to 1 000 VA

Pack	Cat. Nos.	Single phase		
		<b>Primary : 230-400 V ± 15 V</b>		
		<b>Secondary : 24-48 V</b>		
		Supplied with 2 links		
		Power in VA according to IEC and CSA	Power in VA according to UL	Admissible instantaneous power at cos φ = 0.5
1	0442 31	40	40	52
1	0442 32	63	63	87
1	0442 33	100	100	150
1	0442 34	160	140	250
1	0442 35	250	210	420
1	0442 36	400	300	900
1	0442 37	630	500	1 700
1	0442 38	1 000	700	2 000
1	0442 39	1 600	700	8 500
1	0442 40	2 500	1 400	3 300

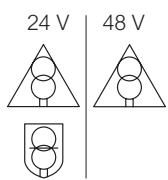

### Secondary protection

Transformers can be protected by a gG type fuse **p. 22** or by a C type circuit breaker **p. 4**

Pack	Cat. Nos.	Single phase		
		<b>Safety isolating transformers</b>		
		<b>Primary : 230-400 V ± 15 V</b>		
		<b>Secondary : 115-230 V</b>		
		Supplied with 2 links		
		Power in VA according to IEC and CSA	Power in VA according to UL	Admissible instantaneous power at cos φ = 0.5
1	0442 61	40	40	50
1	0442 62	63	63	86
1	0442 63	100	100	150
1	0442 64	160	140	250
1	0442 65	250	210	430
1	0442 66	400	300	1 200
1	0442 67	630	500	1 600
1	0442 68	1 000	700	2 000
1	0442 69	1 600	700	6 100
1	0442 70	2 500	1 300	7 100
1	0442 71	4 000	2 400	11 400

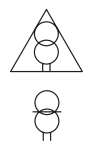

# control, signalling and safety isolation transformers

## open type single phase (continued)

### Dimensions

Fig. 1 : 40 to 400 VA

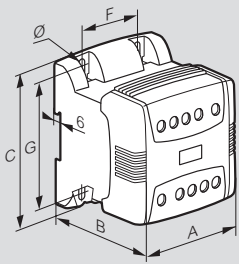

Fig. 2 : 630 to 1 000 VA

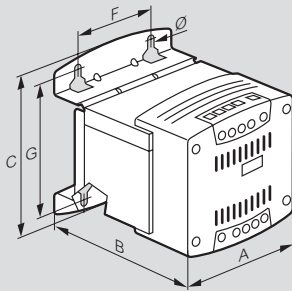

Fig. 3 : 1 600 to 2 500 VA

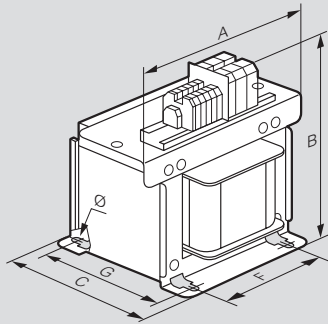
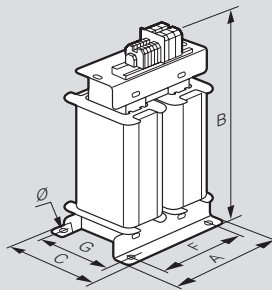

Fig. 4 : 4 000 to 8 000 VA



### Electrical characteristics

Single phase 50-60 Hz - Class 1

Insulation voltage between windings : 4 510 V

Maximum ambient operating temperatures : 50 °C without derating

### Voltage adjustment

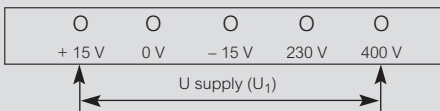

- if  $U_1 > 230$  or  $400$  V
- if  $I_2 < I_{2n}$  (if the load is less than the nominal load reduce the secondary voltage)

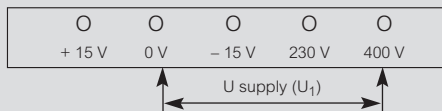

- if  $U_1 = 230$  or  $400$  V with load  $I_2 = I_{2n}$

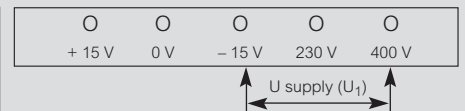

- if  $U_1 < 230$  or  $400$  V with load  $I_2 = I_{2n}$

Cat. Nos.	Power (VA)	Admissible instantaneous power (VA) at $\cos \varphi$ of :									No-load loss (W)	On-load loss <sup>1</sup> (W)	Voltage drop as (%) with $\cos \varphi$ :			Efficiency (%) with $\cos \varphi$ :			Ucc (%)	Connection capacity			
		0.2	0.3	0.4	0.5	0.6	0.7	0.8	0.9	1			0.3	0.6	1	0.3	0.6	1		Primary cable (mm <sup>2</sup> )		Secondary cable (mm <sup>2</sup> )	
Primary 230-400 V $\pm$ 15 V - Secondary 24-48 V																							
0442 31	40	63	58	55	52	50	48	48	49	60	3.9	7.3	8.7	10.5	8.5	62	77	84	10.0	1 to 4	1 to 4	1 to 4	1 to 4
0442 32	63	110	102	94	87	83	79	77	78	91	6.0	14.2	7.5	9.4	8.5	57	73	82	9.0	1 to 4	1 to 4	1 to 4	1 to 4
0442 33	100	200	180	160	150	140	130	130	130	150	8.2	15.1	7.3	9.3	8.9	66	80	87	8.9	1 to 4	1 to 4	1 to 4	1 to 4
0442 34	160	340	300	270	250	230	220	210	210	230	11.2	24.6	5.8	7.6	7.7	66	80	87	7.2	1 to 4	1 to 4	1 to 4	1 to 4
0442 35	250	550	490	450	420	400	380	370	370	430	14.9	31.4	5.2	6.6	6.2	70	83	89	6.1	1 to 4	1 to 4	1 to 4	1 to 4
0442 36	400	1800	1300	1100	900	800	700	600	600	500	18.3	46.3	2.1	3.7	5.6	72	84	90	4.2	1 to 4	1 to 4	1 to 4	1 to 4
0442 37	630	2700	2200	1900	1700	1500	1300	1200	1200	1200	24.1	49.4	2.0	3.0	3.9	79	88	93	3.3	1 to 16	1 to 16	1 to 16	1 to 16
0442 38	1000	3400	2800	2300	2000	1800	1600	1500	1400	1300	44.2	74.4	1.3	1.9	2.9	80	89	93	2.4	1 to 16	1 to 16	1 to 16	1 to 16
0442 39	1600	12800	10900	9500	8500	7700	7100	6700	6400	6600	65.5	94.7	1.1	1.6	1.9	84	91	94	1.7	2.5 to 10	1.5 to 16	4 to 16	1.5 to 25
0442 40	2500	4300	3900	3600	3300	3100	3000	2900	2900	3400	86.5	143.4	1.8	2.2	2.0	84	91	95	1.9	4 to 16	1.5 to 25	4 to 35	2.5 to 50
Primary 230-400 V $\pm$ 15 V - Secondary 115-230 V																							
0442 61	40	62	57	53	50	48	47	46	47	57	3.9	7.4	8.7	10.5	8.8	62	76	84	10.1	1 to 4	1 to 4	1 to 4	1 to 4
0442 62	63	110	100	93	86	82	78	76	76	90	6.0	11.8	7.6	9.6	8.9	62	76	84	9.2	1 to 4	1 to 4	1 to 4	1 to 4
0442 63	100	200	180	160	150	140	140	130	130	150	8.2	17.3	7.2	9.2	8.6	63	78	85	8.7	1 to 4	1 to 4	1 to 4	1 to 4
0442 64	160	330	300	270	250	240	230	220	220	250	11.2	23.4	5.8	7.4	7.1	67	80	87	6.9	1 to 4	1 to 4	1 to 4	1 to 4
0442 65	250	560	510	460	430	410	390	380	370	430	14.9	31.7	5.2	6.6	6.2	70	83	89	6.1	1 to 4	1 to 4	1 to 4	1 to 4
0442 66	400	2200	1700	1400	1200	1000	910	830	760	730	18.3	43.9	2.1	3.6	5.2	73	85	90	4.1	1 to 4	1 to 4	1 to 4	1 to 4
0442 67	630	2700	2200	1800	1600	1400	1200	1100	1000	1000	24.1	53.2	2.1	3.3	4.5	78	88	92	3.6	1 to 16	1 to 16	1 to 16	1 to 16
0442 68	1000	3400	2800	2300	2000	1800	1600	1500	1400	1300	44.2	73.6	1.3	2.0	2.7	80	89	93	2.2	1 to 16	1 to 16	1 to 16	1 to 16
0442 69	1600	8700	7500	6600	6100	5400	5000	4700	4500	4700	65.5	95.3	1.1	1.5	1.8	83	91	94	1.5	2.5 to 10	1.5 to 16	2.5 to 10	1.5 to 16
0442 70	2500	9200	8300	7600	7100	6700	6300	6200	6100	7100	86.5	150.1	1.8	2.3	2.2	83	91	94	2.0	4 to 16	1.5 to 25	4 to 16	1.5 to 25
0442 71	4000	16500	14300	12700	11400	10500	9800	9200	8900	9500	87.4	234.8	2.1	2.9	3.3	84	91	94	2.7	4 to 16	1.5 to 25	4 to 16	1.5 to 25

1 : Total losses at nominal load

### Fixing

On perforated plates

On symmetrical rail up to 250 VA

fixing centres pitch 25 mm up to 1000 VA

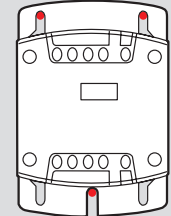
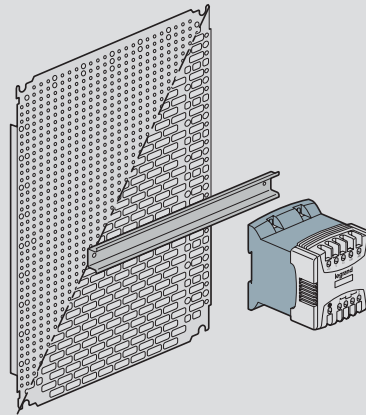

Oblong fixings : Attachment at 3 points possible

Cat. Nos.	Power (VA)	Fig.	Dimensions (mm)			Fixing <sup>1</sup> (mm)			Weight (Kg)
			A	B	C	F	G	Ø	
0442 31/61	40	1	94	78	113	50	100	5.2	1.23
0442 32/62	63	1	94	85	113	50	100	5.2	1.56
0442 33/63	100	1	94	94	113	50	100	5.2	1.95
0442 34/64	160	1	94	112	113	50	100	5.2	2.6
0442 35/65	250	1	106	123	115	50	100	5.2	3.82
0442 36/66	400	1	120	140	140	62.5	125	5.2	5.62
0442 37/67	630	2	150	158	206	100	175	7	9.9
0442 38/68	1000	2	150	199	206	100	175	7	14.9
0442 39/69	1600	3	220	245	191	150	153	9	25.6
0442 40/70	2500	3	300	292	171	200	114	9	33.1
0442 71	4000	4	230	340	205	180	130	11	31

Note : 40-250 VA transformers have juxtaposed windings with an insulated barrier to provide insulation and interference filtering. Higher ratings have an electrostatic screen between windings

1 : Up to 250 VA may be fixed to symmetrical DIN rail

# compact transformers

## open type single phase

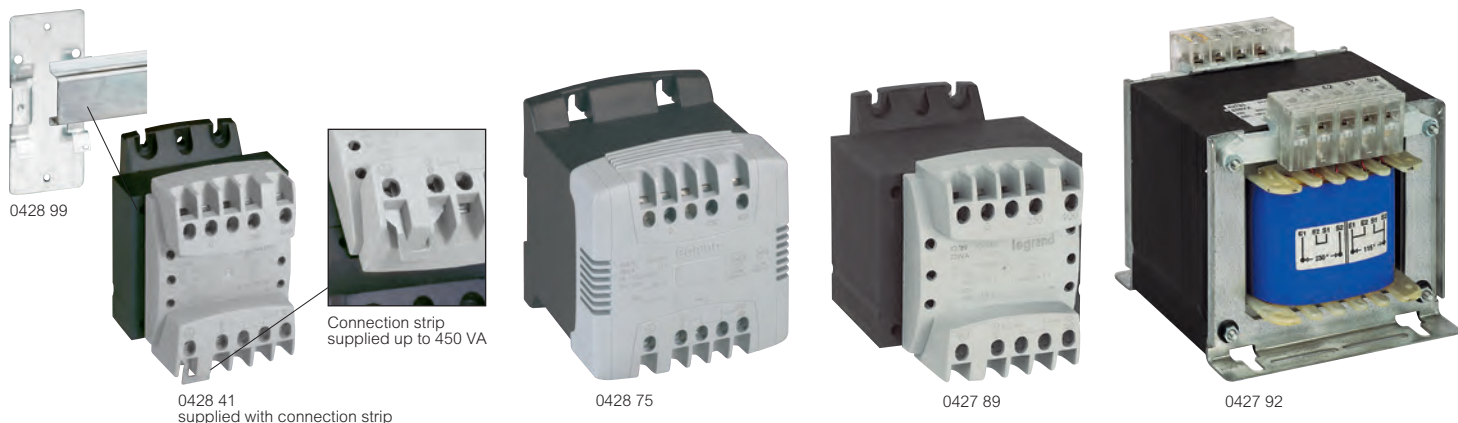

Technical information and dimensions **p. 37**  
Transformer protection **p. 39**

IP 2X or IP XXB up to 250 VA - IK 04  
Conform to IEC/EN 61558-2-4 and IEC/EN 61558-2-6  
Isolating and safety isolating <50 V transformers  
Designed to meet the needs of users with specific VA ratings such as original equipment manufacturers  
Terminals are designed to provide easy and quick connections  
Transformers up to 160 VA can be clipped to rail using accessory or directly fixed using screws through the easily accessible fixing points  
Multiple fixing possibilities :  
- clip to DIN rail using Cat. No. 0044 16 or 0428 99 ( $\leq 160$  VA)  
- direct panel mount  
Recommended protection :  
• for 40 and 63 VA : Type T fuses (5x20) time delay fuse to IEC 60127  
• for >100 VA use MCB Type C

Pack	Cat. Nos.	Single phase	
<b>Safety isolating transformers</b>			
<b>Primary : 230-400 V</b>			
<b>Secondary : 12-24 V</b>			
		Power in VA according to IEC/EN	Admissible instantaneous power at $\cos \varphi 0.5$
1	0428 40	40 VA	55
1	0428 41	63 VA	91
1	0428 42	100 VA	140
1	0428 43	160 VA	205
1	0428 44	220 VA	290
1	0428 45	310 VA	345
1	0428 47	630 VA	1 520
<b>Primary : 230-400 V</b>			
<b>Secondary : 24 V</b>			
		Power in VA according to IEC/EN	Admissible instantaneous power at $\cos \varphi 0.5$
1	0428 55	40 VA	55
1	0428 56	63 VA	91
1	0428 57	100 VA	140
1	0428 58	160 VA	205
1	0428 59	220 VA	290
1	0428 60	310 VA	345
1	0428 61	450 VA	1 100
1	0428 62	630 VA	1 520
<b>Safety isolating transformers</b>			
<b>Primary : 230-400 V</b>			
<b>Secondary : 24-48 V</b>			
		Power in VA according to IEC/EN	Admissible instantaneous power at $\cos \varphi 0.5$
1	0428 70	40 VA	55
1	0428 71	63 VA	80
1	0428 72	100 VA	150
1	0428 73	160 VA	160
1	0428 74	220 VA	290
1	0428 75	310 VA	345
1	0428 77	630 VA	1 520

Pack	Cat. Nos.	Single phase	
<b>Isolating transformers</b>			
<b>Primary : 230-400 V</b>			
<b>Secondary : 115 V</b>			
<b>With centre tap</b>			
		Power in VA according to IEC/EN	Admissible instantaneous power at $\cos \varphi 0.5$
1	6423 62	63 VA	91
1	6423 63	100 VA	140
1	6423 64	160 VA	205
1	6423 65	220 VA	290
1	6423 66	310 VA	345
1	6423 68	630 VA	1 520
<b>Isolating transformers</b>			
<b>Primary : 230-400 V</b>			
<b>Secondary : 115-230 V</b>			
		Power in VA according to IEC/EN	Admissible instantaneous power at $\cos \varphi 0.5$
1	0427 85	40 VA	55
1	0427 86	63 VA	91
1	0427 87	100 VA	140
1	0427 88	160 VA	205
1	0427 89	220 VA	290
1	0427 90	310 VA	345
1	0427 92	630 VA	1 520
<b>Accessories</b>			
<b>Clips for fixing up to 160 VA on to rail EN 60715</b>			
10	0044 16	Claw width 10 mm Threaded hole for M4 screws (Use two clips per transformer)	
<b>Mounting bracket</b>			
5	0428 99	DIN rail mounting bracket	

# compact transformers

## open type single phase (continued)

### Technical information

Conform to IEC / EN 61558-2-4 for 48 V, 115 V and 230 V and IEC / EN 61558-2-6 for 12 V and 24 V secondary

Products suitable for building into equipment conforming to EN 61131-2, EN 60204-1 and EN 61439 standards

IP 2X or IP XXB up to 250 VA - IK 04

Single phase 50-60 Hz - Class I

Insulation voltage : Primary/Secondary 4 470 V

Primary/Earth 2 240 V

Secondary/Earth (12 - 24 V) = 250 V ; 48, 115 and 230 V = 1780 V

Max. ambient operating temperature : 35 °C without derating

Protected against accidental contact with live parts up to 220 VA

### Dimensions

Fig. 1 - 40 to 220 VA

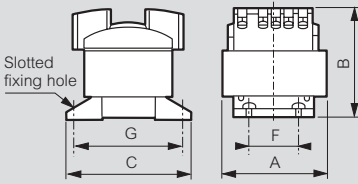

Fig. 2 - 310 VA<sup>1</sup>

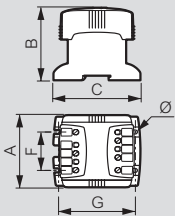
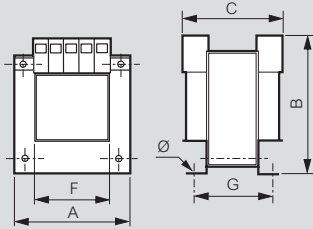

Fig. 3 - 450 to 630 VA



1 : Subject to secondary voltage (see tables)

Primary : 230 - 400 V  
Secondary : 12 - 0 - 12 V  
0 - 12 - 24 V

Cat. Nos.  
0428 40 to 0428 47

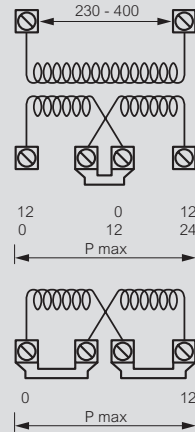

Primary : 230 - 400 V  
Secondary : 24 - 0 - 24 V  
0 - 24 - 48 V

Cat. Nos.  
0428 70 to 0428 77

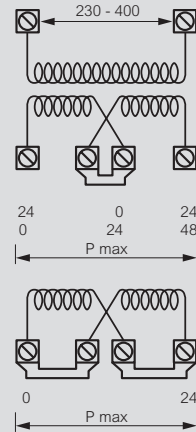

Primary : 230 - 400 V  
Secondary : 115 - 0 - 115 V  
0 - 115 - 230 V

Cat. Nos.  
0427 85 to 0427 92

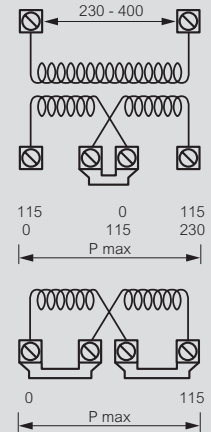

### Electrical characteristics

Cat. Nos.	Power (VA)	Dimensions (mm)			Fixing (mm)			Weight (kg)	No-load loss (W)	Total losses @ 100% load (W)	Voltage drop as % with		Efficiency with		Ucc %	Primary connection cable mm <sup>2</sup>			Secondary connection cable mm <sup>2</sup>			Fig.
		A	B	C	F	G	Ø				cos φ 1	cos φ 0.45	cos φ 1	cos φ 0.45		flexible	rigid	Ø mm	flexible	rigid	Ø mm	
<b>Primary 230-400 V - 24 V or 2 x 12 V secondary</b>																						
0428 40	40	84	70	98	40	86	4.5	0.9	3.7	13.1	18.3	12.7	0.75	0.6	15.6	1 to 4	1 to 4	4.5	1 to 4	1 to 4	4.5	1
0428 41	63	84	77	98	40	86	4.5	1.3	4.9	16.3	13.5	10.2	0.8	0.6	11.8	1 to 4	1 to 4	4.5	1 to 4	1 to 4	4.5	1
0428 42	100	84	86	98	40	86	4.5	1.6	6.2	21.0	10.5	8.7	0.8	0.7	9.5	1 to 4	1 to 4	4.5	1 to 4	1 to 4	4.5	1
0428 43	160	84	104	98	40	86	4.5	2.4	9.1	31.8	8.8	7.4	0.8	0.7	7.9	1 to 4	1 to 4	4.5	1 to 4	1 to 4	4.5	1
0428 44	220	96	115	110	40	98	4.5	3.4	12.6	40.0	6.9	6.3	0.85	0.7	6.5	1 to 4	1 to 4	4.5	1 to 4	1 to 4	4.5	1
0428 45	310	106	123	115	50	100	5.2	3.8	14.2	54.9	7.3	6.2	0.85	0.7	8.2	1 to 4	1 to 4	4.5	1 to 4	1 to 4	4.5	2
0428 47	630	126	126	141	90	105	6.5	8.0	25.5	62.4	4.3	2.6	0.91	0.82	3.5	1 to 4	1 to 4	4.5	1 to 16	1 to 25	6.5	3
<b>Primary 230-400 V - 24 V secondary</b>																						
0428 55	40	84	70	98	40	86	4.5	0.9	3.7	13.1	18.3	12.7	0.75	0.58	15.6	1 to 4	1 to 4	4.5	1 to 4	1 to 4	4.5	1
0428 56	63	84	77	98	40	86	4.5	1.3	4.9	16.3	13.5	10.2	0.79	0.64	11.8	1 to 4	1 to 4	4.5	1 to 4	1 to 4	4.5	1
0428 57	100	84	86	98	40	86	4.5	1.6	6.2	21.0	10.5	8.7	0.83	0.68	9.5	1 to 4	1 to 4	4.5	1 to 4	1 to 4	4.5	1
0428 58	160	84	104	98	40	86	4.5	2.4	9.1	31.8	8.8	7.4	0.83	0.69	7.9	1 to 4	1 to 4	4.5	1 to 4	1 to 4	4.5	1
0428 59	220	96	115	110	40	98	4.5	3.4	12.6	40.0	6.9	6.3	0.85	0.71	6.5	1 to 4	1 to 4	4.5	1 to 4	1 to 4	4.5	1
0428 60	310	106	123	115	50	100	5.2	3.82	14.2	54.9	7.3	6.2	0.85	0.72	8.2	1 to 4	1 to 4	4.5	1 to 4	1 to 4	4.5	2
0428 61	450	126	126	126	90	94	6.5	6.0	21.8	63.9	6.0	3.2	0.88	0.76	4.9	1 to 4	1 to 4	4.5	1 to 16	1 to 25	6.5	3
0428 62	630	126	126	141	90	105	6.5	8.0	25.5	62.4	4.3	2.6	0.91	0.82	3.5	1 to 4	1 to 4	4.5	1 to 16	1 to 25	6.5	3
<b>Primary 230-400 V - 48 V or 2 x 24 V secondary</b>																						
0428 70	40	84	77	98	40	86	4.5	1.3	3.7	12.9	18.0	12.5	0.8	0.6	15.4	1 to 4	1 to 4	4.5	1 to 4	1 to 4	4.5	1
0428 71	63	84	86	98	40	86	4.5	1.6	4.9	16.5	13.7	10.3	0.8	0.6	11.9	1 to 4	1 to 4	4.5	1 to 4	1 to 4	4.5	1
0428 72	100	84	104	98	40	86	4.5	2.4	6.2	21.0	10.4	8.7	0.8	0.7	9.4	1 to 4	1 to 4	4.5	1 to 4	1 to 4	4.5	1
0428 73	160	84	104	98	40	86	4.5	2.4	9.1	31.6	8.7	7.3	0.8	0.7	7.8	1 to 4	1 to 4	4.5	1 to 4	1 to 4	4.5	1
0428 74	220	96	115	110	40	98	4.5	3.4	12.6	39.5	6.7	6.2	0.85	0.7	6.3	1 to 4	1 to 4	4.5	1 to 4	1 to 4	4.5	1
0428 75	310	106	123	115	50	100	5.2	3.8	14.2	54.9	7.3	6.2	0.85	0.7	8.2	1 to 4	1 to 4	4.5	1 to 4	1 to 4	4.5	2
0428 77	630	126	126	141	90	105	6.5	8.0	25.5	63.3	4.2	2.6	0.9	0.8	3.5	1 to 4	1 to 4	4.5	1 to 16	1 to 25	6.5	3
<b>Primary 230-400 V - 115-230 V secondary</b>																						
0427 85	40	84	70	98	40	86	4.5	1.0	3.7	10.9	18.5	12.7	0.75	0.58	15.7	1 to 4	1 to 4	4.5	1 to 4	1 to 4	4.5	1
0427 86	63	84	77	98	40	86	4.5	1.3	4.9	15.6	12.5	9.7	0.80	0.65	11.0	1 to 4	1 to 4	4.5	1 to 4	1 to 4	4.5	1
0427 87	100	84	86	98	40	86	4.5	1.6	6.2	21.1	10.7	8.9	0.83	0.68	9.7	1 to 4	1 to 4	4.5	1 to 4	1 to 4	4.5	1
0427 88	160	84	104	98	40	88	4.5	2.4	9.1	32.3	8.8	7.3	0.83	0.69	7.9	1 to 4	1 to 4	4.5	1 to 4	1 to 4	4.5	1
0427 89	220	96	115	110	40	98	4.5	3.4	12.6	40.1	6.8	6.2	0.85	0.71	6.4	1 to 4	1 to 4	4.5	1 to 4	1 to 4	4.5	1
0427 90	310	106	123	115	50	100	5.2	3.8	14.2	54.0	7.3	6.2	0.85	0.7	8.2	1 to 4	1 to 4	4.5	1 to 4	1 to 4	4.5	2
0427 92	630	126	126	123	90	105	6.5	7.8	25.5	64.6	4.3	2.6	0.91	0.81	3.5	1 to 4	1 to 4	4.5	1 to 4	1 to 4	4.5	3

# how to calculate

## the rated power of a transformer

**In equipment containing control devices, the transformer power depends on the maximum power required at a given moment (inrush power), the permanent power, the voltage drop and power factor**

When determining the permissible instantaneous power (inrush power) required, the following factors should always be taken into account :

- two inrush currents cannot occur at the same time
- power factor  $\cos \varphi$  equals 0.5
- at maximum, 80% of devices are supplied at the same time (this percentage can be calculated precisely for each device)

### Determination of the inrush power

Where a simplified calculation of the power is required, the following formula can be used :

$$P_{\text{inrush}} = 0.8 (\Sigma P_m + \Sigma P_v + P_a)$$

$\Sigma P_m$  : sum of all contactor steady state power levels (holding power)

$\Sigma P_v$  : sum of all power levels of indicators and LEDs<sup>1</sup>

$P_a$  : inrush power of the largest contactor

#### Example :

A machine tool control cabinet comprising :

- 10 contactors for 4 kW motors, with a steady state power of 8 VA
- 2 contactors for 18.5 kW motor, with a steady state power of 20 VA
- 1 contactor for 45 kW motor, with a steady state power of 20 VA, and an inrush power of 250 VA  $\cos \varphi$  0.5
- 20 remote control relays, with a steady state power of 4 VA
- 30 signalling LEDs, with a consumption of 1 VA each

$$-\Sigma P_m = 220 \text{ VA } \{ (10 \times 8 \text{ VA}) + (2 \times 20 \text{ VA}) + (1 \times 20 \text{ VA}) + (20 \times 4 \text{ VA}) \}$$

$$-\Sigma P_v = 30 \text{ VA } (30 \times 1 \text{ VA})$$

$$-P_a = 250 \text{ VA}$$

$$P_{\text{inrush}} = 0.8 (220 + 30 + 250) = 400 \text{ VA at } \cos \varphi \text{ 0.5}$$

### Determination of the rated power of a transformer

For control transformers, in particular, simply start with an inrush power at  $\cos \varphi$  0.5 and read the size from the table below

Rated power in VA IEC and CSA	Admissible instantaneous power in VA IEC/EN 61558-2-2 with $\cos \varphi$ of :								
	0.2	0.3	0.4	0.5	0.6	0.7	0.8	0.9	1
40	90	80	72	66	61	57	53	51	53
63	160	140	130	120	110	100	90	90	90
100	240	190	170	160	150	140	130	130	140
160	480	400	350	300	270	240	220	200	190
250	830	690	590	510	450	400	360	330	310
400	1 600	1 400	1 200	1 000	900	800	800	700	700
630	2 000	1 800	1 500	1 400	1 200	1 100	1 100	1 000	1 000
1 000	5 400	4 600	4 000	3 600	3 200	3 000	2 700	2 600	2 500
1 600	9 000	8 000	7 200	6 600	6 100	5 700	5 400	5 300	5 600
2 500	7 300	6 600	6 000	5 700	5 200	4 900	4 700	4 600	5 100
4 000	34 500	28 800	24 400	17 000	16 600	16 400	14 800	13 400	12 400

From the example above, an inrush of 460 VA at  $\cos \varphi$  0.5 gives a transformer size of 250 VA

### Checking the selection

As a precaution, make the following checks on each of your devices :

- first calculate the sum of the steady state power for the coils and the LEDs powered at the same time
- then apply a coefficient : use either our hypothetical figure of 80% of devices at steady state power, or the actual calculation for your equipment
- the power of the chosen transformer shall be greater than or equal to the result of the calculation

1 : LED = Light Emitting Diode

### General information

Transformers take around 25 times the load at switch on

$VA \div V =$  current in the winding  
either PRIMARY or SECONDARY

$$\text{i.e. } \frac{300 \text{ VA}}{12 \text{ V}} = 25 \text{ A} \times 25 = 625 \text{ A}$$

#### The power triangle :

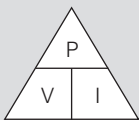

### Secondary power/voltage information

Example : compact transformer 100 VA - 12/24 V Cat. No. 0428 42

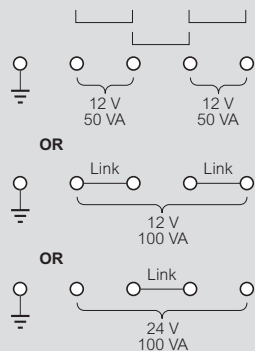

### Identification of markings

#### • Changing voltage



Isolation transformer (functional insulation between primary and secondary)



Auto transformer (no insulation between primary and secondary)

#### • Control circuit power supply



Control transformer (functional insulation between primary and secondary)

#### • Electric shock protection

- Protection against direct and indirect contact by :



Safety transformers (reinforced insulation between primary and secondary, no-load voltage < 50 V)

- Protection against indirect contact by :



Circuit separation transformers (reinforced insulation between primary and secondary)

The transformer function(s) can either be defined by the equipment designer or can be imposed by installation guidelines or the equipment standard

#### Definitions of electrical shock :

- Electric shocks : physiopathological effect resulting from an electrical current passing through the human body
- Direct contact : persons coming into contact with live parts (connected to the mains)
- Indirect contact : persons coming into contact with grounding which is accidentally live following an insulation fault



# protection of transformers, primary and secondary circuits

## Protection of transformers

In accordance with the IEC EN 61558 standard, transformers must be protected against overload and short-circuit conditions which may occur during normal operation

The standard does not specify the type or location of the protective device : it is the manufacturer's responsibility to choose the most suitable position, either on the primary or secondary side. The rating, type and location of the protective device are to be indicated on the device identification plate

## Protection of the primary and secondary circuits

### General

Circuits must be protected against overload and short-circuit conditions. Protection against overload is compulsory if the circuit is likely to be affected by an overload current. This protection can be installed at the supply source or end of the circuit  
Protection against a short-circuit is compulsory in all installations ; this protection has to be installed at the supply source of the circuit

### Supply circuits (transformer primary)

The transformer is a device which cannot itself generate overload. Its supply circuit therefore only requires protection against a short-circuit. When a transformer is energised, a very high inrush current (around 25 In)<sup>1</sup> is produced for approximately 10 ms  
When protecting the circuit, both factors must be considered

Legrand offers three possibilities :

- type aM cartridge fuses
- type D MCBs (with magnetic tripping set at 12 In average)
- type C MCBs (with magnetic tripping set at 7 In average)

### Example :

#### control transformer 630 VA - 230/24 V Cat. No. 0442 37 (see p. 34)

In primary 2.74 A (VA ÷ V)  
I inrush at power-up 68.5 A (25 x 2.74 A)

Protection against a short-circuit can be provided by :

- type aM 6 A cartridge fuse
- type D 6 A MCBs
- type C 13 A MCBs - (16 A nearest UK)

<sup>1</sup> : In = nominal rating of circuit

## Primary protection

### Minimum protection rating for primary supply of the transformer :

Power (VA)	230 V single phase			400 V single phase			400 V three phase		
	aM fuse	C MCB	D MCB	aM fuse	C MCB	D MCB	aM fuse	C MCB	D MCB
40	0.5	1		0.25	1				
50	1	1	1	0.5	1				
63	1	2	1	0.5	1				
100	1	3	1	1	2	1			
150	2	6	2	1	3	1			
160	2	6	2	1	3	1	1		
200	2	6	3	1	3	2			
250	2	6	3	1	6	2	1		
300	4	10	6	2	6	2			
400	4	10	6	2	6	2	2		
500	6	16	6	4	10	3			
630	6	16	6	4	10	3	2	6	2
750	8	16	10	6	10	6	2	6	3
1 000	10	20	10	6	16	6	4	10	3
1 250	10	25	16	6	20	10	4	10	6
1 500	10	32	16	10	20	10	4	16	6
1 600	10	32	16	10	20	10	6	16	6
2 000	12	40	16	10	25	10			
2 500	16	50	20	10	32	16	6	20	10
3 000	16	50	32	12	40	20			
3 500	20	50	32	16	40	20			
4 000	20	80	32	16	50	20	10	32	16
5 000	25	100	40	16	63	25	12	32	16

These values are given for information only for transformers with inrush currents of around 25 In.

## Protection of the secondary circuit

The secondary circuit must be protected against overload and short-circuit conditions. For overload, check that the protection rating chosen is lower than or equal to the transformer secondary current. For short-circuit, ensure that a short-circuit occurring at the furthest point of the circuit will trigger the protective device within 5 seconds  
Legrand offers two possibilities :

- type gG cartridge fuses
- type C MCBs (with magnetic tripping set at 7 In average)

If the transformer only supplies a single circuit, and provided the calculations show perfect compatibility, transformer protection (if on secondary) and circuit protection can be one and the same. A single protective device performs both functions (see table of transformer protective devices)

If the transformer supplies several circuits, overload and short-circuit calculations must be performed for each individual circuit. To check that the device chosen is suitable, an approximate minimum short-circuit value can be obtained using the following formula

### Formula for determining the secondary protection rating

Calculate the minimum short-circuit at the furthest point on the circuit :

$$I_{c/c \text{ min.}} = \frac{U_s}{\left(\frac{U_s^2}{P} \times \frac{U_{c/c \%}}{100}\right) + \frac{2\rho l}{S}}$$

U<sub>s</sub> = transformer secondary voltage

P = transformer power

U<sub>c/c %</sub> = transformer short-circuit voltage

l = line length in m

S = line cross section in mm<sup>2</sup>

ρ copper = 0.027 Ω mm<sup>2</sup>/m

Choose the protection rating so as to obtain a cut-off time of 5 seconds max. for a current I<sub>c/c</sub> defined above :

$$\text{type gG fuse : } I_n \leq \frac{I_{c/c \text{ min.}}}{4}$$

$$\text{type C MCB : } I_n \leq \frac{I_{c/c \text{ min.}}}{8}$$

### Example : control transformer 630 VA - 230/24 V Cat. No. 0442 37 (see p. 34)

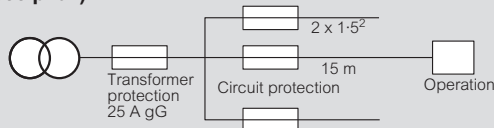

$$I_{c/c \text{ min.}} = \frac{24}{\left(\frac{24^2}{630} \times \frac{3.3}{100}\right) + \frac{2 \times 0.027 \times 15}{1.5}} = 44.42 \text{ A} = \text{Use either :}$$

$$\frac{44.42}{4} = 11.10 \rightarrow \text{gG fuse 10 A max.} \quad \frac{44.42}{8} = 5.55 \rightarrow \text{C type MCB 5 A max.}$$

## Secondary protection

### Ratings and types of protective devices to be used for single phase transformer protection according to VA rating and secondary voltage

Rated power (VA) IEC/CSA	24 V			48 V			110 V			230 V		
	Fuse A	Type	Curve C MCB	Fuse A	Type	Curve C MCB	Fuse A	Type	Curve C MCB	Fuse A	Type	Curve C MCB
40	2	T		1	T		400 m	T		200 m	T	
50	2	T	2	1	T	1	500 m	T	0.5	200 m	T	0.2
63	3-15	T		1.6	T		630 m	T		315 m	T	
100	4	gG	4	2	gG	2	1	gG	1	0.5	gG	0.5
150	6	gG	6	4	gG	4	2	gG	2	1	gG	1
160	8	gG	8	4	gG	4	2	gG	2	1	gG	1
200	8	gG	8	4	gG	4	2	gG	2	1	gG	1
250	10	gG	10	6	gG	6	2	gG	2	1	gG	1
300	12	gG	12	6	gG	6	4	gG	4	2	gG	2
400	16	gG	16	8	gG	8	4	gG	4	2	gG	2
500	20	gG	20	10	gG	10	6	gG	6	2	gG	2
630	25	gG	25	12	gG	12	6	gG	6	3	gG	3
750		gG		16	gG	16	8	gG	8	4	gG	4
1 000	40	gG	40	20	gG	20	8	gG	8	4	gG	4
1 250		gG			gG		12	gG	12		gG	
1 500		gG			gG		16	gG	13	8	gG	8
1 600	63	gG	63	32	gG	32	16	gG	13	8	gG	8
2 000		gG			gG		20	gG	20	8	gG	8
2 500	100	gG	100	50	gG	50	20	gG	20	10	gG	10
3 000		gG			gG		32	gG	32		gG	
3 500		gG			gG		32	gG	32		gG	
4 000		gG			gG		32	gG	32	16	gG	16
5 000		gG			gG		50	gG	50		gG	

# filtered power supplies

## open type single phase



Dimensions and technical information **opposite and p. 41**

Conform to IEC / EN 61558-2-6  
UL 60950 and CAN/CSA C22.2 N° 60 950.00  
Filtered power supplies for PLCs and other equipment requiring a voltage of 12 V DC or 24 V DC

Include :

- twin output terminals for ease of connection
- safety transformer with interference filtration
- fuse protection on output
- green LED output voltage indicator
- capacitor in filtered range

Supplied with a connection link for quick connection between - and  $\pm$  up to 15 A

Fixing options :

- clip directly to DIN rail up to 24 W
- clip on or screw fixing up to 120 W
- screw fixing only above 120 W

Pack	Cat. Nos.	Single phase filtered			
<b>12 V<sub>DC</sub> output</b>					
230-400 V $\pm$ 15 V <sub>AC</sub> (input) / 12 V <sub>DC</sub> (output)					
		Power (W)	Current rating (A)	Terminal capacity (mm <sup>2</sup> ) Flexible cable	
				Input	Output
1	0470 01	12	1	6	6
1	0470 02	30	2.5	6	6
1	0470 03	60	5	6	6
1	0470 04	120	10	6	6
<b>24 V<sub>DC</sub> output</b>					
230-400 V $\pm$ 15 V <sub>AC</sub> (input) / 24 V <sub>DC</sub> (output)					
		Power (W)	Current rating (A)	Terminal capacity (mm <sup>2</sup> ) Flexible cable	
				Input	Output
1	0470 20	12	0.5	6	6
1	0470 21	24	1	6	6
1	0470 22	60	2.5	6	6
1	0470 23	120	5	6	6
1	0470 24	240	10	6	6
1	0470 25	360	15	6	6

### Technical information



Conform to IEC / EN 61558-2-6, UL 60950  
CAN/CSA C22.2 N° 60 950.00

Products are compatible with EN 61131-2, EN 60204 and EN 61439 apparatus

Input voltage : 230/400 V<sub>AC</sub>  $\pm$  15 V single phase 50/60 Hz - Class I

Output voltage : 12 V<sub>DC</sub> or 24 V<sub>DC</sub>

Insulation voltage : Input/Output 4 510 V

Input/Earth 2 260 V

Output/Earth 500 V

Max. ambient temperature without derating : 60 °C

Ripple factor : <3 %

Cooling by natural convection

Integral fuse protection on output

Can be fixed to symmetrical rail  $\pm$  7.5 mm or 15 mm depth EN 60715

Screw fix only Cat. Nos. 0470 04/24 and 25

Screw fix or clip on to DIN rail Cat. Nos. 0470 02/03/22 and 23

Supplied with a connection link for quick connection between terminals and earth

**Note :** To conform to UL, product must be mounted in the vertical position (mounting against support) for Class A ambient temperature rating 25 °C

### Dimensions

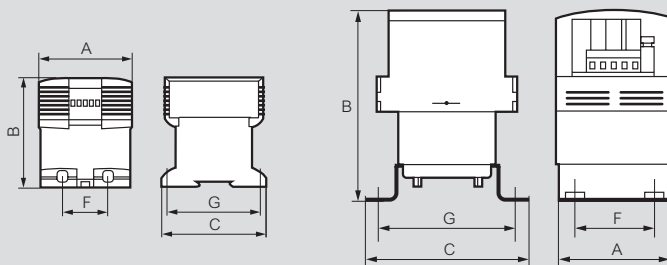

Cat. Nos. 0470 01/02/03  
and 0470 20/21/22/23

Cat. Nos. 0470 04/24/25

Cat. Nos.	A (mm) Width	B (mm) Depth	C (mm) Height	F x G (mm) Fixing ctrs	Ø (mm)	Weight (Kg)
0470 01	68	98	88	DIN	-	1.00
0470 02	93	121	105	DIN	4-6	2.45
0470 03	105	135	115	DIN	4-6	3.60
0470 04	126	186	175	75 x 150	5-5	6.35
0470 20	68	98	88	DIN	-	1.00
0470 21	68	98	88	DIN	-	1.00
0470 22	93	121	105	DIN	4-6	2.45
0470 23	105	135	115	DIN	4-6	3.60
0470 24	126	186	175	75 x 150	5-5	6.40
0470 25	126	206	175	75 x 150	5-5	7.60

### Operating diagram

Operating current up to 15 A

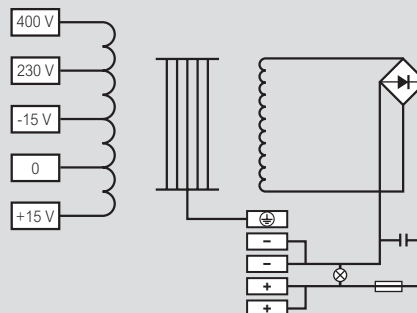

# filtered power supplies

## open type single phase (continued)

### Circuit protection (double pole MCB)

Single phase		Input 230/400 V ±15 V				
I	U	Protection	12 V		24 V	
			Internal	External	Internal	External
0.5 A	Power supply		0470 20			
		MCB/Fuse			T 0.5 A L <sup>1</sup>	4091 95 (1 A)
	MCB/Fuse			PTC	4091 95 (1 A)	
1 A	Power supply	0470 01		0470 21		
	MCB/Fuse	T 1 A L <sup>1</sup>	4091 95 (1 A)	T 1 A L <sup>1</sup>	4091 95 (1 A)	
2.5 A	Power supply	0470 02		0470 22		
	MCB/Fuse	T 2.5 A L <sup>1</sup>	4091 97 (3 A)	T 2.5 A L <sup>1</sup>	4091 97 (3 A)	
5 A	Power supply	0470 03		0470 23		
	MCB/Fuse	T 5 A L <sup>1</sup>	4091 99 (6 A)	T 5 A L <sup>1</sup>	4091 99 (16 A)	
10 A	Power supply	0470 04		0470 24		
	MCB/Fuse	T 10 A L <sup>1</sup>	4092 00 (10 A)	T 10 A L <sup>1</sup>	4092 00 (10 A)	
15 A	Power supply			0470 25		
	MCB/Fuse				4092 02 (16 A)	

1 : T type fuse is a time delay fuse (5 x 20 mm)

### Primary fuse protection required for UL conformity

Supply 230 V : Use 250 V time delay HRC fuse  
UL Category Code JDYX2

Supply 400 V : Use 500 V time delay HRC fuse  
UL Category Code JDYX

Secondary voltage	12 V		24 V	
Primary voltage	230 V ~	400 V ~	230 V ~	400 V ~
Power supply			0470 20	
Fuse rating			0.315 A T	2/10 A
Power supply	0470 01		0470 21	
Fuse rating	0.315 A	2/10 A	0.4 A	2/10 A
Power supply	0470 02		0470 22	
Fuse rating	0.8 A	4/10 A	1 A	6/10 A
Power supply	0470 03		0470 23	
Fuse rating	1.6 A	8/10 A	2 A	1 A
Power supply	0470 04		0470 24	
Fuse rating	3.15 A	1 <sup>1/2</sup> A	4 A	2 <sup>1/4</sup> A
Power supply			0470 25	
Fuse rating			6.3 A	3 A

### Electrical characteristics

Cat. Nos.	Voltage (V)	Current rating (A)	Weight (Kg)	Input under load 230 V (A)	Input under load 400 V (A)	Operating voltage				No-load loss (W)	Total loss at nominal load 100 % (W)	Voltage drop (%)
						No-load (V)	Underload (V)	With 100 mA load and input voltage +10%	With nominal load input voltage -15%			
<b>Output 12 V</b>												
0470 01	12	1	1	0.12	0.06	14.4	11.7	15.5	10.3	4.4	7.3	23.5
0470 02	12	2.5	2.45	0.33	0.19	13.9	11.6	15.2	10.2	8.3	11.9	19.4
0470 03	12	5	3.6	0.60	0.34	14.1	12.1	15.5	10.5	11.4	17.1	17.2
0470 04	12	10	6.35	1.24	0.72	14.7	11.8	16.1	10.4	20.2	33.7	24.7
<b>Output 24 V</b>												
0470 20	24	0.5	1	0.12	0.06	27.6	22.9	29.4	20.1	4.4	7.3	20.66
0470 21	24	1	1	0.18	0.10	29.0	22.8	31.2	20.2	4.4	10.3	27.03
0470 22	24	2.5	2.45	0.47	0.27	27.8	23.3	30.4	20.4	8.3	16.3	19.46
0470 23	24	5	3.6	0.88	0.51	27.5	23.2	30.2	20.3	11.4	25.4	18.68
0470 24	24	10	6.35	1.88	1.09	27.7	23.5	30.5	20.5	20	45.3	18.20
0470 25	24	15	7.6	2.53	1.46	27.5	23.2	30.2	20.2	23	54.7	18.70

# CX<sup>3</sup> power contactors without handle

16 A to 63 A

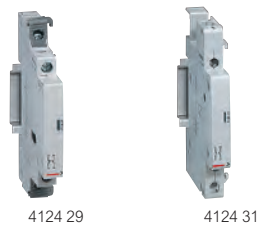

Technical information p. 44  
Dimensions p. 47

Conform to IEC/EN 61095  
Space for power supply busbar on top (up to 25 A)

Pack	Cat. Nos.	Power contactors with 24 V~ coil		
		<b>Double pole - 250 V~</b>		
1	4125 03	I max 16 A		Type of contact N/C + N/O Number of modules 1
1	4125 05	25 A		2 N/O 1
		<b>Power contactors with 230 V~ coil</b>		
		<b>Double pole - 250 V~</b>		
4	4125 21	I max 16 A		Type of contact N/C + N/O Number of modules 1
1	4125 24	25 A		2 N/C 1
		<b>Four pole - 400 V~</b>		
5	4125 35	25 A		4 N/O 2
1	4125 36	25 A		4 N/C 2
1	4125 33	25 A		2 N/C + 2 N/O 2

Pack	Cat. Nos.	Signalling auxiliaries for CX <sup>3</sup> contactors			
		Auxiliary changeover switch Used to signal the position status of the contacts on the product to which it is connected			
		<b>For 1 module contactors 16 A to 25 A</b> Maximum 2 auxiliary devices per contactor Fitted on left-hand side of contactor			
1	4124 29	I max 5 A	Voltage 250 V~	Contact N/C + N/O	Number of modules 0-5
		<b>For 2 module contactors 25 A</b> Maximum 2 auxiliary devices per contactor Fitted on left-hand side of contactor			
1	4124 30	5 A	250 V~	N/C + N/O	0-5
		<b>For 63 A contactors</b> Maximum 1 auxiliary device per contactor Fitted on left-hand side of contactor			
1	4124 31	5 A	250 V~	N/C + N/O	0-5
		<b>Accessory</b>			
10	4063 07	Spacing unit 0.5 module To be placed between every 2 contactors to aid cooling			



# CX<sup>3</sup> power contactors with handle

16 A to 63 A



4125 44



4125 56



4124 29



4124 31

Technical information p. 44  
Dimensions p. 47

Conform to IEC/EN 61095  
Space for power supply busbar on top (up to 25 A)

Pack	Cat. Nos.	<b>Power contactors with 230 V~ coil and handle</b>			
		Manual override for test and repair function, carried out via the handle Permanent "ON" or "OFF" without automatic reset			
		<b>Double pole - 250 V~</b>			
4	4125 44	I max	Connection	Type of contact	Number of modules
1	4125 45 <sup>1</sup>	25 A		2 N/O	1
1	4125 47 <sup>1</sup>	40 A		2 N/O	2
1	4125 47 <sup>1</sup>	63 A		2 N/O	2
		<b>Triple pole 400 V~</b>			
1	4125 49 <sup>1</sup>	40 A		3 N/O	3
1	4125 50 <sup>1</sup>	63 A		3 N/O	3
		<b>Four pole 400 V~</b>			
1	4125 53 <sup>1</sup>	40 A		4 N/O	3
1	4125 56 <sup>1</sup>	63 A		4 N/O	3

Pack	Cat. Nos.	<b>Signalling auxiliaries for CX<sup>3</sup> contactors</b>			
		Auxiliary changeover switch Used to signal the position status of the contacts on the product to which it is connected			
		<b>For 1 module contactors 16 A to 25 A</b> Maximum 2 auxiliary devices per contactor Fitted on left-hand side of contactor			
1	4124 29	I max	Voltage	Contact	Number of modules
		5 A	250 V~	N/C + N/O	0-5
		<b>For 2 module contactors 25 A</b> Maximum 2 auxiliary devices per contactor Fitted on left-hand side of contactor			
1	4124 30	5 A	250 V~	N/C + N/O	0-5
		<b>For 40 and 63 A contactors</b> Maximum 1 auxiliary device per contactor Fitted on left-hand side of contactor			
1	4124 31	5 A	250 V~	N/C + N/O	0-5
		<b>Accessory</b>			
10	4063 07	Spacing unit 0.5 module To be placed between every 2 contactors to aid cooling			



1 : Handle can be accessed after removing blanking plate

## Technical information

- Rated impulse withstand voltage (Uimp) : 4 kV
- Mechanical endurance (no. of operating cycles) : 10<sup>6</sup> cycles
- Operating temperatures : - 25 °C to + 40 °C
- Storage temperatures : - 40 °C to + 70 °C

### Contact protection against short circuits according to standard EN 61095, conditional short circuit current:

- I<sub>q</sub> = 6 kA for 16 to 25 A contactors
- I<sub>q</sub> = 3 kA for 40 to 63 A contactors

Circuit breaker or gG fuse rated:

- ≤ 16 A for 16 A rating      • ≤ 40 A for 40 A rating
- ≤ 25 A for 25 A rating      • ≤ 63 A for 63 A rating

### Consumption of a contactor control coil

16 A and 25 A power contactors					
Coil voltage	24 V~		230 V~ low noise	230 V~	
Current	16 A and 25 A	25 A	25 A	16 A and 25 A	16 A and 25 A
Type of contact	NC + NO 2 NO	4 NO	2 NO	NC + NO 2 NO 2 NC	2 NC + 2 NO 4 NO 4 NC
Dimensions	1 mod.	2 mod.	1 mod.	1 mod.	2 mod.
Holding current	200 mA	300 mA	12 mA	20 mA	20 mA
Inrush current	970 mA	2500 mA	60 mA	90 mA	200 mA

40 A and 63 A power contactors				
Coil voltage	24 V~		230 V~	
Current	40 A and 63 A	40 A and 63 A	40 A and 63 A	40 A and 63 A
Type of contact	2 NO	4 NO	2 NO 2 NC	3 NO 4 NO 4 NC
Dimensions	2 mod.	3 mod.	2 mod.	3 mod.
Holding current	250 mA	270 mA	15 mA	30 mA
Inrush current	1750 mA	1500 mA	150 mA	200 mA

### Recommendations

Insert a spacing module (Cat. No. 4063 07 p. 42-43):  
 - every two contactors when the ambient temperature is below 40 °C  
 - every contactor when the ambient temperature is between 40 and 60 °C

Contact rating	40 °C	50 °C	60 °C
I <sub>e</sub> = 16 A	16 A	14 A	12 A
I <sub>e</sub> = 25 A	25 A	22 A	20 A
I <sub>e</sub> = 40 A	40 A	36 A	32 A
I <sub>e</sub> = 63 A	63 A	57 A	50 A

### Max. connection cross section in mm<sup>2</sup>

Conductor type	Ratings ≤ 25 A	Ratings 40 & 63 A
Rigid	6 <sup>2</sup> or 2 x 2.5 <sup>2</sup>	25 <sup>2</sup> or 2 x 10 <sup>2</sup>
Flexible	6 <sup>2</sup> or 2 x 2.5 <sup>2</sup>	25 <sup>2</sup> or 2 x 10 <sup>2</sup>
Flexible with single end cap	6 <sup>2</sup>	16 <sup>2</sup>
Flexible with double end cap	2 x 4 <sup>2</sup>	2 x 16 <sup>2</sup>

## Contactor selection charts

### Incandescent lamps

Tungsten and halogen filaments 230 V~								
Nominal wattage	40 W	60 W	75 W	100 W	150 W	200 W	500 W	1000 W
16 A	45	30	24	19	13	10	4	2
25 A	60	48	38	30	20	15	6	3
40 A	96	77	61	48	32	24	10	5
63 A	154	123	97	77	51	38	15	8

Nominal wattage	ELV halogen bulbs with ferromagnetic ballast						ELV halogen bulbs with electronic ballast					
	20 W	35 W	50 W	75 W	100 W	150 W	20 W	35 W	50 W	75 W	100 W	150 W
16 A	32	20	15	12	9	6	60	40	28	18	14	9
25 A	52	30	24	16	12	8	80	50	40	26	20	13
40 A	68	39	31	21	16	10	112	70	56	36	28	18
63 A	88	51	41	27	20	14	157	98	78	51	39	25

## Contactor selection charts (continued)

### Fluorescent tubes with ferromagnetic ballast

Nominal wattage	Single parallel compensated fluorescent					Double series compensated fluorescent				
	18 W	20 W	36 W	58 W	115 W	2 x 20 W	2 x 36 W	2 x 40 W	2 x 58 W	2 x 140 W
16 A	24	24	16	11	5	30	24	22	15	6
25 A	33	30	25	17	9	45	38	35	24	10
40 A	43	39	33	22	12	68	57	53	36	15
63 A	56	51	42	29	15	101	86	79	54	23

Nominal wattage	Quadruple series compensated fluorescent				Compact fluorescent with built-in starter			
	4 x 18 W				7 W	10 W	18 W	26 W
16 A	16				50	40	28	19
25 A	24				60	50	42	28
40 A	36				78	65	55	36
63 A	54				101	85	71	47

### Fluorescent tubes with electronic ballast

Nominal wattage	Single fluorescent				Double fluorescent		
	18 W	30 W	36 W	58 W	2 x 18 W	2 x 36 W	2 x 58 W
16 A	72	42	36	22	36	20	12
25 A	110	68	58	36	56	30	19
40 A	165	102	87	54	84	45	29
63 A	248	153	131	81	126	68	43

Nominal wattage	Triple fluorescent (series compensated)			Quadruple fluorescent (series compensated)	
	3 x 14 W	3 x 18 W	4 x 14 W	4 x 18 W	
16 A	34	26	26	20	
25 A	46	38	37	28	
40 A	62	51	52	39	
63 A	84	69	73	55	

Nominal wattage	Compact fluorescent with built-in electronic power supply				
	7 W	11 W	15 W	20 W	23 W
16 A	120	80	64	50	43
25 A	200	125	90	70	60
40 A	280	175	126	98	84
63 A	392	245	176	137	118

### Discharge lamps with compensation

Nominal wattage	Metal halogenide						Low pressure sodium vapour					
	35 W	70 W	100 W	150 W	250 W	400 W	18 W	35 W	55 W	90 W	135 W	180 W
16 A	10	6	5	3	2	1	12	6	5	3	2	2
25 A	15	9	7	5	3	2	20	10	7	5	3	3
40 A	23	14	11	8	5	3	30	15	11	8	5	5
63 A	34	20	16	11	7	5	45	23	16	11	7	7

Nominal wattage	High pressure sodium vapour					High pressure mercury vapour				
	70 W	150 W	250 W	400 W	1000 W	50 W	80 W	125 W	250 W	400 W
16 A	8	7	5	3	1	11	8	6	3	2
25 A	10	9	6	4	2	15	10	8	4	3
40 A	15	14	9	6	3	21	14	11	6	4
63 A	23	20	14	9	5	29	20	16	8	6

Nominal wattage	High pressure mixed			
	100 W	160 W	250 W	400 W
16 A	9	6	4	2
25 A	11	7	5	3
40 A	14	9	7	4
63 A	19	12	8	5

# CX<sup>3</sup> push-buttons, control switches and LED indicators **N**



Dimensions p. 47

Pack	Cat. Nos.	Push buttons and control switches	Connection	Number of modules
10	4129 08	1 NO Conform to IEC 60669-1 Nominal rating 20 A - 250 V $\sim$ Compatible with fluorescent lamps (20 AX) Accept prong-type supply busbars		1
10	4129 09	1 NC		1
10	4129 16	<b>Dual functions push buttons without indicator</b> 1 NO (green push button) + 1 NC (red push-button)		1
10	4129 10	<b>Single function control switches</b> 2 NO		1
10	4129 11	1 NO + NC		1
10	4129 12	<b>Dual functions control switches with indicator</b> 1 NO + green LED indicator 12/48 V $\sim$ / $\equiv$		1
10	4129 13	1 NC + red LED indicator 12/48 V $\sim$ / $\equiv$		1
10	4129 14	1 NO + green LED indicator 110/400 V $\sim$		1
10	4129 15	1 NC + red LED indicator 110/400 V $\sim$		1

Pack	Cat. Nos.	LED indicators	Connection	Number of modules
		Equipped with non replaceable LED lamps LED life: 100 000 h LED consumption: 0.17 W under 230 V $\sim$ / 0.11 W under 24 V $\sim$ Conform to IEC 60947-5-1 Accept prong-type supply busbars		
		<b>Single - 12/48 V<math>\sim</math>/<math>\equiv</math></b>		
10	4129 21	● Green		1
10	4129 22	● Red		1
10	4129 23	● Yellow		1
10	4129 24	● Blue		1
10	4129 25	○ White		1
		<b>Single - 110/400 V<math>\sim</math></b>		
10	4129 26	● Green		1
10	4129 27	● Red		1
10	4129 28	● Yellow		1
10	4129 29	● Blue		1
10	4129 30	○ White		1
10	4129 31	<b>Double - 110/400 V<math>\sim</math></b> ● ● Green/Red		1
		<b>Triple - 230/400 V<math>\sim</math></b>		
10	4129 32	○ ○ ○ White		1
10	4129 33	● ● ● Red		1
10	4129 34	● ● ● Red/Yellow/Green		1
10	4129 35	● ● ● Red/Yellow/Blue		1
		<b>TX<sup>3</sup> LED indicators - 230 V<math>\sim</math></b>		
		Equipped with non replaceable LED lamps		
		<b>Single</b>		
12	6040 77	● Green		1
12	6040 78	● Red		1
12	6040 79	● Orange		1

Changeover switches p. 31





4130 91



4130 98

Technical information and dimensions **opposite and p. 47**

In the event of an overload, switch off the power supply and allow the transformer to cool down before switching on again  
Wall or rail mounted

Pack	Cat. Nos.	Bell transformers																								
1	4130 90	<p> Conform to IEC/EN 61558-2-8 Supplied with label holder Protected against overloads and short circuits Power to 8 V-12 V or 24 V access control devices such as bells and chimes Possibility for supply busbars to run through (Cat. Nos. 4130 90/91)</p> <p><b>230 V / 8 V</b></p> <table border="1"> <thead> <tr> <th>Secondary (V)</th> <th>Rating (A)</th> <th>Power (VA)</th> <th>Number of 17.5 mm modules</th> </tr> </thead> <tbody> <tr> <td>8 V~</td> <td>0.5 A</td> <td>4 VA</td> <td>2</td> </tr> </tbody> </table> <p><b>230 V / 12 V - 8 V</b></p> <table border="1"> <thead> <tr> <th>Secondary (V)</th> <th>Rating (A)</th> <th>Power (VA)</th> <th>Number of 17.5 mm modules</th> </tr> </thead> <tbody> <tr> <td>12/8 V~</td> <td>0.66/1 A</td> <td>8 VA</td> <td>2</td> </tr> </tbody> </table> <p><b>230 V / 24 V - 12 V</b></p> <table border="1"> <thead> <tr> <th>Secondary (V)</th> <th>Rating (A)</th> <th>Power (VA)</th> <th>Number of 17.5 mm modules</th> </tr> </thead> <tbody> <tr> <td>24/12 V~</td> <td>1/1.5 A</td> <td>24/18 VA</td> <td>4</td> </tr> </tbody> </table>	Secondary (V)	Rating (A)	Power (VA)	Number of 17.5 mm modules	8 V~	0.5 A	4 VA	2	Secondary (V)	Rating (A)	Power (VA)	Number of 17.5 mm modules	12/8 V~	0.66/1 A	8 VA	2	Secondary (V)	Rating (A)	Power (VA)	Number of 17.5 mm modules	24/12 V~	1/1.5 A	24/18 VA	4
Secondary (V)	Rating (A)	Power (VA)	Number of 17.5 mm modules																							
8 V~	0.5 A	4 VA	2																							
Secondary (V)	Rating (A)	Power (VA)	Number of 17.5 mm modules																							
12/8 V~	0.66/1 A	8 VA	2																							
Secondary (V)	Rating (A)	Power (VA)	Number of 17.5 mm modules																							
24/12 V~	1/1.5 A	24/18 VA	4																							
1	4130 91																									
1	4130 93																									

Pack	Cat. Nos.	Safety transformers																																			
1	4130 95	<p> Conform to IEC/EN 61558-2-6 Supplied with label holder Protected against overloads and short circuits Power to 12 V or 24 V devices such as modular power contactors, latching relays and signalling units</p> <p><b>230 V / 12 or 24 V</b></p> <table border="1"> <thead> <tr> <th>P (VA)</th> <th>No-load loss (W)</th> <th>Voltage % drop Cos φ = 1</th> <th>Efficiency % Cos φ = 1</th> <th>U<sub>CC</sub> (%)</th> <th>I (A) primary loaded</th> <th>Number of 17.5 mm modules</th> </tr> </thead> <tbody> <tr> <td>16</td> <td>2.5</td> <td>34.6</td> <td>60</td> <td>27.5</td> <td>0.10</td> <td>4</td> </tr> <tr> <td>25</td> <td>2.5</td> <td>29</td> <td>66</td> <td>23.3</td> <td>0.14</td> <td>4</td> </tr> <tr> <td>40</td> <td>4</td> <td>17.9</td> <td>68</td> <td>14.4</td> <td>0.22</td> <td>5</td> </tr> <tr> <td>63</td> <td>4</td> <td>15.7</td> <td>75</td> <td>13.6</td> <td>0.33</td> <td>5</td> </tr> </tbody> </table>	P (VA)	No-load loss (W)	Voltage % drop Cos φ = 1	Efficiency % Cos φ = 1	U <sub>CC</sub> (%)	I (A) primary loaded	Number of 17.5 mm modules	16	2.5	34.6	60	27.5	0.10	4	25	2.5	29	66	23.3	0.14	4	40	4	17.9	68	14.4	0.22	5	63	4	15.7	75	13.6	0.33	5
P (VA)	No-load loss (W)	Voltage % drop Cos φ = 1	Efficiency % Cos φ = 1	U <sub>CC</sub> (%)	I (A) primary loaded	Number of 17.5 mm modules																															
16	2.5	34.6	60	27.5	0.10	4																															
25	2.5	29	66	23.3	0.14	4																															
40	4	17.9	68	14.4	0.22	5																															
63	4	15.7	75	13.6	0.33	5																															
1	4130 96																																				
1	4130 97																																				
1	4130 98																																				

## Operating principle

### Bell transformers

Safety isolating transformer with secondary voltage not permanently exceeding 24 V and for a non permanent usage  
Power to 8 V-12 V or 24 V access control devices such as:

- bell
  - chime
  - door release
  - optical electrical barrier
- Also:
- flood detector
  - temperature rise detector

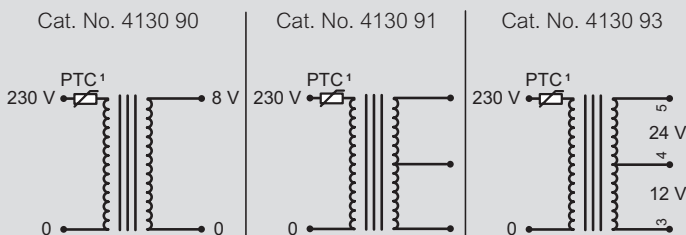

### Safety transformers

Designed to protect people from electric shocks by using extra low voltage (ELV U<sub>sec</sub> ≤ 50 V)  
Power to 12 or 24 V devices such as:

- relay
- modular power contactor
- signalling unit
- latching relay

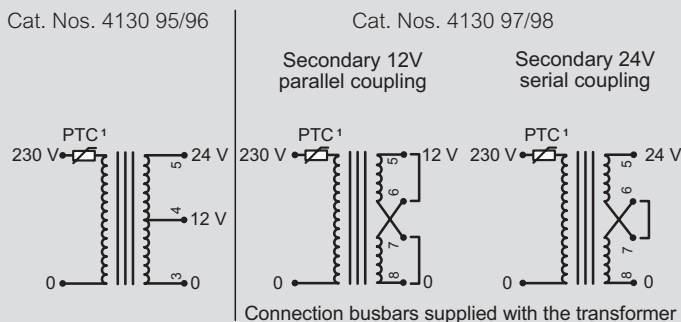

1 : PTC refer to general characteristics

## Fixings

Wall or DIN rail 7.5 or 15 mm<sup>2</sup> depth for 4 module units  
Rail DIN 7.5 or 15 mm<sup>2</sup> depth for 2 and 5 module units

2 : Remove with tool

## Connection

	Primary flexible or rigid	Secondary flexible or rigid
	1 to 4 mm <sup>2</sup>	1 to 4 mm <sup>2</sup>
	1 to 4 mm <sup>2</sup>	1 to 4 mm <sup>2</sup>



# modular DIN rail equipment

## dimensions

### ■ Dimensions

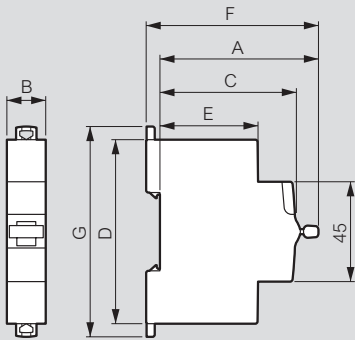

Description	Dimension (mm)										
	A	B				C	D	E	F	G	
		1P	1P+N	2P	3P	4P					
CX <sup>3</sup> Push buttons/ control switches	68	17.7				60	83	44	74	94	
CX <sup>3</sup> contactors up to 25 A	66.3/ 61	17.8	-	17.8	35.6	35.6	61	84.5	44	72.6/ 67.3	94.8
CX <sup>3</sup> contactors 40 A & 63 A	62	-	-	35.6	53.4	53.4	60	83	44	68	94
Auxiliaries for CX <sup>3</sup> contactors	61	9 / 17.8				61	84.5	44	67	84.5	
CX <sup>3</sup> LED indicators	61	17.8	-			61	84.5	44.8	67.3	94.9	

### ■ Dimensions

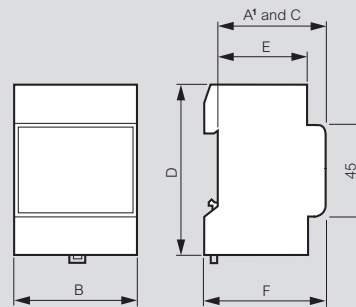

Description		Dimension (mm)					
		A'	B	C	D	E	F
Transformers	Cat. Nos. 4130 90/91	60	36	60	84	44	66
	Cat. No. 4130 93	60	72	60	84	44	66
	Cat. Nos. 4130 95/96	60	72	60	84	44	66
	Cat. Nos. 4130 97/98	60	89	60	95	44	66

1 : Maximum projection



# TIME SWITCHES... MOVE WITH THE TIMES

Legrand's one and two channel time switches are available in digital and analogue versions, ranging from AlphaRex<sup>3</sup> programmable switches with 0.1 second clock precision, to a more simplistic analogue technology with basic switching functions.

## ALPHAREX<sup>3</sup>... THE NEXT GENERATION OF INNOVATION

Available in standard versions and astronomical light control versions, each with PC programmable functionality.

- 0.1 second clock precision – unbeatable accuracy
- Zero crossing switching – reduces stress on the relay / increases longevity of time switch and lamp
- Expanded offset programming - ideal for outdoor signage and street lighting applications
- Expanded cycle functions - for non-lighting applications such as water features and water irrigation
- Preset time and date - no adjustment needed
- High torque terminal blocks - for enhanced safety
- Pin code for weekly devices - prevents unauthorised programming
- Programme back-up via data key – one key fits all devices

See p. 50-52

## PROGRAMMING MADE EASY

AlphaRex<sup>3</sup> can be programmed for standard applications using the push buttons on the device. More expert programming can be achieved either on site or remotely using a PC, data key and Legrand's patented programming software.





## ALPHAREX<sup>3</sup> AT A GLANCE



**Weekly time switch  
1 + 2 channel  
DIN rail mountable**



**Weekly time switch  
with astronomical  
functions  
1 + 2 channel  
DIN rail mountable**



**Yearly time switch  
1 + 2 channel  
DIN rail mountable**

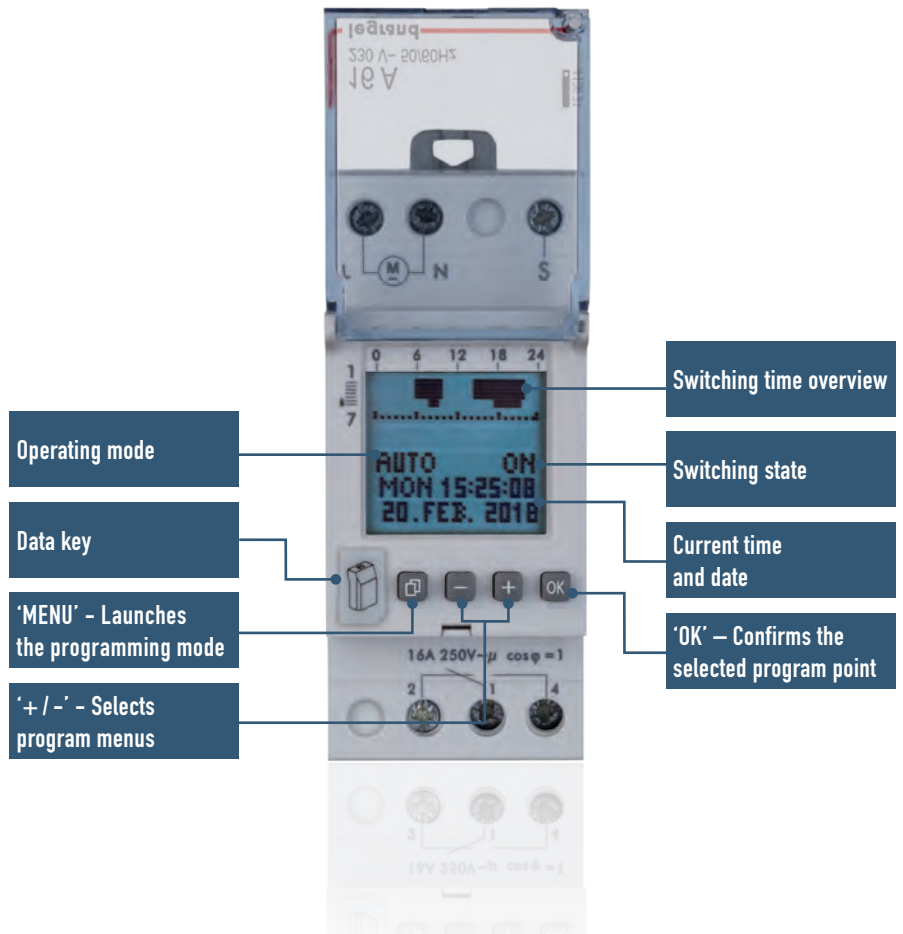

## ALSO AVAILABLE

### DIGITAL



**MicroRex D  
digital time switches**  
DIN rail mountable  
see p. 53



**MaxiRex  
digital time switches**  
Surface mounting  
see p. 54

### ANALOGUE



**MicroRex  
analogue time switches**  
DIN rail mountable  
see p. 55



**MaxiRex and EconoRex  
analogue time switches**  
Surface / panel mounting  
see p. 56

### LIGHTING CONTROL



**Programmable light  
sensitive switch**  
For lighting control  
see p. 57



**Electronic time lag  
switch**  
For lighting control  
see p. 57



4126 31



4128 72



4128 73



4126 57



4128 72



4128 73

**Technical information p. 51**

Conform to EN 60730-1 and EN 60730-2-7  
 Supply voltage : 230 V~ 50/60 Hz  
 Mount on DIN rail EN 60715  
 Text based programming. Programmable in 15 languages  
 Programme directly on time switch keypad or remotely via a PC with Legrand software, USB adaptor and data key  
 Data key enables programmes to be transferred from one unit to another and for programmes to be stored  
 EEPROM memory keeps programmes stored indefinitely  
 Pin code facility to protect programmes from unauthorised changes  
 Time switch accuracy : ±0.1 second per day  
 Zero-crossing switching  
 Automatic summer/winter time correction  
 5 years running reserve  
 Back lit graphic display  
 Operating temperature : -20 °C to +55 °C  
 Protection : IP 20  
 Switching increment : 1 second  
 Shortest switching time : 1 second

**Technical information p. 52**

Conform to EN 60730-1 and EN 60730-2-7  
 Supply voltage : 230 V~ 50/60 Hz  
 Mount on DIN rail EN 60715  
 Text based programming. Programmable in 15 languages  
 Programme directly on time switch keypad or remotely via a PC with Legrand software, USB adaptor and data key  
 Data key enables programmes to be transferred from one unit to another and for programmes to be stored  
 EEPROM memory keeps programmes stored indefinitely  
 Pin code facility to protect programmes from unauthorised changes  
 Time switch accuracy : ±0.1 second per day  
 Zero-crossing switching  
 Automatic summer/winter time correction  
 5 years running reserve  
 Back lit graphic display  
 Operating temperature : -20 °C to +55 °C  
 Protection : IP 20  
 Switching increment : 1 second  
 Shortest switching time : 1 second

Pack	Cat. Nos.	AlphaRex <sup>3</sup>	No. of 17.5 mm modules
1	4126 31	<b>AlphaRex D21 230 V</b> Weekly time switches 24h / 7 day programme time Particularly suited to irregular cycles (e.g. security installations and industrial installations) Random function to simulate presence - programmed switching cycles are shifted at random with a range of ±15 minutes <b>Additional functions :</b> Operating hours counter (for max. 65,535 hours) 1 hour test Cycle function Holiday programme	2
1	4126 41	<b>AlphaRex D22 230 V</b> 24 hr / 7 day two channel 2 x 16 A outputs 2 x 28 programmes	2
<b>Accessories</b>			
1	4128 72	<b>Programming transfer key</b> Enables programmes to be stored and / or transferred from one time switch to another when used with the programming software kit Cat. No. 4128 73 Data key can be stored directly within the time switch	
1	4128 73	<b>Programming software kit</b> Create and read programmes remotely via a PC Transfer programmes via transfer key Cat. No. 4128 72 to time switches Kit comprises : data loader and transfer key Windows® <sup>1</sup> compatible	

Pack	Cat. Nos.	AlphaRex <sup>3</sup> Astro light control	No. of 17.5 mm modules
1	4126 54	<b>AlphaRex Astro D21 230 V</b> Weekly time switches 24h / 7 day programme time Particularly suited to outdoor lighting and street signage applications Enables the daily astronomical calculation of sunrise and sunset by inputting local position or coordinates (no need to install a light sensor) Lights are switched ON and OFF according to sunrise and sunset times, and can be offset by up to ±120 minutes in relation to sunrise and sunset times To save energy, it is also possible to programme an ON and OFF time at night Time saving programming due to pre-set groups of days : Mon-Sun, Mon-Fri, or Sat-Sun and individual selection of days Programmes are shown as a weekly matrix on the graphic display <b>Additional functions :</b> Operating hours counter (for max. 65,535 hours) 1 hour test. Holiday programme <b>Expert mode for additional functions :</b> Cycle function Control input (Cat. No. 4126 54 only) Mains synchronisation Channel switching	2
1	4126 57	<b>AlphaRex Astro D22 230 V</b> 24 hr / 7 day two channel 2 x 16 A outputs. 2 x 28 programmes	2
<b>Accessories</b>			
1	4128 72	<b>Programming transfer key</b> Enables programmes to be stored and / or transferred from one time switch to another when used with the programming software kit Cat. No. 4128 73 Data key can be stored directly within the time switch	
1	4128 73	<b>Programming software kit</b> Create and read programmes remotely via a PC Transfer programmes via transfer key Cat. No. 4128 72 to time switches Kit comprises : data loader and transfer key Windows® <sup>1</sup> compatible	

1 : Windows is a registered trademark of the Microsoft Corporation

1 : Windows is a registered trademark of the Microsoft Corporation

# AlphaRex<sup>3</sup> programmable time switches

digital for rail



## Dimensions (mm)

Cat. Nos. 4126 31/41

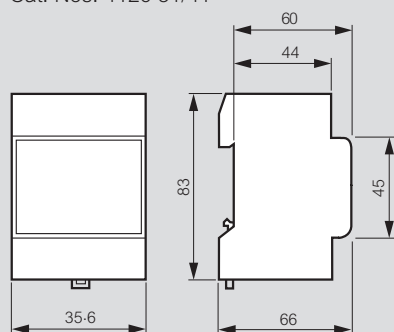

## Wiring diagrams

Cat. No. 4126 31

Cat. No. 4126 41

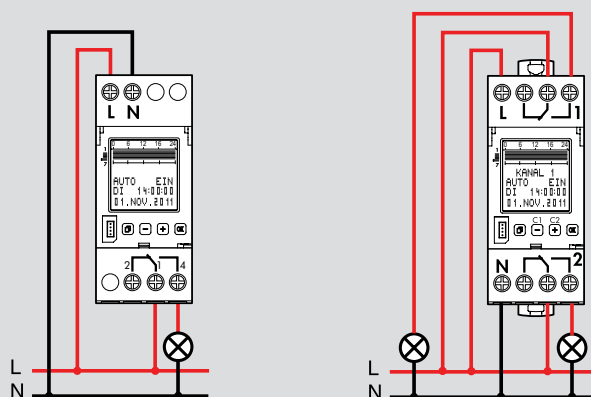

## Technical information

Type Cat. No.	AlphaRex <sup>3</sup> D21 4126 31	AlphaRex <sup>3</sup> D22 4126 41
Supply voltage	230 V~	
Frequency	50/60 Hz	
Programme	24 hour or 7 day	
No. of channels	1	2
Effective power consumption	Approx 1 W	ca 1.5 W
Switching capacity : cos φ = 1	16 A 250 V~	
Contact	1 changeover switch	2 changeover switches
Parallel compensation	600 W max, 70µF	
Switching step	1 second	
Min. switching time	1 second	
Accuracy	±0.1 seconds per day	
Terminal capacity	Single strand 1.5 to 4mm <sup>2</sup>	
Programmes	56	28 per channel
Working reserve <sup>1</sup>	5 years	
Programme memory	EEPROM	
Summer/Winter time	Auto	
IP rating	IP 20	
No. of 17.5 mm modules	2	
Operating temp.	-20 °C to +55 °C	
Storage temp.	-20 °C to +60 °C	

1 : For time and date only

## General information

**AlphaRex<sup>3</sup> D21** Cat. No. 4126 31

- **Start-up** : after applying the supply voltage, the time switch starts automatically with the last selected function. The relay position is set by the current programme
- **Battery backup**
  - **Backlighting** not active
  - **Data key** READ/WRITE only via the menu

- Select menu, back to main menu, Hold down > 1s = operating display
- Confirm selection or load parameters
- Select menu options or set parameters

**AlphaRex<sup>3</sup> D22** Cat. No. 4126 41

- **Start-up** : after applying the supply voltage, the time switch starts automatically with the last selected function. The relay position is set by the current programme
- **Battery backup**
  - **Backlighting** not active
  - **Data key** READ/WRITE only via the menu

- **For safety** : when the time switch is connected to the mains supply the contact should not be used on an isolated low voltage supply and when the time switch is connected to the isolated voltage supply the contact should not be used on the mains supply

- Select menu, back to main menu, Hold down > 1s = operating display
- Confirm selection or load parameters
- C1 C2
  - Select menu options or set parameters
  - Channel selection



## Dimensions (mm)

Cat. Nos. 4126 54/57

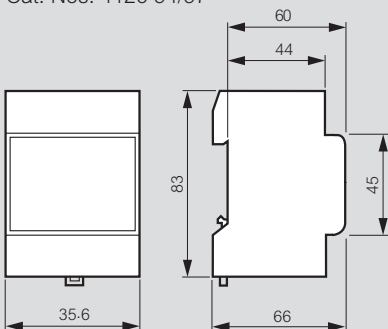

## Wiring diagrams

Cat. No. 4126 54

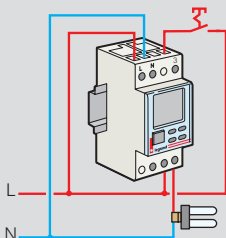

Cat. No. 4126 57

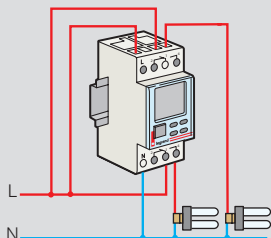

Output closing and breaking times are calculated based on the date, the actual time when the device was switched on and geographical coordinates of the actual location

Cat. No. 4126 54

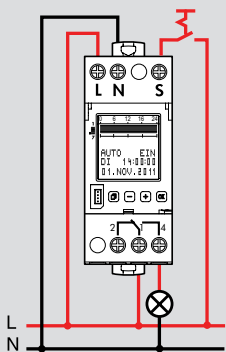

Cat. No. 4126 57

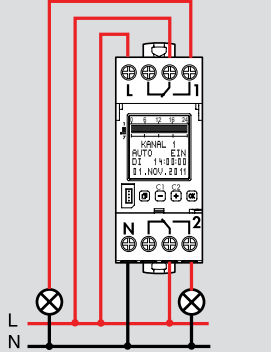

## General information

**AlphaRex<sup>3</sup> Astro D21** Cat. No. 4126 54

• **Start-up** : after applying the supply voltage, the time switch starts automatically with the last selected function. The relay position is set by the current programme

• **Battery backup**

- **Backlighting** not active
- **Data key** READ/WRITE only via the menu

Select menu, back to main menu, Hold down > 1s = operating display

Confirm selection or load parameters

Select menu options or set parameters

## Technical information

Type Cat. No.	AlphaRex <sup>3</sup> Astro D21 4126 54	AlphaRex <sup>3</sup> Astro D22 4126 57
Supply voltage	230 V~	
Frequency	50/60 Hz	
Programme	24 hour or 7 day	
No. of channels	1	2
Effective power consumption	1 W	1.5 W
Switching capacity : cos φ = 1	16 A 250 V~	
Contact	1 changeover switch	2 changeover switches
Min. prog. setting	1 second	
Accuracy	±0.1 seconds per day	
Terminal capacity	Single strand 1.5 to 4mm <sup>2</sup>	
Programmes	56	28 per channel
Control-cable length	Max. 50 m	
Control signal	230 V AC/2 mA	
Control-pulse duration	100 to 200 ms	
Delay time	0 to 23 h 59 min 59 s	
Local coordinates	Resolution 1°/1' in EXPERT-Mode	
Working reserve <sup>1</sup>	5 years	
Programme memory	EEPROM	
Summer/Winter time	Auto	
IP rating	IP 20	
No. of 17.5 mm modules	2	
Operating temp.	-20 °C to +55 °C	
Storage temp.	-20 °C to +60 °C	

1 : For time and date only

**AlphaRex<sup>3</sup> Astro D22** Cat. No. 4126 57

• **Start-up** : after applying the supply voltage, the time switch starts automatically with the last selected function. The relay position is set by the current programme

• **Battery backup**

- **Backlighting** not active
- **Data key** READ/WRITE only via the menu

• **For safety** : when the time switch is connected to the mains supply the contact should not be used on an isolated low voltage supply and when the time switch is connected to the isolated voltage supply the contact should not be used on the mains supply

Select menu, back to main menu, Hold down > 1s = operating display

Confirm selection or load parameters

C1 C2  
 Select menu options or set parameters  
 Channel selection

# MicroRex D digital time switches



for rail



Technical information **opposite**

Conform to EN 60730-1 and EN 60730-2-7  
LCD digital display  
Mount on DIN rail EN 60715

Pack	Cat. Nos.	MicroRex D Plus	No. of 17.5 mm modules
1	6037 70	UK specific English display Supply voltage : 220 V~ 50 Hz CE approved 16 A 56 programmes per channel 3 years working reserve Accuracy : 1 second clock precision Switching precision : 1 minute	2
1	6037 71	<b>MicroRex D21 Plus</b> 1 channel <b>MicroRex D22 Plus</b> 2 channels	2
1	0037 10	<b>MicroRex D</b> Supply voltage : 230 V~ 50/60 Hz Working reserve : 100 hours Accuracy : ±2.5 seconds per day <b>7 day programme</b> Programmable for 1 minute min. at 1 minute steps <b>Additional features :</b> Manual advance/override (ON-OFF) Automatic override (ON-OFF) for holidays, weekends or bank holidays up to 99 days successively Automatic summer/winter setting <b>MicroRex D11 – 1 module</b> <b>Power supply 230 V~ - 50/60 Hz</b> Time-saving programming by selection of daily blocks. Daily blocks individually adjustable or selected from preset blocks Mo-Fr and Mo-Su Permanent ON or OFF Circuit anticipation Power reserve 3 years for date, time and switching program Accuracy +/- 1 sec./Day <b>1 NO contact</b> 250 V/50 Hz 16 A - cos φ = 1 28 programmes Shortest switching-time 1 min	1

## Technical information

Type Cat. No.	MicroRex D21 Plus 6037 70	MicroRex D22 Plus 6037 71	MicroRex D11 0037 10
<b>Programme</b>	24 hour or 7 day		
<b>No. of channels</b>	1	2	1
<b>No. of ON-OFF actions per day/week</b>	28	2 x 14	8
<b>Switching cap :</b> <b>cos φ = 1</b> <b>incandescent lamp</b> <b>cos φ = 0.6</b>	16 A 5 A 8 A		16 A 4 A 10 A
<b>Contact</b>	1 c/o	2 c/o	1 c/o
<b>Terminal capacity</b>	1 - 4 mm <sup>2</sup> single/0.5 - 2.5 mm <sup>2</sup> stranded		
<b>IP rating</b>	IP 20		
<b>Min. prog. time</b>	1 minute		
<b>Switching step</b>	1 minute		
<b>Accuracy</b>	±1 second per day		±2.5 sec/d
<b>Working reserve<sup>1</sup></b>	3 years		3 years
<b>Prog. memory</b>	EEPROM		-
<b>Manual switching</b>	Override and permanent		
<b>No. of 17.5 mm modules</b>	2	1	
<b>Operating temp.</b>	-20 °C to +55 °C		-10 °C to +55 °C
<b>Storage temp.</b>	-20 °C to +60 °C		-
<b>Weight</b>	137 g		100 g

1 : For time and date only

## Dimensions (mm) and wiring diagrams

### MicroRex D21/D22 Plus

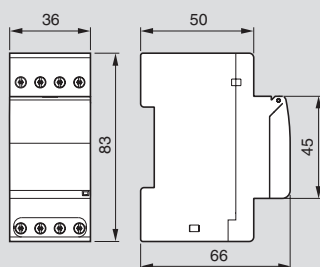

### Wiring diagram

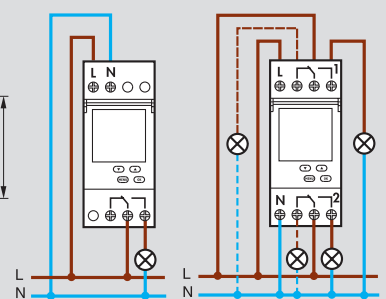

### Wiring diagram

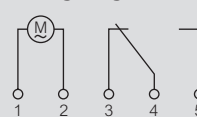

### MicroRex D11

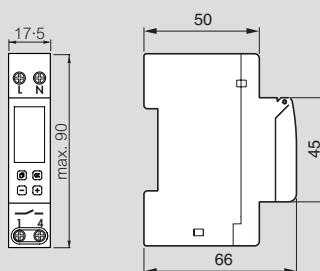

# MaxiRex digital time switches

surface or 72 x 72 mm panel mounting



0496 82

Technical information **opposite**

Conform to EN 60730-1 and EN 60730-2-7

Supply voltage : 230 V~ 50/60 Hz

Accuracy : ±1 second per day

LCD digital display

Programmable for 1 minute minimum at 1 minute intervals

Panel and DIN rail mounting :

- can be panel mounted using Cat. No. 0498 32

- can be clipped to DIN rail using Cat. No. 0044 09

Pack	Cat. Nos.	MaxiRex D Plus
1	0496 80	<p>Working reserve : 6 years Programmable for 1 minute min. at 1 minute steps either as 24 hour/7 day using pre-set groups of days</p> <p>One programme consists of 1 "ON" and 1 "OFF" time and the allocation of any day of the week or a combination of days. Plus the selected channel</p> <p><i>Example :</i>            Prog. 1 On 07.00hrs Off 08.15hrs Mon-Fri Ch1            Prog. 2 On 16.00hrs Off 20.15hrs Mon-Fri Ch2            Prog. 3 On 10.00hrs Off 16.15hrs Sat-Sun Ch1</p> <p><b>Additional features :</b>            EEPROM memory stores programme indefinitely            Optional automatic summer/winter time change            Manual override (ON or OFF)            Automatic advance (changes contact position until next automatic ON time)</p>
1	0496 82	<p><b>MaxiRex D72/1 Plus</b>            24 hour or 7 day            28 programme            1 channel            1 x 16 A voltage free c/o contact</p> <p><b>MaxiRex D72/2 Plus</b>            24 hour or 7 day            2 x 14 programme            2 channel            2 x 8 A voltage free c/o contacts</p>
5	0498 32	<p><b>Fixing accessories</b></p> <p>Clip-on support frame for panel mounting</p>
5	0044 09	

## Technical information

Type Cat. No.	MaxiRex D72/1 Plus 0496 80	MaxiRex D72/2 Plus 0496 82
Programme	24 hour or 7 day	
No. of channels	1	2
No. of ON-OFF actions per day	28	2 x 14
Switching capacity : cos φ = 1 incandescent lamp cos φ = 0.6	16 A 5 A 8 A	8 A 3.5 A 4 A
Contact	1 changeover switch	2 changeover switches
Min. prog. time	1 minute	
Switching step	1 minute	
Accuracy	±1 second per day	
Working reserve <sup>1</sup>	6 years	
Programme memory	EEPROM	
Manual switching	Override and permanent	
Operating temp.	-20 °C to +55 °C	
Storage temp.	-20 °C to +60 °C	
Weight	178 g	204 g

<sup>1</sup> : For time and date only

## Dimensions (mm)

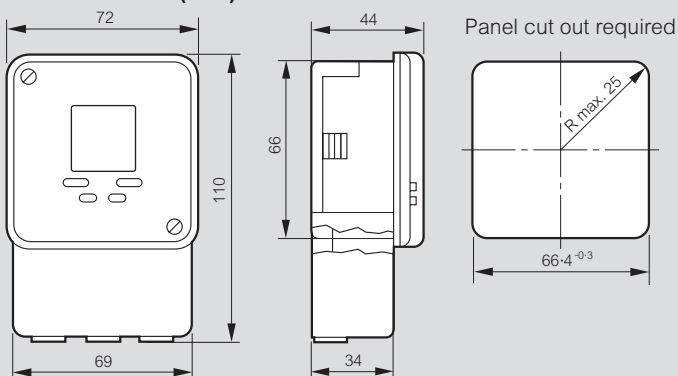

## Wiring diagrams

### MaxiRex D72/1 Plus

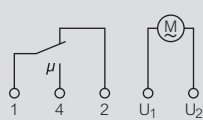

### MaxiRex D72/2 Plus

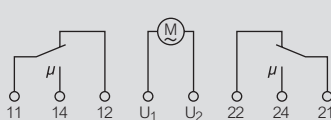

### MaxiRex D72/2 Plus

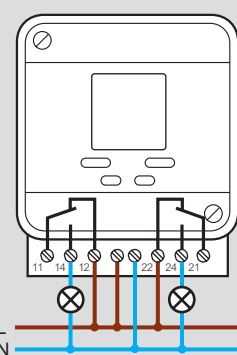

## Mounting options

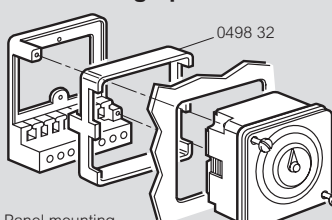

Panel mounting with support Cat. No. 0498 32 to be ordered separately

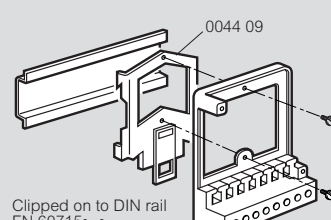

Clipped on to DIN rail EN 60715 Adaptor to be ordered separately (Cat. No. 0044 09)



# MicroRex analogue time switches

for rail



4127 90

4127 95

## Technical information **opposite**

Conform to EN 60730-1 and EN 60730-2-7  
 Programmed via captive segment  
 Supply voltage : 230 V~ 50/60 Hz  
 1 x 16 A output  
 Manual changeover to summer/winter time  
 Mount on DIN rail EN 60715

Pack	Cat. Nos.	Daily programme
1	4127 80	24 hour programme One segment : 15 minutes Switching accuracy : ± 5 minutes
		<b>T11 Daily</b> 1 channel Without working reserve N/O contact Minimum switching time : 15 minutes Vertical dial
		<b>QT11 Daily</b> 1 channel With 100 hr working reserve N/O contact Minimum switching time : 15 minutes Vertical dial
		<b>T31 Daily</b> 1 channel Without working reserve Changeover switch Minimum switching time : 30 minutes Horizontal dial
1	4128 12	<b>QT31 Daily</b> 1 channel With 100 hr working reserve Changeover switch Minimum switching time : 30 minutes Horizontal dial
		<b>QW11 Weekly</b> 1 channel With 100 hr working reserve N/O contact Minimum switching time : 2 hours Vertical dial
1	4127 95	<b>QW31 Weekly</b> 1 channel With 100 hr working reserve Changeover switch Minimum switching time : 4 hours Horizontal dial

No. of 17.5 mm modules  
1

1

3

3

No. of 17.5 mm modules  
1

3

## Technical information

Cat. Nos.	Programme	Segment	Min. switching time	Working reserve	16 A output via contact		No. of modules
					N/O	Chang. S.	
4128 12	24 h	15 min	30 min	without	-	1	3
4128 13	24 h	15 min	30 min	100 h	-	1	3
4127 80	24 h	15 min	15 min	without	1	-	1
4127 90	24 h	15 min	15 min	100 h	1	-	1
4127 94	7 d	2 h	2 h	100 h	1	-	1
4127 95	7 d	2 h	4 h	100 h	-	1	3

## Wiring diagrams

Cat. Nos. 4127 80/90/94

Cat. Nos. 4128 12/13/4127 95

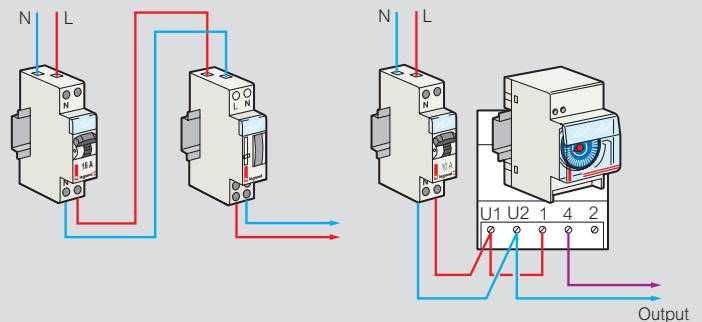

Output closing and breaking times are calculated based on the date, the actual time when the device was switched and on geographical coordinates of the actual location

## Dimensions (mm)

Cat. Nos. 4127 80/90/94

Cat. Nos. 4128 12/13/4127 95

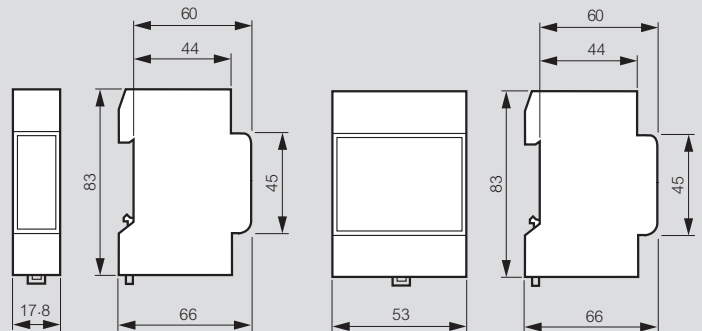

# MaxiRex and EconoRex analogue time switches

surface and panel mounting



Technical information **opposite**

Pack	Cat. Nos.	MaxiRex
1	0497 50	<p>Conform to EN 60730-1 and EN 60730-2-7 Supply voltage : 230 V<math>\sim</math> <math>\pm</math>10% 3 position changeover switch With manual override Voltage free contacts Mounting options : - can be surface mounted - can be panel mounted using Cat. No. 0498 32 - can be clipped to DIN rail using Cat. No. 0044 09</p> <p>With 72 x 72 mm display to DIN EN 60715 Part C</p> <p><b>24 hour programme</b> Programmable for 30 minutes minimum at 10 minute intervals Accuracy : <math>\pm</math>5 minutes per day</p> <p><b>MaxiRex T</b> Without working reserve – 50 Hz</p>
1	0497 54	<p><b>MaxiRex QT</b> <b>7 day programme</b> Programmable for 3 hours minimum at 1 hour intervals Accuracy : <math>\pm</math>30 minutes per day</p> <p>With 100 hr working reserve – 50/60 Hz</p>
5	0498 32	<p><b>Fixing accessories</b></p> <p>Clip-on support frame for panel mounting DIN rail adaptor</p>
5	0044 09	
1	0499 83	<p><b>EconoRex MT</b> Conforms to EN 60730-1 and EN 60730-2-7 Supply voltage : 230 V<math>\sim</math> 50 Hz Mounting options : can be panel mounted</p> <p><b>EconoRex MT</b> BTAP without working reserve 20 A output Shortest switching step : 20 minutes Switching accuracy : <math>\pm</math> 5 minutes</p>

## Technical information

Type Cat. No.	MaxiRex T 0497 50	MaxiRex QT 0497 54	EconoRex MT 0499 83
Supply voltage	230 V $\sim$ +10% -15%		
Frequency	50 Hz	50/60Hz	50 Hz
Switching capacity : cos $\phi$ = 1 cos $\phi$ = 0.6 incand. lamp	16 A 10 A 1 000 W		16 A 8 A 1 000 W
Contact	1 c/o SPDT	1 c/o SPDT	1 c/o
Working reserve	None	100 hrs	None
Min. switching time	30 mins		15 mins
Interval	10 mins		15 mins
IP rating	IP 30		
Storage temp.	-10 °C to +60 °C		
Operating temp.	0 °C to +55 °C		

## Dimensions (mm)

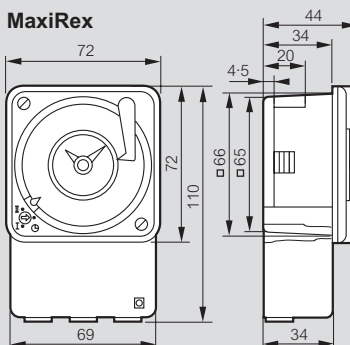

## MaxiRex mounting

### Wall mounting

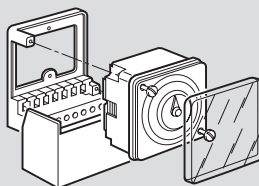

### Panel mounting

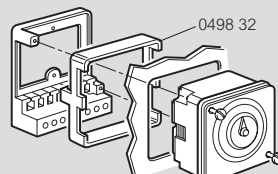

Panel mounting with support  
Cat. No. 0498 32  
to be ordered separately

### DIN rail mounting

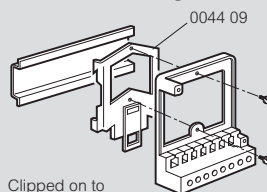

Clipped on to  
DIN rail EN 60715  
Adaptor to be ordered  
separately (Cat. No. 0044 09)

## Wiring diagrams

### MaxiRex and EconoRex

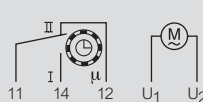

## EconoRex mounting

### Panel mounting

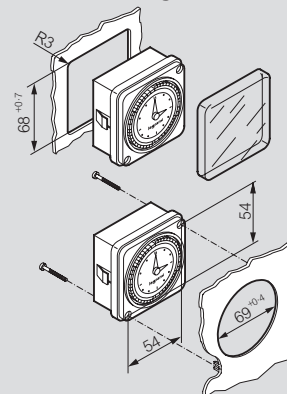

# light sensitive control and electronic time lag switches

digital for rail



4126 26



4126 02

## Technical information opposite

Pack	Cat. Nos.	Programmable light sensitive switch
1	4126 26	<p>Can be used to switch a lighting circuit "ON" and "OFF" based on light conditions (nightfall, daybreak)                      Supplied with IP 65 weatherproof photoelectric cell                      Power supply : 230 V<math>\sim</math> - 50/60 Hz</p> <p><b>Standard</b></p> <p>56 programmes possible : daily, weekly or yearly programmes                      Output 16 A - 250 V<math>\sim</math> - <math>\mu</math> cos <math>\varphi</math> = 1                      2000 W incandescent                      2000 VA series compensated fluorescent                      1000 W energy-saving bulb                      Integrated hour counter                      High precision clock : <math>\pm</math> 0.1 sec per day at 25°C                      Working reserve : 5 years                      Adjustable from 3 to 100 000 lux                      Automatic changeover between summer/winter time                      Number of modules : 2                      Supplied with IP 65 photoelectric cell                      Cat. No. 4128 58<sup>2</sup>                      Programmed using programme transfer key                      Cat. No. 4128 72 (below)</p>
1	4128 72	<p><b>Accessories</b></p> <p><b>Programming transfer key</b></p> <p>Enables programmes to be stored and / or transferred from one time switch to another when used with the programming software kit Cat. No. 4128 73                      Data key can be stored directly within the time switch</p> <p><b>Programming software kit</b></p> <p>Create and read programmes remotely via a PC                      Transfer programmes via transfer key Cat. No. 4128 72 to time switches                      Kit comprises : data loader and transfer key                      Windows<sup>®1</sup> compatible</p>
10	4126 02	<p><b>Electronic time-lag switch</b></p> <p>For staircase lighting. Switches a lighting circuit on and off from remote switch for a specific time                      DIN rail mountable                      Self-protection in the event of a blocked push button</p> <p>Power supply : 230 V<math>\sim</math> - 50/60 Hz                      2 000 W incandescent                      2 000 W halogen - 230 V<math>\sim</math>                      1 000 VA fluo-series compensated                      120 VA fluo-parallel compensated 14 <math>\mu</math>F                      100 VA compact fluorescent                      1 000 W energy saving lamp                      Adjustable from 0.5 seconds to 10 minutes</p> <p>Output : 16 A - 250 V<math>\sim</math> - cos <math>\varphi</math> = 1                      3 wire or 4 wire connection                      Manual override contact                      Number of modules : 1</p>

## Technical information

Type Cat. No.	Light sensitive switch 4126 26	Electronic time-lag 4126 02
Supply voltage	230 V $\sim$	
Frequency	50/60 Hz	
Consumption	~1 W	0.8 W
Contact rating	Changeover contact 16 A 250 V $\sim$ $\mu$ cos $\varphi$ = 1	$\mu$ 16 A cos $\varphi$ = 1/250 V $\sim$
Accuracy	$\pm$ 0.1 second per day	$\pm$ 2.5 seconds per day
Terminal capacity	Single strand 1.5 to 4 mm <sup>2</sup>	Multi strand 1.5 to 2.5 mm <sup>2</sup>
Program pictures	56	
Battery reserve	5 years	100 minutes
Operating temp.	-20 °C to +55 °C	-20 °C to +55 °C
Storage temp.	-20 °C to +60 °C	-20 °C to +70 °C
Setting range	1 lx ... 100 klx	
IP rating	IP 20	IP 30

## Time-lag switch

Allows :

- unlimited numbers of unlit push-buttons
  - 50 lit push-buttons max. (neon R = 1 mA max.)
- Constant lighting possible

### 3 wire connection

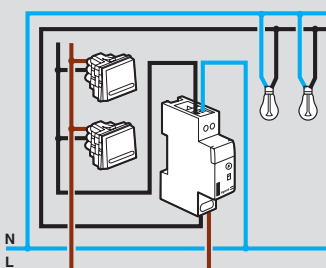

### 4 wire connection

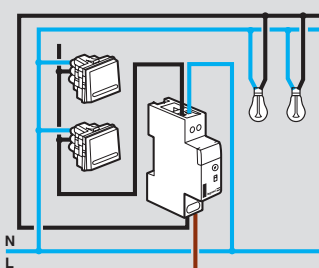

1 : Windows is a registered trademark of the Microsoft Corporation  
 2 : Contact us on +44 (0) 370 608 9020

Cat. Nos.	Page No.	Cat. Nos.	Page No.	Cat. Nos.	Page No.	Cat. Nos.	Page No.	Cat. Nos.	Page No.	Cat. Nos.	Page No.	Cat. Nos.	Page No.
<b>0010 00</b>		0130 06	23	0153 32	22	<b>0200 00</b>		0428 77	36	4062 58	6, 10, 12	4088 70	4
		08 -	-	40 -	-			99 -	-			72 -	-
0016 65	21	10 -	-	50 -	-	0215 01	20	0442 31	34	60 -	-	73 -	-
90 -	-	12 -	-	63 -	-	03 -	-	32 -	-	62 -	-	74 -	-
91 -	-	16 -	-	80 -	-	04 -	-	33 -	-	66 -	-	75 -	-
0037 10	53	20 -	-	96 -	-	05 -	-	34 -	-	4063 03	6, 10, 12, 21, 28, 31	76 -	-
0044 09	54, 56	25 -	-	97 -	-	0216 00	20	35 -	-			78 -	-
0044 16	36	95 -	-	0160 25	24	01 -	-	36 -	-	04 6, 28		4089 35	4
0046 70	14	0133 00	22, 23	30 -	-	04 -	-	37 -	-	05 6, 28		36 -	-
0046 89	15	01 -	22	35 -	-	05 -	-	38 -	-	07 6, 10, 12, 21, 42, 43		37 -	-
0049 96	21	02 -	-	40 -	-	0225 12	29	39 -	-	13 6, 10, 12, 21, 28, 31		39 -	-
		04 -	-	45 -	-	15 -	-	40 -	-			40 -	-
<b>0050 00</b>		06 -	-	50 -	-	20 -	-	61 -	-			42 -	-
		08 -	-	0163 18	24	22 -	-	62 -	-	4064 00	28	43 -	-
0057 99	21	10 -	-	20 -	-	34 -	-	63 -	-	01 -	-	44 -	-
0058 04	20	12 -	-	25 -	-	39 -	-	64 -	-	03 -	-	45 -	-
06 -	-	16 -	-	30 -	-	51 -	-	65 -	-	11 -	-	46 -	-
08 -	-	20 -	-	35 -	-	53 -	-	66 -	-	12 -	-	48 -	-
16 -	-	25 -	-	40 -	-	0227 04	29	67 -	-	23 -	-	84 -	-
18 -	-	94 -	-	45 -	-	07 -	-	68 -	-	31 -	-	85 -	-
28 -	-	0140 04	23	50 -	-	22 -	-	69 -	-	32 -	-	86 -	-
38 -	-	06 -	-	55 -	-	32 -	-	70 -	-	34 -	-	88 -	-
48 -	-	10 -	-	0165 35	24	98 -	-	71 -	-	36 -	-	89 -	-
		12 -	-	40 -	-			0470 01	40	38 -	-	91 -	-
		16 -	-	45 -	-	<b>0400 00</b>		02 -	-	40 -	-	92 -	-
<b>0100 00</b>		20 -	-	50 -	-			03 -	-	41 -	-	93 -	-
		25 -	-	55 -	-	0427 85	36	04 -	-	50 -	-	94 -	-
0102 02	22	32 -	-	0168 04	24	86 -	-	20 -	-	53 -	-	95 -	-
05 -	-	40 -	-	45 -	-	87 -	-	21 -	-	55 -	-	96 -	-
06 -	-	45 -	-	50 -	-	88 -	-	22 -	-	57 -	-	97 -	-
10 -	-	50 -	-	55 -	-	89 -	-	23 -	-	59 -	-	4090 58	4
12 -	-	0143 00	22, 23	60 -	-	90 -	-	24 -	-	60 -	-	62 -	-
16 -	-	02 -	22	65 -	-	92 -	-	25 -	-	61 -	-	63 -	-
20 -	-	04 -	-	0170 50	24	428 40	36	0496 80	54	70 -	-	65 -	-
25 -	-	06 -	-	55 -	-	41 -	-	82 -	-	75 -	-	66 -	-
30 -	-	10 -	-	60 -	-	42 -	-	0497 50	56	77 -	-	67 -	-
50 -	-	16 -	-	0173 04	24	43 -	-	54 -	-	79 -	-	68 -	-
63 -	-	20 -	-	50 -	-	44 -	-	0498 32	54, 56	80 -	-	69 -	-
96 -	-	25 -	-	55 -	-	45 -	-	0499 83	56	81 -	-	70 -	-
0120 02	23	32 -	-	60 -	-	47 -	-			90 -	-	71 -	-
04 -	-	40 -	-	65 -	-	55 -	-	<b>4000 00</b>		95 -	-	4091 07	4
06 -	-	50 -	-	0175 60	24	56 -	-			4079 63	5	08 -	-
10 -	-	0150 32	23	65 -	-	57 -	-	4049 05	21	65 -	-	09 -	-
0123 00	22, 23	40 -	-	70 -	-	58 -	-	06 -	-	66 -	-	11 -	-
01 -	22	50 -	-	0178 04	24	59 -	-	26 -	-	4080 23	5	12 -	-
02 -	-	63 -	-	60 -	-	60 -	-	37 -	-	25 -	-	14 -	-
04 -	-	80 -	-	65 -	-	61 -	-	38 -	-	26 -	-	15 -	-
06 -	-	96 -	-	70 -	-	62 -	-	39 -	-	81 -	-	16 -	-
08 -	-	97 -	-	75 -	-	70 -	-	42 -	-	83 -	-	17 -	-
10 -	-	0153 00	22, 23	0181 04	24	71 -	-	43 -	-	84 -	-	18 -	-
12 -	-	10 -	22	0199 02	24	72 -	-	44 -	-	4088 65	4	19 -	-
16 -	-	16 -	-			73 -	-	88 -	-	66 -	-	20 -	-
0130 01	23	20 -	-			74 -	-	89 -	-	67 -	-	40 -	-
02 -	-	25 -	-			75 -	-			69 -	-	95 -	-
04 -	-												

Cat. Nos.	Page No.	Cat. Nos.	Page No.	Cat. Nos.	Page No.	Cat. Nos.	Page No.	Cat. Nos.	Page No.	Cat. Nos.	Page No.	Cat. Nos.	Page No.
4091 96	4	4094 44	5	4110 21	11	4115 57	9	4120 60	15	4121 69	16	4129 29	45
97	-	47	-	22	-	69	-	65	14	4124 29	42, 43	30	-
99	-	49	-	24	-	70	-	68	-	30	-	31	-
4092 00	4	51	-	25	-	71	-	69	-	31	-	32	-
02	-	52	-	26	-	72	-	74	-	4125 03	42	33	-
03	-	53	-	27	-	84	-	75	-	05	-	34	-
04	-	54	-	28	-	4117 02	9	80	-	21	-	35	-
05	-	55	-	4111 49	11	03	-	81	-	24	-	4130 90	46
06	-	56	-	50	-	04	-	82	-	33	-	91	-
07	-	57	-	51	-	05	-	83	-	35	-	93	-
08	-	58	-	57	-	12	-	90	-	36	-	95	-
28	-	59	-	58	-	13	-	91	-	44	43	96	-
29	-	60	-	59	-	14	-	92	-	45	-	97	-
30	-	92	-	60	-	15	-	93	-	47	-	98	-
47	-	95	-	61	-	22	-	4121 01	16	49	-	4149 38	15
48	-	97	-	62	-	23	-	02	-	50	-	39	-
49	-	99	-	63	-	24	-	03	-	53	-	47	-
51	-	4095 00	5	64	-	25	-	04	-	56	-	48	-
52	-	01	-	85	-	32	-	05	-	4126 02	57	49	-
54	4	02	-	86	-	33	-	06	-	26	-	4189 80	12
55	-	03	-	87	-	34	-	07	-	31	50	81	-
56	-	04	-	88	-	35	-	12	-	41	-	82	-
57	-	05	-	89	-	45	-	14	-	54	-	83	-
58	-	06	-	90	-	46	-	16	-	57	-	84	-
59	-	07	-	91	-	59	-	17	-	4127 80	55	85	-
60	-	08	-	92	-	60	-	19	-	90	-	86	-
80	-	26	-	4112 04	11	61	-	23	-	94	-	87	-
81	-	29	-	05	-	62	-	24	-	95	-		
82	-	31	-	06	-	79	-	25	-	4128 12	55	<b>6000 00</b>	
4093 29	4	33	-	07	-	80	-	26	-	13	-		
30	-	34	-	08	-	81	-	31	-	72	50, 57	6037 70	53
31	-	35	-	09	-	82	-	32	-	73	-	71	-
33	-	36	-	10	-	83	-	33	-	4129 00	31	6040 77	45
34	-	37	-	11	-	90	-	36	-	01	-	78	-
36	-	38	-	4115 00	9	91	-	38	-	02	-	79	-
37	-	39	-	04	-	92	-	39	-	03	-	6423 62	36
38	-	40	-	05	-	4118 00	9	42	-	04	-	63	-
39	-	41	-	06	-	01	-	46	-	4129 08	45	64	-
40	-	42	-	07	-	4120 00	14	47	-	09	-	65	-
41	-	4109 18	11	08	-	02	-	49	-	10	-	66	-
42	-	19	-	14	-	04	-	50	-	11	-	68	-
62	-	21	-	15	-	40	-	51	-	12	-		
63	-	22	-	16	-	41	-	52	-	13	-		
64	-	24	-	17	-	42	-	53	-	14	-		
4094 25	5	25	-	24	-	43	-	54	-	15	-		
28	-	93	-	25	-	45	-	57	-	16	-		
30	-	97	-	26	-	47	15	58	-	21	-		
32	-	99	-	27	-	51	14	62	-	22	-		
33	-	4110 00	11	37	-	52	15	63	-	23	-		
34	-	02	-	43	-	53	-	64	-	24	-		
35	-	03	-	50	-	55	-	65	-	25	-		
36	-	04	-	54	-	57	-	66	-	26	-		
37	-	05	-	55	-	58	-	67	-	27	-		
38	-	06	-	56	-	59	-	68	-	28	-		

## Cross-reference table

PROTECTION, CONTROL & MEASUREMENT				
Range	Description	Old Cat. No.	New Cat. No. / status	Page No.
RCDs - DX <sup>3</sup> -ID	RCD - A Type 100mA - nominal rating 25 A	4117 69	P	N/A
RCDs - DX <sup>3</sup> -ID	RCD - A Type 100mA - nominal rating 40 A	4117 70	P	N/A
RCDs - DX <sup>3</sup> -ID	RCD - A Type 100mA - nominal rating 63 A	4117 71	P	N/A
RCDs - DX <sup>3</sup> -ID	RCD - A Type 100mA - nominal rating 80 A	4117 72	P	N/A
RCDs - DX <sup>3</sup> -ID	RCD - A Type 100mA - nominal rating 100 A	4117 73	P	N/A
RCBOs DX <sup>TM</sup> 10000	Single pole - 230 V - C curve - AC Type 30 mA - nominal rating 10 A	6064 10	4189 81	12
RCBOs DX <sup>TM</sup> 10000	Single pole - 230 V - C curve - AC Type 30 mA - nominal rating 16 A	6064 11	4189 82	12
RCBOs DX <sup>TM</sup> 10000	Single pole - 230 V - C curve - AC Type 30 mA - nominal rating 20 A	6064 12	4189 83	12
RCBOs DX <sup>TM</sup> 10000	Single pole - 230 V - C curve - AC Type 30 mA - nominal rating 25 A	6064 13	4189 84	12
RCBOs DX <sup>TM</sup> 10000	Single pole - 230 V - C curve - AC Type 30 mA - nominal rating 3 A	6064 14	4189 85	12
RCBOs DX <sup>TM</sup> 10000	Single pole - 230 V - C curve - AC Type 30 mA - nominal rating 45 A	6064 15	4189 87	12
EDMX <sup>3</sup> electrical energy meters	Single phase meter - direct connection - 63 / A 2 modules / pulse output / Non-MID	0046 72	P	N/A
EDMX <sup>3</sup> electrical energy meters	Three phase meter - direct connection - 63 A / 4 modules / pulse output / Non-MID	0046 73	P	N/A
EDMX <sup>3</sup> electrical energy meters	Three phase meter - connection with CT - 5 A / 4 modules / pulse output / Non-MID	0046 74	P	N/A
EDMX <sup>3</sup> multi-function measuring units	EMDX <sup>3</sup> modular - pulse unit	0046 75	P	N/A
EDMX <sup>3</sup> multi-function measuring units	EMDX <sup>3</sup> modular - RS 485 unit	0046 76	P	N/A
EDMX <sup>3</sup> electrical energy meters	Single phase meter - direct connection - 63 A / 2 modules / RS 485 output / Non-MID	0046 77	P	N/A
EDMX <sup>3</sup> electrical energy meters	Single phase meter - direct connection - 63 A / 2 modules / pulse output / MID certified	0046 78	P	N/A
EDMX <sup>3</sup> electrical energy meters	Single phase meter - direct connection - 63 A / 2 modules / RS 485 output / MID certified	0046 79	P	N/A
EDMX <sup>3</sup> electrical energy meters	Three phase meter - direct connection - 63 A / 4 modules / RS 485 output / Non-MID	0046 80	P	N/A
EDMX <sup>3</sup> electrical energy meters	Single phase meter - direct connection - 36 A / 2 modules / pulse output / Non-MID	0046 81	P	N/A
EDMX <sup>3</sup> electrical energy meters	Three phase meter - direct connection - 63 A / 4 modules / pulse output / MID certified	0046 82	P	N/A
EDMX <sup>3</sup> electrical energy meters	Three phase meter - direct connection - 63 A / 4 modules / RS 485 output / MID certified	0046 83	P	N/A
EDMX <sup>3</sup> electrical energy meters	Three phase meter - connection with CT - 5 A / 4 modules / RS 485 and pulse output / Non-MID	0046 84	P	N/A
EDMX <sup>3</sup> electrical energy meters	Three phase meter - connection with CT - 5 A / 4 modules / pulse output / MID certified	0046 85	P	N/A
EDMX <sup>3</sup> electrical energy meters	Three phase meter - connection with CT - 5 A / 4 modules / RS 485 and pulse output / MID certified	0046 86	P	N/A
EDMX <sup>3</sup> electrical energy meters	Concentrator - 4 modules	0046 87	P	N/A
EDMX <sup>3</sup> - access multi-function measuring units	Multi-function measuring unit - 96 x 96 x60 mm	0146 68	P	N/A
EDMX <sup>3</sup> - premium multi-function measuring units	Multi-function measuring unit - 96 x 96 x60 mm	0146 69	P	N/A
EDMX <sup>3</sup> - access multi-function measuring units	Modules for access multi-function measuring unit - RS 485 communication module MODBUS link	0146 71	P	N/A
EDMX <sup>3</sup> - access multi-function measuring units	Modules for access multi-function measuring unit - 1 output module	0146 72	P	N/A
EDMX <sup>3</sup> - premium multi-function measuring units	Modules for premium multi-function measuring unit - RS 485 communication module MODBUS link	0146 73	P	N/A
EDMX <sup>3</sup> - premium multi-function measuring units	Modules for premium multi-function measuring unit - storage module	0146 74	P	N/A
EDMX <sup>3</sup> - premium multi-function measuring units	Modules for premium multi-function measuring unit - module with 2 inputs / 2 outputs	0146 75	P	N/A
EDMX <sup>3</sup> - premium multi-function measuring units	Modules for premium multi-function measuring unit - temperature module	0146 77	P	N/A
EDMX <sup>3</sup> - multi-function measuring units	Web server - for 32 metering points	0261 78	P	N/A
EDMX <sup>3</sup> - multi-function measuring units	Web server - for unlimited number of metering points	0261 79	P	N/A
EDMX <sup>3</sup> - multi-function measuring units	Legrand software dedicated to measurement - for 32 metering points	0261 88	P	N/A
EDMX <sup>3</sup> - multi-function measuring units	Legrand software dedicated to measurement - for unlimited number of metering points	0261 89	P	N/A
Current transformers CT	Single phase - for 16 x 12.5 mm bar and Ø 21 mm cable 1.25 VA output	0046 31	P	N/A
Current transformers CT	Single phase - for 16 x 12.5 mm bar and Ø 21 mm cable 2.5 VA output	0046 34	P	N/A
Current transformers CT	Single phase - for 16 x 12.5 mm bar and Ø 21 mm cable 5.5 VA output	0046 36	P	N/A
Current transformers	Single phase - for 40.5 x 10.5 mm bar and Ø 35 mm cable 400/5 12 VA output	0046 38	P	N/A
Current transformers CT	Single phase - for 127 x 38 mm bar 20 VA output	0046 45	P	N/A
Current transformers CT	Single phase - for 127 x 38 mm bar 15 VA output	0046 46	P	N/A
Current transformers CT	Single phase - for 127 x 54 mm bar 50 VA output	0046 48	P	N/A
Current transformers CT	Three phase current transformer - for three 20.5 x 5.5 mm bars 3 VA output	0046 98	P	N/A
Current transformers CT	Three phase current transformer - for three 30.5 x 5.5 mm bars 4 VA output	0046 99	P	N/A
Current transformers CT	Single phase current transformer - for 20.5 x 12.5 and 30 x 10.5 mm bar and Ø 23 mm cable 11 VA output	0047 75	P	N/A
Current transformers CT	Single phase current transformer - for 65 x 32 mm bar 12 VA output	0047 76	P	N/A
Current transformers CT	Single phase current transformer - for 65 x 32 mm bar 15 VA output	0047 77	P	N/A
Current transformers CT	Single phase current transformer - for 65 x 32 mm bar 20 VA output	0047 78	P	N/A
Current transformers CT	Single phase current transformer - for 84 x 34 mm bar 15 VA output	0047 79	P	N/A
Current transformers CT	Single phase current transformer - for 127 x 54 mm bar 50 VA output	0047 80	P	N/A
Changeover switches	Two way - 250 V	0043 82	4129 00	31
Changeover switches	Double two way - 400 V	0043 83	4129 01	31
Changeover switches	Two way with centre point - 250 V	0043 85	4129 02	31
Push buttons/control switches	Dual function + indicator - 1 NO + green indicator	0044 63	P	N/A
Push buttons/control switches	Dual function + indicator - 1 NC + red indicator	0044 64	P	N/A
Push buttons/control switches	Dual function + indicator - 1 NO + green indicator + 1 NC + red indicator	0044 68	P	N/A
Push buttons	Single function push button - 1 NO	0044 53	4129 08	45
Push buttons,	Single function push button - 1 NC	0044 54	4129 09	45
Control switches,	Single function control switch - 2 NO	0044 55	4129 10	45
Control switches	Single function control switch - 1 NO + NC	0044 58	4129 11	45
Indicators	Three phase voltage indicator	0031 43	P	N/A
Indicators	Indicator 250 V - single green	0044 83	4129 26	45
Indicators	Indicator 250 V - single red	0044 84	4129 27	45
Indicators	Indicator 250 V - single orange	0044 85	4129 28	45
Indicators	Indicator 250 V - single blue	0044 86	4129 29	45
Indicators	Indicator 250 V - single colourless	0044 87	4129 30	45
Indicators	Indicator 250 V - double green + red	0044 88	P	N/A
Indicators - accessories	Replacement lamps E10 - 1.2 W 8/12 V incandescent	0044 32	P	N/A
Indicators - accessories	Replacement lamps E10 - 1.2 W 24 V incandescent	0044 33	P	N/A
Indicators - accessories	Replacement lamps E10 - 1.2 W 230 V neon	0044 36	P	N/A
Indicators - accessories,	Replacement lamps E10 - 1.2 W 230 V fluo for blue and green diffusers	0044 37	P	N/A
Time switches	MicroRex D11 - 1 module	0037 00	0037 10	53
Time switches	Fixing accessory - support frame for surface mounting	0495 94	P	N/A

Status : P = Phase out

N/A = No direct replacement available. Please contact us on +44 (0) 370 608 9020.



Trunking lengths available with aluminium or copper conductors

Self-shearing bolts ensure the correct torque is applied at the joint

# ZUCCHINI SCP

Compact design combined with powerful performance makes Zucchini SCP the intelligent choice for demanding installations

SCP busbar trunking systems are ideal for the distribution of high power in industrial, commercial and service sector installations. Flexible and safe, SCP is continually developed to offer maximum versatility in multiple environments.

The high power, super compact busbar range provides a complete solution whether connecting transformers to the main panel board, or transporting and distributing power around the building, including rising mains applications.



## Green T.HE high efficiency transformers

quality through to the core



Legrand transformers are renowned for quality. Manufactured within a state-of-the-art production facility with attention to detail being paramount, each transformer undergoes rigorous testing prior to despatch.

Legrand has many years experience in the production of dry transformers cast under vacuum in epoxy resin up to 36 kV. The 'GreenT.HE' range of high efficiency transformers conforms to IEC 60076-11 and EU regulation 548/2014.



To find out more call our technical support team on +44 (0) 370 608 9020

## CONTACT DETAILS

### Quotations and Technical Support:

Legrand Electric Ltd.  
Great King Street North,  
Birmingham, B19 2LF  
Tel: +44 (0) 370 608 9020  
E-mail: powersales.uk@legrand.co.uk

### Customer Services:

Legrand Electric Ltd.  
Dial Lane, West Bromwich,  
B70 0EB  
Tel: +44 (0) 345 605 4333  
E-mail: legrand.sales@legrand.co.uk

### Republic of Ireland:

Tel: 01 295 9673  
E-mail: legrand.sales@legrand.co.uk



FOLLOW  
US AT



[www.legrand.co.uk](http://www.legrand.co.uk)  
[www.legrand.ie](http://www.legrand.ie)



[www.youtube.com/legrandtvuk](https://www.youtube.com/legrandtvuk)



[www.voltimum.co.uk](http://www.voltimum.co.uk)  
[www.voltimum.ie](http://www.voltimum.ie)



[www.twitter.com/legranduk](https://www.twitter.com/legranduk)



[www.linkedin.com/  
company/legranduk](https://www.linkedin.com/company/legranduk)



### Head office (UK and Ireland):

Legrand Electric Limited  
Great King Street North, Birmingham, B19 2LF  
Tel: +44 (0) 370 608 9000  
Website: [www.legrand.co.uk](http://www.legrand.co.uk)

In accordance with its policy of continuous improvement, the Company reserves the right to change specifications and designs without notice. All illustrations, descriptions, dimensions and weights in this catalogue are for guidance and cannot be held binding on the Company. All contents and design presentation included in this publication are © Legrand Electric Limited. All rights reserved. 2020



This document is printed on sustainably sourced paper. Please recycle.

The Legrand logo is a registered trademark of the Legrand group of companies.