

modular DIN rail equipment

dimensions

■ Dimensions

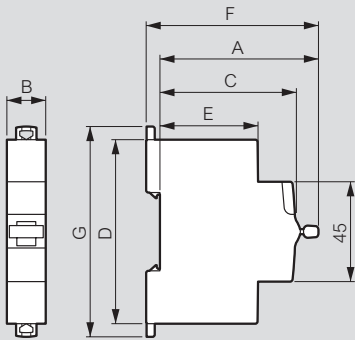

Description	Dimension (mm)										
	A	B				C	D	E	F	G	
		1P	1P+N	2P	3P	4P					
CX ³ Push buttons/ control switches	68	17.7				60	83	44	74	94	
CX ³ contactors up to 25 A	66.3/ 61	17.8	-	17.8	35.6	35.6	61	84.5	44	72.6/ 67.3	94.8
CX ³ contactors 40 A & 63 A	62	-	-	35.6	53.4	53.4	60	83	44	68	94
Auxiliaries for CX ³ contactors	61	9 / 17.8				61	84.5	44	67	84.5	
CX ³ LED indicators	61	17.8	-			61	84.5	44.8	67.3	94.9	

■ Dimensions

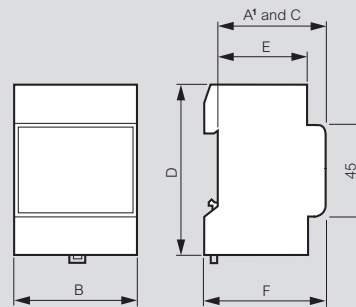

Description		Dimension (mm)					
		A'	B	C	D	E	F
Transformers	Cat. Nos. 4130 90/91	60	36	60	84	44	66
	Cat. No. 4130 93	60	72	60	84	44	66
	Cat. Nos. 4130 95/96	60	72	60	84	44	66
	Cat. Nos. 4130 97/98	60	89	60	95	44	66

1 : Maximum projection