

CR1292

1 GANG 2 MODULE ANGLED KEYSTONE PLATE



Instinct™
WIRING ACCESSORIES

CONSTRUCTION

Product Category	Wiring Accessory
Product Group	Data & Communication
Product Type	Keystone System
Shape	Square Plate
Material	Urea Formaldehyde
Finish	Moulded
Mounting Type	Flush/Surface Keystone Modular System

POWER

Current	Not Applicable
Current Type	Not Applicable
Frequency	Not Applicable
Input Voltage	Not Applicable
Switched Poles	Not Applicable
Number of Rocker Switches	0
Number of Ways	Not Applicable
Fuse Rating	Not Applicable

AESTHETICS

Plate Gang / Module Size	1 Gang
Plate Colour	White
Rocker Colour	Not Applicable
Light Reflectance Value (LRV)	74
Printing Text/Type	Not Applicable
Status Indicator	N
Switched Outlets	N
Part M Compliance	Y
Anti Microbial Properties	Y
Key Features & Benefits	Curved Slimline Plate 45° Angled Outlet Minimises Cable Bend Radius

TERMINAL

L & N Terminal Capacity as per BS Standard	Not Applicable
Earth Terminal Capacity as per BS Standard	Not Applicable
Number of Earth Terminals	0
Cable Strip Length	Not Applicable
Screwdriver Type Required	Not Applicable
Torque requirement as per BS Standard L&N	Not Applicable
Torque requirement as per BS Standard Earth	Not Applicable

LOCATION

Max Ambient Operating Temp as per BS Req.	Not Applicable
Min Ambient Operating Temp as per BS Req.	Not Applicable
Max Altitude as per BS Requirement	2000m
IP Rating	Not Applicable

DIMENSIONAL / FIXING

Height	86mm
Width	86mm
Depth Overall	25mm
Depth Interior only	17.5mm
Gross Weight	0.044kg
Minimum Back Box Depth	Not Applicable
Suggested Back Box Depth	Not Applicable
Fixing Centres	60.3mm
Minimum Access Top	100cm
Minimum Access Bottom	100cm
Minimum Access Left	100cm
Minimum Access Right	100cm
Minimum Access Front	100cm
Minimum Access Rear	100cm
Flush Mounting Metal Box	SB615 (35mm)
Flush Mounting Dry Lining Box	SB619 (35mm)
Surface Mounting Box	9041 (44mm)

STANDARDS

British Standard/s	BS 5733
Other Markings/Standards	CE

PACKAGING

Inner Carton Qty	10
Customer MOQ	10

SUSTAINABILITY

URL to technology list	https://www.crabtreecommercial.co.uk/
------------------------	---

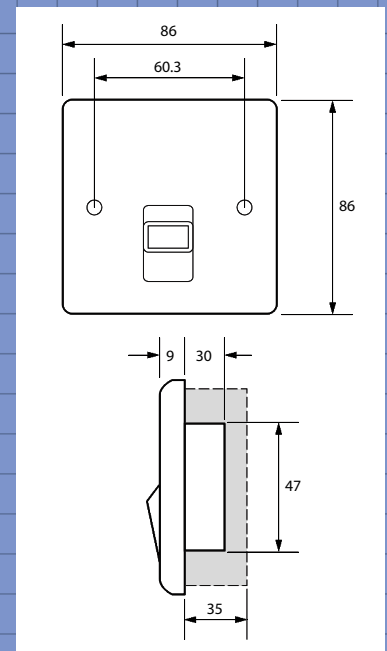

Electrium Sales Limited
A Siemens Company
Tel: +44 (0) 1543 438310
Fax: +44 (0) 1543 000000
Email: crabtree.technical@electrium.co.uk
www.electrium.co.uk

Although every effort has been made to ensure accuracy in the compilation of the technical detail within this publication, specifications and performance data are constantly changing. Latest details can be obtained from Crabtree.

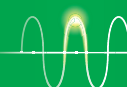

Crabtree