

# CR1014/FF

## 20A DP SWITCH WITH LED PRINTED FRIDGE FREEZER



**Instinct™**  
WIRING ACCESSORIES

### CONSTRUCTION

Product Category  
Product Group  
Product Type  
Shape  
Material  
Finish  
Mounting Type

Wiring Accessory  
Power & Control  
Plate Switch  
Square Plate  
Urea Formaldehyde  
Moulded  
Flush/Surface

### POWER

Current  
Current Type  
Frequency  
Input Voltage  
Switched Poles  
Number of Rocker Switches  
Number of Ways  
Fuse Rating

20 Amps  
AC  
50Hz  
250V  
Double Pole  
1  
1  
Not Applicable

### AESTHETICS

Plate Gang / Module Size  
Plate Colour  
Rocker Colour  
Light Reflectance Value (LRV)  
Printing Text/Type  
Status Indicator  
Switched Outlets  
Part M Compliance  
Anti Microbial Properties  
Key Features & Benefits

1 Gang  
White  
White  
74  
Fridge Freezer, Laser Printed  
Y  
N  
Y  
Y  
Curved Slimline Plate  
All Upward Facing Terminals  
Full Contact Cable Clamp  
Integrated LED Light Indicator  
Fully Rated to 20A

### TERMINAL

L & N Terminal Capacity as per BS Standard  
Earth Terminal Capacity as per BS Standard  
Number of Earth Terminals  
Cable Strip Length  
Screwdriver Type Required  
Torque requirement as per BS Standard L&N  
Torque requirement as per BS Standard Earth

3 x 2.5mm<sup>2</sup>, 2 x 4.0mm<sup>2</sup>, 1 x 6.0mm<sup>2</sup>  
3 x 2.5mm<sup>2</sup>, 2 x 4.0mm<sup>2</sup>, 1 x 6.0mm<sup>2</sup>  
2  
10mm  
Slotted Type  
0.8Nm  
0.8Nm

### LOCATION

Max Ambient Operating Temp as per BS Req.  
Min Ambient Operating Temp as per BS Req.  
Max Altitude as per BS Requirement  
IP Rating

Occasionally reaching +35°C  
Not exceeding +25°C  
2000m  
IP2X

### DIMENSIONAL / FIXING

Height  
Width  
Depth Overall (Inc Rocker)  
Depth Interior only  
Gross Weight  
Minimum Back Box Depth  
Suggested Back Box Depth  
Fixing Centres  
Minimum Access Top  
Minimum Access Bottom  
Minimum Access Left  
Minimum Access Right  
Minimum Access Front  
Minimum Access Rear  
Flush Mounting Metal Box  
Flush Mounting Dry Lining Box  
Surface Mounting Box

86mm  
86mm  
25mm  
15mm  
0.08kg  
25mm  
25mm  
60.3mm  
100cm  
100cm  
100cm  
100cm  
100cm  
100cm  
SB655 (25mm) or CR2201/BG (40mm)  
SB619 (35mm)  
9047 (25mm)

### STANDARDS

British Standard/s  
Other Markings/Standards

BS EN 60669-1  
CE

### PACKAGING

Inner Carton Qty  
Customer MOQ

10  
10

### SUSTAINABILITY

URL to technology list

<https://www.crabtreecommercial.co.uk/>

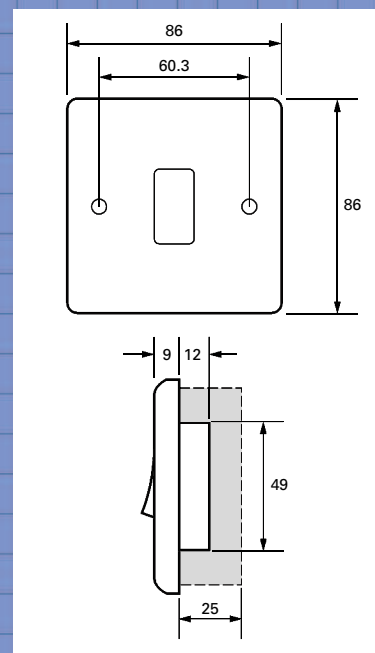

Electrium Sales Limited  
A Siemens Company  
Tel: +44 (0) 1543 438310  
Fax: +44 (0) 1543 000000  
Email: [crabtree.technical@electrium.co.uk](mailto:crabtree.technical@electrium.co.uk)  
[www.electrium.co.uk](http://www.electrium.co.uk)

Although every effort has been made to ensure accuracy in the compilation of the technical detail within this publication, specifications and performance data are constantly changing. Latest details can be obtained from Crabtree.

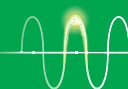

**Crabtree**