

CR1009

10A ISOLATOR SWITCH WITH
ISOLATOR SYMBOL



Instinct™
WIRING ACCESSORIES

CONSTRUCTION

Product Category
Product Group
Product Type
Shape
Material
Finish
Mounting Type

Wiring Accessory
Power & Control
Plate Switch
Square Plate
Urea Formaldehyde
Moulded
Flush/Surface

POWER

Current
Current Type
Frequency
Input Voltage
Switched Poles
Number of Rocker Switches
Number of Ways
Fuse Rating

10 Amps
AC
50Hz
250V
Triple Pole
1
1
Not Applicable

AESTHETICS

Plate Gang / Module Size
Plate Colour
Rocker Colour
Light Reflectance Value (LRV)
Printing Text/Type
Status Indicator
Switched Outlets
Part M Compliance
Anti Microbial Properties
Key Features & Benefits

1 Gang
White
White
74
Isolator Symbol, Laser Printed
N
N
Y
Y
Curved Slimline Plate
All Upward Facing Terminals
Full Contact Cable Clamp
Fully Rated to 10A

TERMINAL

L & N Terminal Capacity as per BS Standard
Earth Terminal Capacity as per BS Standard
Number of Earth Terminals
Cable Strip Length
Screwdriver Type Required
Torque requirement as per BS Standard L&N
Torque requirement as per BS Standard Earth

4 x 1.0mm², 3 x 1.5mm², 1 x 2.5mm²
Not Applicable
0
10mm
Slotted Type
2.5Nm
Not Applicable

LOCATION

Max Ambient Operating Temp as per BS Req.
Min Ambient Operating Temp as per BS Req.
Max Altitude as per BS Requirement
IP Rating

Occasionally reaching +35°C
Not exceeding +25°C
2000m
IP2X

DIMENSIONAL / FIXING

Height
Width
Depth Overall (Inc Rocker)
Depth Interior only
Gross Weight
Minimum Back Box Depth
Suggested Back Box Depth
Fixing Centres
Minimum Access Top
Minimum Access Bottom
Minimum Access Left
Minimum Access Right
Minimum Access Front
Minimum Access Rear
Flush Mounting Metal Box
Flush Mounting Dry Lining Box
Surface Mounting Box

86mm
86mm
23mm
15mm
0.07kg
25mm
25mm
60.3mm
100cm
100cm
100cm
100cm
100cm
100cm
SB655 (25mm) or CR2201/BG (40mm)
SB619 (35mm)
9047 (25mm)

STANDARDS

British Standard/s
Other Markings/Standards

BS EN 60669-2-4
CE

PACKAGING

Inner Carton Qty
Customer MOQ

10
10

SUSTAINABILITY

URL to technology list

<https://www.crabtreecommercial.co.uk/>

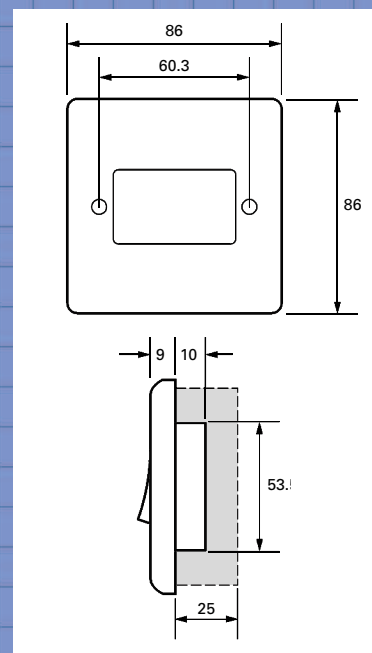

Electrium Sales Limited
A Siemens Company
Tel: +44 (0) 1543 438310
Fax: +44 (0) 1543 000000
Email: crabtree.technical@electrium.co.uk
www.electrium.co.uk

Although every effort has been made to ensure accuracy in the compilation of the technical detail within this publication, specifications and performance data are constantly changing. Latest details can be obtained from Crabtree.



Crabtree