

- Switch 5 ports Gigabit
  - Gigabit-switch 5 poorten
  - 5-port Gigabit switch
  - 5-Port Gigabit Switch
  - Switch 5 puertos Gigabit
- 4 130 09

- Comutador 5 portas Gigabit
- Διακόπτης Gigabit 5 θυρών
- Switch 5 πορτών Gigabit
- 5 portlu Gigabit Ağ Anahtarı
- مبدل ب 5 منافذ جيغا بايت/ثانية

- 5 口千兆开关
- Switch 5 porte Gigabit
- Switch 5 portów Gigabit
- 5 portos Gigabit switch

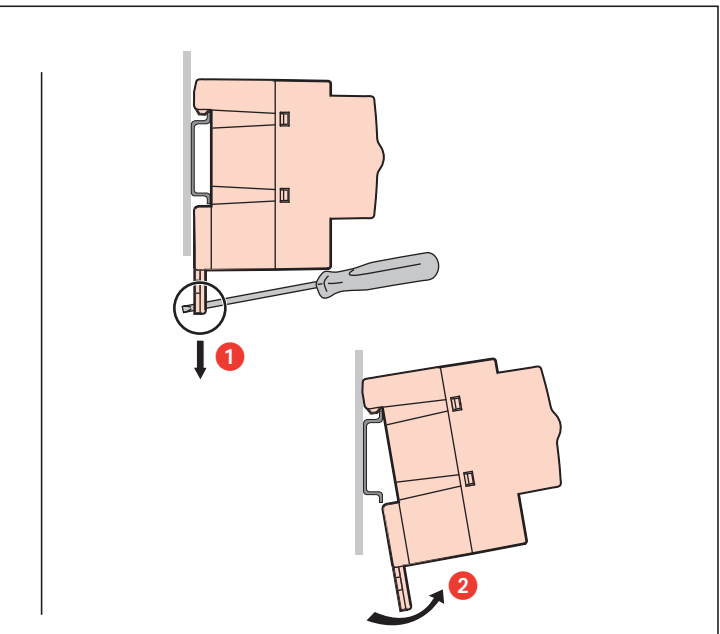
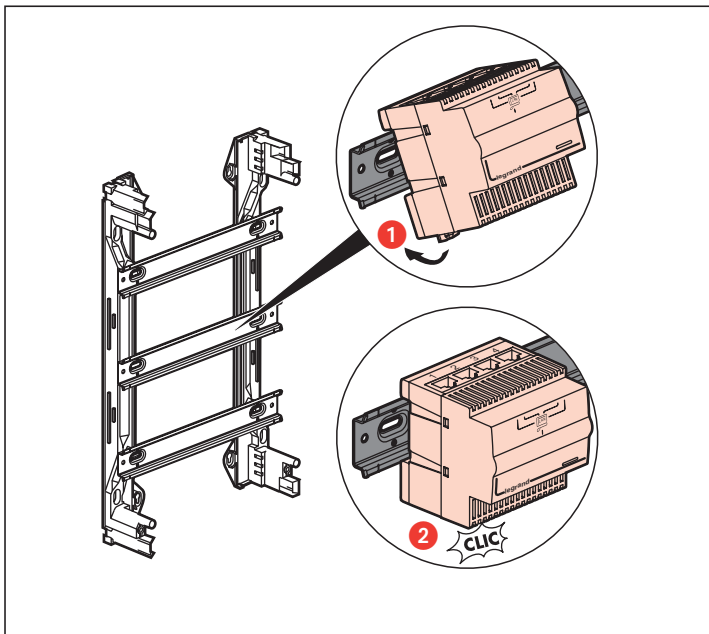
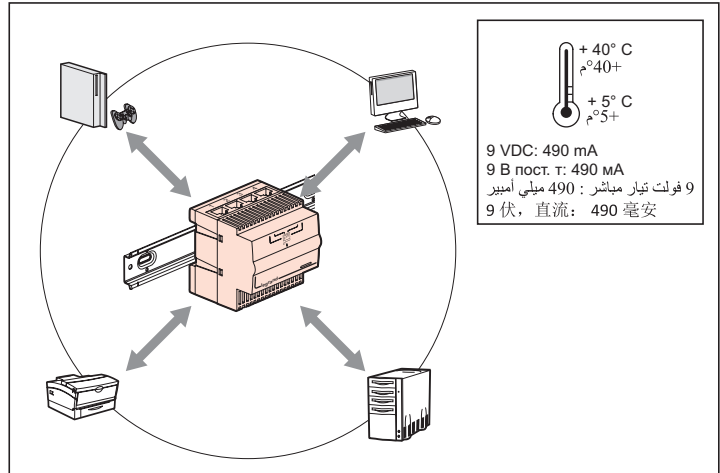
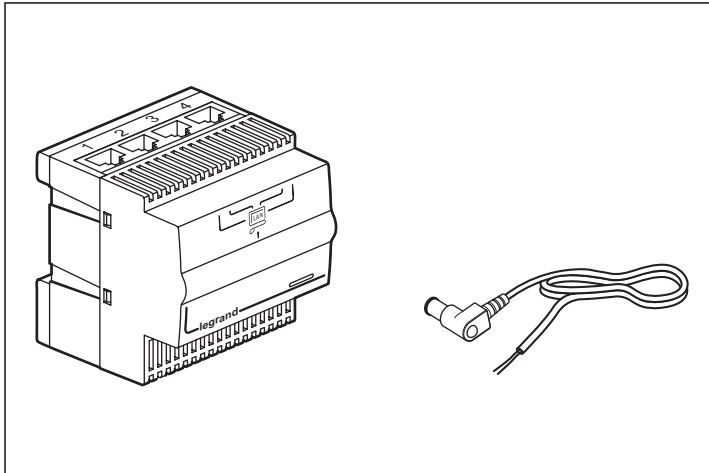

- Alimentation
- Voeding
- Power supply
- Stromspeisung
- Alimentación
- Alimentação
- Τροφοδοσία
- Питание
- Besleme
- موصول الطاقة
- 供电
- Alimentazione
- Zasilanie
- Áramellátás

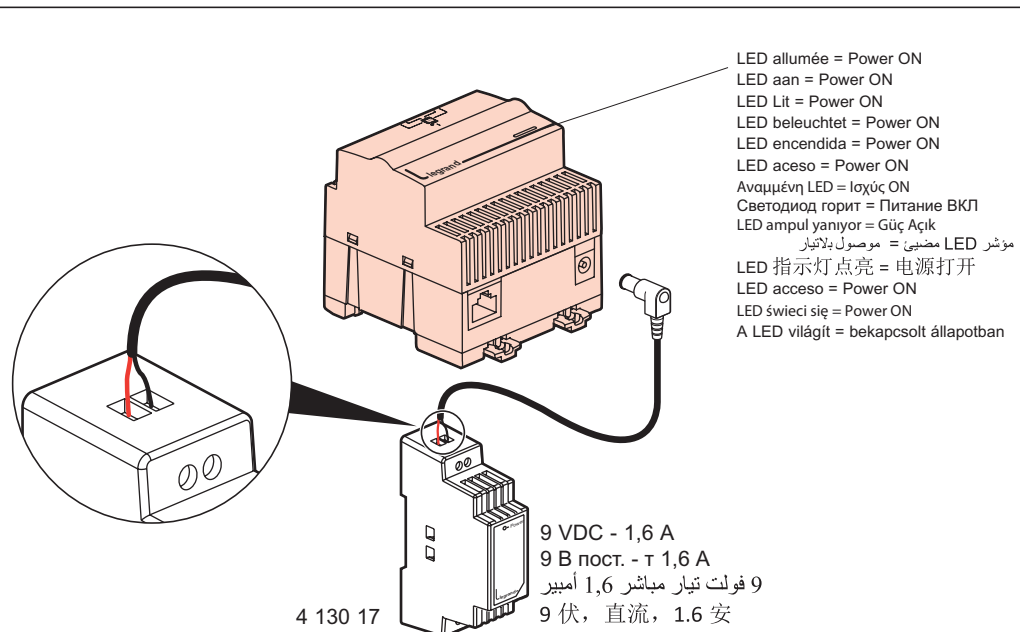

4 130 17

LE03758AB

- Liaison entre 2 switches
- Verbinding tussen 2 switches
- Link between 2 switches
- Verbindung zwischen zwei Switches
- Conexión entre 2 switches
- Ligaçao entre 2 computadores
- Σύνδεση ανάμεσα σε 2 διακόπτες

- Соединение 2-х switches
- 2 anahtar ara bağlantısı
- وصلة بين بدالتين
- 2 个开关间的连接
- Collegamento tra 2 switch switchami
- Połączenie między 2 switchami
- Kapcsolat 2 switch között

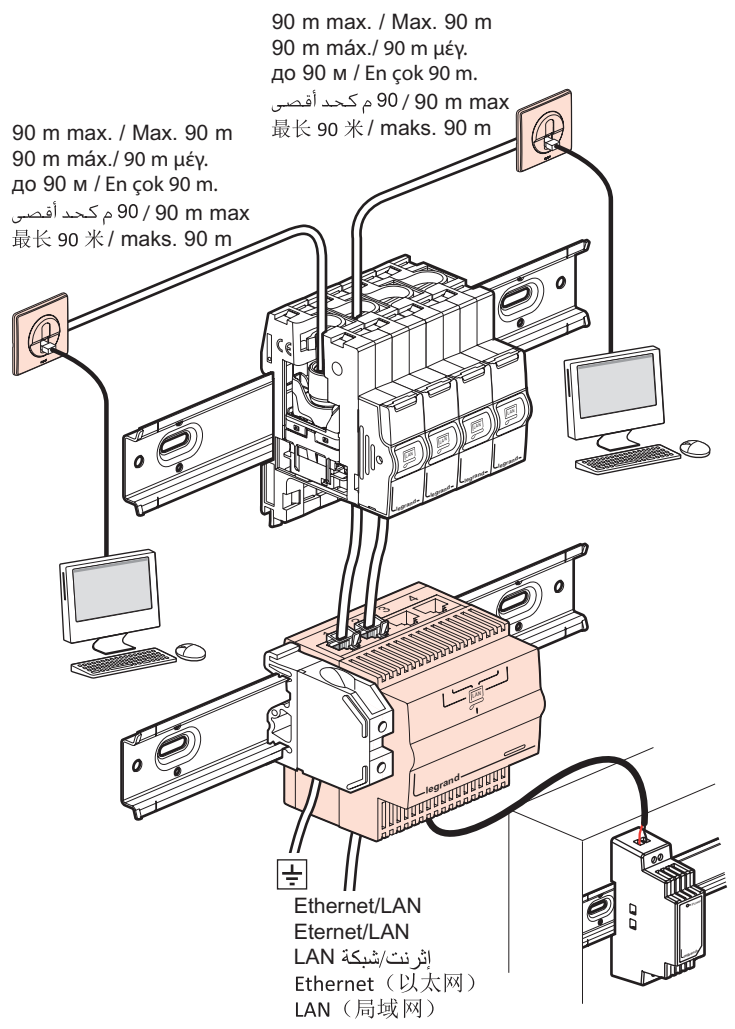
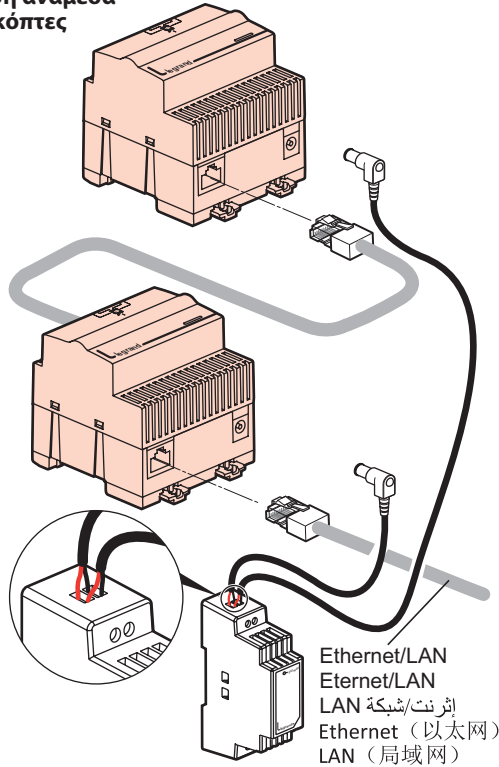

This symbol indicates that in order to prevent any negative effects on the environment and on people, this product should be disposed of separately from other household waste, by taking it to authorised collection centres, in accordance with the EU countries local waste disposal legislations. Disposing of the product without following local regulations may be punished by law. It is recommended that you check that in your country this product is subject to WEEE legislations.

#### ⚠ Consignes de sécurité

Avant toute intervention, couper le courant.  
Respecter strictement les conditions d'installation et d'utilisation.

#### ⚠ Veiligheidsinstructies

Sluit de stroom af voordat u aan de slag gaat.  
Neem zorgvuldig de installatie- en gebruikvoorwaarden in acht.

#### ⚠ Safety instructions

Make sure the power supply is disconnected before any intervention.  
Strictly comply with instructions for installation and use.

#### ⚠ Sicherheitshinweise

Vor jeglichem Eingriff die Spannungsfreiheit sicherstellen.  
Einbau- und Gebrauchsanleitungen sind genau zu beachten.

#### ⚠ Consignas de seguridad

Antes de realizar cualquier intervención, cortar la corriente eléctrica.  
Respetar estrictamente las condiciones de instalación y uso.

#### ⚠ Instruções de segurança

Antes de qualquer intervenção, cortar a corrente.  
Respeitar estritamente as condições de instalação e de utilização.

#### ⚠ Οδηγίες ασφαλείας

Πριν από κάθε παρέμβαση, διακόψτε την παροχή ρεύματος.  
Τηρήστε αυστηρά τις συνθήκες εγκατάστασης και χρήσης.

#### ⚠ Меры предосторожности

Отключить питание перед проведением любых ремонтных работ.  
Строго соблюдайте требования к условиям монтажа и эксплуатации.

(FR) (LU) (BE)

#### ⚠ Güvenlik talimatları

Her türlü müdahale öncesinde, elektrik akımını kesiniz.  
Kurulum ve kullanım koşullarına kesinlikle uyunuz.

(TR) (CY)

(NL) (BE)

#### ⚠ إرشادات الأمان:

"اقطع التيار الكهربائي، قبل أي تدخل. تقيداً تماماً بشروط التثبيت والاستخدام."

(GB) (IE)

#### ⚠ 安全警示

在进行任何作业前，请切断电源。  
请严格遵守相关安装和使用条件的要求。

(DE)

#### ⚠ Istruzioni di sicurezza

Prima di effettuare qualsiasi intervento, togliere la corrente.  
Rispettare scrupolosamente le condizioni di installazione e d'uso.

(IT) (CH)

(ES)

#### ⚠ Zalecenia bezpieczeństwa

Przed przystąpieniem do prac należy odłączyć zasilanie.  
Ścisłe przestrzegać warunków instalacji i użytkowania.

(PL)

(PT)

#### ⚠ Biztonsági előírások

Bármilyen beavatkozás előtt szakítsa meg az áramellátást.  
A beszerelési és használati előírásokat szigorúan be kell tartani.

(HU)

(GR) (CY)

(RU)