

Controller - 4 DALI outputs

Catalogue number(s): 488 44

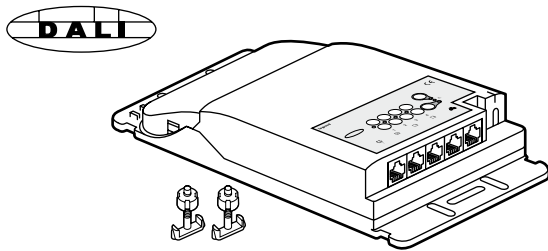

CONTENTS

Page

1. Use	1
2. Technical features	1
3. Overall dimensions	2
4. Connection	2
5. Installation	2
6. Parameter setting	3
7. Maintenance	3
8. Standards	3

1. USE

This device is a power unit used for managing lighting loads (DALI or DSI).

It must be connected to one or more detectors and/or diverted auxiliary controls in order to operate.

The load(s) can be controlled manually or automatically by the detectors and/or the controls associated with the device.

2. TECHNICAL FEATURES

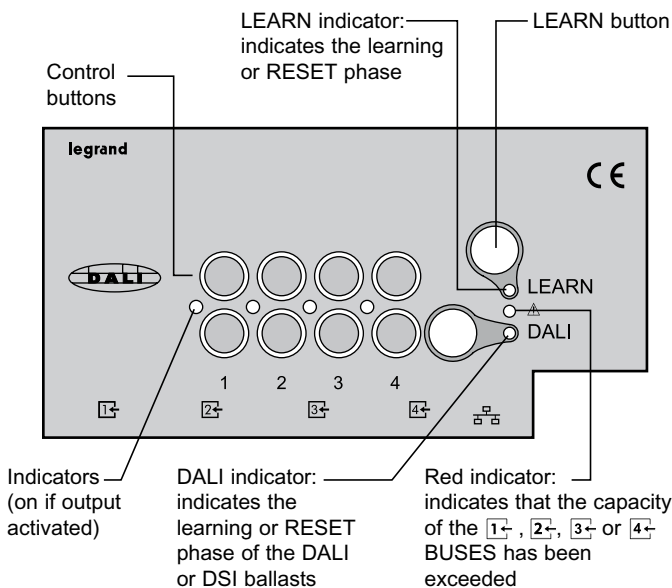

① DALI Ballast

①	
230 V~	32 ballasts max./channel
110 V~	

Voltage: 100-240 V~

Frequency: 50/60 Hz

No load power consumption: 2.4 W

Wiring:

- Power:

Power supply: 2 x 2.5 mm² (screw terminals)

DALI ≤ 1.5 mm²

- Control:

Connection between detector and controller: RJ 45 cord or cable or BUS/SCS cable to be fitted with RJ 45 connector

(1-, 2-, 3-, 4- 150 m max. cord or BUS/SCS cable between the controller and the furthest detector)

(5-500 m max. cord or BUS/SCS cable between the power supply and the furthest product)

The product incorporates positive safety

- If there is a peripheral fault on the 1-, 2-, 3- or 4- BUS, the lights come back on automatically after 10 minutes.

- If there is a connection fault on the 5-500 BUS, the lights come back on automatically after 50 seconds.

Product installation: in a suspended ceiling or on a suitable cable tray

Peripherals compatible with the offer:

- Digital detectors: infrared, ultrasound or dual technology

- Pushbutton lighting controls: switch and scenario management multifunction controls

⚠ 1- + 2- + 3- + 4- ≤ 200 mA

Usage temperature: -5°C to +45°C

Storage temperature: -20°C to +70°C

Weight: 525 g

Impact resistance: IK04

Penetration by solid and liquid matter: IP20

3. OVERALL DIMENSIONS

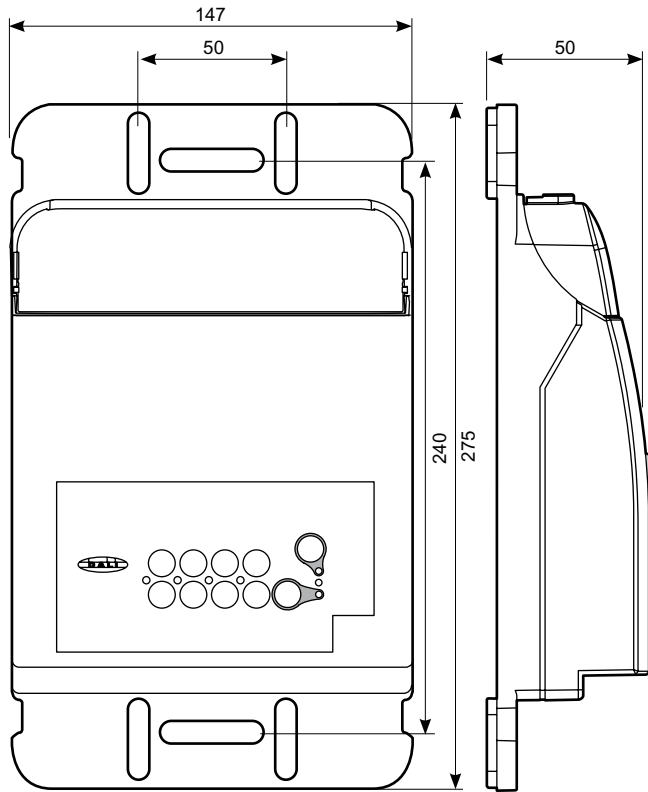

4. CONNECTION

All the wiring must be carried out with the mains power off.

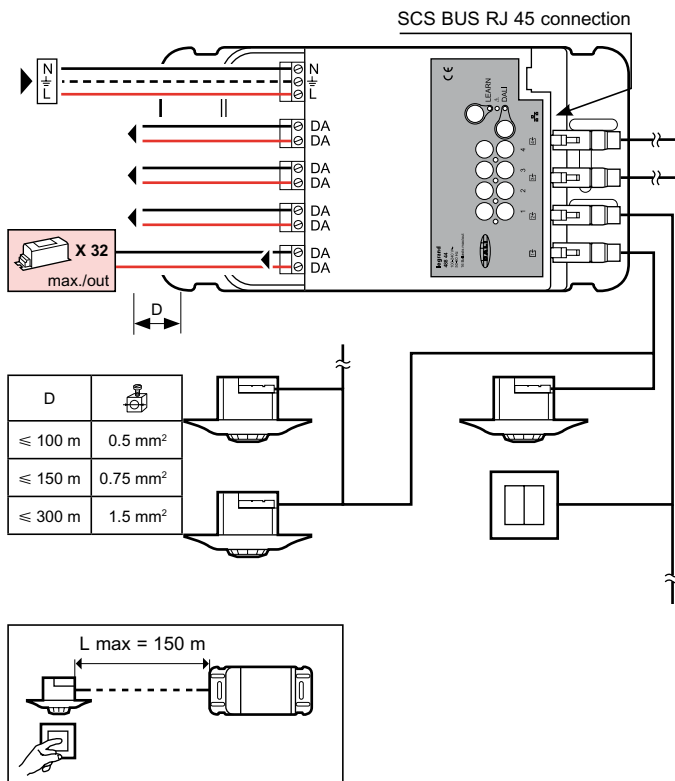

5. INSTALLATION

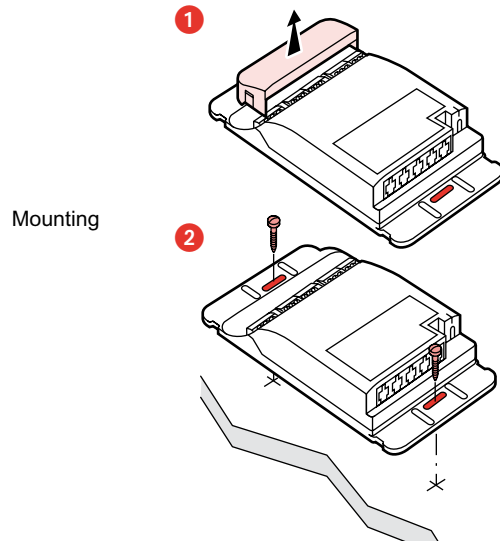

On cable tray

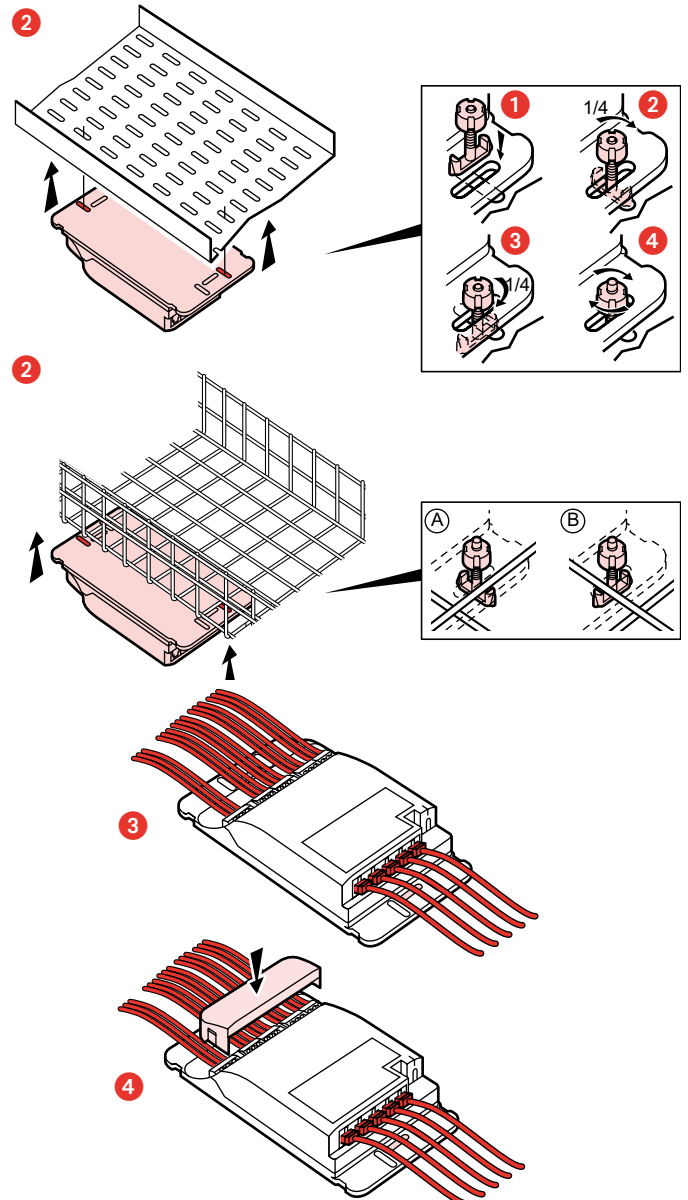

6. PARAMETER SETTING

NB: All the wiring must be carried out with the mains power off.

Switching the controller on generates an automatic configuration: the compatible peripheral(s) and the controller recognise one other on their 1, 2, 3 and 4 BUSES.

The parameters of the installation can be set using configuration tools Cat. No. 882 35 or Cat. No. 882 30.

Consult the relevant technical data sheets for detailed parameter setting of digital detectors that are compatible with the offer.

NB:

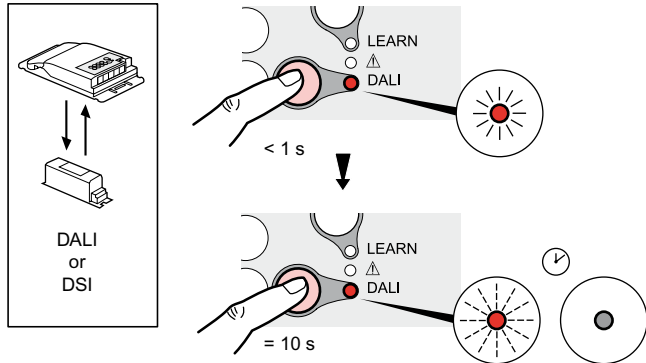

DALI Ballast: total lighting of all loads, then gradual dimming and switching off of the loads in a random order.

NOTE: Do not install DSI and DALI ballasts on the same channel.

Note: All technical information is available at



7. MAINTENANCE

Do not use: acetone, tar-removing cleaning agents or trichloroethylene.

- Maintenance with the following products:
- Hexane (En 60669-1)
 - Methylated spirit
 - Soapy water
 - Diluted ammonia
 - Bleach diluted to 10%
 - Window-cleaning products

ATTENTION: An initial test is required for the use of other special maintenance products.

8. STANDARDS

Directive: CE

Installation standards: NFC 15-100

Product standards: IEC 60669-2-1

Environmental standards:

- EU Directive 2002/96/EC: WEEE (Waste Electrical and Electronic Equipment)

- EU Directive 2002/95/EC:

RoHS (Restriction of Hazardous Substances)

- Regulations: ERP (public buildings)

ERT (workplace buildings)

IGH (high-rise buildings)