

**⚠ Safety notes**

This product should be installed in line with installation rules, preferably by a qualified electrician. Incorrect installation and use can lead to risk of electric shock or fire. Before carrying out the installation read the instructions and take account of the product's specific mounting location. Do not open up, dismantle, alter or modify the device except where specifically required to do so by the instructions. All Legrand products must be opened and repaired exclusively by personnel trained and approved by Legrand. Any unauthorised opening or repair completely cancels all liabilities and the rights to replacement and guarantees. Use only Legrand brand accessories.

The device contains a LiMnO<sub>2</sub> primary cell. When the product reaches the end of its life, this cell must be correctly removed and disposed of in accordance with national legislation and the requirements of environmental protection.

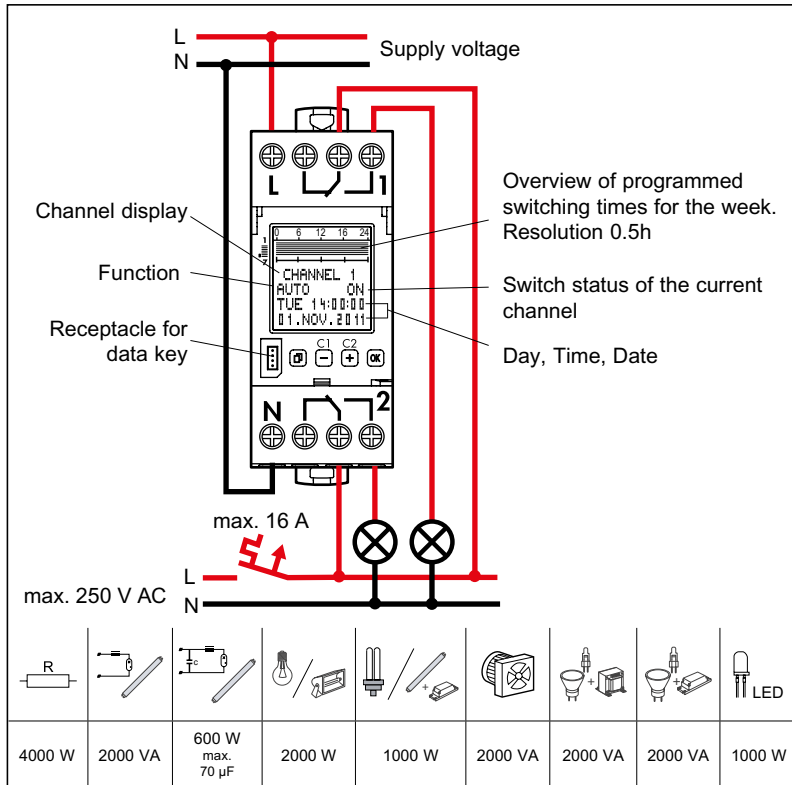

Operating principle: Typ 1.B. S. T.  
 IEC/EN 60730-1, IEC/EN 60730-2-7  
 Operation in a normal environment  
 Montage: in distribution panel, Degree of contamination: 2  
 Switch output, potential-free  
 Rated impulse voltage: 4 kV

**General information**

- Start-up: after applying the supply voltage, the time switch starts automatically with the last selected function. The relay position is set by the current program.
- Battery backup
  - Backlighting not active
  - Data key READ/WRITE only via the menu
- For safety, when the time switch is connected to the mains supply the contact should not be used on an isolated low voltage supply and when the time switch is connected to the isolated voltage supply the contact should not be used on the mains supply.

- Select menu, back to main menu, Hold down > 1s = operating display
- Confirm selection or load parameters
- Select menu options or set parameters
- Channel selection

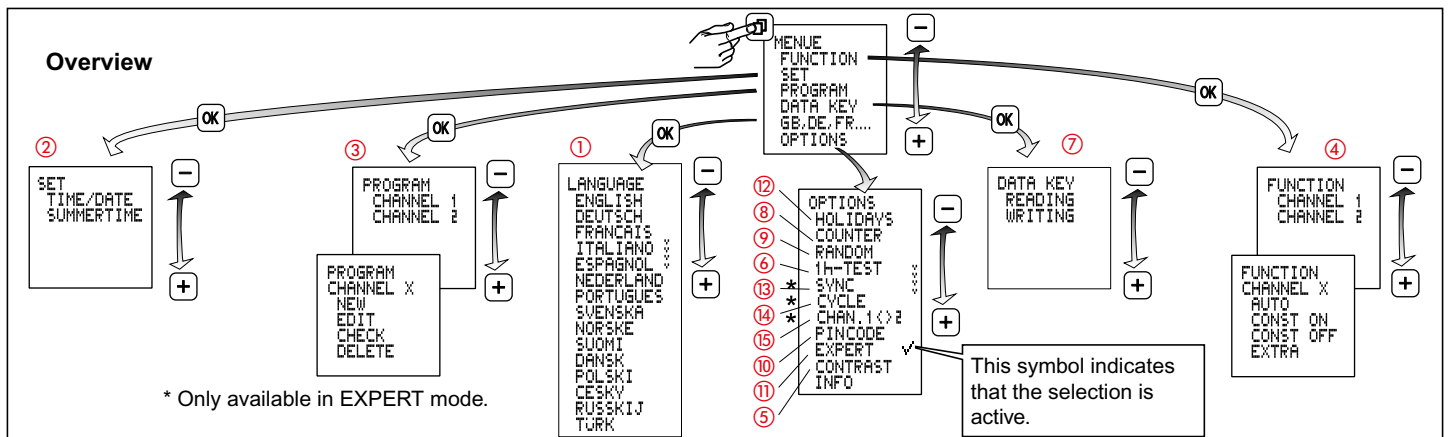

Technical data	4126 41	4126 42	4126 43
	047 71	6047 70	6047 72
Supply voltage:	230V 50/60Hz	120V 50/60Hz	24V AC/DC
Consumption :	ca. 1,5 W		
Contact rating:	2 changeover contact 16A 250V~μ cos φ = 1		
Parallel compensation	600W max. 70µF		
Accuracy :	~ 0,1 s /day		
Terminal capacity:	single strand	multi strand	
Programmes:	1,5...4 mm <sup>2</sup>	1,5...2,5 mm <sup>2</sup>	
Battery reserve:	28 per channel		
Storage ambient:	5 years		
Working ambient:	-20°C to +60°C		
IP:	-20°C to +55°C		
	20		

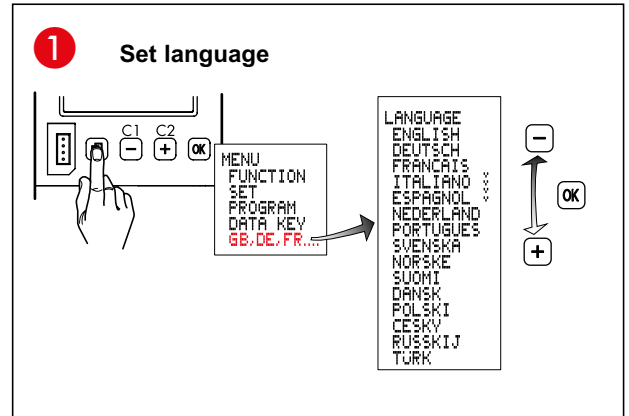

## 2 Set time/date, summertime/wintertime

**Summertime:** ± 1 hour

**Europe:** Factory set

**SPECIAL:** The switchover to/from summertime can be freely programmed by entering a start date and end date and is then executed each year on the same day of the week, e.g. Sunday

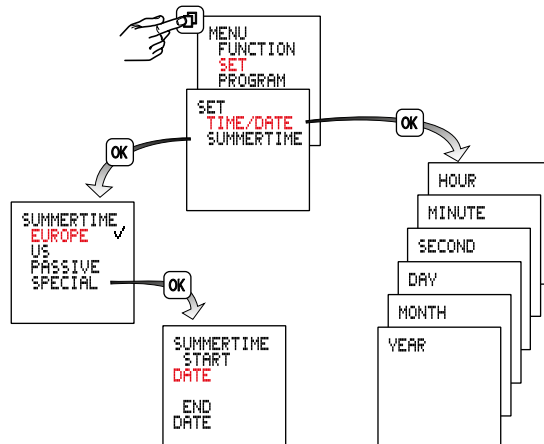

## 3 Programming

A program consists of an ON time, OFF time and associated on and off days.

Programs with predefined on/off days (Mon to Sun, Mon to Fri and Sat and Sun): for these programs, you only need to set the switching times. With the „INDIVIDUAL” option, you can allocate switching times to specific days of your choice.

The programs of a channel are combined with a logical OR.

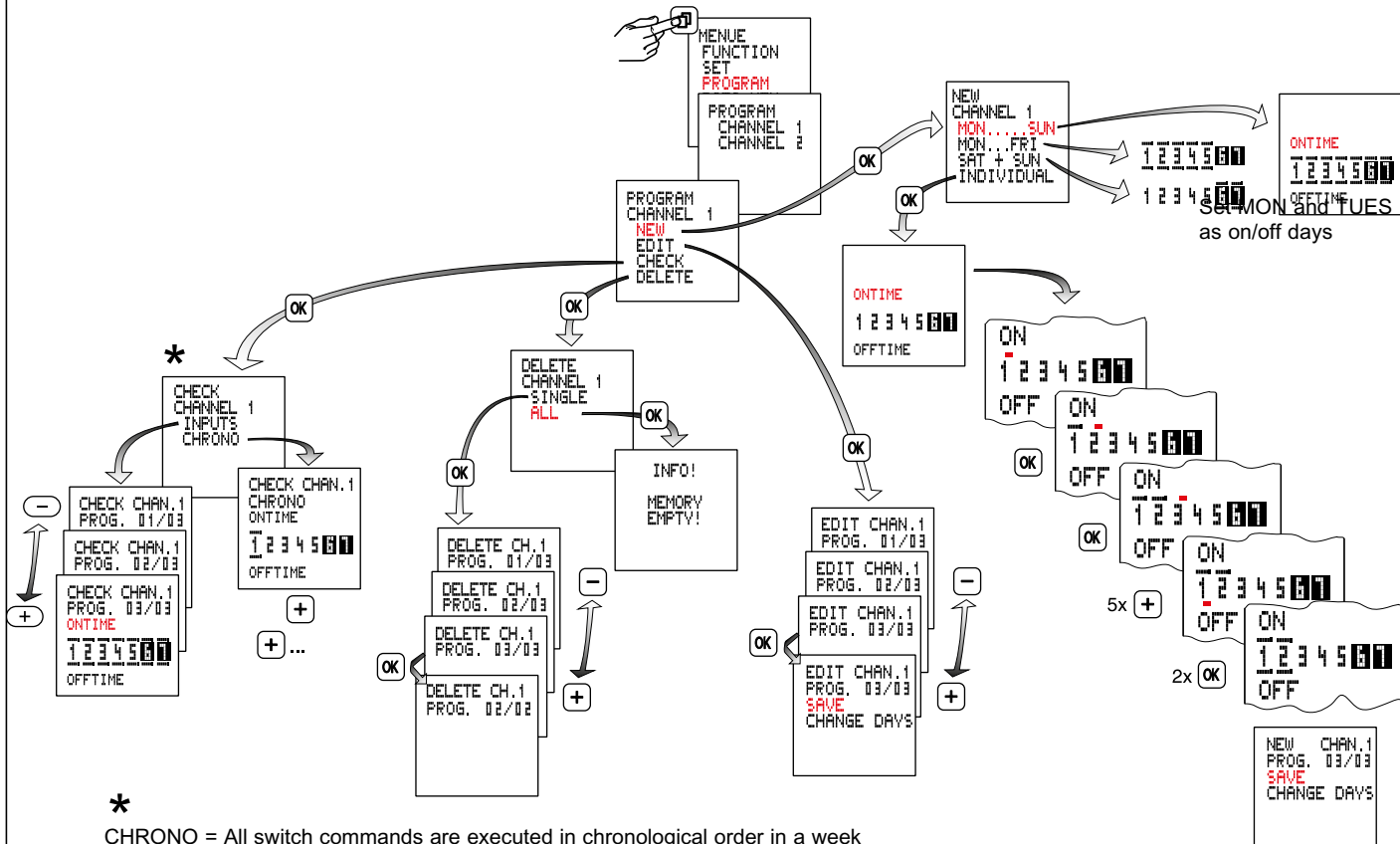

## 4 Modes

- **Auto** - Automatic operation
- **Constant ON**
- **Constant OFF**
- **Extra**

The switch status imposed by the program is inverted (manual override). With the next effective switch command, the time switch resumes control of on/off switching.

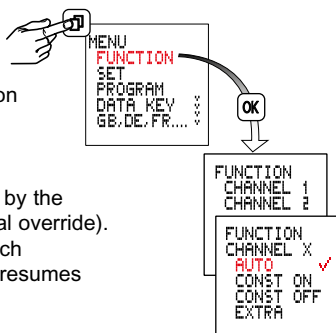

## Reset

### Warning!

The memory will be cleared, and all set data will be lost.

Hold down **OK** for more than 3 seconds and at the same time press and release **☐ - +**. The language, time, date, summertime/wintertime and switching times will have to be reentered.

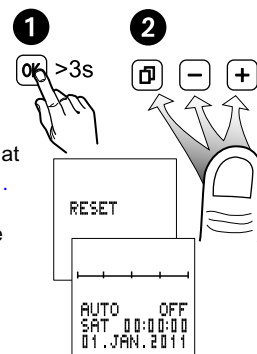

## 5 Contrast adjustment

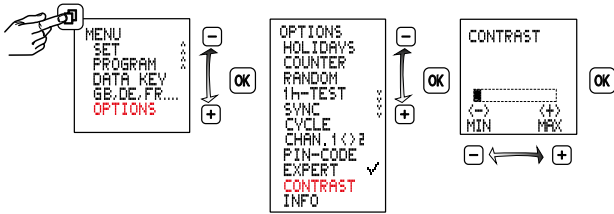

## 6 1 h-Test

When this function is activated, the outputs are switched on for one hour.

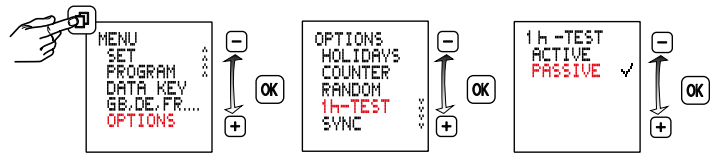

After one hour, the time switch returns automatically to the programmed mode.

## 7 Data key

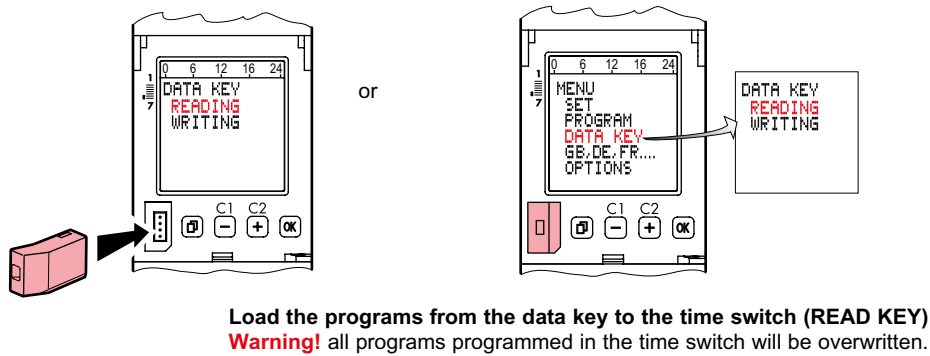
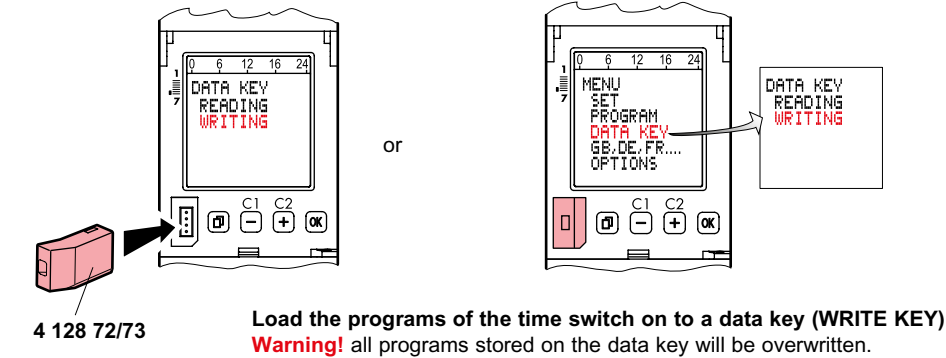

## 8 Hour counter

Displays the total relay ON time, (0 to 65535 h) and the date of the last reset.

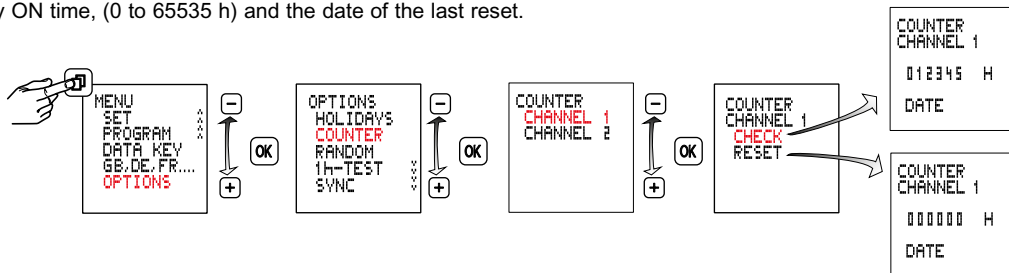

## 9 Random function

Function to simulate presence.

Function active: the programmed switching cycles are shifted at random within the range of  $\pm 15$  minutes.

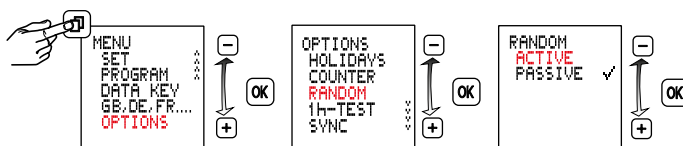

## 10 Pincode

PIN CODE active: The menus of the time switch will not be accessible unless the PIN CODE has been entered. When the pin code is active, access to the button and key functions is disabled 1 minute after the last button press. PIN free access can be re-enabled by selecting PASSIVE or by resetting the device.

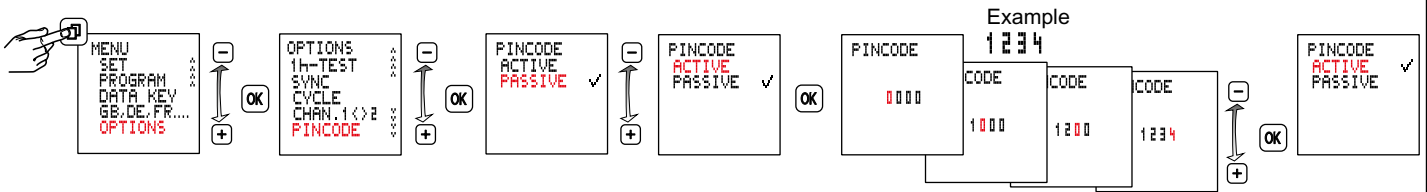

## 11 Expert mode

Some additional functions are available in Expert mode:

- Power grid synchronisation to improve the accuracy
- Cycle function
- Automatic channel switching

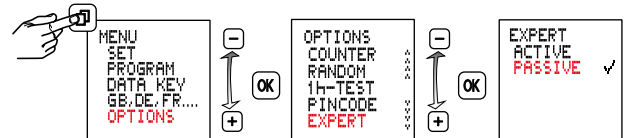

**Note:** Upon switching from ACTIVE to PASSIVE the additional menu items are hidden again and all the Expert mode settings are cancelled. After re-activating, Expert mode will operate again with the basic settings.

## 12 Holidays

After activation the holiday program is executed between 0:00h on the start date and 24:00h on the end date (Constant ON/OFF). After the holiday program has run once, it must be reactivated.

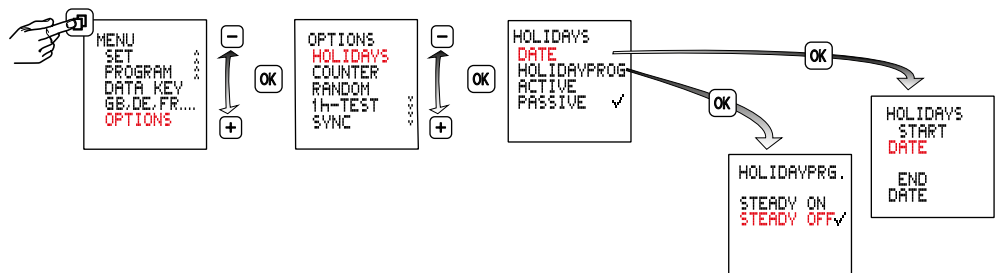

## 13 Activating and deactivating grid synchronisation

Only available in EXPERT mode

The default setting is PASSIVE. In order to improve the long-term accuracy, it is advisable to activate synchronisation if the time switch is supplied from a on 50/60 Hz grid with frequency adjustment.

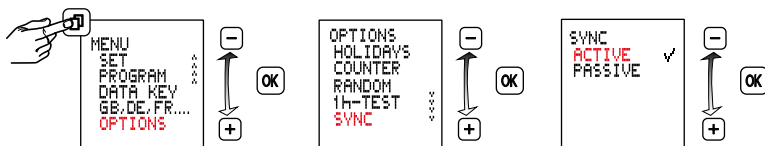

**Warning:** Electrical shock - Disconnect all power from the device before dismantling the module and replacing the battery. Always use a Li cell type battery (LiMnO<sub>2</sub>) CR2477, 3V high temperature type min +85 °C

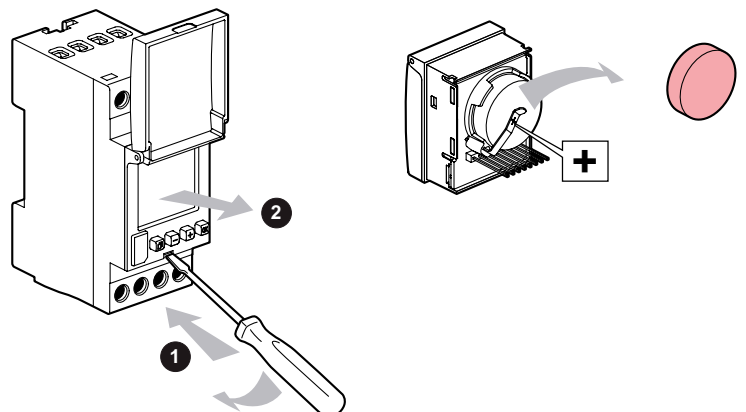

## 14 Cycle function

Only available in EXPERT mode

For cyclical switch commands the switching on time is set by logical "OR" of programs of all types. A fixed cycle of ON and OFF time then operates within those limits. The cycle always starts with the ON time.

The cycle duration and the ON time within the cycle are the same length for all switching times. The cycle duration and the ON time can be set independently in one-second increments. If the switching time is shorter than the cycle duration, the cycle will be shortened accordingly. The ON time will remain unchanged. If the switching time is actually shorter than the ON time, the ON time will be shortened accordingly.

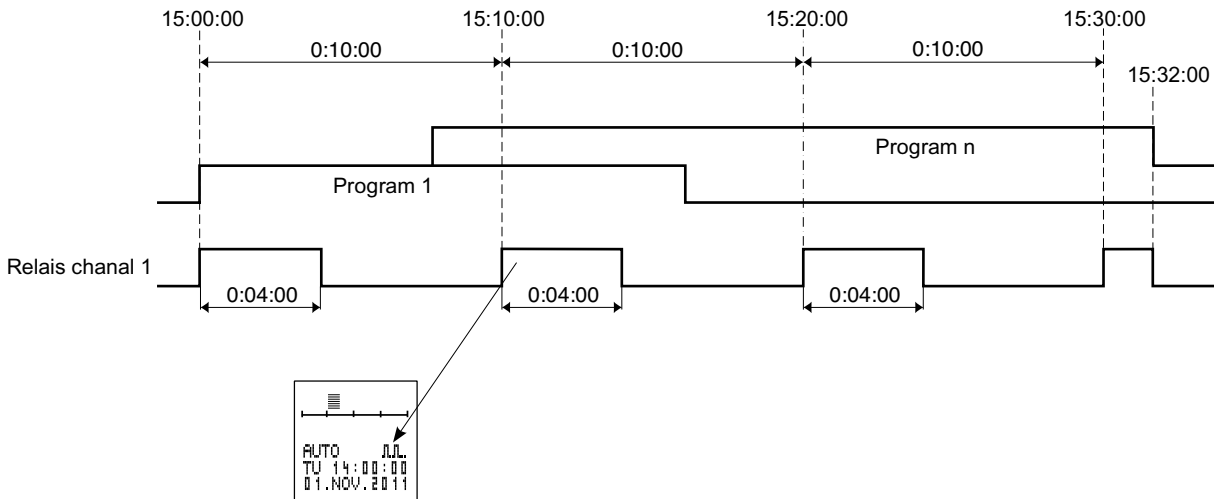
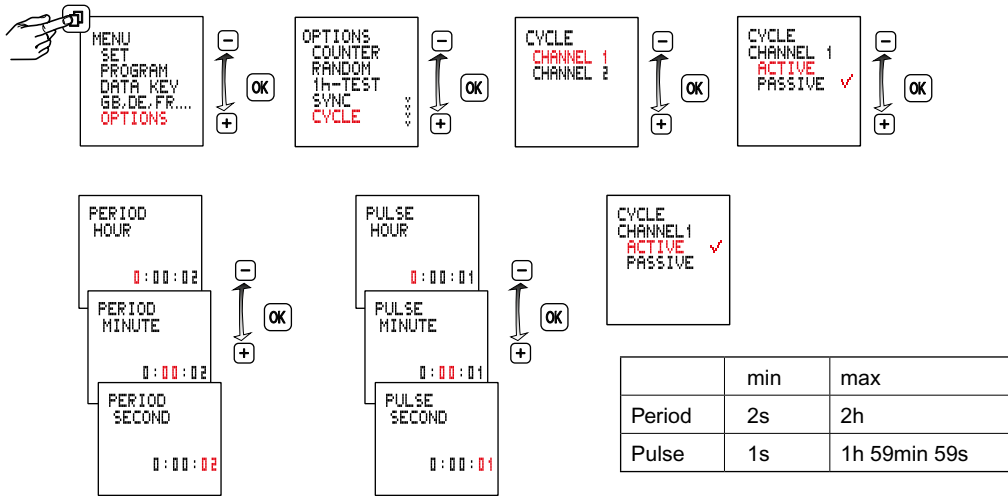

## 15 Automatic channel switching

Only available in EXPERT mode

On two-channel time switches a cyclic switch between channels can be set to conserve and/or ensure even use of connected equipment such as lamps and lights.

For example, with two sets of lights, one can be used all night long and the other for part of the night only. However, cyclical inversion of the outputs ensures that the lamps are on for the same length of time on average.

The outputs are automatically swapped over once a day (12 noon) or once a week (Sunday at 12 noon).

